

## Positioning axes DMES



- For positioning movements
- Suitable for high forces
- Low cost
- Interfaces compatible with DGE-...-SP

## Positioning axes DMES

Key features



### At a glance

#### General data

DMES positioning axes are mechanical linear drives that are specially designed for movements involving high forces.

The mechanical interfaces are compatible with the spindle axis DGE-SP.

#### Properties

- High mechanical torques
- High feed forces up to 3,000 N
- Self-retarding lead-screw spindle
- Compact dimensions
- Low cost

- Alternatively:
  - without guide
  - with plain-bearing guide GF
  - with recirculating ball bearing guide KF

#### Range of applications

- For format adjustment:
  - in printing, paper and foil wrapping machines
  - in packaging machines
  - in feed technology

### Typical applications

Adjusting sorting conveyors

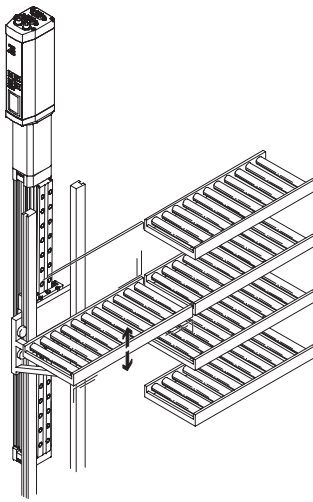

Programming formats for paper or foil cutting machines

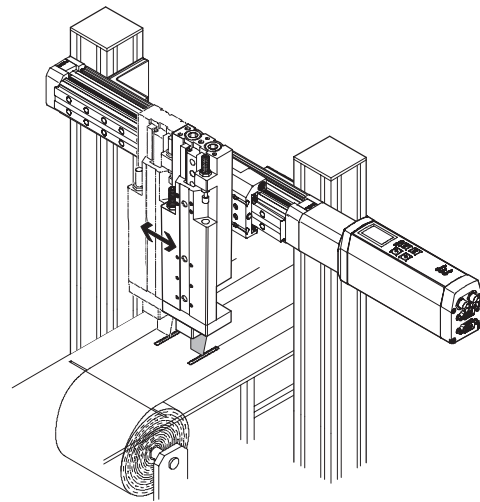

### Complete system consisting of positioning axis and motor unit

Positioning axis

→ 5 / 2.1-186

Servo-motor unit

→ 5 / 2.2-2

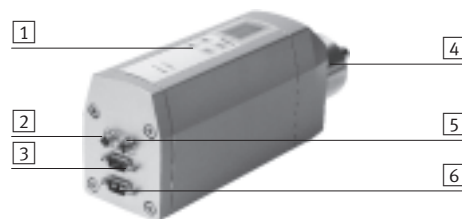
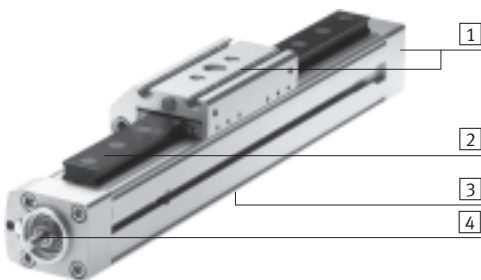

- 1 Mechanical interfaces are identical to spindle axes DGE-...-SP
- 2 Choice of two guide variants:
  - GF: Plain-bearing guide
  - KF: Recirculating ball bearing guide
- 3 Slot for proximity sensor
- 4 Lead-screw spindle, for use with high forces

**Note**  
The lead-screw spindle is self-retarding, which means that slow movements cannot be excluded in the event of vibration.  
The entire system with motor unit MTR-DCI is self-locking.

- 1 Control panel with integrated display (optional)
- 2 Input for reference switch
- 3 I/O interface
- 4 Gear unit
- 5 RS232 interface
- 6 Power supply

**Note**  
A range of specially adapted complete solutions is available for the positioning axes DMES and the servo-motor units MTR-DCI.

# Positioning axes DMES

Key features

**FESTO**

## Wide choice of variants

### Basic design DMES, without guide

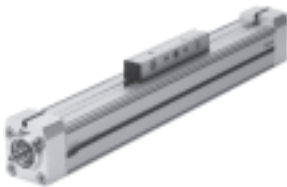

- For connection to an existing guide
- For small loads

### Plain-bearing guide DMES-GF



- With standard slide (GK) or extended slide (GV)
- For medium loads
- For medium guide precision

### Recirculating ball bearing guide DMES-KF



- With standard slide (GK) or extended slide (GV)
- For higher loads
- For high guide precision

### Protected version DMES-GA



- With standard slide (GK)
- With plain or recirculating ball bearing guide as an option
- Guide and slide are fitted with a cover to protect against the ingress of particles from above and from the side

## Guide characteristics

The specifications shown in the table are maximum values.

The precise values for each of the variants can be found in the relevant technical data in the catalogue.

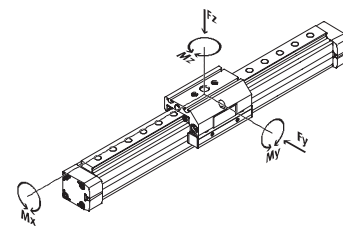
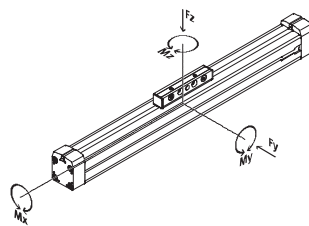

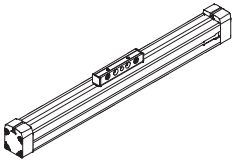
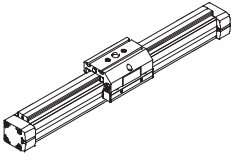
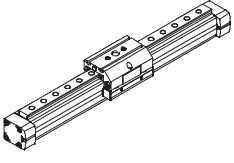
	Size	Working stroke [mm]	Speed [m/s]	Repetition accuracy [mm]	Feed force [N]	Forces and torques					→ Page
						Fy [N]	Fz [N]	Mx [Nm]	My [Nm]	Mz [Nm]	
<b>Basic design DMES</b>											
	18	50 ... 400	0.05	±0.05	240	36	80	0.4	2	0.7	5 / 2.1-188
	25	50 ... 700	0.05	±0.05	500	80	100	1.3	4	1.6	
	40	50 ... 1,200	0.05	±0.05	1,000	92	390	2.2	20	4.6	
	63	50 ... 1,800	0.05	±0.07	3,000	300	900	12	80	22	
<b>Plain-bearing guide DMES-GF</b>											
	18	50 ... 400	0.05	±0.05	240	930	930	7	45	45	5 / 2.1-202
	25	50 ... 700	0.05	±0.05	500	1,650	1,650	23	95	95	
	40	50 ... 1,200	0.05	±0.05	1,000	3,990	3,990	89	360	360	
	63	50 ... 1,800	0.05	±0.07	3,000	7,250	7,250	290	980	980	
<b>Recirculating ball bearing guide DMES-KF</b>											
	18	50 ... 400	0.05	±0.05	240	930	930	7	45	45	5 / 2.1-202
	25	50 ... 700	0.05	±0.05	500	3,080	3,080	45	170	170	
	40	50 ... 1,200	0.05	±0.05	1,000	7,300	7,300	170	660	660	
	63	50 ... 1,800	0.05	±0.07	3,000	13,900	14,050	580	1,820	1,820	

## Positioning axes DMES, without guide

Peripherals overview

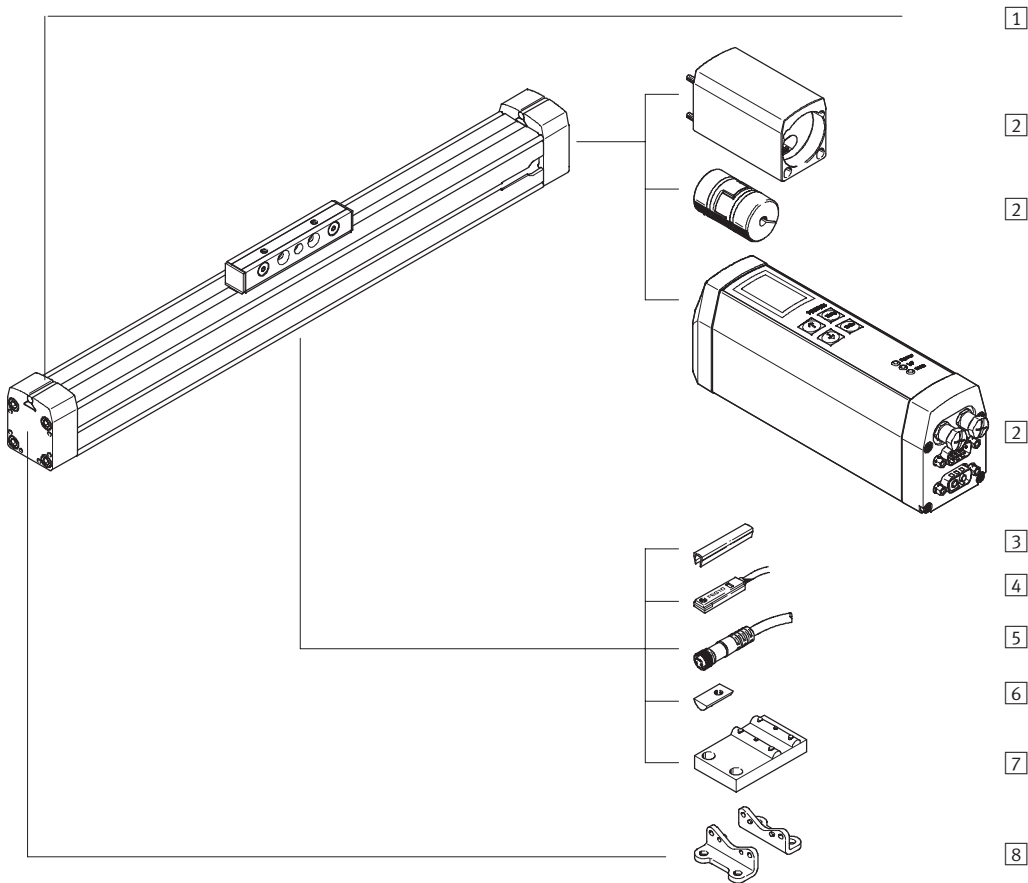

Variants and accessories		
Type/Order code	Brief description	→ Page
1 Positioning axis DMES	Electromechanical axis without guide	5 / 2.1-188
2 Servo-motor unit and axial kit AX	Complete package for axial motor attachment, comprising coupling housing, coupling and motor unit	5 / 2.1-196
3 Slot cover B/S	For protecting against ingress of dirt	5 / 2.1-224
4 Proximity sensor SMT-8	For providing a proximity signal or safety sensing	5 / 2.1-227
5 Connecting cables KM8	For proximity sensor	5 / 2.1-227
6 Slot nut for mounting slot Y	For mounting attachments	5 / 2.1-224
7 Central support M	For mounting the axis	5 / 2.1-225
8 Foot mounting F	For mounting the axis (can only be attached to end cap, must be combined with central support)	5 / 2.1-225

## Positioning axes DMES, without guide



Type codes

		DMES	-	25	-	500	-	AX	:	ZUB	-			2Y		2M		
<b>Type</b>																		
DMES	Positioning axis																	
<b>Size</b>																		
<b>Stroke [mm]</b>																		
<b>Servo-motor unit</b>																		
AX	Servo-motor unit including axial kit																	
<b>Accessories</b>																		
ZUB	Accessories supplied loose																	
<b>Slot cover</b>																		
...S	Sensor slot																	
...B	Mounting slot																	
<b>Slot nut</b>																		
...Y	For mounting slot																	
<b>Central support</b>																		
...M	Central support																	
<b>Foot mounting</b>																		
...F	Foot mounting																	

## Positioning axes DMES, without guide

Technical data

**FESTO**

-  Size  
18 ... 63
-  Stroke length  
50 ... 1,800 mm

-  [www.festo.com/en/Spare\\_parts\\_service](http://www.festo.com/en/Spare_parts_service)

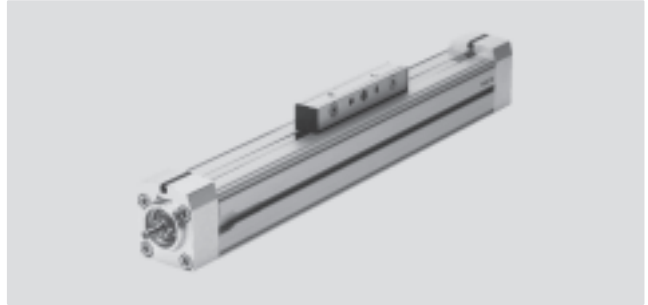

General technical data				
Size	18	25	40	63
Design	Electromechanical linear axis with lead-screw spindle			
Guide	None			
Assembly position	Any			
Working stroke [mm]	50 ... 400	50 ... 700	50 ... 1,200	50 ... 1,800
Max. feed force $F_x$ [N]	240	500	1,000	3,000
Max. driving torque [Nm]	0.3	0.9	3	14
Max. no-load driving torque <sup>1)</sup> [Nm]	0.07	0.2	0.45	1.1
Max. radial force on drive shaft [N]	40	75	250	800
Max. speed [m/s]	0.05			
Max. acceleration [m/s <sup>2</sup> ]	2.5			
Repetition accuracy [mm]	±0.05			±0.07
Positioning rigidity [N/mm]	1,700	2,300	4,200	5,600
Duty cycle [%]	100			
Reversing backlash <sup>2)</sup> [mm]	< 0.1			

- 1) Measured at a speed of 200 rpm.  
2) In new condition

Operating and environmental conditions		
Ambient temperature <sup>1)</sup> [°C]	0 ... +50	
Protection class	IP40	

- 1) Note operating range of proximity sensors

Weights [kg]				
Size	18	25	40	63
Basic weight with 0 mm stroke <sup>1)</sup>	0.49	0.98	2.9	10.05
Additional weight per 100 mm stroke	0.2	0.36	0.74	1.97
Moving load	0.06	0.15	0.47	1.51

- 1) Without coupling housing

Weights [kg] – Coupling housing									
For size	18		25		40		63		
Gear reduction ratio of MTR-DCI motor unit	G7	G14	G7	G14	G7	G14	G7	G17	G22
Coupling housing	0.085	0.085	0.30	0.33	0.97	1.06	2.65	2.65	2.65

## Positioning axes DMES, without guide

Technical data

FESTO

Mass moment of inertia					
Size		18	25	40	63
$J_0$	[kg cm <sup>2</sup> ]	0.0028	0.0147	0.1824	1.7747
$j_H$ per metre stroke	[kg cm <sup>2</sup> /m]	0.0210	0.0980	0.8400	5.5600
$j_L$ per kg working load	[kg cm <sup>2</sup> /Kg]	0.0006	0.0023	0.0041	0.0091

The mass moment of inertia  $J_A$  of the entire axis is calculated as follows:

$$J_A = J_0 + j_H \times \text{working stroke [m]} + j_L \times m_{\text{working load [kg]}}$$

Spindle					
Size		18	25	40	63
Diameter	[mm]	8	12	20	32
Pitch	[mm/rev.]	1.5	2.5	4	6

### Materials

Sectional view

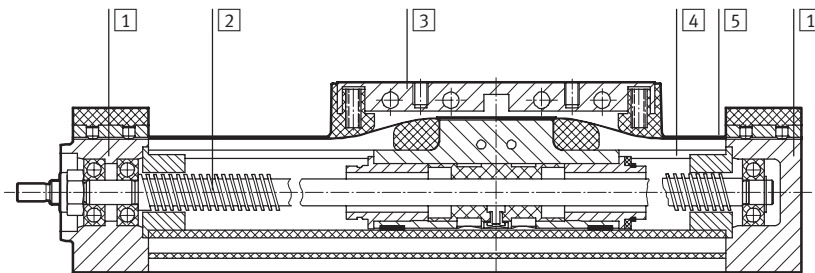

Positioning axis		
1	Cover	Wrought aluminium alloy, anodised
2	Spindle	Steel
3	Piston, driver	Wrought aluminium alloy, anodised
4	Profile	Wrought aluminium alloy, anodised
5	Cover strip	High-alloy stainless steel

## Positioning axes DMES, without guide

Technical data

### Characteristic load values

The indicated forces refer to the centre line of the internal diameter of the profile.

They must not be exceeded in the dynamic range. Special attention must be paid to the cushioning phase.

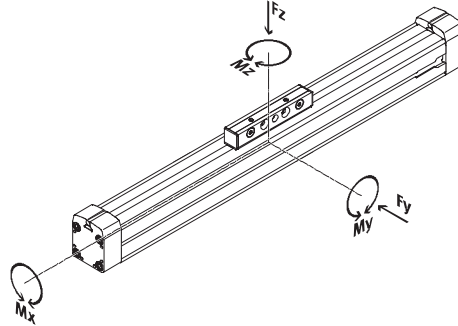

If the axis is subjected to more than two of the indicated forces simultaneously, the following equation must be satisfied in addition to the indicated maximum loads:

$$\frac{|F_y|}{F_{y\max.}} + \frac{|F_z|}{F_{z\max.}} + \frac{|M_x|}{M_{x\max.}} + \frac{|M_y|}{M_{y\max.}} + \frac{|M_z|}{M_{z\max.}} \leq 1$$

**Note**  
Positioning axes DMES without guide are not designed to absorb lateral forces or torques on the slide.

Permissible forces and torques		18	25	40	63
F <sub>y</sub> <sub>max.</sub>	[N]	36	80	92	300
F <sub>z</sub> <sub>max.</sub>	[N]	80	100	390	900
M <sub>x</sub> <sub>max.</sub>	[Nm]	0.4	1.3	2.2	12
M <sub>y</sub> <sub>max.</sub>	[Nm]	2	4	20	80
M <sub>z</sub> <sub>max.</sub>	[Nm]	0.7	1.6	4.6	22

### 2nd moment of area

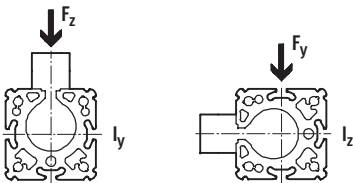

Size		18	25	40	63
ly	[cm <sup>4</sup> ]	6.90	20.92	76.24	587.74
lz	[cm <sup>4</sup> ]	6.83	21.20	71.01	464.30



PtTool  
design tool  
[www.festo.com/en/engineering](http://www.festo.com/en/engineering)





# Positioning axes DMES, without guide

Technical data

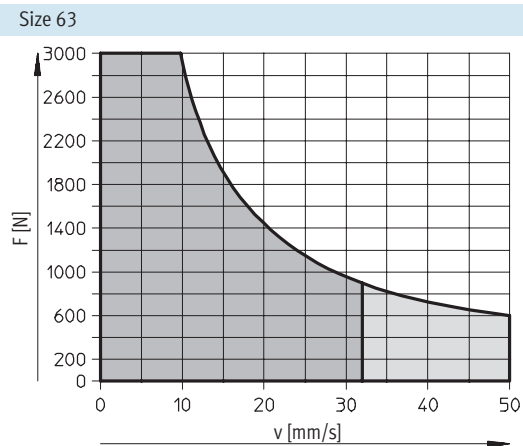
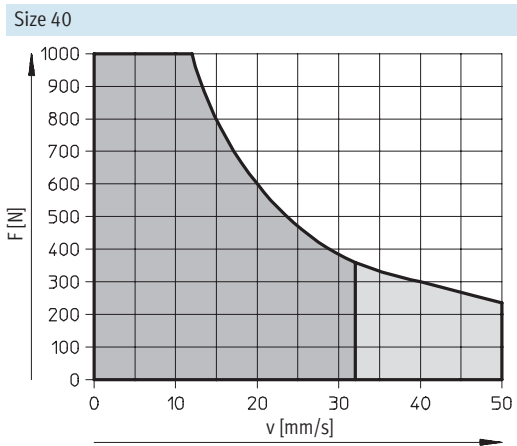
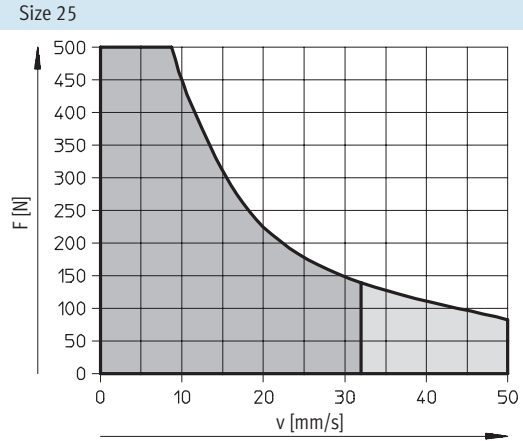
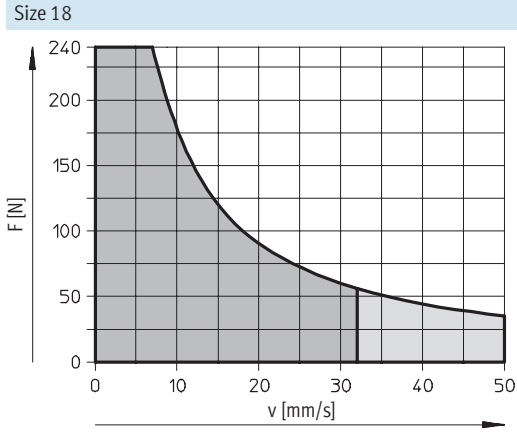
**Maximum permissible feed force F as a function of the feed speed v**



-  Recommended operating range
-  Permissible operating range (duty cycle < 50% recommended)

## Positioning axes DMES, without guide

Technical data

### Maximum permissible driving torque M as a function of n (rpm)

Size 18

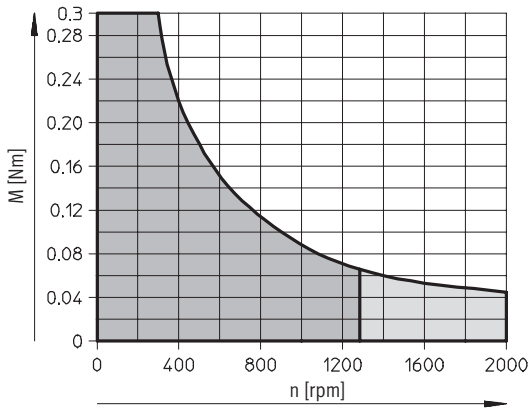

Size 25

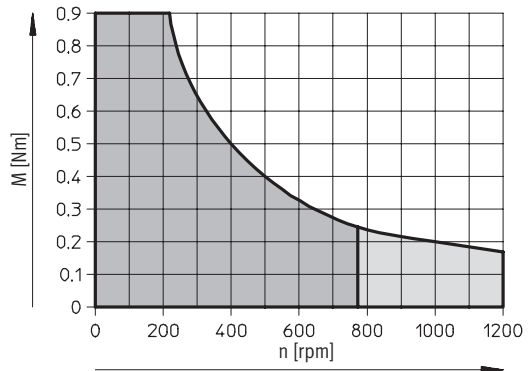

Size 40

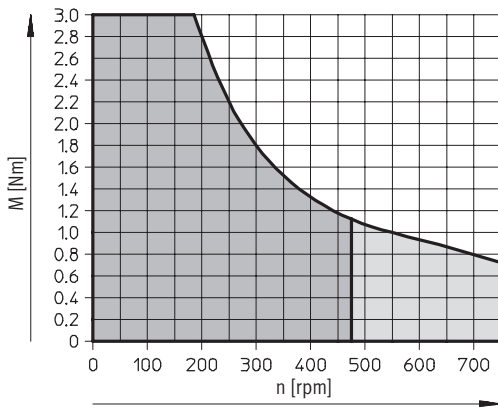

Size 63

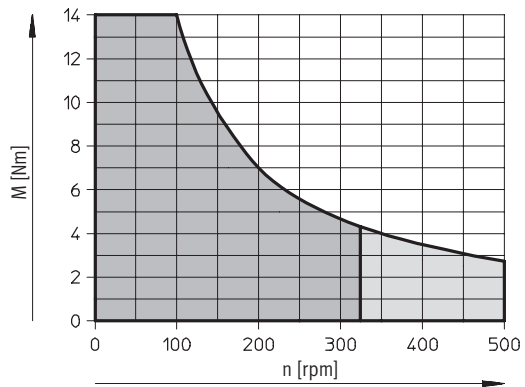

- Recommended operating range
- Permissible operating range (duty cycle < 50% recommended)

### Driving torque M as a function of the feed force F

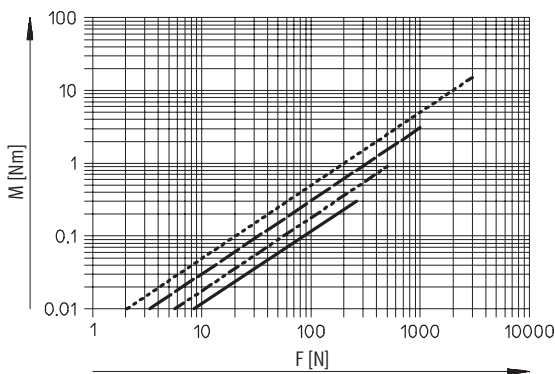

### Speed as a function of the feed speed v

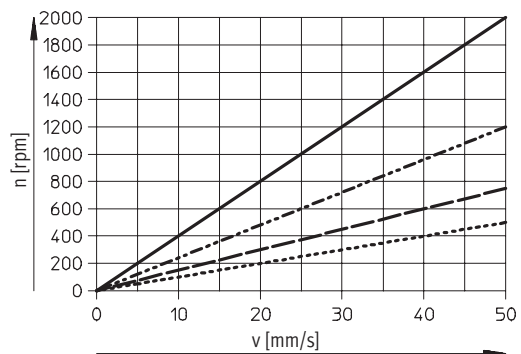

- DMES-18
- - - DMES-25
- · - DMES-40
- · · DMES-63

Positioning axes DMES, without guide

Technical data

Dimensions Download CAD data → [www.festo.com/en/engineering](http://www.festo.com/en/engineering)

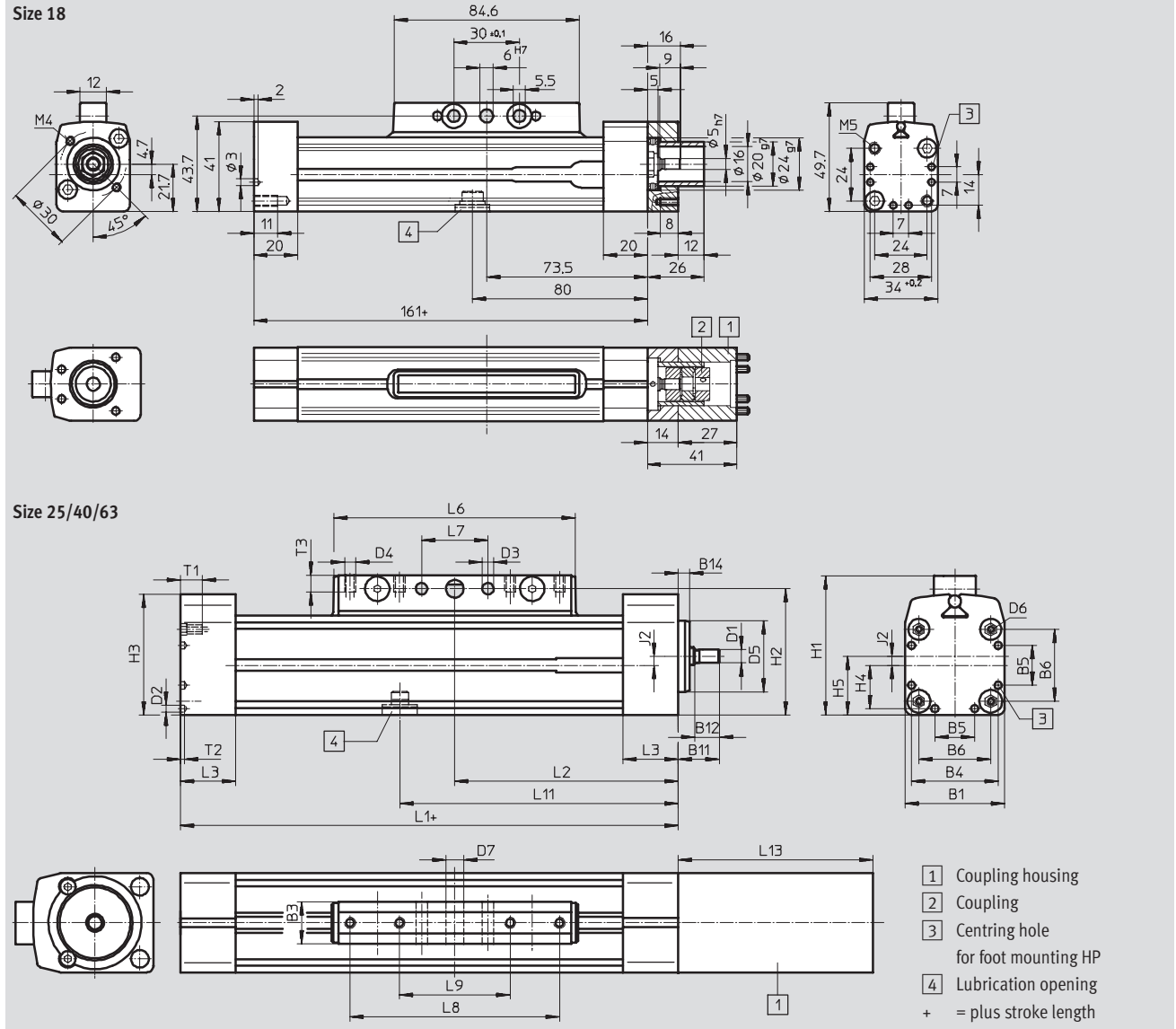

Size	B1	B3	B4	B5	B6	B11	B12	B14	D1	D2	D3	D4	D5	D6	D7	H1	H2	H3
	+0.4								∅ h7	∅	∅		∅ g7		∅ H10			
25	45	19	39.1	18	32.5	18.5	11	4	6	3.3	5.2	M5	32	M4	8	63	57	54.5
40	64	21	53	28	49	33.5	23	5	12	4.4	6.5	M6	48	M5	10	86	78	76.5
63	106	24	89	44	83	47.5	25	7	20	6.4	8.5	M8	72	M8	12	131	122	127.3

Size	H4	H5	J2	L1	L2	L3	L6	L7	L8	L9	L11	L13			T1	T2	T3
												1)	2)	3)			
								±0.1	±0.1	±0.1		1)	2)	3)			
25	19.6	26.5	4	175	87.5	25	108.8	30	–	50	105	88	101	–	13	2	7.5
40	26.5	37	5	250	126	31	170.8	70	130	40	151	121	135	–	13	6	10
63	44.5	61	8	328	164	36	233.8	110	190	70	196	150	150	150	21	6	12.5

1) When combined with motor unit MTR-DCI with gear reduction G7  
 2) When combined with motor unit MTR-DCI with gear reduction G14  
 3) When combined with motor unit MTR-DCI with gear reduction G22

## Positioning axes DMES, without guide

Technical data

**Dimensions**

Download CAD data → [www.festo.com/en/engineering](http://www.festo.com/en/engineering)

Profile

**Size 18**

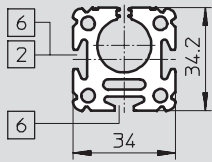

**Size 25**

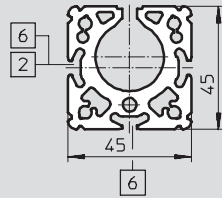

**Size 40**

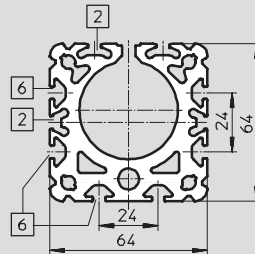

**Size 63**

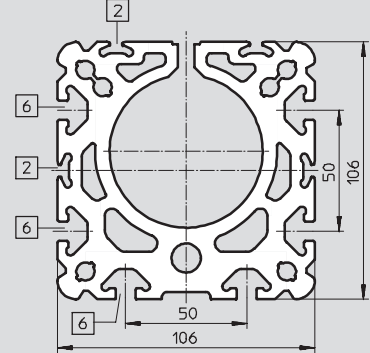

2 Sensor slot for proximity sensor

6 Mounting slot for slot nut NST



 **New**  
**Size 18/63**

## Positioning axes DMES, without guide

Ordering data – Modular products

**FESTO**

### Order code

Mandatory data

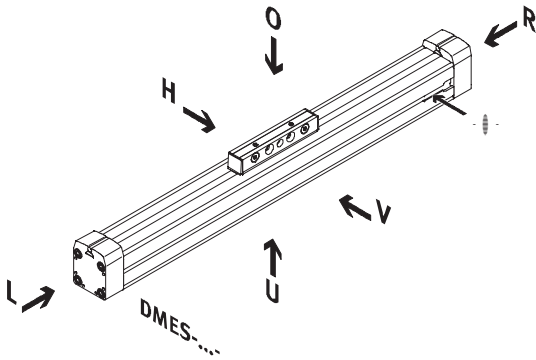

 Note

The insertion point for the proximity sensor is located on the right-hand side of the positioning axis.

O top  
 U underneath  
 V front  
 H rear  
 R right  
 L left

### Order code

Options

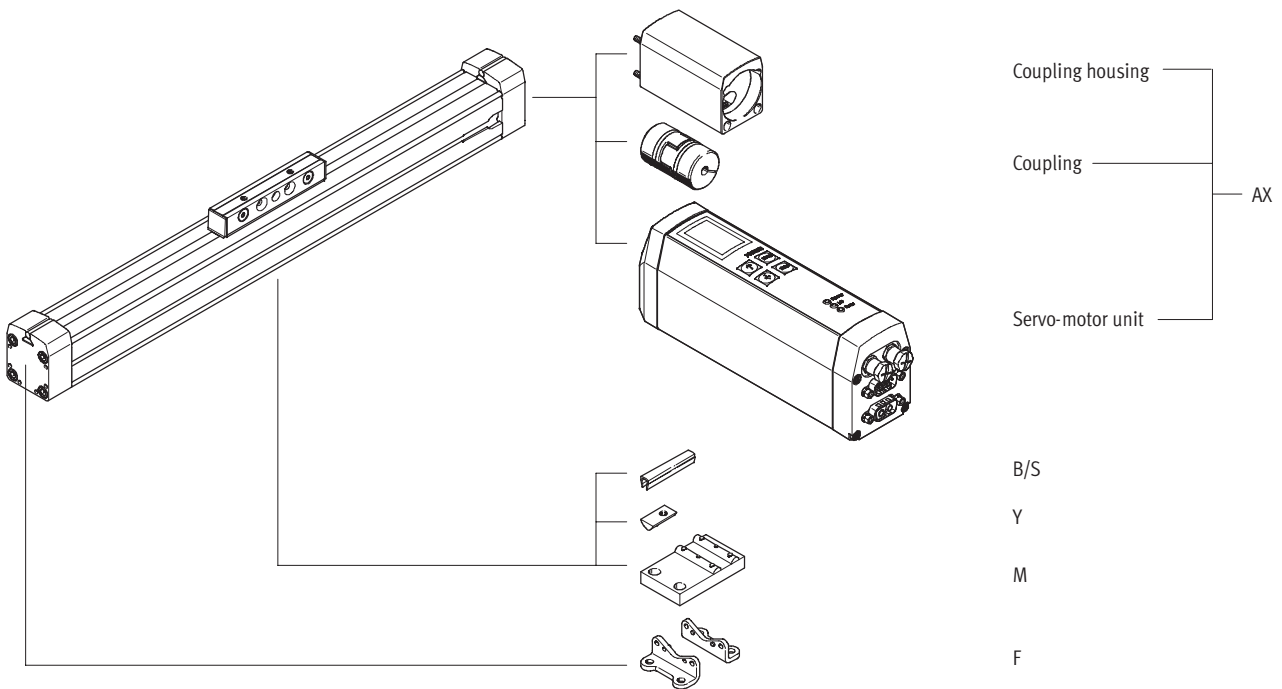

# Positioning axes DMES, without guide

Ordering data – Modular products

Mandatory data				Options		
Module No.	Function	Size	Stroke	Servo-motor unit	Accessories	Accessories supplied loose
533 699	DMES	18	50 ... 1,800	AX		...S, ...B, ...Y, ...M, ...F
533 700		25				
533 701		40				
533 702		63				
<b>Order example</b>						
533 700	DMES	- 25	- 700	:	ZUB	- 2S2Y2M

MTR-DCI-...S-...SC-E-...IO

Ordering table							
Size	18	25	40	63	Condi- tions	Code	Enter code
M Module No.	533 699	533 700	533 701	533 702			
Function	Positioning axis without guided slide					DMES	DMES
Size	18	25	40	63		-...	
Stroke [mm]	50 ... 400	50 ... 700	50 ... 1,200	50 ... 1,800		-...	
O Servo-motor unit	Axial kit for servo-motor unit (enclosed separately)				1	-AX	
Accessories	Supplied separately					:ZUB-	:ZUB-
Slot cover	Sensor slot	1 ... 10				...S	
	Mounting slot	-	-	1 ... 10		...B	
Slot nut	Mounting slot	1 ... 10				...Y	
Central support		1 ... 10				...M	
Foot mounting		1 ... 10				...F	

1 AX Order processing for motor unit MTR-DCI → 5 / 2.2-9

Transfer order code

	DMES	-		-		:	ZUB	-	
MTR-DCI-...S-...SC-E-...IO									

**Positioning axes DMES-GF/-KF, with guide**

Peripherals overview

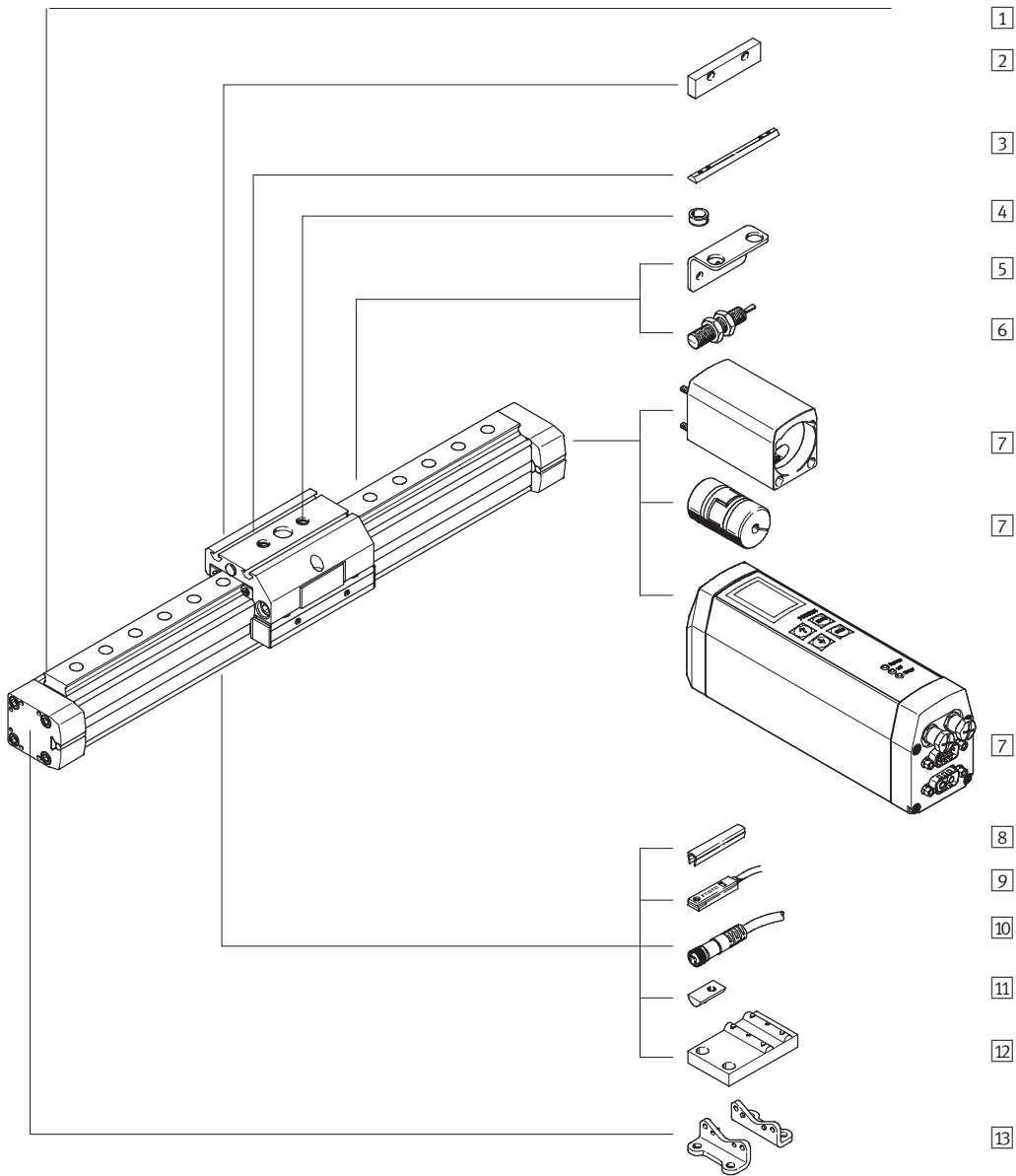



## Positioning axes DMES-GF/-KF, with guide

Peripherals overview

**FESTO**

Variants and accessories					
Type/Order code	Brief description	GK/GV	GA	→ Page	
1	Positioning axis DMES	Electromechanical axis with spindle and plain-bearing guide or recirculating ball bearing guide	■	■	5 / 2.1-202
2	Switching lug L	For sensing the slide position with inductive proximity sensors	■	-	5 / 2.1-226
3	Slot nut for slide X	For mounting loads and attachments on the slide	■	■	5 / 2.1-224
4	Centring sleeves Z	For centring loads and attachments on the slide	■	■	5 / 2.1-224
5	Sensor retainer T	Adapter for mounting the inductive proximity sensors on the axis	■	-	5 / 2.1-226
6	Inductive proximity sensor SIEN	For providing a proximity signal or safety sensing	■	-	5 / 2.1-227
7	Servo-motor unit and axial kit AX	Complete package for axial motor attachment, comprising coupling housing, coupling and motor unit	■	■	5 / 2.1-221
8	Slot cover B/S	For protecting against ingress of dirt	■	■	5 / 2.1-224
9	Proximity sensor SMT-8	For providing a proximity signal or safety sensing	■	■	5 / 2.1-227
10	Connecting cables KM8	For proximity sensor	■	■	5 / 2.1-227
11	Slot nut for mounting slot Y	For mounting attachments	■	■	5 / 2.1-224
12	Central support M	For mounting the axis	■	■	5 / 2.1-225
13	Foot mounting F	For mounting the axis (can only be attached to end cap, must be combined with central support)	■	■	5 / 2.1-225

GK: Standard slide  
GV: Extended slide  
GA: Protected version

**Positioning axes DMES-GF/-KF, with guide**

Type codes

		DMES	-	25	-	500	-	KF	-	GK	-	SH	-		-	AX
<b>Type</b>																
DMES	Positioning axis															
<b>Size</b>																
<b>Stroke [mm]</b>																
<b>Guide</b>																
GF	Plain-bearing guide															
KF	Recirculating ball bearing guide															
<b>Guided slide</b>																
GK	Standard slide															
GV	Extended slide															
GA	Protected version															
<b>Slide attachment position</b>																
SV	Front															
SH	Rear															
<b>Additional slide</b>																
KL	Left															
KR	Right															
<b>Motor unit</b>																
AX	Servo-motor unit including axial kit															

## Positioning axes DMES-GF/-KF, with guide



Type codes

		: ZUB		2X	2M		Z	2T	L
<b>Accessories</b>									
ZUB	Accessories supplied loose								
<b>Slot cover</b>									
...S	Sensor slot								
...B	Mounting slot								
<b>Slot nut</b>									
...Y	For mounting slot								
...X	For slide								
<b>Central support</b>									
...M	Central support								
<b>Foot mounting</b>									
...F	Foot mounting								
<b>Centring sleeve</b>									
...Z	For slide								
<b>Mounting bracket</b>									
...T	For inductive proximity sensors								
<b>Switching lug</b>									
L	Switching lug								

## Positioning axes DMES-GF/-KF, with guide

Technical data

**FESTO**

-  Size  
18 ... 63
-  Stroke length  
50 ... 1,800 mm

-  [www.festo.com/en/  
Spare\\_parts\\_service](http://www.festo.com/en/Spare_parts_service)

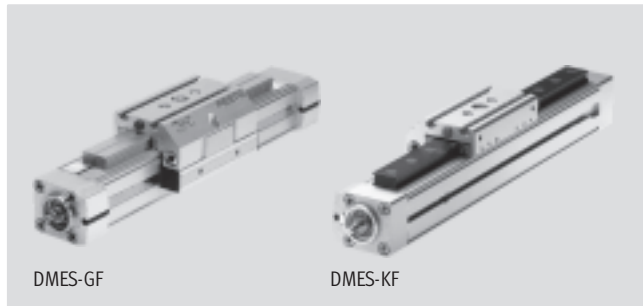

General technical data				
Size	18	25	40	63
Design	Electromechanical linear axis with lead-screw spindle			
Guide	With plain-bearing guide or recirculating ball bearing guide			
Assembly position	Any			
Working stroke [mm]	50 ... 400	50 ... 700	50 ... 1,200	50 ... 1,800
Max. feed force $F_x$ [N]	240	500	1,000	3,000
Max. driving torque [Nm]	0.3	0.9	3	14
Max. no-load driving torque <sup>1)</sup> [Nm]	0.07	0.2	0.45	1.1
Max. radial force on drive shaft [N]	40	75	250	800
Max. speed [m/s]	0.05			
Max. acceleration [m/s <sup>2</sup> ]	2.5			
Repetition accuracy [mm]	±0.05			±0.07
Positioning rigidity [N/mm]	1,700	2,300	4,200	5,600
Duty cycle [%]	100			
Reversing backlash <sup>2)</sup> [mm]	< 0.1			

- 1) Measured at a speed of 200 rpm.  
2) In new condition

Operating and environmental conditions		
Ambient temperature <sup>1)</sup> [°C]	0 ... +50	
Protection class	IP40	

- 1) Note operating range of proximity sensors

Weights [kg]									
Size		18		25		40		63	
Guide type		GF	KF	GF	KF	GF	KF	GF	KF
Basic weight with 0 mm stroke <sup>1)</sup>	GK	0.77	0.93	1.52	1.70	4.11	5.06	13.31	16.48
	GV	1.16	1.37	2.34	2.61	6.53	8.06	21.75	27.14
	GA	1.49	1.65	2.73	2.90	7.15	8.14	–	–
Additional weight per 100 mm stroke	GK	0.238	0.294	0.466	0.547	0.841	1.170	2.079	2.958
	GV	0.238	0.294	0.466	0.547	0.841	1.170	2.079	2.958
	GA	0.313	0.369	0.556	0.638	0.965	1.294	–	–
Moving load	GK	0.29	0.38	0.55	0.66	1.49	1.83	4.48	5.29
	GV	0.48	0.56	0.88	0.99	2.38	2.72	7.06	7.88
	GA	0.71	0.81	1.19	1.30	2.90	3.24	–	–
Additional slide	KL/KR	–	0.29	–	0.440	–	1.21	–	3.55

- 1) Without coupling housing

## Positioning axes DMES-GF/-KF, with guide

Technical data

FESTO

Weights [kg] – Coupling housing									
For size	18		25		40		63		
Gear reduction ratio of MTR-DCI motor unit	G7	G14	G7	G14	G7	G14	G7	G17	G22
Coupling housing	0.085		0.30	0.33	0.97	1.06	2.65		

Mass moment of inertia										
Size	18		25		40		63			
Guide type	GF	KF	GF	KF	GF	KF	GF	KF		
$J_0$	GK [kg cm <sup>2</sup> ]	0.0030	0.0030	0.0156	0.0158	0.1865	0.1879	1.8018	1.8093	
	GV [kg cm <sup>2</sup> ]	0.0048	0.0049	0.0263	0.0265	0.3327	0.3340	3.2184	3.2258	
	GA [kg cm <sup>2</sup> ]	0.0038	0.0039	0.0209	0.0212	0.2463	0.2476	–	–	
$j_H$ per metre stroke	[kg cm <sup>2</sup> /m]	0.0210	0.0210	0.0980	0.0980	0.8400	0.8400	5.5600	5.5600	
$j_L$ per kg working load	[kg cm <sup>2</sup> /Kg]	0.0006	0.0006	0.0023	0.0023	0.0041	0.0041	0.0091	0.0091	
$j_W$ for additional slide	[kg cm <sup>2</sup> ]	–	0.0002	–	0.0010	–	0.0049	–	0.0324	

The mass moment of inertia  $J_A$  of the entire axis is calculated as follows:

$$J_A = J_0 + j_H \times \text{working stroke [m]} + j_L \times m_{\text{working load [kg]}} + i \times j_W$$

$i$  = Number of additional slides

Spindle					
Size		18	25	40	63
Diameter	[mm]	8	12	20	32
Pitch	[mm/rev.]	1.5	2.5	4	6

### Materials

Sectional view

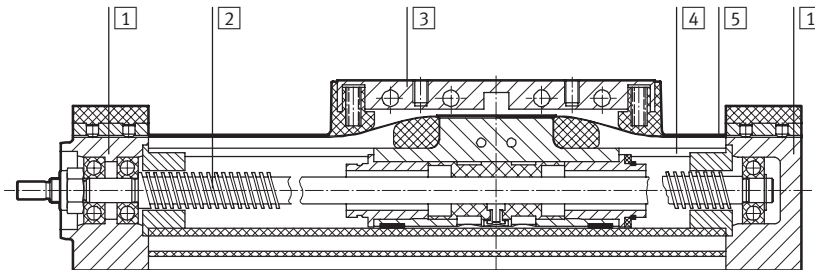

Positioning axis	
1	Cover Wrought aluminium alloy, anodised
2	Spindle Steel
3	Piston, driver Wrought aluminium alloy, anodised
4	Profile Wrought aluminium alloy, anodised
5	Cover strip High-alloy stainless steel
–	Guide rail for GF Anodised aluminium
–	Guide rail for KF Hardened steel

## Positioning axes DMES-GF/-KF, with guide

Technical data



### Characteristic load values for axis with standard slide GK or protected version GA

The indicated forces and torques refer to the centre of the guide rail. They must not be exceeded in the dynamic range. Special attention must be paid to the cushioning phase.

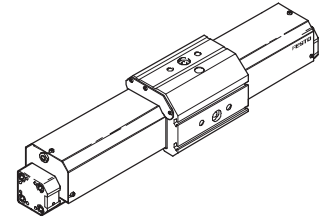
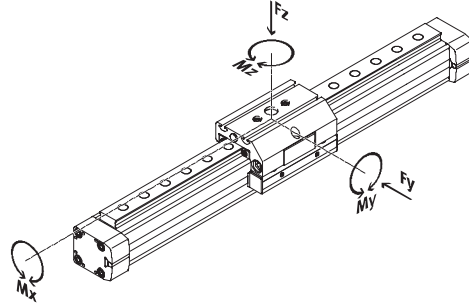

If the axis is subjected to more than two of the indicated forces and torques simultaneously, the following equation must be satisfied in addition to the indicated maximum loads:

$$\frac{|F_y|}{F_{y_{max}}} + \frac{|F_z|}{F_{z_{max}}} + \frac{|M_x|}{M_{x_{max}}} + \frac{|M_y|}{M_{y_{max}}} + \frac{|M_z|}{M_{z_{max}}} \leq 1$$

Permissible forces and torques									
Size		18		25		40		63	
Guide type		GF	KF	GF	KF	GF	KF	GF	KF
F <sub>y</sub> <sub>max.</sub>	[N]	930	930	1,760	2,600	3,070	4,300	3,880	6,600
F <sub>z</sub> <sub>max.</sub>	[N]	930	930	1,760	2,600	4,300	4,300	6,600	6,600
M <sub>x</sub> <sub>max.</sub>	[Nm]	7	7	24	45	98	160	220	400
M <sub>y</sub>	[Nm]	23	23	52	85	210	330	580	910
M <sub>z</sub> <sub>max.</sub>	[Nm]	23	23	52	85	210	330	580	910

### 2nd moment of area

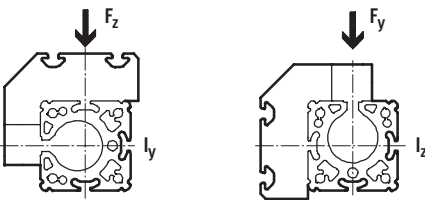

Size		18		25		40		63	
Guide type		GF	KF	GF	KF	GF	KF	GF	KF
I <sub>y</sub>	[cm <sup>4</sup> ]	11.19	14.37	39.10	47.60	125.38	176.24	709.04	992.06
I <sub>z</sub>	[cm <sup>4</sup> ]	7.11	7.16	25.85	23.34	84.76	95.43	614.44	693.35



PtTool  
design tool  
[www.festo.com/en/engineering](http://www.festo.com/en/engineering)

## Positioning axes DMES-GF/-KF, with guide

Technical data

### Characteristic load values for axis with extended slide GV

The indicated forces and torques refer to the centre of the guide rail. They must not be exceeded in the dynamic range. Special attention must be paid to the cushioning phase.

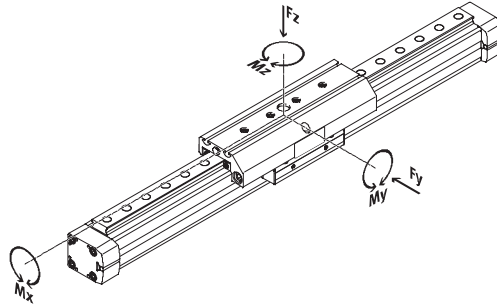

If the axis is subjected to more than two of the indicated forces and torques simultaneously, the following equation must be satisfied in addition to the indicated maximum loads:

$$\frac{|F_{y1}|}{F_{y_{max}}} + \frac{|F_{z1}|}{F_{z_{max}}} + \frac{|M_{x1}|}{M_{x_{max}}} + \frac{|M_{y1}|}{M_{y_{max}}} + \frac{|M_{z1}|}{M_{z_{max}}} \leq 1$$

### Permissible forces and torques

Size	18		25		40		63	
Guide type	GF	KF	GF	KF	GF	KF	GF	KF
F <sub>y</sub> <sub>max.</sub> [N]	930	930	1,650	3,080	3,990	7,300	7,250	13,900
F <sub>z</sub> <sub>max.</sub> [N]	930	930	1,650	3,080	3,990	7,300	7,250	14,050
M <sub>x</sub> <sub>max.</sub> [Nm]	7	7	23	45	89	170	290	580
M <sub>y</sub> [Nm]	45	45	95	170	360	660	980	1,820
M <sub>z</sub> <sub>max.</sub> [Nm]	45	45	95	170	360	660	980	1,820

### 2nd moment of area

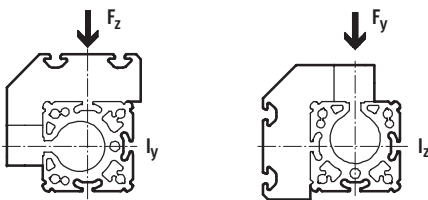

Size	18		25		40		63	
Guide type	GF	KF	GF	KF	GF	KF	GF	KF
I <sub>y</sub> [cm <sup>4</sup> ]	11.19	14.37	39.10	47.60	125.38	176.24	709.04	992.06
I <sub>z</sub> [cm <sup>4</sup> ]	7.11	7.16	25.85	23.34	84.76	95.43	614.44	693.35

## Positioning axes DMES-GF/-KF, with guide

Technical data

### Deflection of the positioning axis as a function of the working load $F$ and the support span $l$

The following diagrams can be used to determine the deflection of a positioning axis supported externally at

both ends (see drawing below). A differentiation is made between two load directions. The axis may also

need to be supported with central supports MUP in order to limit deflection in the case of large strokes.

#### Deflection along the y-axis

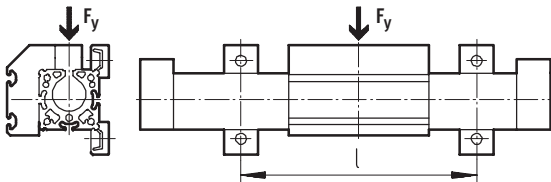

#### Deflection along the z-axis

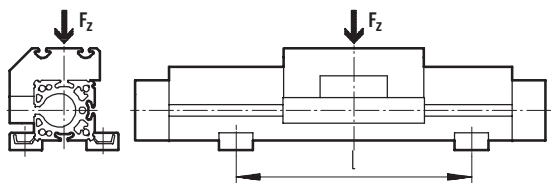

#### Example showing how to determine deflection

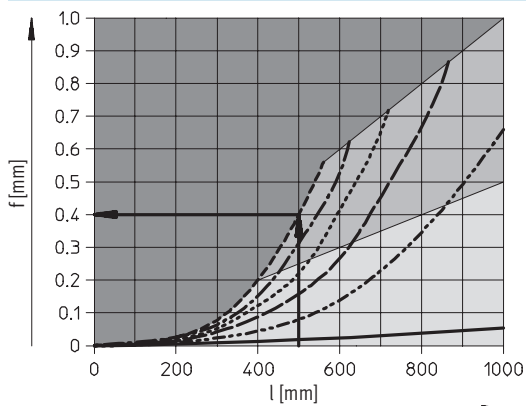

----- 2,500 N

- Impermissible range: The positioning axis may not be used.
- Static range: The slide may not be moved under load.
- Static and dynamic range: The slide may be moved under load.

#### Given:

Positioning axis  
DMES-25-700-KF...

Working stroke = 700 mm

Total length of the positioning axis,  
dimensional drawing  $\rightarrow$  5 / 2.1-213  
700 mm + 175 mm = 875 mm

Working load  $F$  = 2,500 N

Support span  $l$  = 500 mm

#### To be found:

Deflection  $f$

#### Procedure:

A support span of 500 mm (see X-axis) and a working load of 2,500 N (see characteristic curve) produces a deflection of 0.4 mm.

#### Note:

The slide may not be moved under this load as the operating point is in the static area of the diagram. In order to be able to operate the slide dynamically, the support span must be reduced to 400 mm.



# Positioning axes DMES-GF/-KF, with guide

Technical data



**Deflection of the positioning axis as a function of the working load  $F$  and the working stroke  $l$**

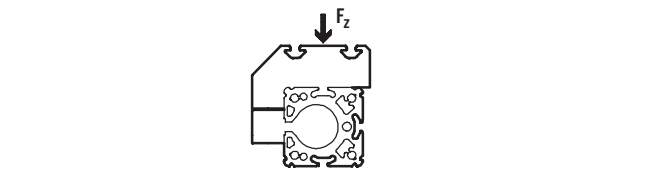
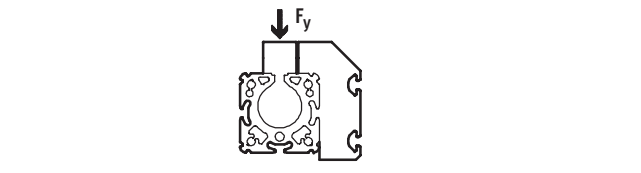

DMES-18-GF, with plain-bearing guide

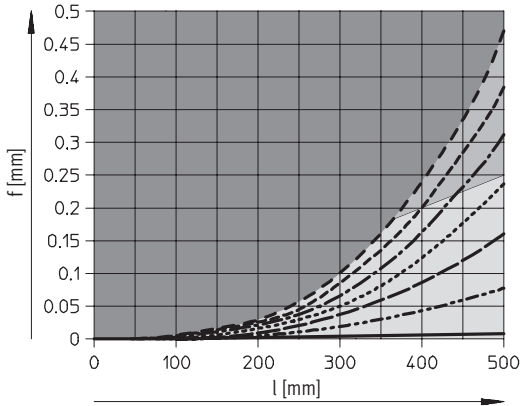

—	0 N	- - - - -	600 N
- · - · - ·	150 N	- - - - -	750 N
- - - - -	300 N	- - - - -	900 N
- · - · - ·	450 N		

DMES-18-GF, with plain-bearing guide

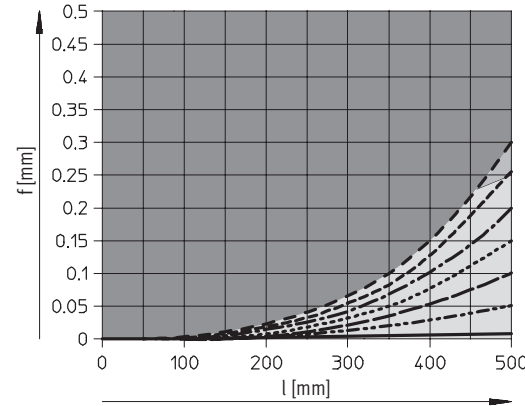

—	0 N	- - - - -	600 N
- · - · - ·	150 N	- - - - -	750 N
- - - - -	300 N	- - - - -	900 N
- · - · - ·	450 N		

DMES-18-KF, with recirculating ball bearing guide

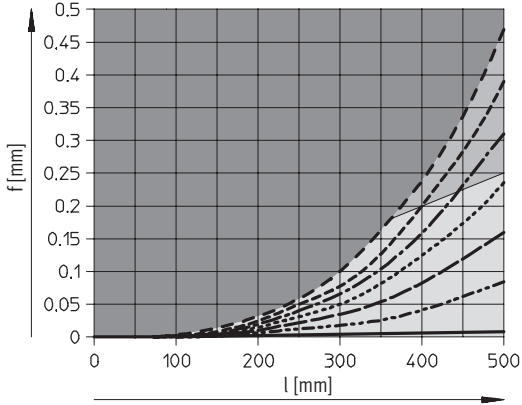

—	0 N	- - - - -	600 N
- · - · - ·	150 N	- - - - -	750 N
- - - - -	300 N	- - - - -	900 N
- · - · - ·	450 N		

DMES-18-KF, with recirculating ball bearing guide

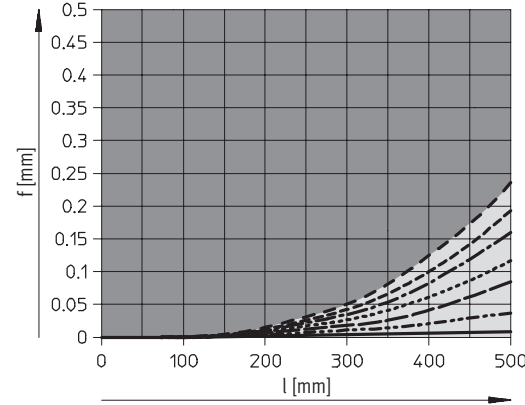

—	0 N	- - - - -	600 N
- · - · - ·	150 N	- - - - -	750 N
- - - - -	300 N	- - - - -	900 N
- · - · - ·	450 N		

Impermissible range  
 Static range  
 Static and dynamic range

# Positioning axes DMES-GF/-KF, with guide

Technical data



## Deflection of the positioning axis as a function of the working load $F$ and the working stroke $l$

Along the y-axis

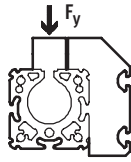

Along the z-axis

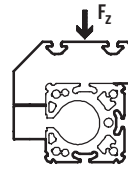

DMES-25-GF, with plain-bearing guide

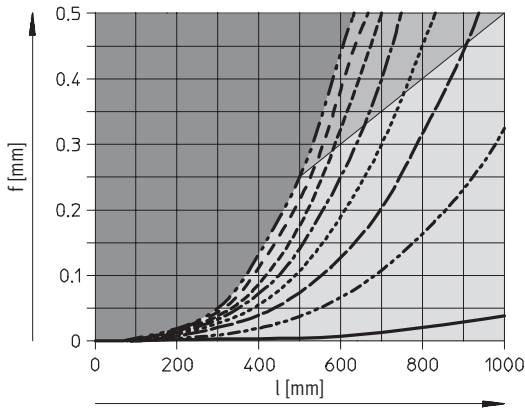

DMES-25-GF, with plain-bearing guide

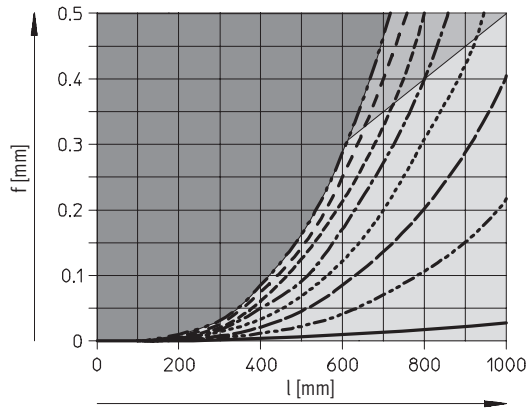

DMES-25-KF, with recirculating ball bearing guide

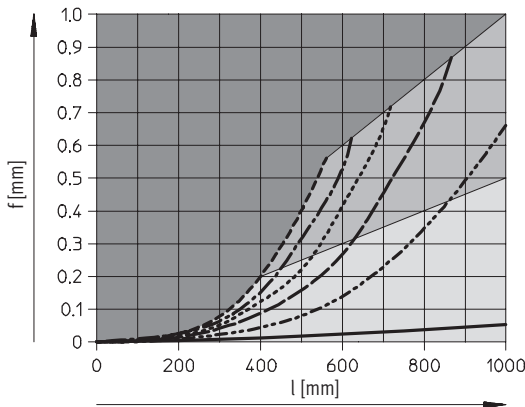

DMES-25-KF, with recirculating ball bearing guide

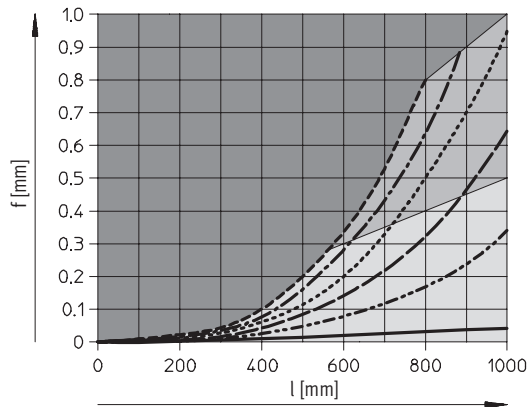

- Impermissible range
- Static range
- Static and dynamic range

# Positioning axes DMES-GF/-KF, with guide

Technical data

FESTO

## Deflection of the positioning axis as a function of the working load $F$ and the working stroke $l$

Along the y-axis

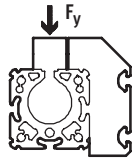

Along the z-axis

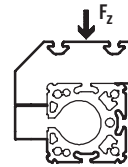

### DMES-40-GF, with plain-bearing guide

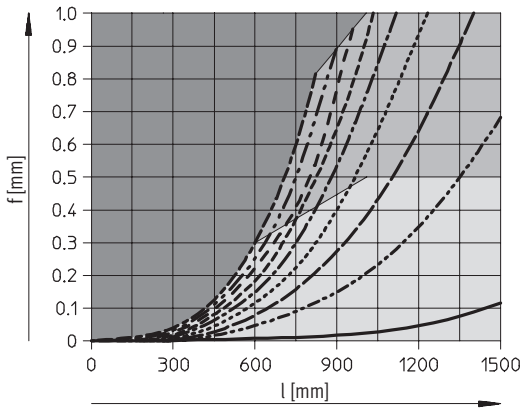

### DMES-40-GF, with plain-bearing guide

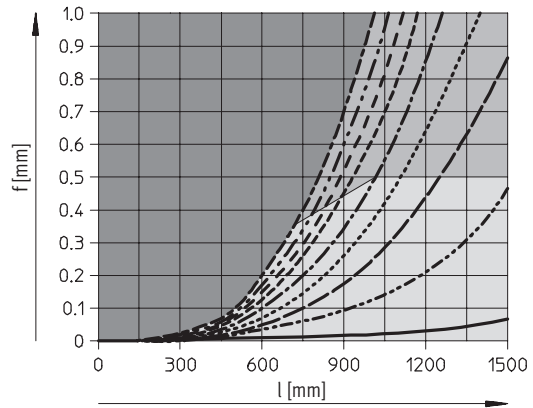

### DMES-40-KF, with recirculating ball bearing guide

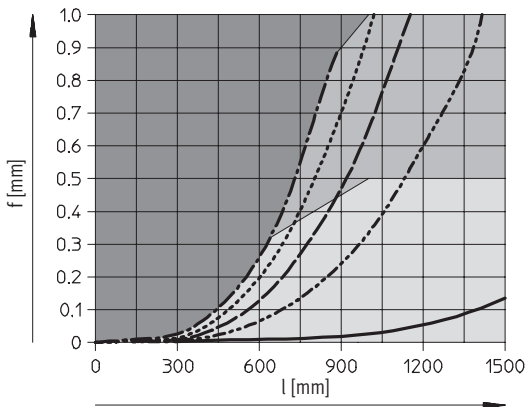

### DMES-40-KF, with recirculating ball bearing guide

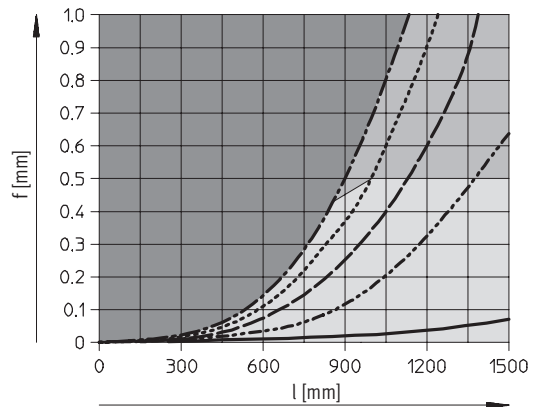

- Impermissible range
- Static range
- Static and dynamic range

# Positioning axes DMES-GF/-KF, with guide

Technical data



## Deflection of the positioning axis as a function of the working load $F$ and the working stroke $l$

Along the y-axis

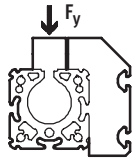

Along the z-axis

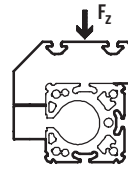

DMES-63-GF, with plain-bearing guide

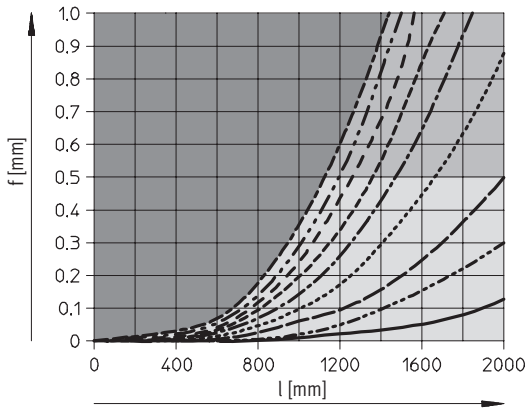

DMES-63-GF, with plain-bearing guide

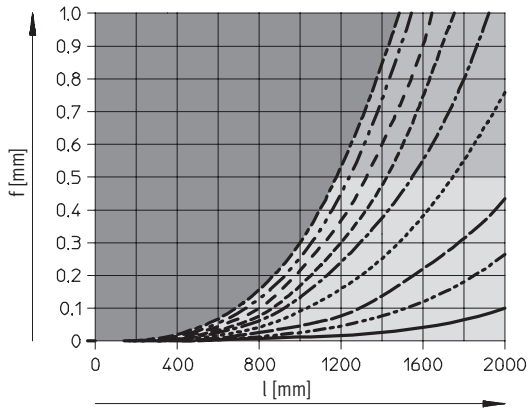

DMES-63-KF, with recirculating ball bearing guide

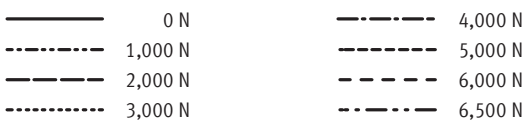
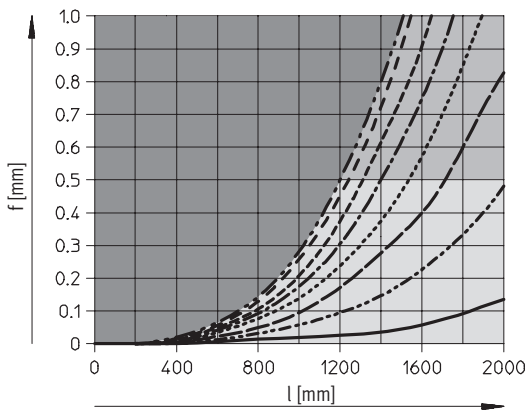

DMES-63-KF, with recirculating ball bearing guide

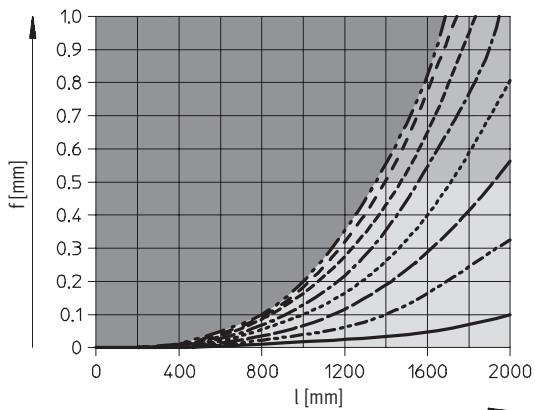

- Impermissible range
- Static range
- Static and dynamic range

# Positioning axes DMES-GF/-KF, with guide

Technical data

## Maximum permissible feed force F as a function of the feed speed v

Size 18

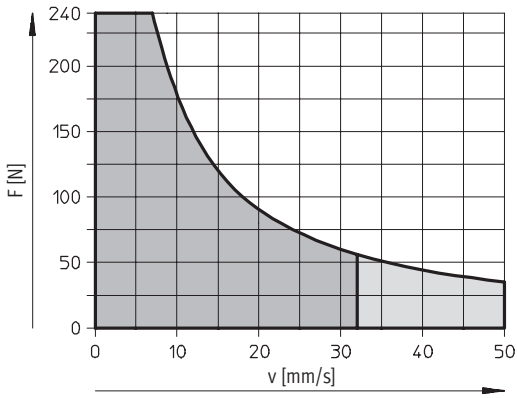

Size 25

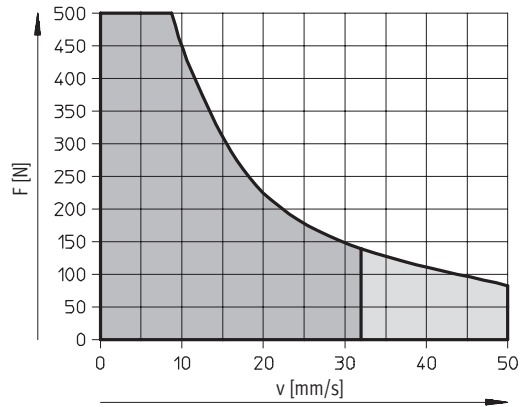

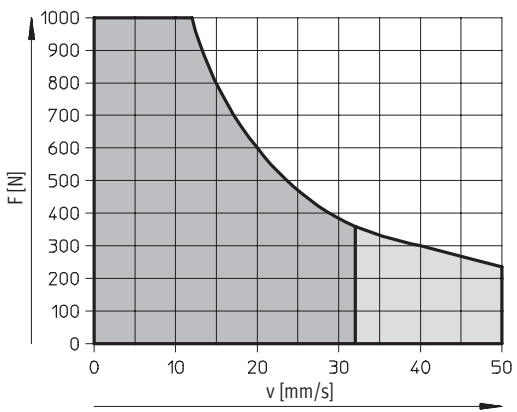

Size 40

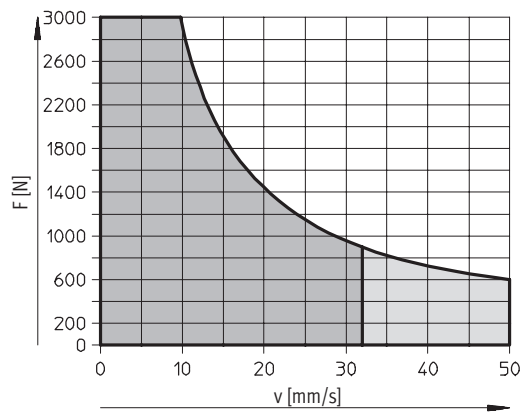

Size 63



-  Recommended operating range
-  Permissible operating range (duty cycle < 50% recommended)

# Positioning axes DMES-GF/-KF, with guide

Technical data



## Maximum permissible driving torque M as a function of n (rpm)

Size 18

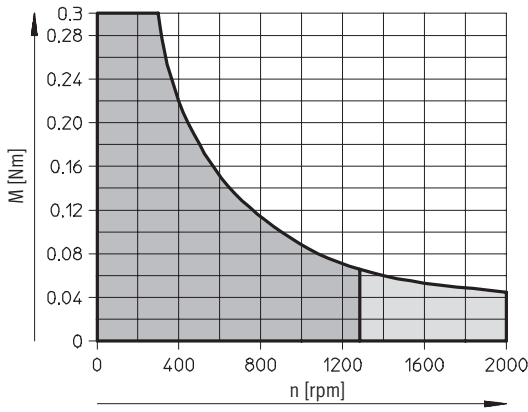

Size 25

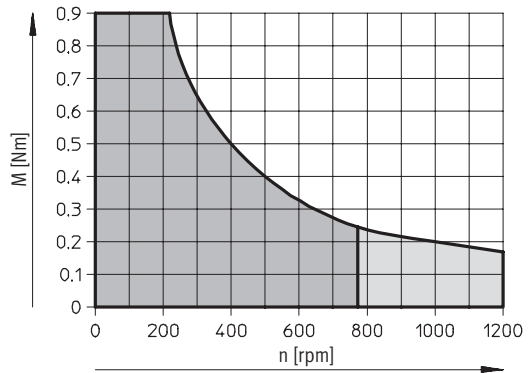

Size 40

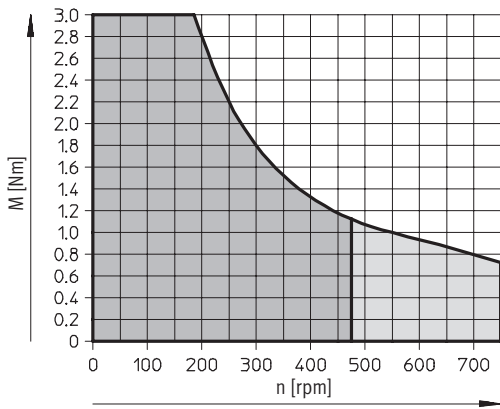

Size 63

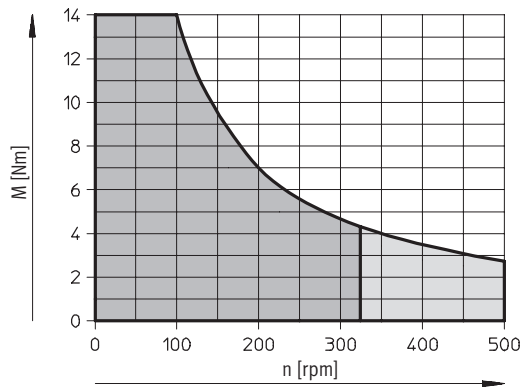

- Recommended operating range
- Permissible operating range (duty cycle < 50% recommended)

## Driving torque M as a function of the feed force F

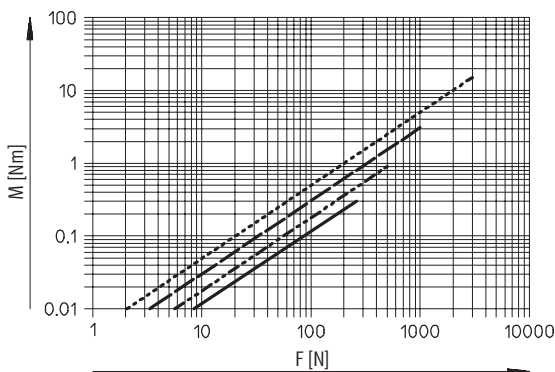

## Speed as a function of the feed speed v

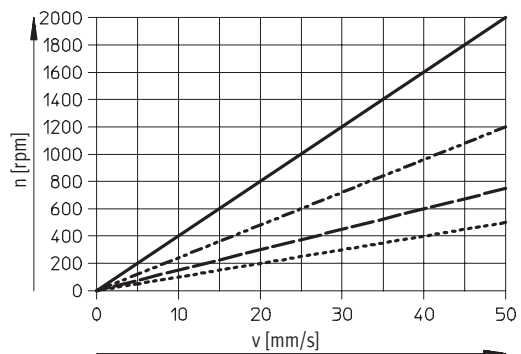

- DMES-18
- - - DMES-25
- · - DMES-40
- · · DMES-63

## Positioning axes DMES-GF/-KF, with guide

Technical data

**FESTO**

**Dimensions** Download CAD data → [www.festo.com/en/engineering](http://www.festo.com/en/engineering)

Standard slide GK  
**Size 18**

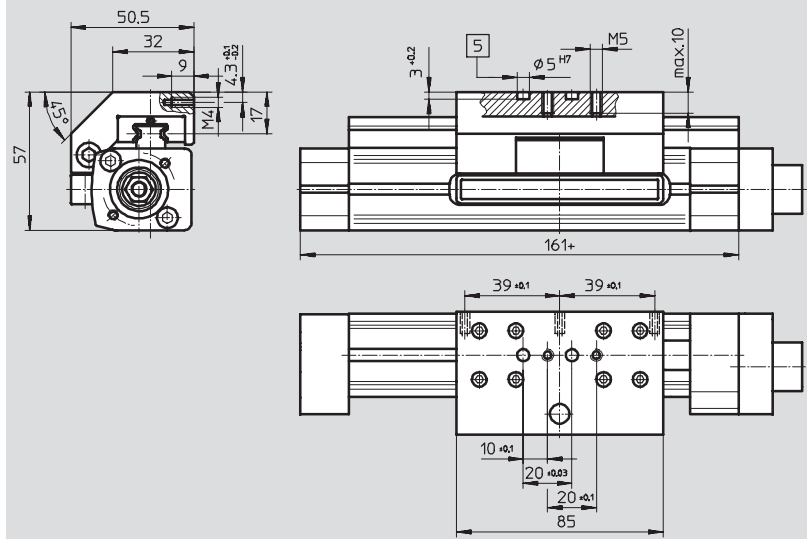

- 5 Hole for centring pin ZBS-5

Basic dimensions  
→ 5 / 2.1-193

**Size 25/40/63**

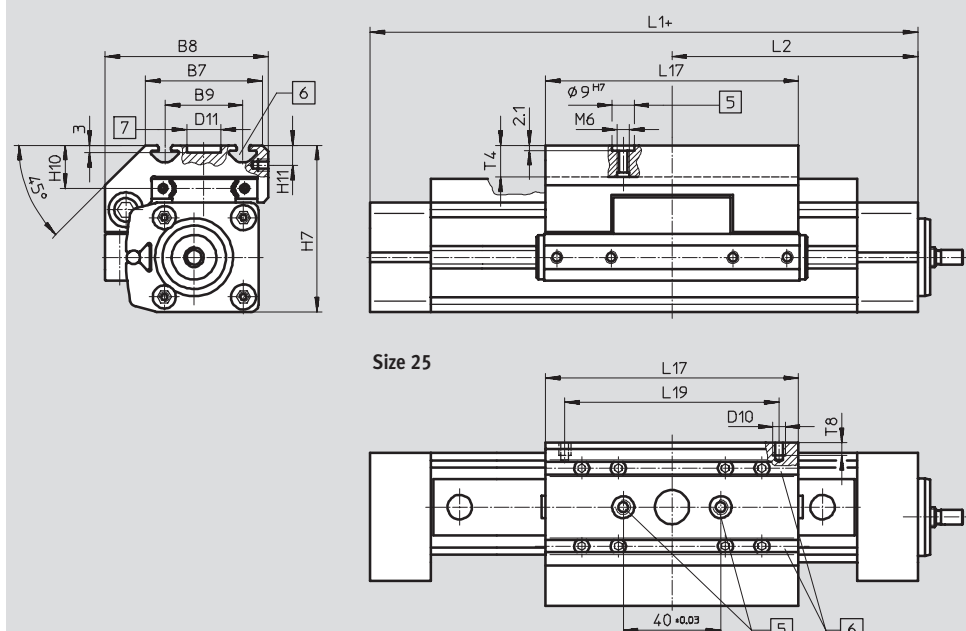

- 5 Hole for centring pin ZBH-9
- 6 Mounting slot for slot nut NSTL
- 7 Drilled hole for central mounting SLZZ

+ = plus stroke length

Basic dimensions  
→ 5 / 2.1-193

**Size 25**

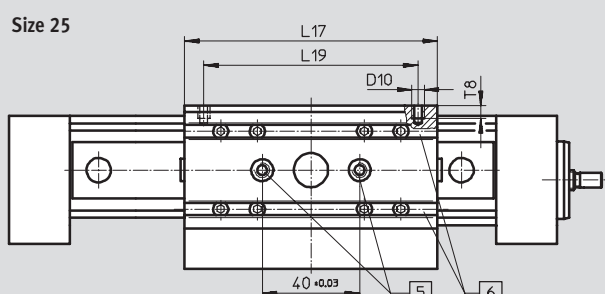

Size	B7	B8	B9	D10	D11	H7	H10	H11	L1	L2	L17	L19	T4	T8
			±0.2		∅ G7			+0.3				±0.1	max.	
25	48	67	32	M5	14	68.5	18.5	8.2	175	87.5	105	88	12.5	8.5
40	78.5	96.5	55	M5	25	90.5	20	7	250	126	167	150	12.5	8.5
63	121	142	90	M8	25	144.5	30	12.5	328	164	230	200	20.5	10.5

## Positioning axes DMES-GF/-KF, with guide

Technical data

### Dimensions

Download CAD data → [www.festo.com/en/engineering](http://www.festo.com/en/engineering)

Standard slide GK

Size 40/63

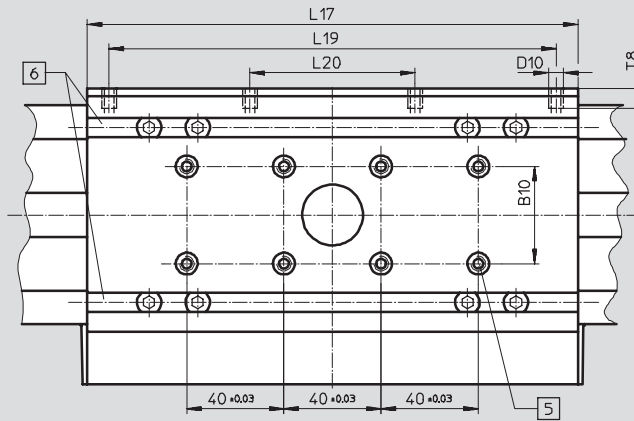

- 5 Hole for centring pin ZBH-9
- 6 Mounting slot for slot nut NSTL
- + = plus stroke length

### Additional slide KL/KR

Size 18

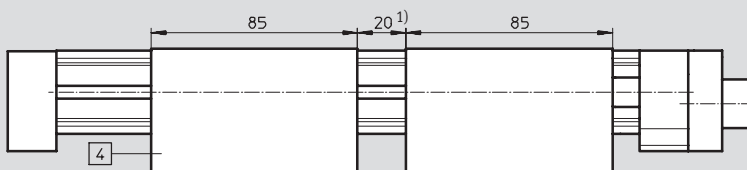

- 4 Additional slide  
DMES-...-KL/KR

1) Recommended minimum distance for access to lubrication nipple

### Size 25/40/63

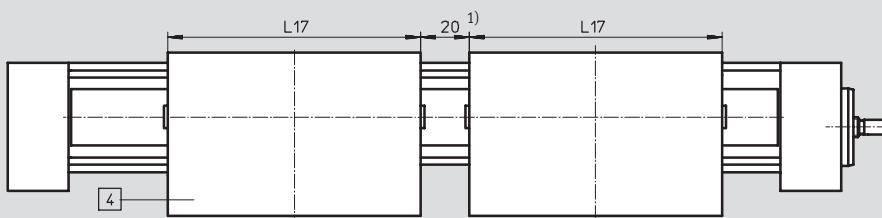

- 4 Additional slide  
DMES-...-KL/KR

1) Recommended minimum distance for access to lubrication nipple

Size	D10	L17	L19	L20	T8
25	M5	105	88	-	8.5
40	M5	167	150	58	8.5
63	M8	230	200	72	10.5



## Positioning axes DMES-GF/-KF, with guide

Technical data

**FESTO**

**Dimensions** Download CAD data → [www.festo.com/en/engineering](http://www.festo.com/en/engineering)

Profile

**Size 18**

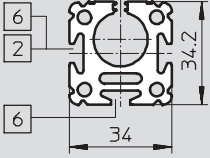

**Size 25**

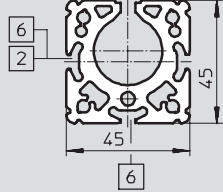

**Size 40**

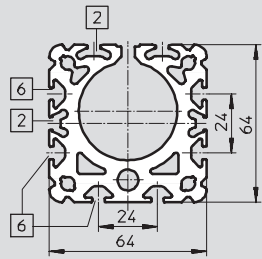

**Size 63**

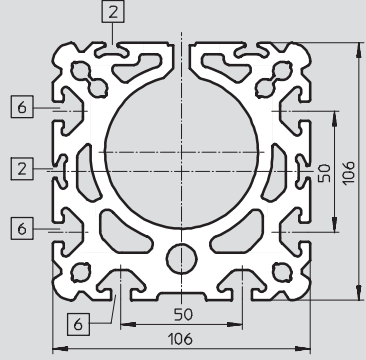

2 Sensor slot for proximity sensor

6 Mounting slot for slot nut NST

## Positioning axes DMES-GF/-KF, with guide

Technical data

### Dimensions

Download CAD data → [www.festo.com/en/engineering](http://www.festo.com/en/engineering)

Extended slide GV

Size 18

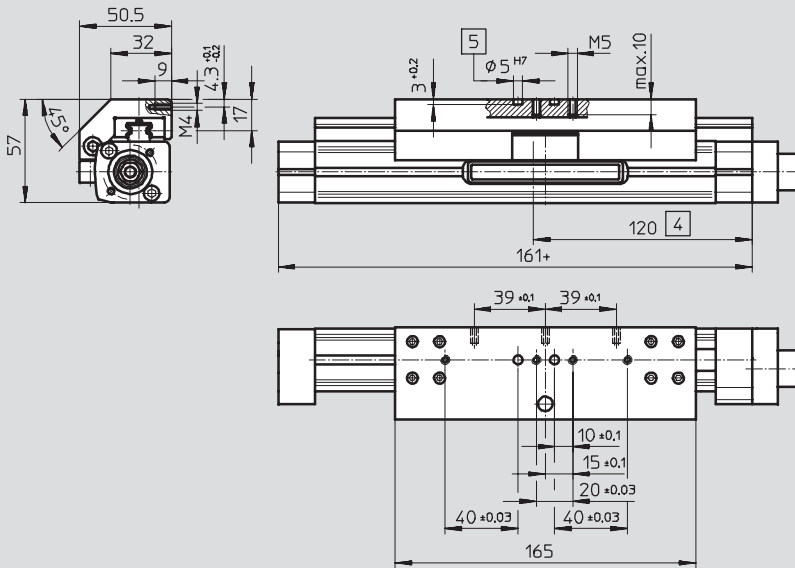

- 4 Lubrication opening
- 5 Hole for centring pin ZBS-5
- + = plus stroke length

Basic dimensions  
 → 5 / 2.1-193

## Positioning axes DMES-GF/-KF, with guide

Technical data

**FESTO**

**Dimensions** Download CAD data → [www.festo.com/en/engineering](http://www.festo.com/en/engineering)

Extended slide GV

Size 25/40/63

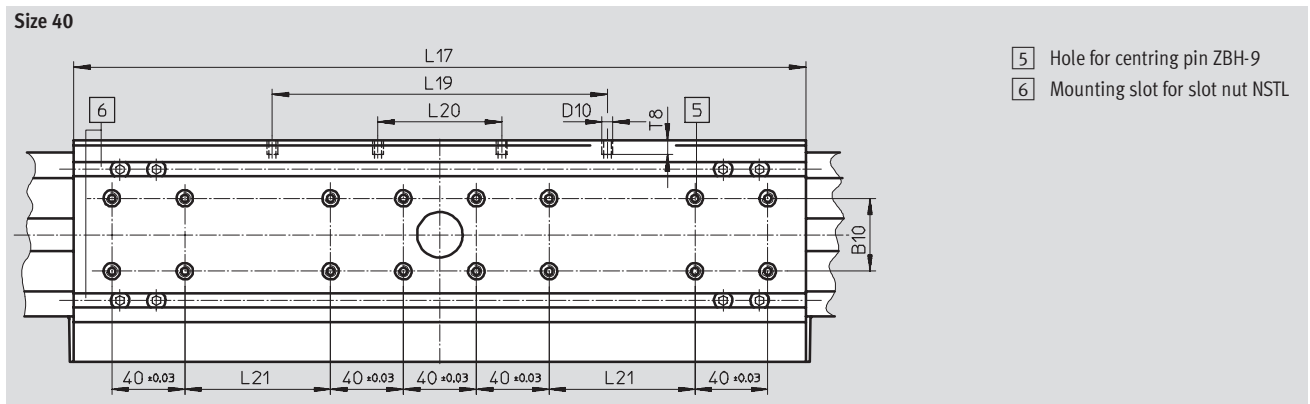
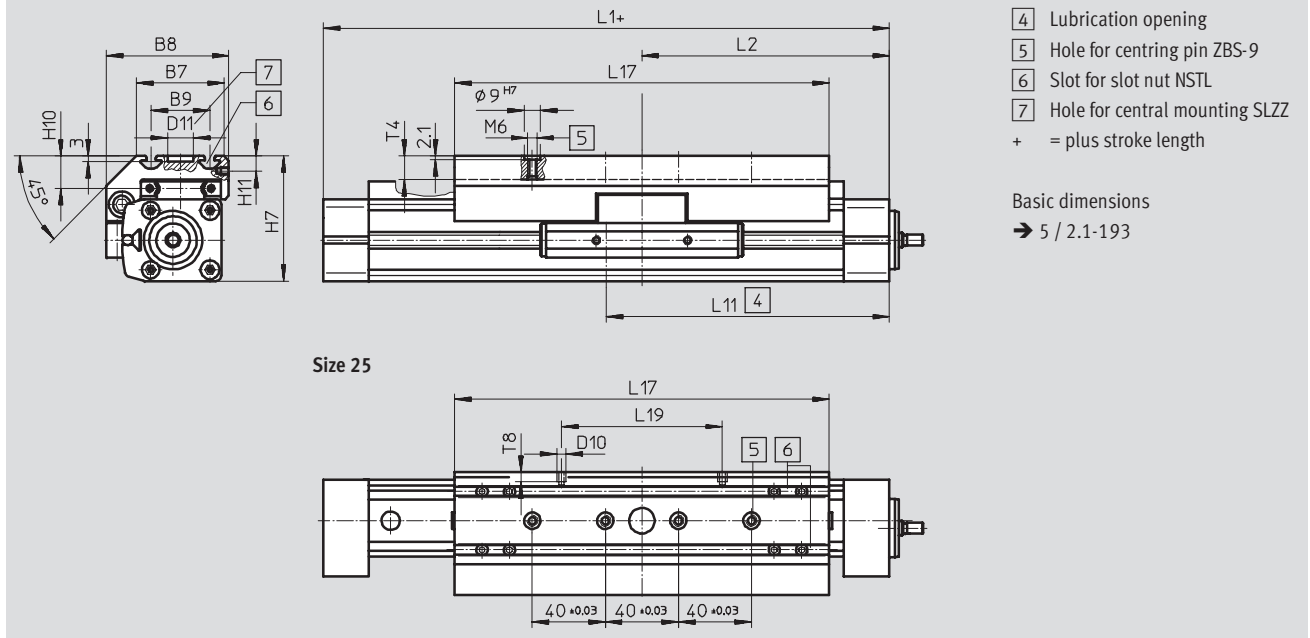

Size	B7	B8	B9	B10	D10	D11 Ø	H7	H10	H11
			±0.2			G7			+0.3
25	48	67	32	–	M5	14	68.5	18.5	8.2
40	78.5	96.5	55	20	M5	25	90.5	20	7
63	121	142	90	40	M8	25	144.5	30	12.5

Size	L1	L2	L11	L17	L19	L20	L21	T4	T8
				±0.1	±0.1	±0.1	±0.1	max.	
25	275	137.5	155	205	88	–	–	12.5	8.5
40	420	211	236	337	150	58	40	12.5	8.5
63	578	289	321	480	200	72	120	20.5	10.5

## Positioning axes DMES-GF/-KF, with guide

Technical data

### Dimensions

Download CAD data → [www.festo.com/en/engineering](http://www.festo.com/en/engineering)

Protected version GA

Size 18

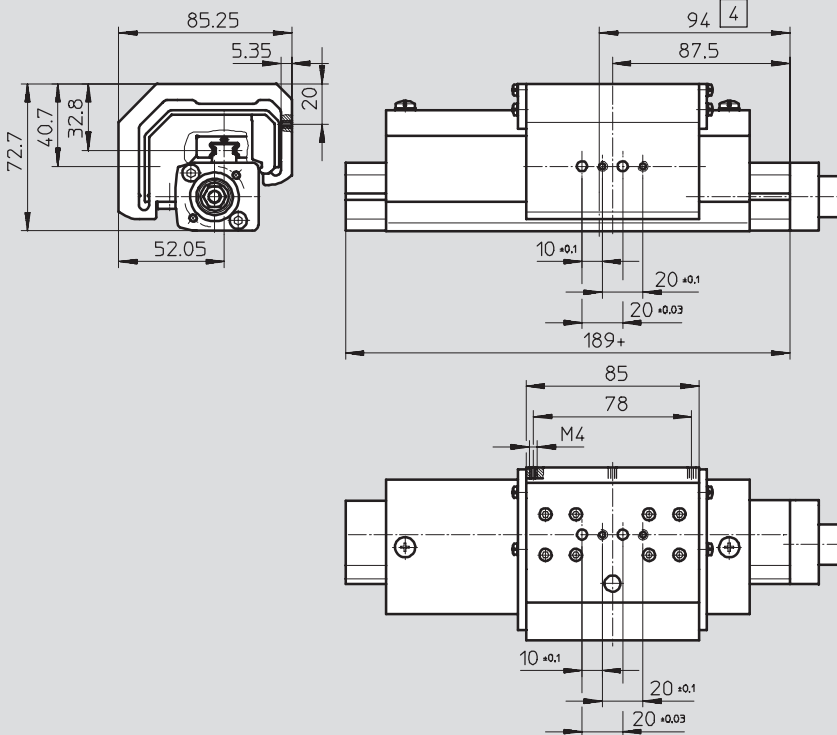

Size 25

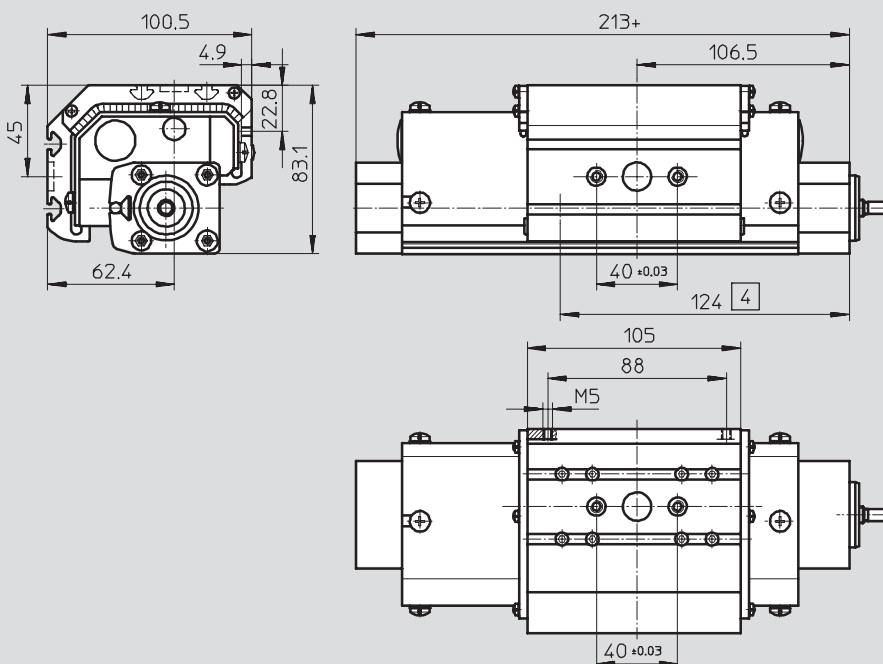

## Positioning axes DMES-GF/-KF, with guide

Technical data

**FESTO**

### Dimensions

Download CAD data → [www.festo.com/en/engineering](http://www.festo.com/en/engineering)

Protected version GA

Size 40

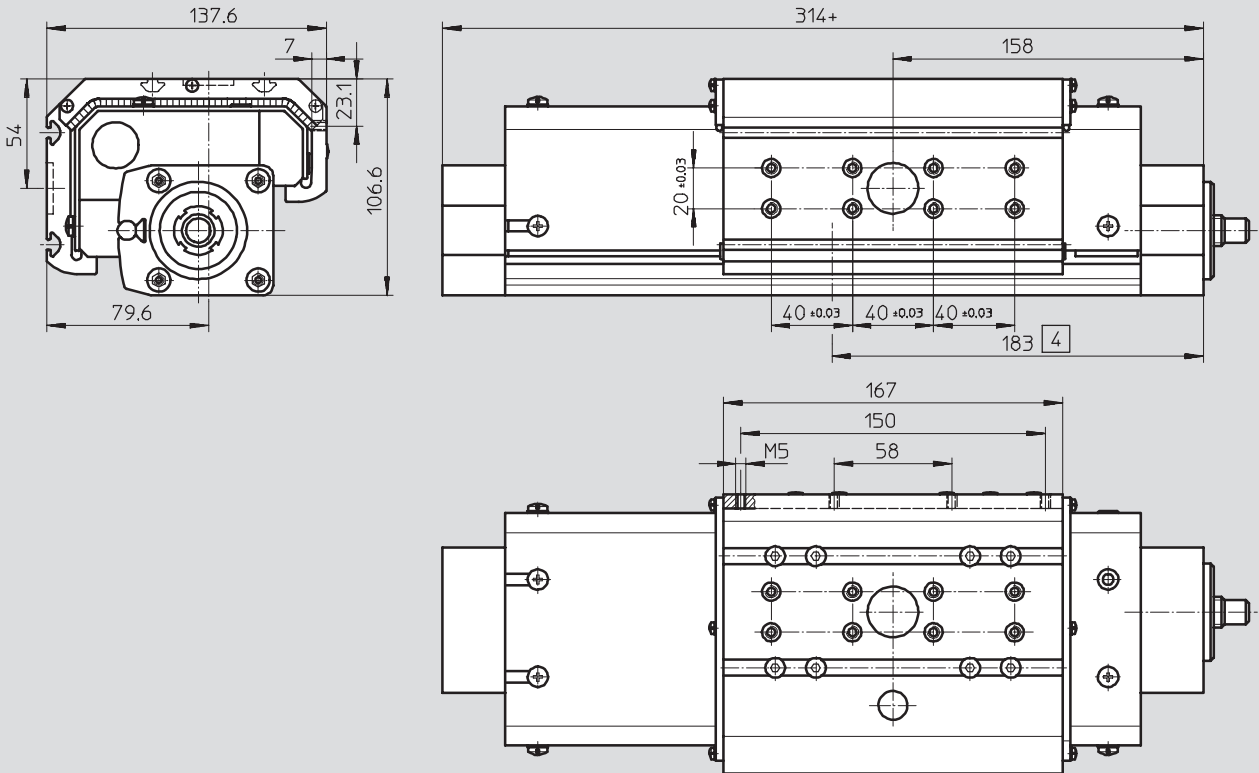

 Lubrication opening  
+ = plus stroke length

# Positioning axes DMES-GF/-KF, with guide

Ordering data – Modular products



## Order processing for positioning axis DMES in combination with motor unit MTR-DCI

1 Ordering positioning axis DMES      Ordering table → 5 / 2.1-222

The drive unit and corresponding accessories are configured in the ordering table for the positioning axis DMES.

The code "AX" is used to specify whether a motor unit and an axial kit are required for the positioning axis.

The motor unit design must be defined separately.

3 Ordering motor unit MTR-DCI      Ordering table → 5 / 2.2-9

The order code for the motor unit determined from table 2 must then be completed by adding the "gear unit" and "parameterisation interface" codes (for size 63 the "voltage" code must also be added).

The module number of the motor unit must not be specified when ordering with order code "AX". It is determined automatically.

## 2 Permissible combinations with motor unit MTR-DCI

Positioning axis	Motor unit
DMES-18-...	MTR-DCI-32S-VCSC-E...
DMES-25-...	MTR-DCI-42S-VCSC-E...
DMES-40-...	MTR-DCI-52S-VCSC-E...
DMES-63-...	MTR-DCI-62S-VDSC-E...

## 4 Order example

Part No.	Type
	Positioning axis DMES
533 700	DMES-25-700-KF-GK-SH-AX:ZUB-2S2Y1M1F
	Servo motor unit MTR-DCI
-	MTR-DCI-42S-VCSC-EG7-R210

# Positioning axes DMES-GF/-KF, with guide

Ordering data – Modular products

**Order code**  
Mandatory data  
DMES...-GK DMES...-GV

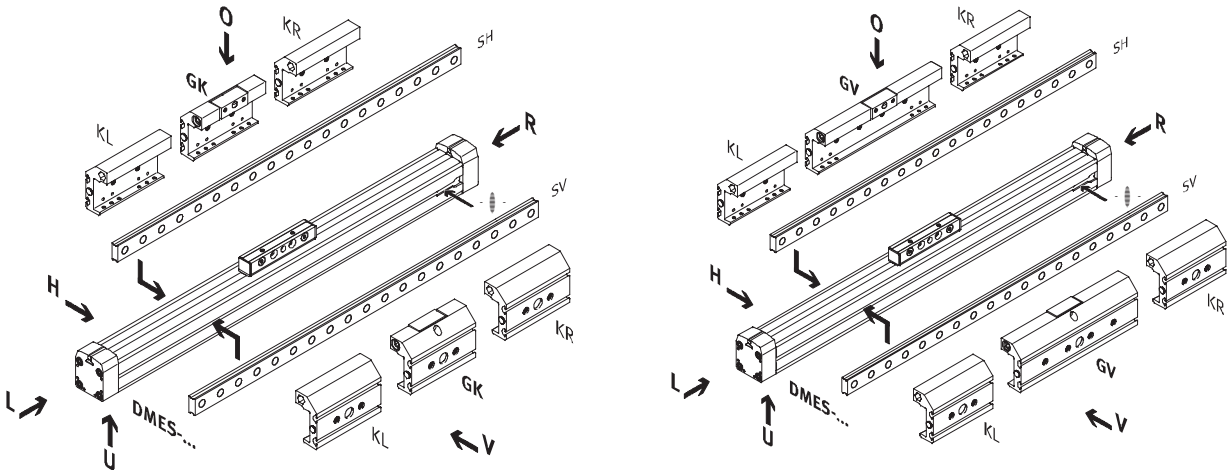

- Note  
The insertion point for the proximity sensor is located on the right-hand side of the positioning axis.

O	top
U	underneath
V	front
H	rear
R	right
L	left

**Order code**  
Options

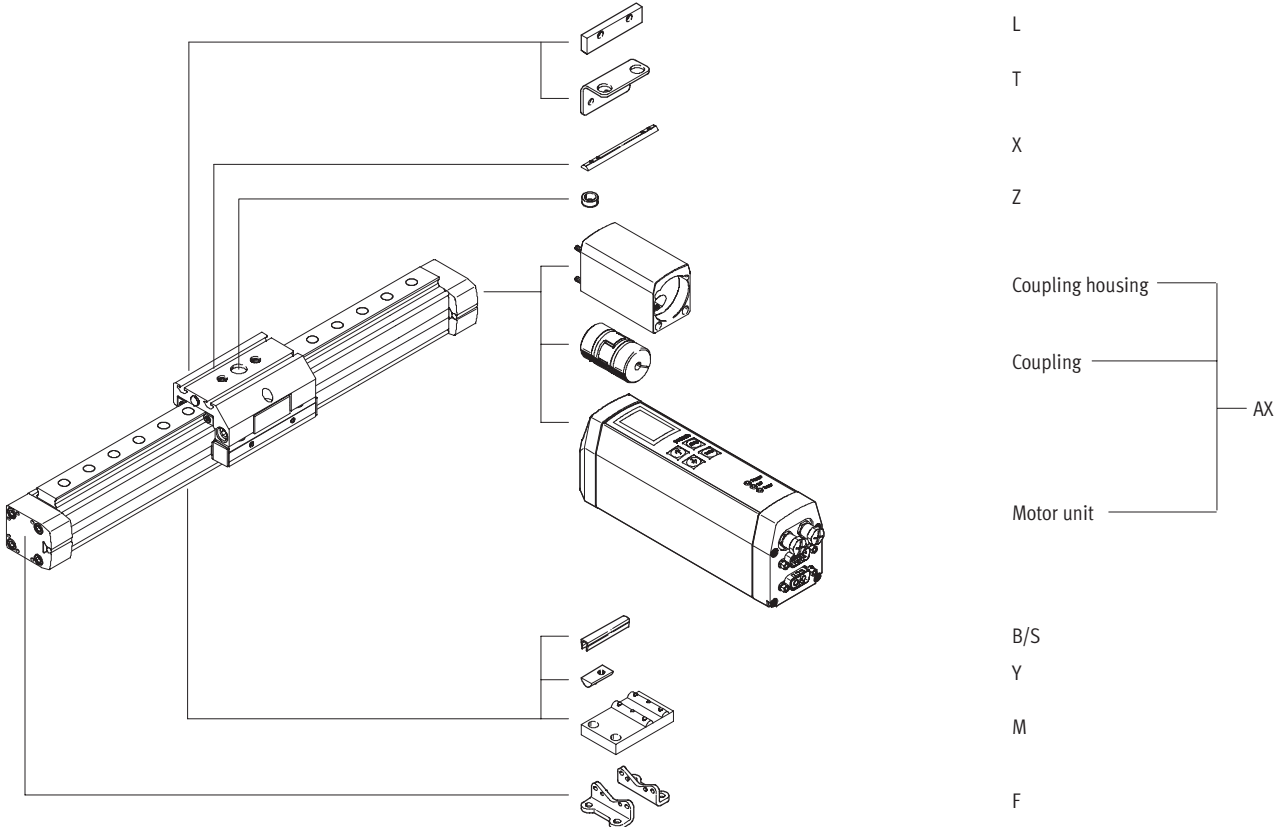

## Positioning axes DMES-GF/-KF, with guide

Ordering data – Modular products



Mandatory data				Options							
Module No.	Function	Size	Stroke	Guide	Guided slide	Slide attachment position	Additional slide	Motor unit	Accessories	Accessories supplied loose	
533 699	DMES	18	50 ... 1 800	GF	GK	SV	KL	AX		...S, ...B, ...Y, ...X, ...M, ...F, ...Z, ...T, L	
533 700		25		KF	GV	SH					KR
533 701		40		GA							
533 702		63									
<b>Order example</b>											
533 701	DMES	- 40	- 800	- KF	- GV	- SV	- KL	-	: ZUB	- 2X2M20Z	
MTR-DCI-...S-VCSC-E...-...IO											

Ordering table									
Size	18	25	40	63	Condi- tions	Code	Enter code		
M Module No.	533 699	533 700	533 701	533 702					
Function	Positioning axis with slide					DMES		DMES	
Size	18	25	40	63		-...			
Stroke [mm]	50 ... 400	50 ... 700	50 ... 1,200	50 ... 1,800		-...			
O Guide	Plain-bearing guide				1	-GF			
	Recirculating ball bearing guide				1	-KF			
Guided slide	Standard slide				2	-GK			
	Extended slide				2	-GV			
	Protected version				2	-GA			
Slide attachment position	Slide at front				2	-SV			
	Slide at rear				2	-SH			
Additional slide	Additional slide, standard, at left				3	-KL			
	Additional slide, standard, at right				3	-KR			
Motor unit	Axial kit for motor unit (enclosed separately)				4	-AX			
Accessories	Supplied separately					:ZUB-		:ZUB-	
Slot cover	Sensor slot	1 ... 10				...S			
	Mounting slot	-	-	1 ... 10		...B			
Slot nut	Mounting slot	1 ... 10				...Y			
	Guided slide	-	1 ... 10		2	...X			
Central support	1 ... 10					...M			
Foot mounting	1 ... 10					...F			
Centring sleeve (pack of 10)	10 ... 90				2	...Z			
Mounting bracket for inductive proximity sensors	1 ... 5				5	...T			
Switching lug	1				5	L			

- 1 **GF, KF** Only with slide GK, GV or GA and with slide attachment position SV or SH
- 2 **GK, GV, GA, SV, SH, X, Z** Only with guide GF or KF
- 3 **KL, KR** Only with guide KF (recirculating ball bearing guide) and with slide GK or GV
- 4 **AX** Order processing for motor unit MTR-DCI → 5 / 2.2.9
- 5 **T, L** Only with slide GK or GV

**Transfer order code**

**DMES** -  -  -  -  -  -  -  : **ZUB** -

MTR-DCI-...S-...SC-E...-...IO



# Positioning axes DMES

Accessories – Motor units MTR-DCI



**M** Mandatory data

Module No.	Motor unit	Motor type	Flange/size	Torque class	Nominal voltage	Plug design	Measuring system	Gearing	Parameterisation interface	Electrical connection technology
Order example	MTR	DCI	32 42 52 62	S	VC VD	SC	E	G7 G14 G22	R2 H2	IO
	<b>MTR</b>	<b>-DCI</b>	<b>-42</b>	<b>S</b>	<b>-VC</b>	<b>SC</b>	<b>-E</b>	<b>G7</b>	<b>-R2</b>	<b>IO</b>

**Ordering table**

Size	32	42	52	62	Condi- tions	Code	Enter code
<b>M</b> Module No.	<b>533 736</b>			<b>533 754</b>			
Motor unit	Motor unit					<b>MTR</b>	MTR
Motor type	DC servo motor with integrated position controller					<b>-DCI</b>	-DCI
Flange/size	32	42	52	62		<b>-...</b>	
Torque class	Standard torque class					<b>S</b>	S
Nominal voltage	[V] 24 DC					<b>-VC</b>	
	[V] -			48 DC		<b>-VD</b>	
Plug design	Straight plug					<b>SC</b>	SC
Measuring system	Encoder					<b>-E</b>	-E
Gearing	Integrated planetary gearing i = 6.75					<b>G7</b>	
	Integrated planetary gearing i = 13.73					<b>G14</b>	
			Integrated planetary gearing i = 22.21			<b>G22</b>	
Parameterisation interface	RS232 interface					<b>-R2</b>	
	RS232 interface + control panel					<b>-H2</b>	
Electrical connection technology	I/O connection					<b>IO</b>	IO

Electrical positioning systems  
Electromechanical drives

2.1

# Positioning axes DMES

Accessories



Permissible combinations with servo-motor unit MTR-DCI						
Order code/ Gearing type	Servo-motor unit		Coupling housing		Coupling	
	Part No.	Type	Part No.	Type	Part No.	Type
<b>Size 18</b>						
G7	533 736	MTR-DCI-32S-...-G7-...	533 703	DME-KG-18-AX-D32-L27	533 707	KSE-15-20-D05-D06
G14	533 736	MTR-DCI-32S-...-G14-...				
<b>Size 25</b>						
G7	533 742	MTR-DCI-42S-...-G7-...	533 704	DME-KG-25-AX-D42-L88	533 708	KSE-30-32-D06-D08
G14	533 742	MTR-DCI-42S-...-G14-...	538 578	DME-KG-25-AX-D42-L101		
<b>Size 40</b>						
G7	533 748	MTR-DCI-52S-...-G7-...	533 705	DME-KG-40-AX-D52-L121	533 709	KSE-42-50-D12-D12
G14	533 748	MTR-DCI-52S-...-G14-...	538 579	DME-KG-40-AX-D52-L135		
<b>Size 63</b>						
G7	533 754	MTR-DCI-62S-...-G7-...	533 706	DME-KG-63-AX-D62-L150	533 710	KSE-42-50-D14-D20
G14	533 754	MTR-DCI-62S-...-G14-...				
G22	533 754	MTR-DCI-62S-...-G22-...				

Ordering data						Technical data → Volume 1	
	For size	Remarks	Order code	Part No.	Type	PU <sup>1)</sup>	
<b>Slot nut NST</b>							
	18/25	For mounting slot	Y	526 091	NST-HMV-M4	10	
	40			150 914	NST-5-M5	1	
	63			150 915	NST-8-M6	1	
<b>Slot nut NSTL</b>							
	25	For slide	X	158 410	NSTL-25	1	
	40			158 412	NSTL-40	1	
	63			158 414	NSTL-63	1	
<b>Centring pin ZBS/centring sleeve ZBH</b>							
	18	For slide	Z	150 928	ZBS-5	10	
	25/40/63			150 927	ZBH-9	10	
<b>Slot cover ABP</b>							
	40	For mounting slot every 0.5 m	B	151 681	ABP-5	2	
	63			151 682	ABP-8	2	
<b>Slot cover ABP-S</b>							
	18/25/40/63	For sensor slot every 0.5 m	S	151 680	ABP-5-S	2	

1) Packaging unit quantity

# Positioning axes DMES

Accessories



**Foot mounting HP**  
(order code F)

Material:  
Galvanised steel  
Free of copper, PTFE and silicone



HP-25

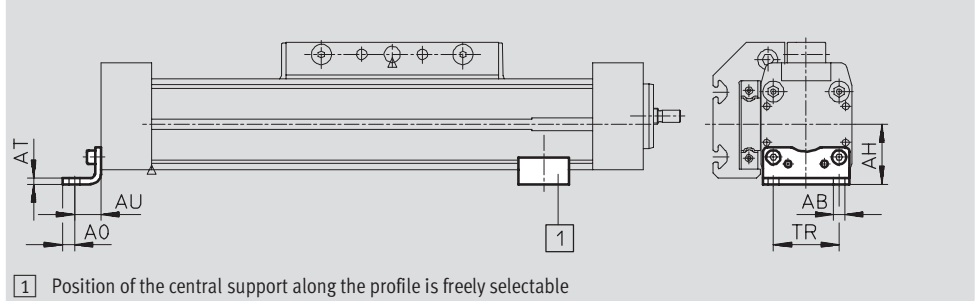

Dimensions and ordering data										
For size	AB ∅	AH	AO	AT	AU	TR	Weight [g]	Part No.	Type	
18	5.5	24	4.8	3	13.2	24	59	158 472	HP-18	
25	5.5	29.5	6	3	13	32.5	61	150 731	HP-25	
40	6.6	46	8.5	5	17.5	45	188	150 733	HP-40	
63	11	69	13.5	6	28	75	305	150 735	HP-63	

**Central support MUP**  
(order code M)

Material:  
Galvanised steel  
Free of copper, PTFE and silicone



MUP-40

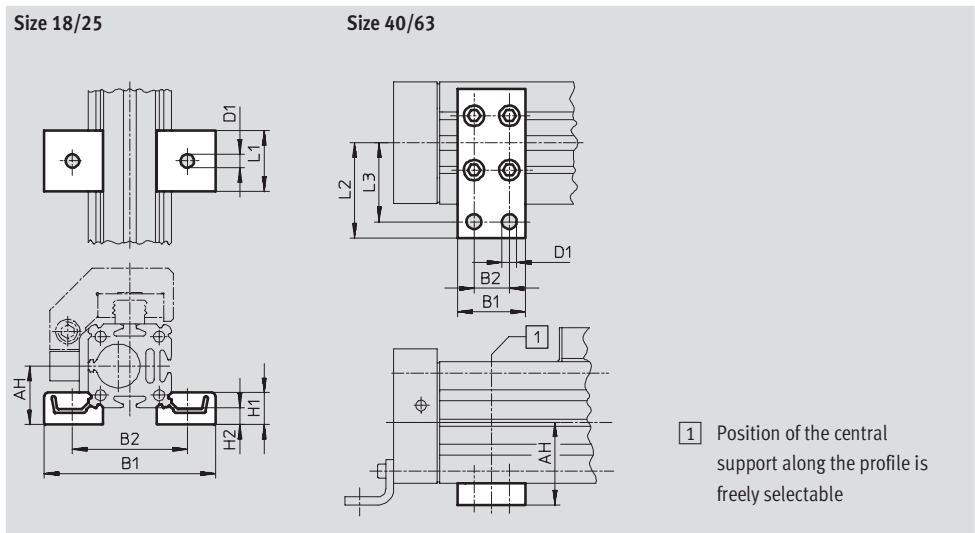

Dimensions and ordering data												
For size	AH	B1	B2	D1 ∅	H1	H2	L1	L2	L3	Weight [g]	Part No.	Type
18	24	70.5	47	5.5	13	7	25	-	-	33	150 736	MUP-18/25
25	29.5	81	58	5.5	13	7	25	-	-	33	150 736	MUP-18/25
40	46	35	22	6.6	-	-	-	47	40	126	150 738	MUP-40
63	69	50	26	11	-	-	-	77	65	340	150 800	MUP-63

# Positioning axes DMES

Accessories



## Sensor retainer HWS

For inductive proximity sensors

(order code: T)

Material:

Galvanised steel



## Switching lug SF

(order code: L)

Material:

Galvanised steel



Size 18/25

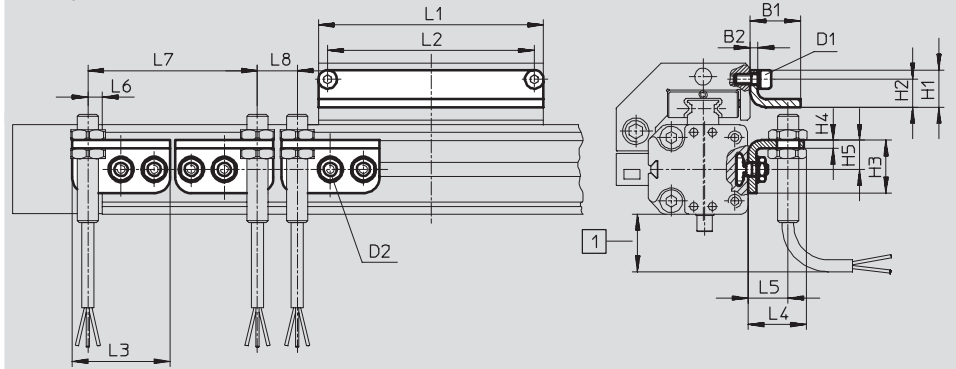

Size 40/63

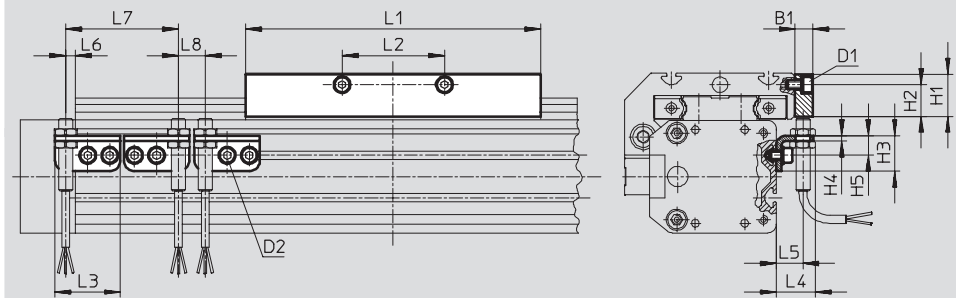

1 Protruding sensor cable, ensure sufficient installation space

Dimensions and ordering data														
For size	D1	D2	B1	B2	H1	H2	H3	H4	H5	L1	L2	L3	L4	L5
18	M4	M5	19	3	14	10.5	20	3	11	85	78	37	22.5	15
25	M5	M5	27	3	20.5	15.3	20	3	11	105	88	37	34.5	27
40	M5	M5	10	-	24	18	20	3	11	167	58	37	22.5	15
63	M8	M5	10	-	35	25	20	3	11	230	72	37	22.5	15

For size	L6	L7	L8	Weight	Part No.	Type
	max.	min.	min.	[g]		
18	5.5	64	15	34	188 968	HWS-18/25-M8
				59	188 964	SF-18
25	5.5	64	15	34	188 968	HWS-18/25-M8
				75	188 965	SF-25
40	5.5	64	15	37	188 969	HWS-40-M8
				328	188 966	SF-40
63	5.5	64	15	45	188 970	HWS-63-M8
				630	188 967	SF-63





# Positioning axes DMES



Accessories



FESTO

Electrical positioning systems  
Electromechanical drives

2.1

Ordering data – Inductive proximity sensors M8						Technical data → Volume 4	
	Electrical connection		Switch out-put	LED	Cable length [m]	Part No.	Type
	Cable	M8 plug					
<b>N/O contact</b>							
	3-wire	–	PNP	■	2.5	150 386	SIEN-M8B-PS-K-L
	–	3-pin	PNP	■		150 387	SIEN-M8B-PS-S-L
<b>N/C contact</b>							
	3-wire	–	PNP	■	2.5	150 390	SIEN-M8B-PO-K-L
	–	3-pin	PNP	■		150 391	SIEN-M8B-PO-S-L

Ordering data – Proximity sensor for T-slot, magneto-resistive						Technical data → 1 / 10.2-13		
	Assembly	Switch out-put	Electrical connection			Cable length [m]	Part No.	Type
			Cable	M8 plug	M12 plug			
<b>N/O contact</b>								
	Insertable from end, flush with the cylinder profile	PNP	3-wire	–	–	2.5	175 436	SMT-8-PS-K-LED-24-B
			–	3-pin	–	0.3	175 484	SMT-8-PS-S-LED-24-B
	Insertable from above	PNP	–	3-pin	–	0.3	525 899	SMT-8F-PS-24V-K0,3-M8D
		NPN	–	3-pin	–		525 910	SMT-8F-NS-24V-K0,3-M8D

Ordering data – Proximity switch for T-slot, magnetic reed						Technical data → 1 / 10.2-18	
	Assembly	Electrical connection			Cable length [m]	Part No.	Type
		Cable	M8 plug				
<b>N/O contact</b>							
	Insertable from above	–	3-pin	–	0.3	525 896	SME-8F-DS-24V-K0,3-M8D
	Insertable from end, flush with the cylinder profile	3-wire	–	–	2.5	150 855	SME-8-K-LED-24
		–	3-pin	–	0.3	150 857	SME-8-S-LED-24
<b>N/C contact</b>							
	Insertable from end, flush with the cylinder profile	3-wire	–	–	7.5	160 251	SME-8-O-K-LED-24

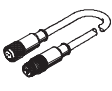
Ordering data – Connecting cable					Technical data → 1 / 10.2-114	
	Assembly	Connection	Cable length [m]	Part No.	Type	
<b>Straight socket</b>						
	Union nut M8, both ends	3-pin	0.5	175 488	KM8-M8-GSGD-0,5	
			1	175 489	KM8-M8-GSGD-1	
			2.5	165 610	KM8-M8-GSGD-2,5	
			5	165 611	KM8-M8-GSGD-5	

