



- Strength in motion
- Precision measurement
- Two perfect partners – Servo-pneumatic drive technology

Cylinders with displacement encoder

Key features

At a glance

- Displacement encoder, integrated or attached
- Absolute measurements
- Long service life
- As a measuring cylinder
- For Soft Stop with end position controller SPC11
- For positioning with axis controller SPC200

Standard cylinder DNCI, internal displacement encoder

- Piston \varnothing 32 ... 63 mm
- Stroke lengths of 10 ... 2 000 mm
- Contactless measuring, integrated displacement encoder
- Various piston rod variants
- Based on standard cylinder DNC



DIN



NF E 49 003.1
UNI 10 290



Standard cylinder DNCM, external displacement encoder

- Piston \varnothing 32 and 50 mm
- Fixed stroke lengths of 100 ... 500 mm
- Encoder attached
- Various piston rod variants
- Based on standard cylinder DNC



DIN



NF E 49 003.1
UNI 10 290



Linear drives DGPL, external displacement encoder

- Piston \varnothing 25 ... 63 mm
- Stroke lengths of 225 ... 2,000 mm
- With encoder or with contactless measuring displacement encoder
- With or without guide
- With clamping unit
- Wide range of options for mounting on drive units
- System product for handling and assembly technology

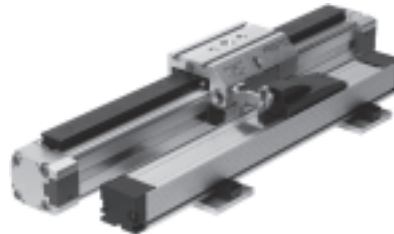

Linear drives DGPI/DGPII, internal displacement encoder

- Piston \varnothing 25 ... 63 mm
- Stroke lengths of 225 ... 2,000 mm
- Contactless measuring, integrated displacement encoder
- Compact design
- With or without guide
- With protected version
- Wide range of options for mounting on drive units
- System product for handling and assembly technology



Swivel module DSMI, internal displacement encoder

- Sizes: 25 and 40 mm
- Swivel angle 270°
- Rotary encoder integrated
- Compact design
- Wide choice of mounting options



Cylinders with displacement encoder

Product range overview

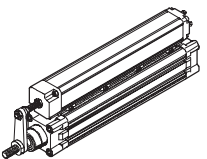
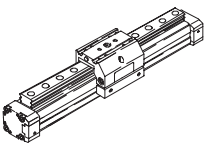
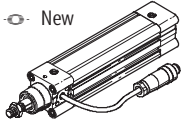
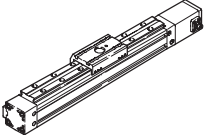
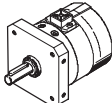
Function	Type	Piston \varnothing [mm]	Stroke/Swivel angle [mm/°]	Description	→ Page
Linear drives	External displacement encoder				
	DNCM 	32, 50	100, 160, 200, 250, 320, 400, 500	Piston rod drive, based on standard cylinder DNC, with attached displacement encoder	5 / 1.1-22
	DGP/DGPL 	25, 32, 40, 50, 63	225, 300, 360, 450, 500, 600, 750, 1,000, 1,250, 1,500, 1,750, 2,000	DGP: Linear drive without guide, with external displacement encoder (must be assembled by the customer)	Drive: 5 / 1.1-38 Displacement encoder: 5 / 1.2-2
				DGPL: Linear drive with guide and attached displacement encoder	5 / 1.1-38
	Internal displacement encoder				
	DNCI 	32, 40, 50, 63	10 ... 2,000	Piston rod drive, based on standard cylinder DNC, with integrated displacement encoder	5 / 1.1-4
DGPI/DGPIL 	25, 32, 40, 50, 63	225, 300, 360, 450, 500, 600, 750, 1,000, 1,250, 1,500, 1,750, 2,000	Linear drive, with or without a guide, with integrated displacement encoder	5 / 1.1-56	
Swivel modules	Internal displacement encoder				
	DSMI 	25, 40	270	Swivel module, based on swivel module DSM, with integrated rotary encoder	5 / 1.1-92

Standard cylinders DNCI, with integrated displacement encoder

Key features



Servopneumatic positioning systems
Cylinders with displacement encoders

1.1

Components for positioning and measuring using the standard cylinder DNCI



Positioning with end-position controller SPC11 or axis controller SPC200

Proportional directional control valve
MPYE-...
→ 5 / 1.5-2



Soft Stop
→ 5 / 1.4-2

Closed loop end-position controller
SPC11-INC



Positioning technology
→ 5 / 1.3-2

Axis interface
SPC-AIF-INC



Axis controller
SPC200



Measuring with measuring transducer DADE

Measuring transducer
DADE-...
→ 5 / 1.1-118



PLC controller
e.g. FEC-...
→ Volume 4



Display and control unit
e.g. FED-...
→ Volume 4



Standard cylinders DNCI, with integrated displacement encoder

Type code

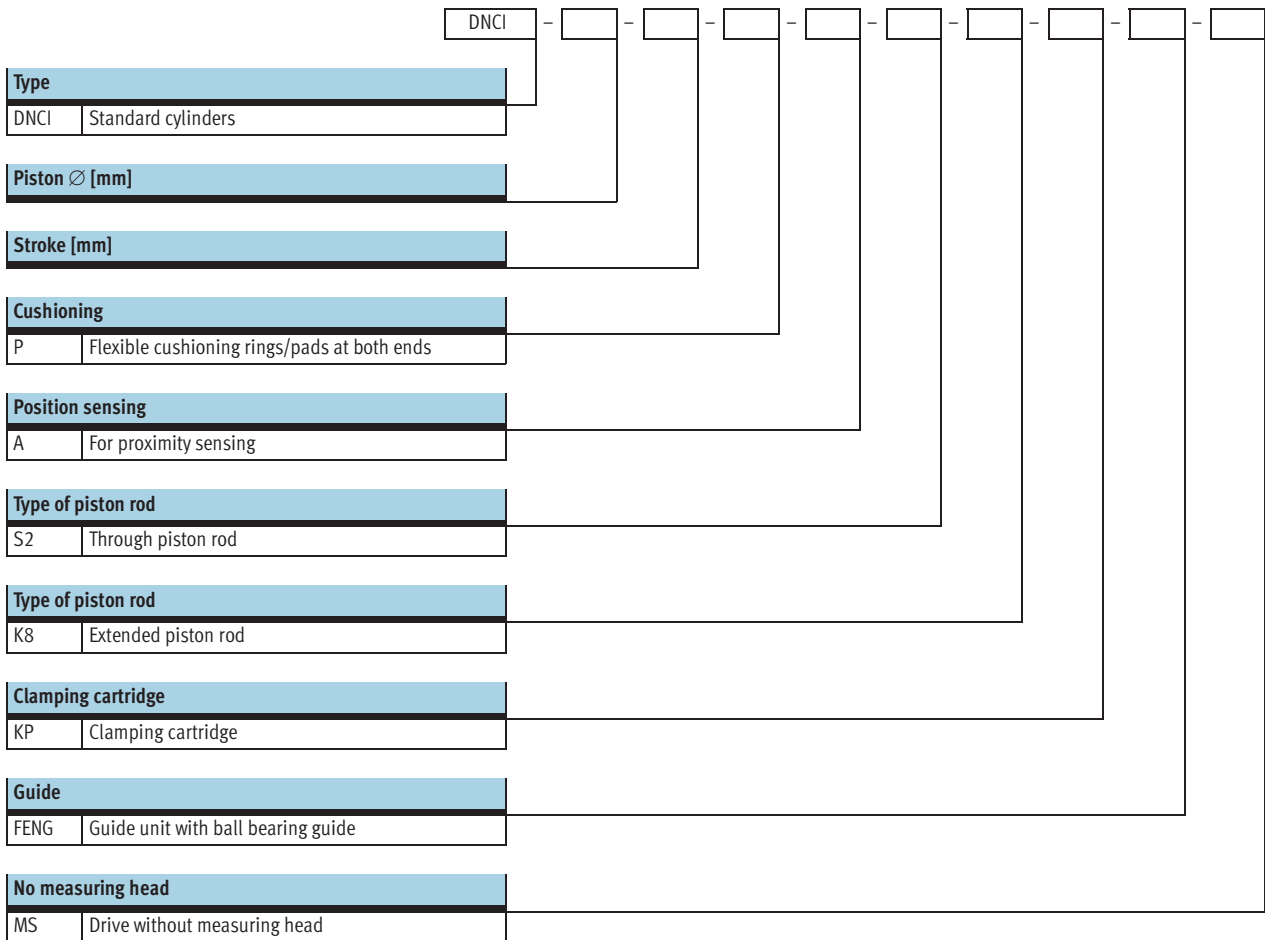

Standard cylinders DNCI, with integrated displacement encoder

Peripherals overview



Servopneumatic positioning systems
Cylinders with displacement encoders

1.1

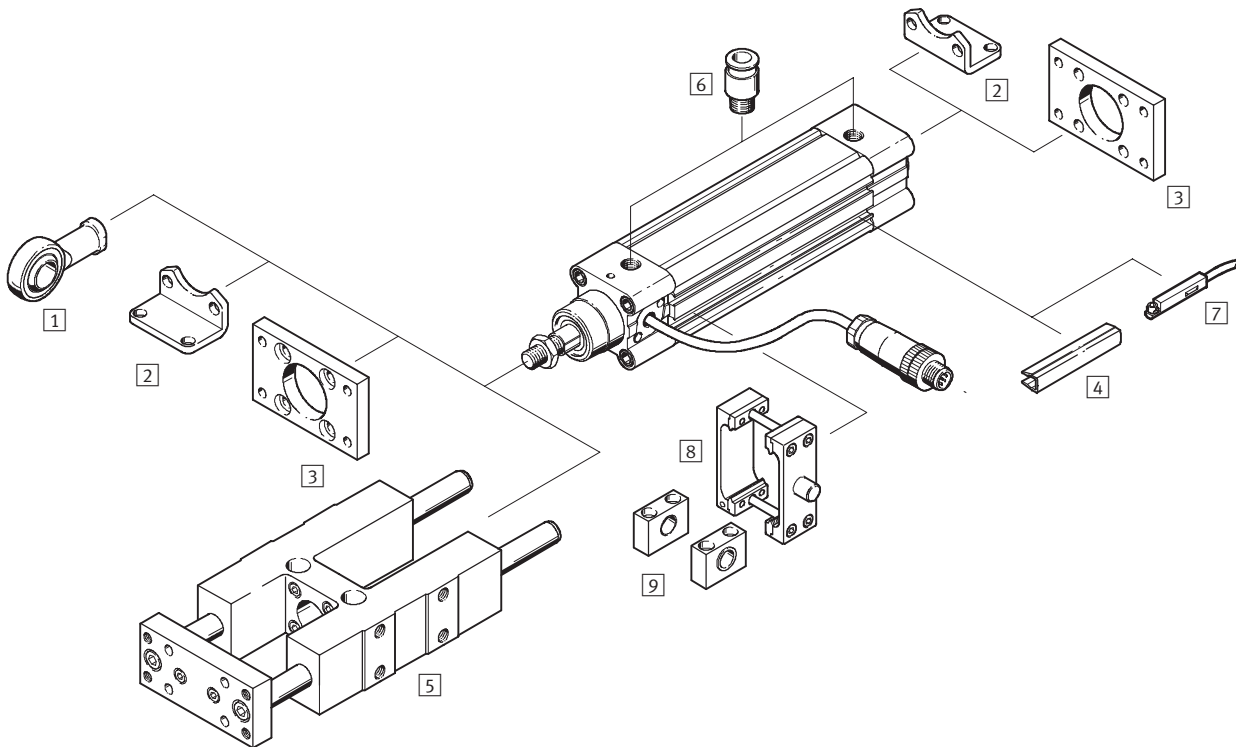

 Note
If the drive DNCI is used without an end position controller SPC11 or an axis controller SPC200, e.g. as a measuring cylinder, then the standard accessories of the drive DNC can be used.

Standard cylinders DNCI, with integrated displacement encoder

Peripherals overview

Accessories		
Type	Brief description	→ Page
1 Rod eye SGS	With spherical bearing	5 / 1.1-19
2 Foot mounting HNC	For mounting the drive on the bearing and end cap	5 / 1.1-18
3 Flange mounting FNC	For mounting the drive on the bearing and end cap	5 / 1.1-19
4 Slot cover ABP-5-S	For protecting against ingress of dirt	5 / 1.1-21
5 Guide unit ¹⁾ FENG-KF	For protecting against torsion at high torque loads	5 / 1.1-16
6 Push-in fitting QS	For connecting compressed air tubing with standard external diameters	5 / 1.1-21
7 Proximity sensor SME/SMT-8	For additional sensing of the piston position, can be ordered optionally, only in conjunction with the order code A in the drive's modular product section	Volume 1
8 Trunnion mounting kit ZNCM	For swivelling movements of the drive	5 / 1.1-20
9 Trunnion support LNZG	For securing the trunnion mounting kit ZNCM	5 / 1.1-20

1) Guide unit FENG-KF must be attached to the piston rod such that backlash is eliminated

Standard cylinders DNCI, with integrated displacement encoder

Technical data



Function

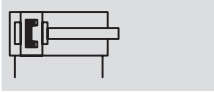
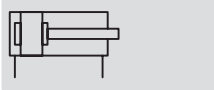

- - Diameter
32 ... 63 mm
- - Stroke length
10 ... 2,000 mm

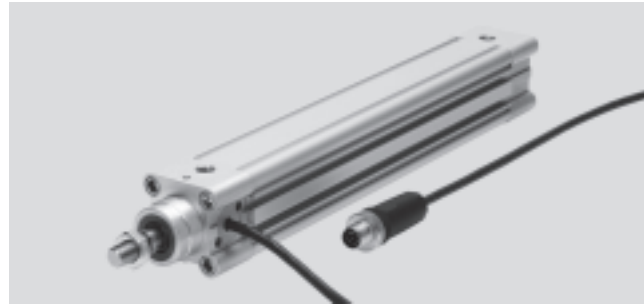

General technical data				
Piston \varnothing	32	40	50	63
Constructional design	Piston Piston rod Profile barrel			
Mode of operation	Double-acting			
Cushioning	Flexible cushioning rings/pads at both ends			
Position sensing	Integrated displacement encoder For proximity sensing ¹⁾			
Measuring principle (displacement encoder)	Digital			
Type of mounting	Foot mounting			
Stroke ²⁾⁴⁾	[mm] 10 ... 2,000			
Torsion protection/Guide ³⁾	Guide rod with yoke, with ball bearing guide			
Stroke	[mm] 100 ... 500			
Piston rod extension	[mm] 1 ... 500			
Pneumatic connection	G $\frac{1}{8}$	G $\frac{1}{4}$	G $\frac{1}{4}$	G $\frac{3}{8}$
Electrical connection	Cable with 8-pin plug, round type M12			
Cable length	[m] 1.5			

- 1) Not included in the scope of delivery, can be ordered as an option
- 2) Note stroke reduction in conjunction with SPC200
- 3) Guide unit FENG-KF must be ordered as an option and will be supplied attached, the max. stroke is reduced
- 4) Can only be used as a positioning drive without reservation in the range from 100 ... 500 mm

Forces [N] and impact energy [Nm]				
Piston \varnothing	32	40	50	63
Theoretical force at 6 bar advancing	483	754	1,178	1,870
Theoretical force at 6 bar retracting	415	633	990	1,682
Impact energy at end positions	0.1	0.2	0.2	0.5

Permissible impact velocity:

$$v_{\text{perm.}} = \sqrt{\frac{2 \times E_{\text{perm.}}}{m_{\text{dead}} + m_{\text{load}}}}$$

Maximum permissible load:

$$m_{\text{load}} = \frac{2 \times E_{\text{perm.}}}{v^2} - m_{\text{dead}}$$

- - Note

This data represents the maximum values that can be achieved. Values fluctuate in practice relative to the size of the effective load. Allowance

must also be made for the limits of the cushioning capacity of the drive and the permissible impact energy.

Standard cylinders DNCI, with integrated displacement encoder

Technical data

Operating and environmental conditions		
Operating pressure ¹⁾	[bar]	4 ... 8
Operating medium ²⁾		Compressed air, filtered and unlubricated, filter unit 5 µm
Ambient temperature ³⁾	[°C]	-20 ... +80
Vibration resistance		To DIN/IEC 68 Parts 2 – 6, severity level 2
Continuous shock resistance		To DIN/IEC 68 Parts 2 – 82, severity level 2
CE symbol (declaration of conformance)		In accordance with EU EMC Directive
Protection class (displacement encoder)		IP65 to IEC 60 529
Corrosion resistance class CRC ⁴⁾		1

- 1) Only applies for applications with the Soft Stop end position controller SPC11 and axis controller SPC200
- 2) The proportional directional control valve MPYE used requires the characteristic values
- 3) Note operating range of proximity sensors
- 4) Corrosion resistance class 1 according to Festo standard 940 070
Components requiring low corrosion resistance. Transport and storage protection. Parts that do not have primarily decorative surface requirements, e.g. in internal areas that are not visible or behind covers.

Weights [g] with displacement encoder					
Piston Ø		32	40	50	63
Basic drive DNCI-...					
	Product weight with 0 mm stroke	521	853	1,319	1,914
	Additional weight per 10 mm stroke	30	44	62	71
	Moving load with 0 mm stroke	95	175	316	383
	Additional weight per 10 mm stroke	8	14	23	23
Drive with through piston rod DNCI-...-S2					
	Product weight with 0 mm stroke	586	981	1,553	2,165
	Additional weight per 10 mm stroke	39	60	87	96
	Moving load with 0 mm stroke	155	164	297	364
	Additional weight per 10 mm stroke	17	30	48	48
Additional weight with extended piston rod K8					
	Additional weight per 10 mm stroke	8	14	23	23
Additional weight with clamping cartridge KP					
	Product weight	234	394	700	1,147
Additional weight with guide unit FENG-...					
	Product weight with 0 mm stroke	1,530	2,370	4,030	5,410
	Additional weight per 10 mm stroke	18	32	50	62

Materials

Sectional view	
Standard cylinders	
1) Piston rod	High-alloy steel
2) Cylinder barrel	Anodised aluminium
3) Bearing/end caps	Die-cast aluminium
- Dynamic seals	Polyurethane TPE-U
- Static seals	Nitrile rubber
- Lubricant	Klüberplex BE31-102
Displacement encoder	
- Sensor housing	Polyacetate
- Cable sheath	Polyurethane
- Plug housing	Polybuteneterephthalate
- Wall mounting plate	Polyacetate
- Screws for mounting plate	Steel

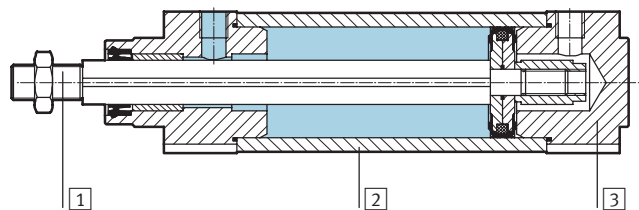

Standard cylinders DNCI, with integrated displacement encoder

FESTO

Technical data

Positioning characteristics with axis controller SPC200						
Piston Ø			32	40	50	63
Repetition accuracy	horizontal	[mm]	< ±0.5			
	vertical	[mm]	< ±0.5			
Assembly position			Any			
Minimum load, horizontal		[kg]	3	5	8	12
Maximum load, horizontal		[kg]	45	75	120	180
Minimum load, vertical ¹⁾		[kg]	3	5	8	12
Maximum load, vertical ¹⁾		[kg]	15	25	40	60
Min. travel speed		[m/s]	0.05			
Max. speed of travel		[m/s]	1.5			
Typ. positioning time, long stroke ³⁾		[s]	0.45/0.70	0.50/0.75	0.65/0.80	0.55/0.75
Typ. positioning time, short stroke ⁴⁾		[s]	0.35/0.55	0.40/0.55	0.45/0.60	0.40/0.55
Minimum positioning stroke ²⁾		[%]	< 3			
Stroke reduction ⁵⁾		[mm]	10		15	
Recommended proportional directional control valve			→ 5 / 1.1-21			

- 1) Only in conjunction with an external guide
- 2) In relation to the maximum stroke of the drive, but never more than 20 mm
- 3) At 6 bar, horizontal mounting position, DNCI-XX-500, 400 mm positioning travel at min./max. load
- 4) At 6 bar, horizontal mounting position, DNCI-XX-500, 100 mm positioning travel at min./max. load
- 5) The stroke reduction is to be maintained on every side of the drive, the max. positionable stroke is therefore: stroke – 2x stroke reduction

Positioning characteristics with end position controller SPC11						
Piston Ø			32	40	50	63
Repetition accuracy of a mid-position ¹⁾		[mm]	±2			
Assembly position			Horizontal			
Minimum load, horizontal ²⁾		[kg]	3	5	8	12
Maximum load, horizontal ²⁾		[kg]	45	75	120	180
Travel time			→ Software Tool "SoftStop": www.festo.com/en/engineering			
Recommended proportional directional control valve			→ 5 / 1.1-21			

- 1) In the stroke range from 100 ... 500 mm
- 2) Load = effective load + mass of all moving parts on the drive

Electrical data, displacement encoder		
Linearity error ¹⁾	[mm]	±(0.07±0.02xL)
Max. speed of travel	[m/s]	1.5
Ambient temperature	[°C]	-20 ... +80
Max. temperature coefficient	[ppm/°K]	30
Protection class		IP65
CE symbol (declaration of conformance)		In accordance with EU EMC Directive
Max. permitted magnetic disruption field at 100 mm interval from the sensor ²⁾	[kA/m]	10
Electrical connection		Cable with 8-pin plug, round type M12
Cable length	[m]	1.5

- 1) Maximum deviation of the output signal from "best fit" line (characteristic curve with nominal gradient).
L = Length of measuring system in meters
- 2) See also mounting conditions

Standard cylinders DNCI, with integrated displacement encoder

Technical data



Torques and lateral forces

The piston rod must not absorb any torque. We therefore recommend that an external guide FENG-KF be used with the drive DNCI. The guide unit is delivered installed.

The permissible static and dynamic characteristic load values with and without attached guide as well as with regard to the technical data of the variants (S2, S8, S9)

→ Volume 1 (standard cylinder DNC)

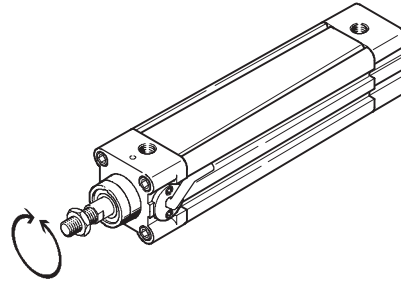

Mounting conditions

When mounting a drive A with magnet (for position sensing), in addition to a standard cylinder DNCI, the following conditions must be observed:

- X Minimum distance between the drives
- Y Offset between the drives on the bearing cap

Parallel assembly

If the offset $Y = 0$ mm, the drives can be assembled directly next to one another.

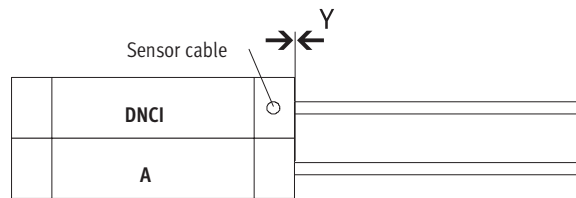

Offset assembly, cable outlet between the drives

If the offset $Y > 0$ mm and the cable outlet is between the drives, the distance from $X > 70$ mm must be observed.

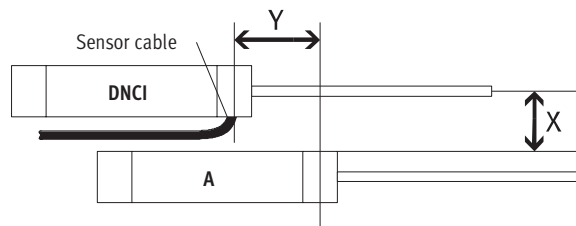

Offset assembly, cable outlet upwards or downwards

If the offset $Y > 0$ mm and the cable outlet is up or down, the distance from $X > 60$ mm must be observed.

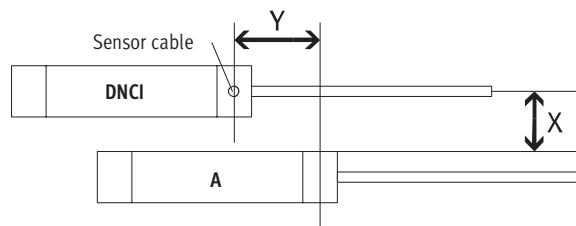

Pin assignment of plug, view of plug

Pin	Function	Colour
1	5 V	black
2	GND	brown
3	sin+	red
4	sin-	orange
5	cos-	green
6	cos+	yellow
7	Screening	Screening
8	-	-

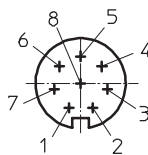

Standard cylinders DNCI, with integrated displacement encoder

Technical data



Servopneumatic positioning systems
 Cylinders with displacement encoders
1.1

Dimensions

Download CAD data → www.festo.com/en/engineering

Basic version

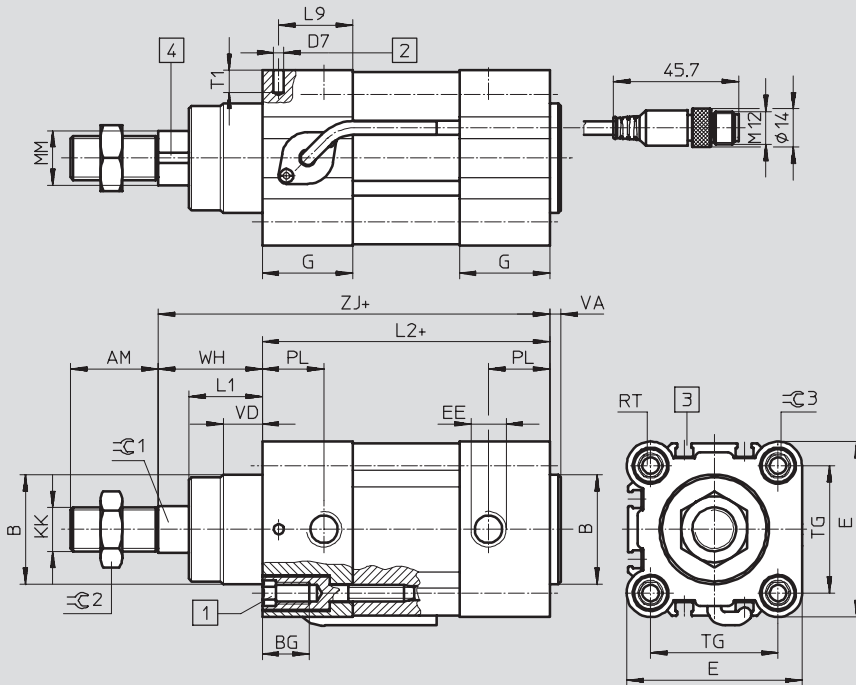

- 1 Socket head screw with female thread for mounting attachments
 - 2 Hole for securing the earthing self-tapping M4 screw according to DIN 7500
 - 3 Sensor slot for proximity sensor SME/SMT-8
 - 4 Magnetic measuring band
- + = plus stroke length
 ++ = plus 2x stroke length

S2 – Through piston rod

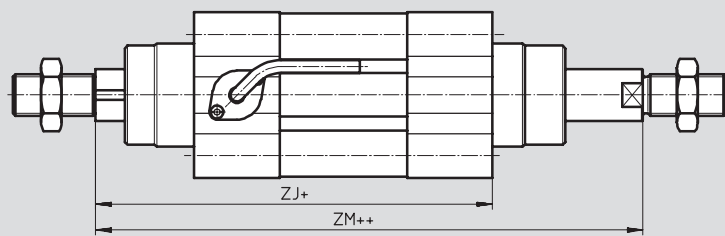

- + = plus stroke length
 ++ = plus 2x stroke length

S2 / KP – Through piston rod with clamping cartridge

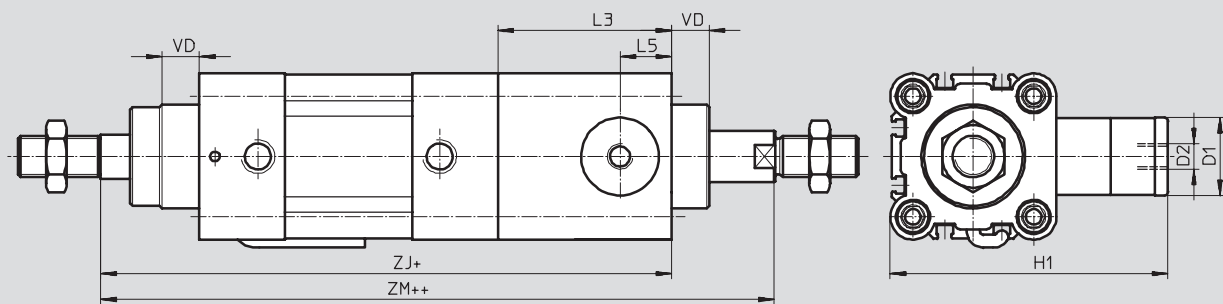

K8 – Extended piston rod

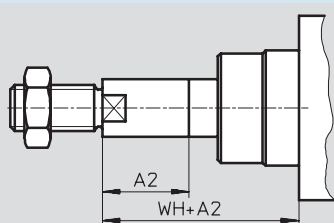

Standard cylinders DNCl, with integrated displacement encoder

FESTO

Technical data

∅ [mm]	AM	A2 max.	B ∅ d11	BG	D1 ∅ f9	D2	D7 ∅	E	EE	G	H1
32	22	500	30	16	20	M5	3.7	45	G $\frac{1}{8}$	28	67
40	24	500	35	16	24	G $\frac{1}{8}$	3.7	54	G $\frac{1}{4}$	33	88
50	32	500	40	17	30	G $\frac{1}{8}$	3.7	64	G $\frac{1}{4}$	33	107
63	32	500	45	17	38	G $\frac{1}{8}$	3.7	75	G $\frac{3}{8}$	40.5	123

∅ [mm]	KK	L1	L2	L3	L5	L9	MM ∅ f8	PL	RT	T1	TG
32	M10x1.25	18	94	45	14	22.5	12	15.6	M6	8	32.5
40	M12x1.25	21.3	105	53	16	27	16	14	M6	8	38
50	M16x1.5	26.8	106	67	20	27	20	14	M8	8	46.5
63	M16x1.5	27	121	76	24	33	20	17	M8	8	56.5

∅ [mm]	PI	VD	WH	ZJ		ZM		≈C1	≈C2	≈C3
					KP		KP			
32	4	10	26	120	165	148	193	10	16	6
40	4	10.8	30	135	188	167	220	13	18	6
50	4	14.3	37	143	210	183	250	17	24	8
63	4	14.5	37	158	234	199	275	17	24	8

Servopneumatic positioning systems
Cylinders with displacement encoders

1.1

Standard cylinders DNCI, with integrated displacement encoder

Technical data



Servopneumatic positioning systems
Cylinders with displacement encoders

1.1

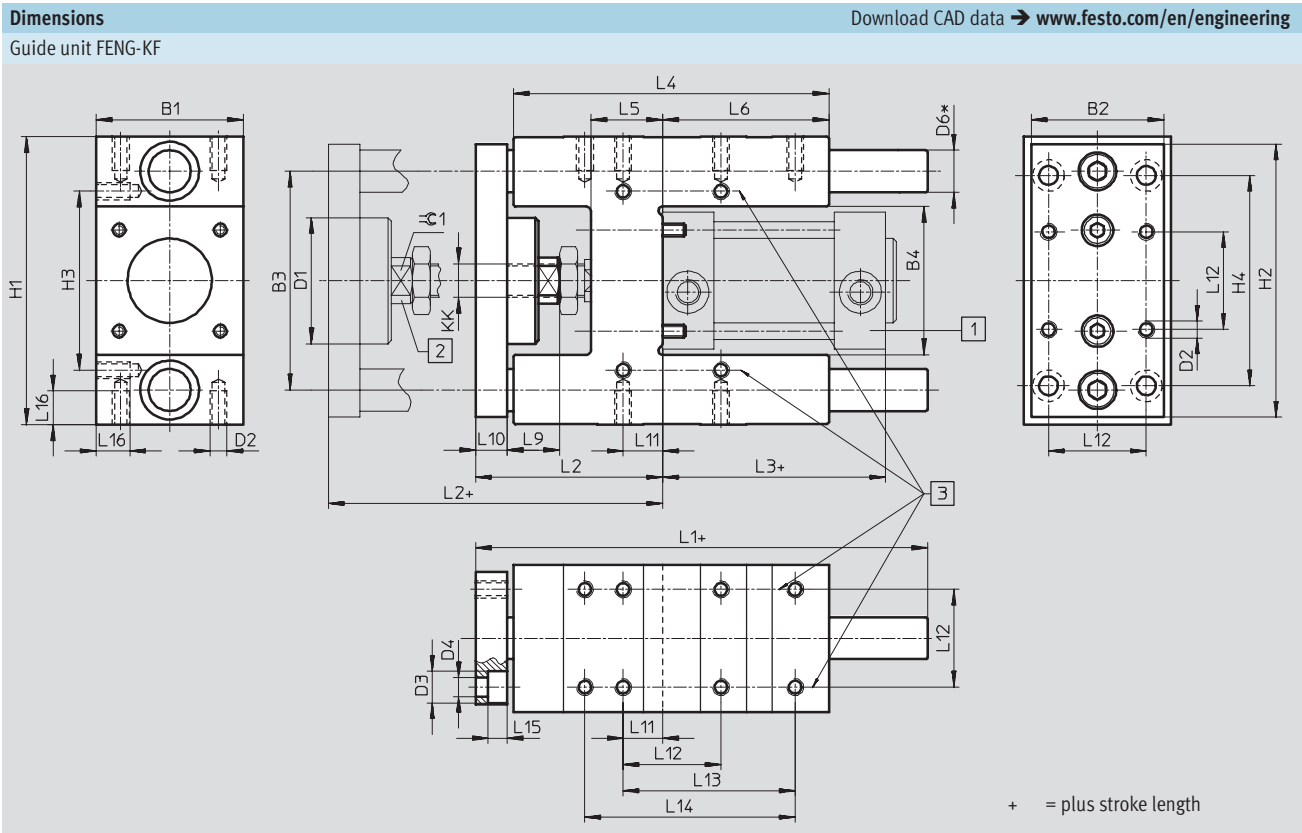

Standard cylinders DNCl, with integrated displacement encoder

FESTO

Technical data

For Ø	B1	B2	B3	B4	D1	D2	D3	D4	D6	H1
[mm]	-0.3		±0.2	±0.3	Ø		Ø	Ø	Ø	h6
32	50	45	74	50.5	44	M6	11	6.6	12	97 _{-0.4}
40	58	54	87	58.5	44	M6	11	6.6	16	115 _{-0.4}
50	70	63	104	70.5	60	M8	15	9	20	137 _{-0.5}
63	85	80	119	85.5	60	M8	15	9	20	152 _{-0.5}

For Ø	H2	H3	H4	KK	L1	L2	L3	L4	L5	L6
[mm]		±0.2	±0.2							
32	90	61	78	M10x1.25	155	67 ₊₅	94	125	24	76
40	110	69	84	M12x1.25	170	75 ₊₅	105	140	28	81
50	130	85	100	M16x1	188	89 ₊₁₀	106	150	34	79
63	145	100	105	M16x1	220	89 ₊₁₀	121	182	34	111

For Ø	L9	L10	L11	L12	L13	L14	L15	L16	≈G1
[mm]				±0.2	±0.2	±0.2			
32	20	12	4.3	32.5	70.3	78	6.5	12	15
40	22	12	11	38	84	–	6.5	14	15
50	25	15	18.8	46.5	81.8	100	9	16	19
63	25	15	15.3	56.5	105	–	9	16	19

Standard cylinders DNCI, with integrated displacement encoder

Ordering data – Modular products



M Mandatory data →

Module No.	Function	Piston Ø	Stroke	Cushioning	Position sensing
535 411	DNCI	32	10 ... 2,000	P	A
535 412		40			
535 413		50			
535 414		63			
Order example					
535 411	DNCI	- 32	- 100	- P	- A

Ordering table							
Piston Ø	32	40	50	63	Condi- tions	Code	Enter code
M Module No.	535 411	535 412	535 413	535 414			
Function	Standard cylinder with integrated displacement encoder, non-rotating piston rod					DNCI	DNCI
Piston Ø [mm]	32	40	50	63		-...	
Stroke [mm]	10 ... 2,000				1	-...	
Cushioning	Flexible cushioning rings/pads at both ends					-P	-P
Position sensing	For proximity sensing					-A	-A

1 **Stroke** Can only be used as a positioning drive without reservation in the range from 100 ... 500 mm

Transfer order code

Standard cylinders DNCI, with integrated displacement encoder

Ordering data – Modular products

0 Options

Type of piston rod	Piston rod extended at front	Clamping unit	Guide	Measuring head
S2	...K8	KP	FENG	MS
-	-	-	-	-

Ordering table							
Piston Ø	32	40	50	63	Condi- tions	Code	Enter code
0 Type of piston rod	Through piston rod					-S2	
Piston rod extended [mm]	1 ... 500				2	-...K8	
Clamping unit	Clamping cartridge				3	-KP	
Guide	Guide unit with ball bearing guide on the sensor head side				4	-FENG	
Measuring head	No measuring head					-MS	

- 2 **K8** In combination with piston rod type S2, the piston rod is only extended at the front (the side facing the measuring head)
- 3 **K9** Only with piston rod type S2
- 4 **FENG** Maximum stroke length 500 mm

Transfer order code

- [] - [] - [] - [] - [] - []

Standard cylinders DNCI, with integrated displacement encoder

Accessories



Foot mounting HNC

Material:
galvanised steel
Free of copper, PTFE and silicone

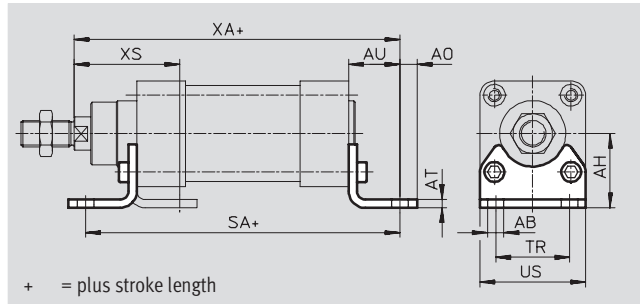

Dimensions and ordering data							
For Ø [mm]	AB Ø	AH	AO	AT	AU	SA	
						Basic cylinder	KP
32	7	32	6.5	5	24	142	187
40	10	36	9	5	28	161	214
50	10	45	10.5	6	32	170	237
63	10	50	12.5	6	32	185	261

For Ø [mm]	TR	US	XA		XS	CRC ¹⁾	Weights [g]	Part No.	Type
			Basic cylinder	KP					
32	32	45	144	189	45	2	135	174 369	HNC-32
40	36	54	163	216	53	2	180	174 370	HNC-40
50	45	64	175	242	62	2	325	174 371	HNC-50
63	50	75	190	266	63	2	405	174 372	HNC-63

1) Corrosion resistance class 2 according to Festo standard 940 070
Components requiring moderate corrosion resistance. Externally visible parts with primarily decorative surface requirements which are in direct contact with a normal industrial environment or media such as coolants or lubricating agents

Standard cylinders DNCI, with integrated displacement encoder



Accessories

Flange mounting FNC

Material:
FNC: galvanised steel
Free of copper, PTFE and silicone

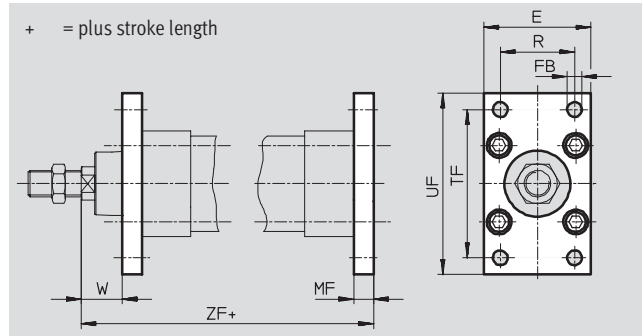

Dimensions and ordering data													
For Ø [mm]	E	TC Ø H13	MF	R	TF	UF	W	ZF		CRC ¹⁾	Weights [g]	Part No.	Type
								Basic cylinder	KP				
32	45	7	10	32	64	80	16	130	175	2	240	174 376	FNC-32
40	54	9	10	36	72	90	20	145	198	2	280	174 377	FNC-40
50	65	9	12	45	90	110	25	155	222	2	520	174 378	FNC-50
63	75	9	12	50	100	120	25	170	246	2	690	174 379	FNC-63

1) Corrosion resistance class 2 according to Festo standard 940 070
Components requiring moderate corrosion resistance. Externally visible parts with primarily decorative surface requirements which are in direct contact with a normal industrial environment or media such as coolants or lubricating agents

Rod eye SGS

Scope of delivery:
1 rod eye, 1 hex nut to DIN 439

Material:
galvanised steel

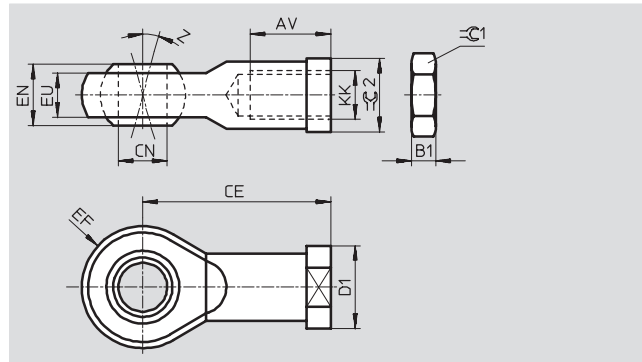

Dimensions and ordering data														
For Ø [mm]	AV	B1	CE	CN Ø H7	D1 Ø	EF ±0.5	EN	Z [°]	≈C1	≈C2	CRC ¹⁾	Weights [g]	Part No.	Type
M12x1.25	22 -2	6	50	12	22	16	16	13	19	19	2	105	9 262	SGS-M12x1,25
M16x1.5	28 -2	8	64	16	27	21	21	15	24	22	2	210	9 263	SGS-M16x1,5

1) Corrosion resistance class 2 according to Festo standard 940 070
Components requiring moderate corrosion resistance. Externally visible parts with primarily decorative surface requirements which are in direct contact with a normal industrial environment or media such as coolants or lubricating agents

Standard cylinders DNCI, with integrated displacement encoder

Accessories



Trunnion mounting kit ZNCM

The mounting kit can be attached at any position along the profile barrel of a cylinder.

Material:
tempered steel

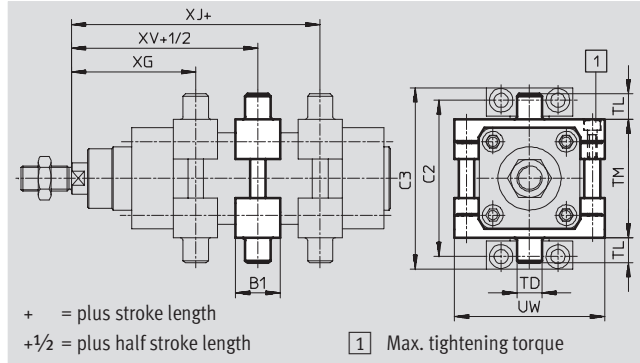

Dimensions and ordering data									
For \varnothing	B1	C2	C3	TD	TL	TM	UW	XG	
[mm]				\varnothing e9				Basic cylinder	KP
32	30	71	86	12	12	50	65	66.1	111.1
40	32	87	105	16	16	63	75	75.6	128.6
50	34	99	117	16	16	75	95	83.6	150.6
63	41	116	136	20	20	90	105	93.1	169.1

For \varnothing	XJ		XV		Max. tightening torque	CRC ¹⁾	Weights	Part No.	Type
	Basic cylinder	KP	Basic cylinder	KP					
[mm]					[Nm]		[g]		
32	79.9	124.9	73	118	4+1	2	210	163 525	ZNCM-32
40	89.4	142.4	82.5	135.5	8+1	2	385	163 526	ZNCM-40
50	96.4	163.4	90	157	8+2	2	595	163 527	ZNCM-50
63	101.9	177.9	97.5	173.5	18+2	2	890	163 528	ZNCM-63

1) Corrosion resistance class 2 according to Festo standard 940 070
Components requiring moderate corrosion resistance. Externally visible parts with primarily decorative surface requirements which are in direct contact with a normal industrial environment or media such as coolants or lubricating agents

Trunnion supports LNZG

Material:
Trunnion support:
Anodised aluminium
Plain bearing: Plastic

Free of copper, PTFE and silicone

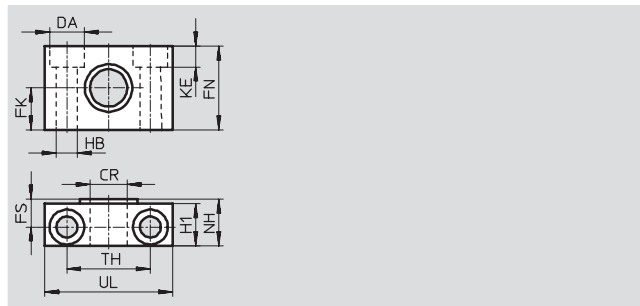

Dimensions and ordering data															
For \varnothing	CR	DA	FK	FN	FS	H1	HB	KE	NH	TH	UL	CRC ¹⁾	Weights	Part No.	Type
[mm]	\varnothing D11	\varnothing H13	\varnothing ± 0.1				\varnothing H13			± 0.2			[g]		
32	12	11	15	30	10.5	15	6.6	6.8	18	32	46	2	125	32 959	LNZG-32
40, 50	16	15	18	36	12	18	9	9	21	36	55	2	400	32 960	LNZG-40/50
63	20	18	20	40	13	20	11	11	23	42	65	2	480	32 961	LNZG-63/80

1) Corrosion resistance class 2 according to Festo standard 940 070
Components requiring moderate corrosion resistance. Externally visible parts with primarily decorative surface requirements which are in direct contact with a normal industrial environment or media such as coolants or lubricating agents

Standard cylinders DNCl, with integrated displacement encoder

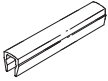

Accessories

Ordering data					
	For Ø	Remarks	Part No.	Type	PU ¹⁾
Push-in fitting Technical data → Volume 3					
	32	-	186 098	QS-G$\frac{1}{8}$-8	10
	40		186 099	QS-G$\frac{1}{4}$-8	10
	50		186 101	QS-G$\frac{1}{4}$-10	10
	63		186 100	QS-G$\frac{3}{8}$-8	10
			186 102	QS-G$\frac{3}{8}$-10	10
Slot cover Technical data → Volume 1					
	32, 40, 50, 63	every 0.5 m	151 680	ABP-5-S	2

1) Packaging unit quantity

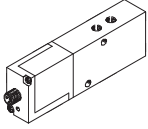
Ordering data – Proportional directional control valve				Technical data → 5 / 1.5-2	
	For Ø [mm]	Stroke [mm]	Part No.	Type	
	For applications with axis controller SPC200				
	32	50 ... 150	154 200	MPYE-5-M5-010-B	
		150 ... 400	151 692	MPYE-5-$\frac{1}{8}$-LF-010-B	
		> 400	151 693	MPYE-5-$\frac{1}{8}$-HF-010-B	
	40	50 ... 300	151 692	MPYE-5-$\frac{1}{8}$-LF-010-B	
		> 300	151 693	MPYE-5-$\frac{1}{8}$-HF-010-B	
	50	50 ... 200	151 692	MPYE-5-$\frac{1}{8}$-LF-010-B	
		200 ... 900	151 693	MPYE-5-$\frac{1}{8}$-HF-010-B	
		> 900	151 694	MPYE-5-$\frac{1}{4}$-010-B	
	63	50 ... 300	151 693	MPYE-5-$\frac{1}{8}$-HF-010-B	
		300 ... 1,000	151 694	MPYE-5-$\frac{1}{4}$-010-B	
		> 1,000	151 695	MPYE-5-$\frac{3}{8}$-010-B	
	For applications with Soft Stop end position controller SPC11				
	32	100 ... 500	151 692	MPYE-5-$\frac{1}{8}$-LF-010-B	
		> 500	151 693	MPYE-5-$\frac{1}{8}$-HF-010-B	
	40	100 ... 320	151 692	MPYE-5-$\frac{1}{8}$-LF-010-B	
		320 ... 500	151 693	MPYE-5-$\frac{1}{8}$-HF-010-B	
		> 500	151 694	MPYE-5-$\frac{1}{4}$-010-B	
	50	100 ... 250	151 692	MPYE-5-$\frac{1}{8}$-LF-010-B	
		250 ... 400	151 693	MPYE-5-$\frac{1}{8}$-HF-010-B	
> 500		151 694	MPYE-5-$\frac{1}{4}$-010-B		
63	100 ... 200	151 692	MPYE-5-$\frac{1}{8}$-LF-010-B		
	200 ... 400	151 693	MPYE-5-$\frac{1}{8}$-HF-010-B		
	400 ... 650	151 694	MPYE-5-$\frac{1}{4}$-010-B		
	> 650	151 695	MPYE-5-$\frac{3}{8}$-010-B		

 Note
 Recommended proximity sensor
 → Standard cylinder DNC, Volume 1

Standard cylinder DNCM, external displacement encoder

Key features

Individual positioning components with standard cylinder DNCM ...

Servopneumatic positioning systems
Cylinders with displacement encoders

1.1



Proportional directional control valve
MPYE-...
→ 5 / 1.5-2



Soft Stop → 5 / 1.4-2

Positioning technology → 5 / 1.3-2

End position controller
SPC11-POT-TLF



Axis interface
SPC-AIF-POT



Axis positioning controller
SPC200



Standard cylinder DNCM, external displacement encoder

Type code

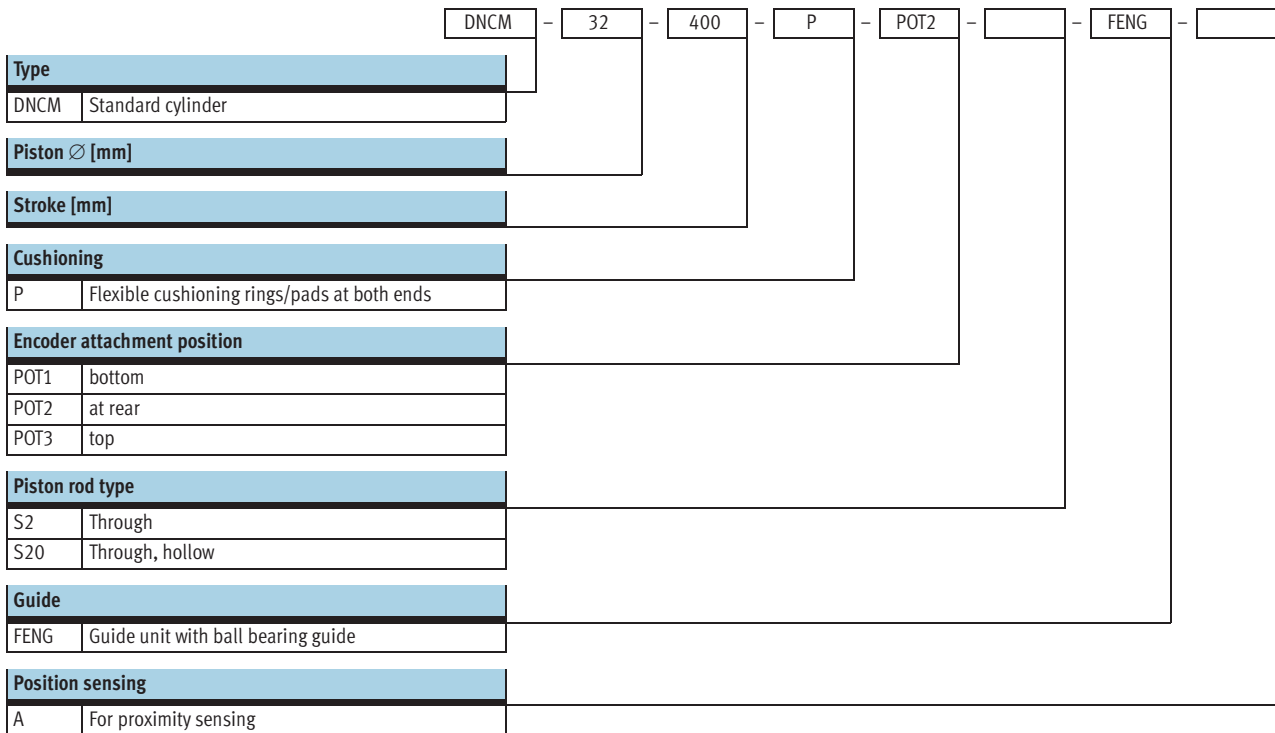

Standard cylinder DNCM, external displacement encoder

Peripherals overview

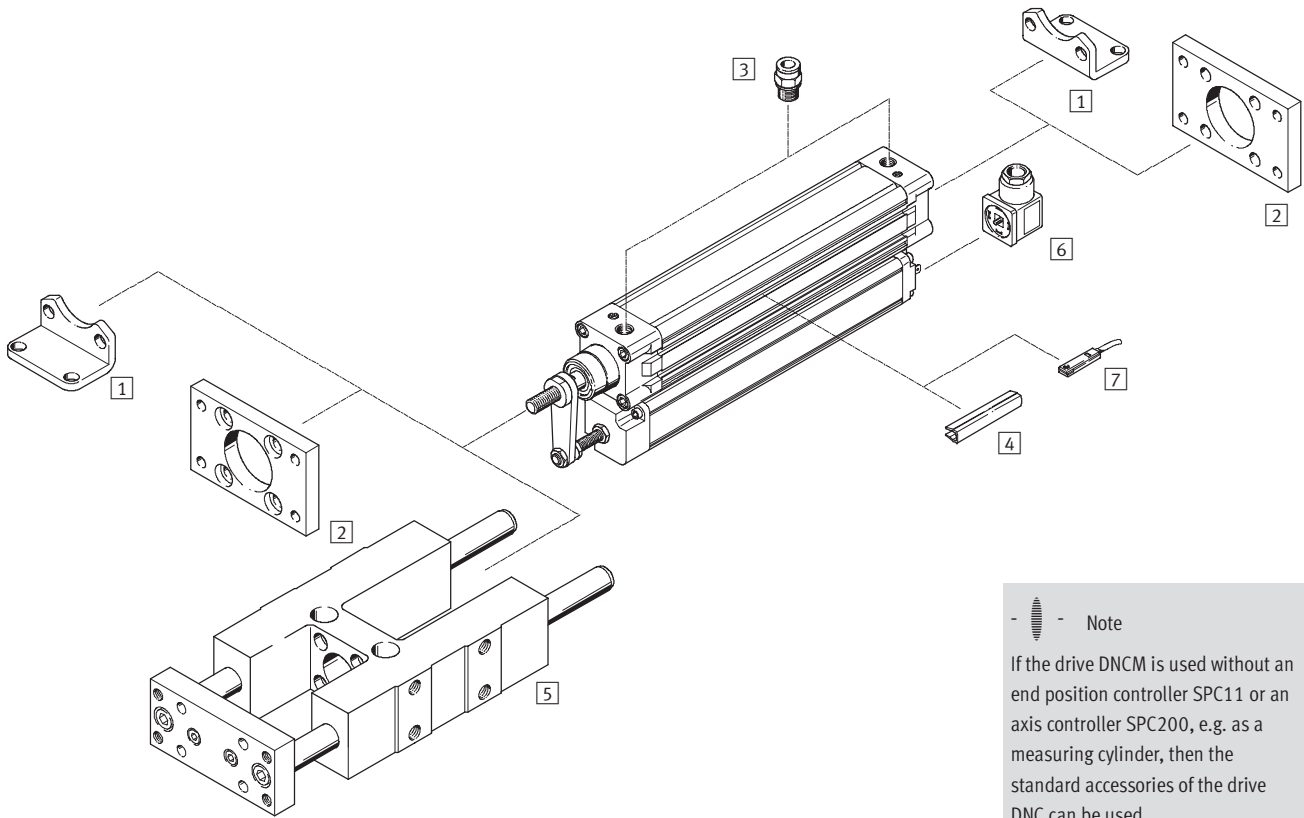

 Note

If the drive DNCM is used without an end position controller SPC11 or an axis controller SPC200, e.g. as a measuring cylinder, then the standard accessories of the drive DNC can be used.

Standard cylinder DNCM, external displacement encoder

Peripherals overview

Accessories		
Type	Brief description	→ Page
1) Foot mounting HNC	to mount the drive on the bearing and end cap	5 / 1.1-36
2) Flange mounting FNC	to mount the drive on the bearing and end cap	5 / 1.1-36
3) Push-in fitting QS	for connecting compressed air tubing with standard O.D.	5 / 1.1-37
4) Slot cover ABP-5-S	to protect against the ingress of dirt	5 / 1.1-36
5) Guide unit ¹⁾ FENG-KF	to protect against torsion at high torque loads	5 / 1.1-36
6) Plug socket MSSD-C-4P	to connect the displacement encoder, is part of the end position controller SPC11 and the axis controller SPC200	5 / 1.1-37
7) Proximity sensors SME-/SMT-8	for additional sensing of the piston position, can be ordered optionally, only in conjunction with the order code A in the drive's modular product section.	Volume 1

1) FENG-KF must be attached to the piston rod such that backlash is excluded.



Standard cylinder DNCM, external displacement encoder

Technical data

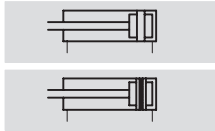

Function



-  Diameter
32 mm and 50 mm
-  Stroke length
100 ... 500 mm



General technical data		
Piston \varnothing	32	50
Design	Piston	
	Piston rod	
	Profile barrel	
Mode of operation	Double-acting	
Operating medium ¹⁾	Compressed air, filtered and unlubricated, filter unit 5 μ m	
Cushioning	Flexible cushioning rings/pads at both ends	
Position sensing	Displacement encoder, attached externally	
	Proximity sensor ²⁾	
Measuring principle (displacement encoder)	Analogue with encoder, contacting and absolute measurement	
Type of mounting	Foot mounting	
Stroke ³⁾	[mm]	100, 160, 200, 250, 320, 400, 500
Torsion protection/Guide ⁴⁾	Guide rod with yoke, with ball bearing guide	
Stroke	[mm]	100, 160, 200, 250
Pneumatic connection	G1/8	G1/4
Electrical connection	4-pin plug, type A DIN 43 650	

- 1) The proportional directional control valve MPYE used requires the characteristic values.
- 2) Not included in the scope of delivery, can be ordered as an option.
- 3) Note stroke reduction in conjunction with SPC200.
- 4) FENG-KF guide must be ordered as an option and will be supplied attached, the max. stroke is reduced.

Forces [N] and impact energy [Nm]		
Piston \varnothing	32	50
Theoretical force at 6 bar advancing	483	1,178
Theoretical force at 6 bar retracting	415	990
Max. impact energy at end positions	0.1	0.2

Permissible impact velocity:

$$v_{perm.} = \sqrt{\frac{2 \times E_{perm.}}{m_{dead} + m_{load}}}$$

Maximum permissible load:

$$m_{load} = \frac{2 \times E_{perm.}}{v^2} - m_{dead}$$

 **Note**

This data represents the maximum values which can be achieved. Values fluctuate in practice relative to the size of the effective load. Allowance must also be made for the limits of the cushioning capacity of the drive and the permissible impact energy.

Standard cylinder DNCM, external displacement encoder

Technical data

Positioning characteristics with axis controller SPC200			
Piston Ø		32	50
Repetition accuracy	horizontal	[mm]	±0.2
	vertical	[mm]	±0.2 (for stroke 0 ... 200 mm)
		[mm]	±0.4 (for stroke 200 ... 500 mm)
Mounting position		Any	
Minimum load, horizontal ¹⁾		[kg]	3
Maximum load, horizontal ¹⁾⁶⁾		[kg]	45
Minimum load, vertical ¹⁾		[kg]	3
Maximum load, vertical ¹⁾⁶⁾		[kg]	15
Min. speed of travel		[m/s]	0.05
Max. speed of travel		[m/s]	2.2
Typ. positioning time, long stroke ²⁾		[s]	0.45/0.75
Typ. positioning time, short stroke ³⁾		[s]	0.35/0.55
Minimum positioning stroke ⁴⁾		[mm]	3
Stroke reduction ⁵⁾		[mm]	≥ 10
Recommended proportional directional control valve		→ 5 / 1.1-37	

- 1) Load = effective load + mass of all moving parts on the drive
- 2) At 6 bar, horizontal mounting position, DNCM-XX-500, 400 mm positioning travel at min./max. load
- 3) At 6 bar, horizontal mounting position, DNCM-XX-500, 100 mm positioning travel at min./max. load
- 4) In relation to the maximum stroke of the drive, but never more than 20 mm.
- 5) The stroke reserve is to be maintained on every side of the drive, the max. positionable stroke is therefore: Stroke – 2x stroke reserve
- 6) With external guide

Positioning characteristics with Soft Stop end position controller SPC11			
Piston Ø		32	50
Repetition accuracy of a mid-position ¹⁾		[mm]	±2
Mounting position		horizontal	
Minimum load, horizontal ²⁾		[kg]	3
Maximum load, horizontal ²⁾		[kg]	45
Travel time		→ Software Tool "SoftStop": www.festo.com/en/engineering	
Recommended proportional directional control valve		→ 5 / 1.1-37	

- 1) In the stroke range from 100 ... 500 mm
- 2) Load = effective load + mass of all moving parts on the drive

Operating and environmental conditions			
Piston Ø		32	50
Operating pressure ¹⁾		[bar]	4 ... 8
Ambient temperature ²⁾		[°C]	-10 ... +80
Vibration resistance		To DIN/IEC 68 Parts 2 -6, severity level 2	
Continuous shock resistance		To DIN/IEC 68 Parts 2 -27, severity level 2	
CE marking symbol (see conformity declaration)		As per EU EMC directive	
Protection class (displacement encoder)		IP54 to IEC 60 529	
Corrosion resistance class CRC ³⁾		1	

- 1) Only applies for applications with the Soft Stop end position controller SPC11 and axis controller SPC200.
- 2) Note operating range of proximity sensors
- 3) Corrosion resistance class 1 according to Festo standard 940 070
Components requiring low corrosion resistance. Transport and storage protection.

Weights [g] with displacement encoder								
Piston Ø		Stroke						
		100	160	200	250	320	400	500
32	Product weight	1,160	1,406	1,640	1,990	2,312	2,640	3,190
	Moving load	310	375	430	490	565	660	760
50	Product weight	2,270	2,684	3,030	3,520	4,038	4,590	5,420
	Moving load	850	1,010	1,125	1,265	1,455	1,675	1,935

Standard cylinder DNCM, external displacement encoder

Technical data

Electrical data, displacement encoder			100	160	200	250	320	400	500
Stroke									
Power supply ¹⁾	[V DC]		10						
Max. current consumption	[mA]		4						
Wiper current	recommended	[µA]	< 1						
	maximum ²⁾	[mA]	10						
Connection resistance	[kΩ]		3	5					
Connection resistance tolerance	[%]		±20						
Resolution	[mm]		≤ 0.01						
Independent linearity	maximum	[%]	0.09	0.08	0.07	0.06	0.05	0.05	0.05
Temperature coefficient	[ppm/°K]		≤ 5						
Interface			Analogue						

- 1) Stabilised power supply is recommended, max. 42 VDC permissible.
2) Only permissible in the short-term in the event of a fault.

Materials

Sectional view

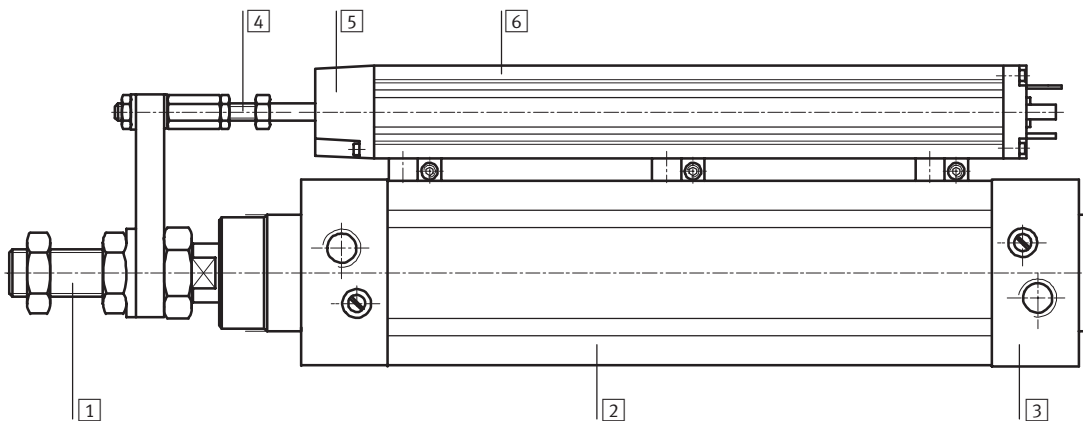



Drive			
1	Piston rod	High-alloy steel	
2	Cylinder barrel	Anodised aluminium	
3	Bearing/end caps	Die-cast aluminium	
-	Dynamic seals	Polyurethane TPE-U	
-	Static seals	Nitrile rubber	
-	Lubricant	Klüberplex BE31-102	
Displacement encoder			
4	Connecting rod	High-alloy steel	
5	Bearing cap	Reinforced polyester	
6	Profile	Anodised aluminium	
-	Resistor element	Conductive plastic	
-	Wiper	Contact	Precious metal
		Silencer	Elastomer
-	Cover seal	Nitrile rubber	
-	Rod seal	Tetrafluoroethylene	
-	Lubricant	ISOFLEX Topas MB52	

Standard cylinder DNCM, external displacement encoder

Technical data

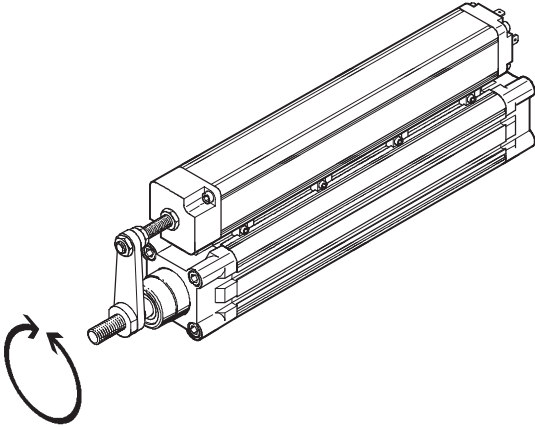
Torques and lateral forces



 - Note

Torques or lateral forces can result in inaccurate measurement results. We therefore recommend that an external guide be used with the drive DNCM.

This must be attached to the piston rod such that backlash is excluded.

Use of the DNCM with the FENG-KF is recommended. The drive is delivered with the guide attached.

The permissible static and dynamic characteristic load values with and without attached guide
 → Volume 1 (standard cylinder DNC)

Technical data for the S2 and S20 designs of the piston rod
 → Volume 1 (standard cylinder DNC)

Standard cylinder DNCM, external displacement encoder

Technical data

Dimensions

Download CAD data → www.festo.com/en/engineering

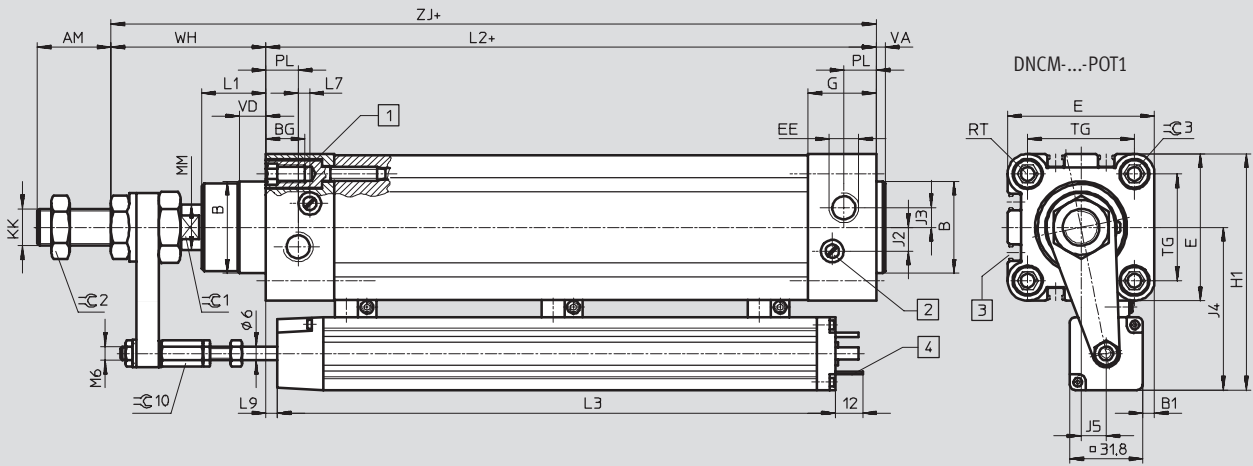

DNCM-...-POT2

DNCM-...-POT3

DNCM-...-S2/DNCM-...-S20

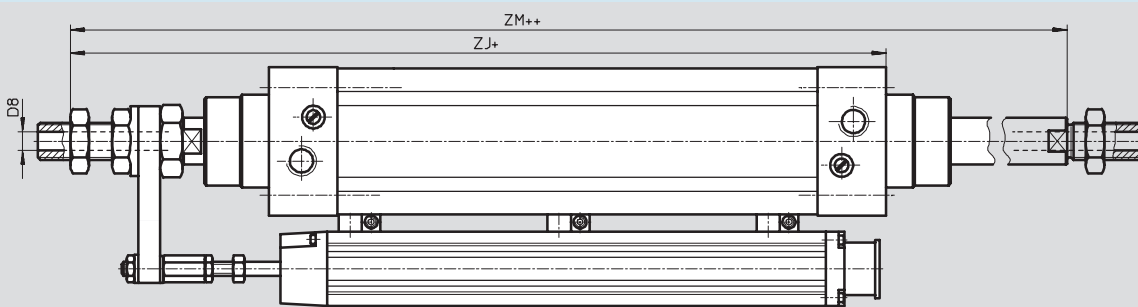

- 1 Socket head screw with female thread for mounting attachments
- 2 Regulating screw for adjustable end-position cushioning

- 3 Sensor slot for proximity sensor SME/SMT-8
- 4 Plug connector to DIN 43 650-A

+ = plus stroke length
++ = plus 2x stroke length

Standard cylinder DNCM, external displacement encoder

Technical data

∅	AM	B ∅ d11	BG	B1 ±0.8	D8 ∅	E	EE	G	H1 ±1.5
[mm]									
32	22	30	16	0.24	4.5	45	G1/8	25.1	84.4
50	32	40	17	5.6	8	64	G1/4	29.6	103.4

∅	J2	J3	J4 ±1	J5 ±1	KK	L1	L2
[mm]							
32	6	5.2	45.8	6.3	M10x1.25	18	94
50	10.4	8.5	55.3	10.6	M16x1.5	28	106

∅	Stroke [mm]	L3	L7	L9	MM ∅ f8	PL	RT	TG	VA	VD
[mm]	[mm]									
32	100	201	3.3	6.5 ±2	12	15.6	M6	32.5	4	10
	160	248		1 +2/-1						
	200	298		5 ±2						
	250	349		5.5 ±2						
	320	436		13 ±2						
	400	502		6 ±2						
	500	629		20 ±2						
50	100	201	5.1	6.5 ±2	20	14	M8	46.5	4	11.5
	160	248		1 +2/-1						
	200	298		5 ±2						
	250	349		5.5 ±2						
	320	436		13 ±2						
	400	502		6 ±2						
	500	629		0 ±2						

∅	WH	ZJ	ZM	≈C1	≈C2	≈C3
[mm]						
32	44.4	138.4	166.4	10	16	6
50	67.4	173.4	213.4	17	24	8

Standard cylinder DNCM, external displacement encoder

Technical data

Dimensions

Download CAD data → www.festo.com/en/engineering

Guide unit FENG-KF

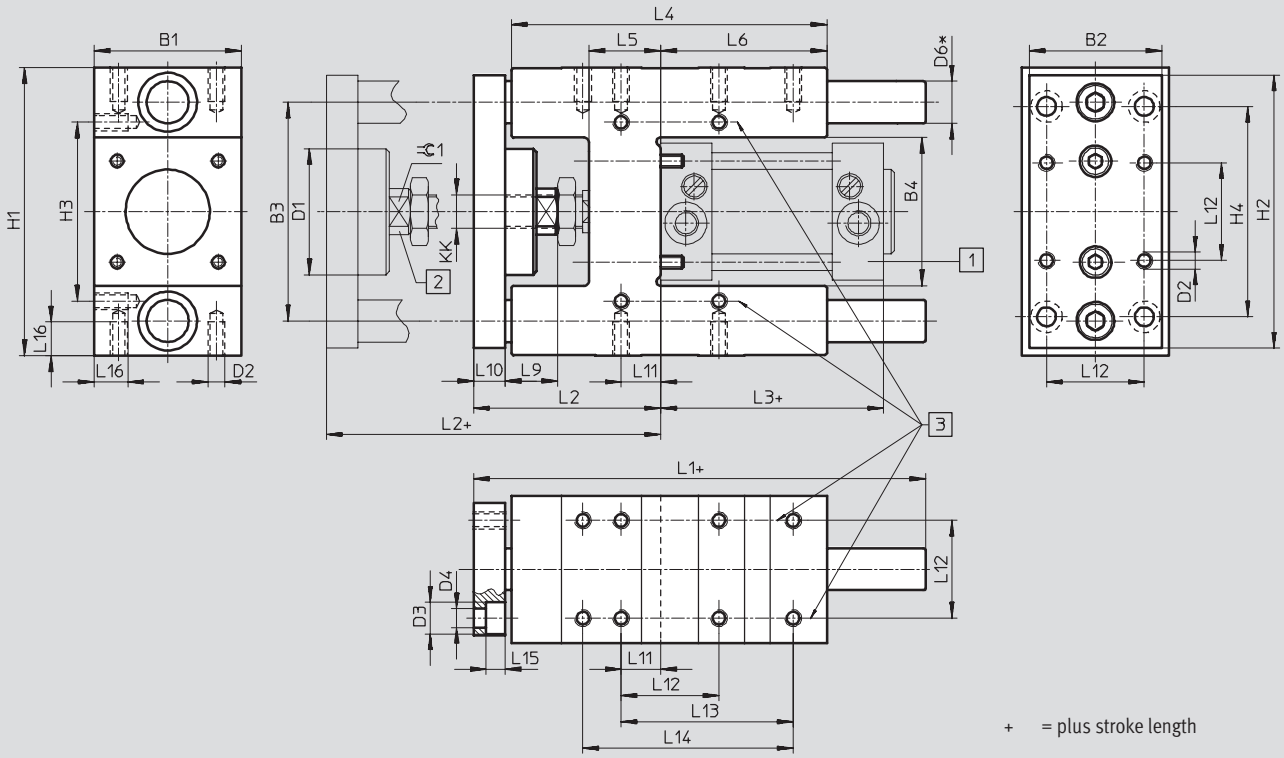

Servopneumatic positioning systems
Cylinders with displacement encoders

1.1

Standard cylinder DNCM, external displacement encoder

Technical data

for \varnothing	B1	B2	B3	B4	D1 \varnothing	D2	D3 \varnothing	D4 \varnothing
[mm]	-0.3		± 0.2	± 0.3				
32	50	45	74	50.5	44	M6	11	6.6
50	70	63	104	70.5	60	M8	15	9

for \varnothing	D6 \varnothing	H1	H2	H3	H4	KK	L1	L2
[mm]	h6			± 0.2	± 0.2			
32	12	97 _{-0.4}	90	61	78	M10x1.25	155	67 ₊₅
50	20	137 _{-0.5}	130	85	100	M16x1.5	188	89 ₊₁₀

for \varnothing	L3	L4	L5	L6	L9	L10	L11	L12
[mm]								± 0.2
32	94	125	24	76	20	12	4.3	32.5
50	106	150	34	79	25	15	18.8	46.5

for \varnothing	L13	L14	L15	L16	$\approx \varnothing 1$	Stroke	Weight per 10 mm stroke	Weight
[mm]	± 0.2	± 0.2				[mm]	[g]	[g]
32	70.3	78	6.5	12	15	10 ... 500	18	1 530
50	81.8	100	9	16	19	10 ... 500	50	4 030

Standard cylinder DNCM, external displacement encoder

Ordering data – Modular product system



Arrangement of the displacement encoder

DNCM-...-POT1 (encoder underneath)

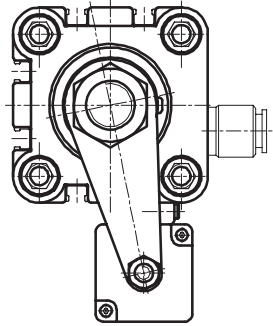

DNCM-...-POT2 (encoder at rear)

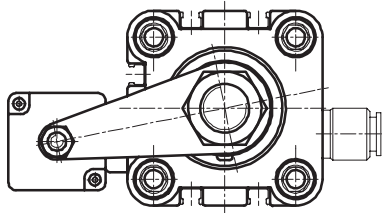

DNCM-...-POT3 (encoder on top)

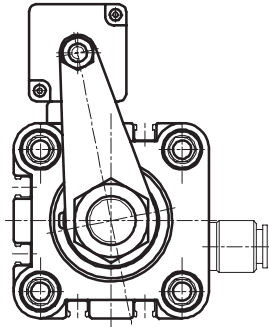

Standard cylinder DNCM, external displacement encoder

Ordering data – Modular product system

M Mandatory data						O Options			
Module No.	Basic function	Size	Stroke	Cushioning	Encoder attachment position	Piston rod type	Guide	Position sensing	
528 940	DNCM	32	100	P	POT1 POT2 POT3	S2 S20	FENG	A	
528 941		50	160						
			200						
			250						
			320						
			400						
			500						
Ordering example									
528 941	DNCM	- 50	- 500	- P	- POT3	- S20	-	- A	

Ordering table						
Size	32	50	Conditions	Code	Enter code	
M Module No.	528 940		528 941			
Basic function	Standard cylinder with displacement encoder				DNCM	DNCM
Size [mm]	32	50		-...		
Stroke [mm]	100			-100		
	160			-160		
	200			-200		
	250			-250		
	320		1	-320		
	400		1	-400		
	500		1	-500		
Cushioning	Flexible cushioning rings/plates at both ends				-P	-P
Encoder attachment position	Encoder underneath				-POT1	
	Encoder at rear				-POT2	
	Encoder on top				-POT3	
O Piston rod type	Through piston rod		1	-S2		
	Through, hollow piston rod		1	-S20		
Guide	Guide unit with ball bearing guide KF				2	-FENG
Position sensing	For proximity sensing					-A

1 320, 400, 500, S2, S20

Not with guide FENG.

2 FENG

Only with POT2 encoder. FENG is mounted without backlash.

Transfer order code

Standard cylinder DNCM, external displacement encoder

Accessories



Foot mounting HNC

Material:
Galvanised steel
Free of copper, PTFE and silicone

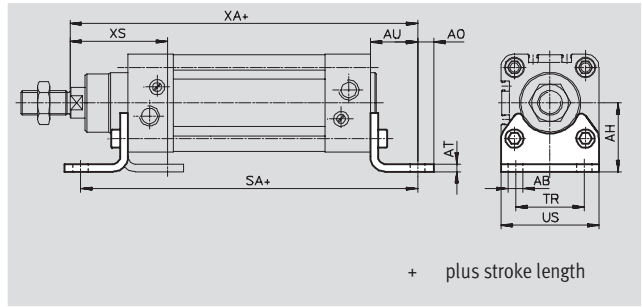

Dimensions and ordering data													
for \varnothing	AB	AH	AO	AT	AU	SA	TR	US	XA	XS	Weight	Part No.	Type
[mm]	\varnothing										[g]		
32	7	32	6.5	4	24	142	32	45	144	45	135	174 369	HNC-32
50	10	45	9.5	5	31	170	45	64	175	62	325	174 371	HNC-50

Flange mounting FNC

Material:
Galvanised steel
Free of copper, PTFE and silicone

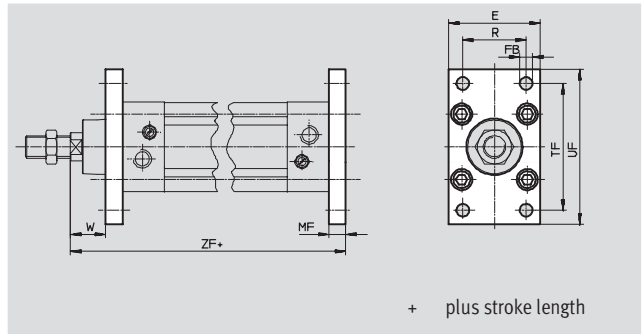

Dimensions and ordering data													
for \varnothing	E	FB	MF	R	TF	UF	W	ZF	Weight	Part No.	Type		
[mm]		\varnothing H13							[g]				
32	45	7	10	32	64	80	16	130	240	174 376	FNC-32		
50	65	9	12	45	90	110	25	155	520	174 378	FNC-50		

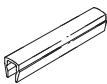
Ordering data – Slot cover				Technical data → Volume 1		
	for \varnothing	Remarks	Part No.	Type	PU ¹⁾	
	[mm]					
Slot cover ABP-S						
	32, 50	0.5 m each	151 680	ABP-5-S	2	

1) Packaging unit quantity

Standard cylinder DNCM, external displacement encoder

Accessories



Ordering data – Push-in/threaded fitting			Technical data → Volume 3		
	for Ø [mm]	Remarks	Part No.	Type	PU ¹⁾
	32	for connecting compressed air tubing with standard O.D.	186 098	QS-G$\frac{1}{8}$-8	10
	50		186 099	QS-G$\frac{1}{4}$-8	

1) Packaging unit quantity

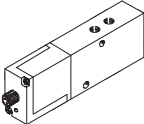
Ordering data – Proportional directional control valve			Technical data → 5 / 1.5-2		
	for Ø [mm]	Stroke [mm]	Part No.	Type	
	for applications with axis controller SPC200				
	32	100/160/200/250/320		151 692	MPYE-5-$\frac{1}{8}$-LF-010-B
		400/500		151 693	MPYE-5-$\frac{1}{8}$-HF-010-B
	50	100/160/200/250/320/400/500		151 693	MPYE-5-$\frac{1}{8}$-HF-010-B
	for applications with Soft Stop end position controller SPC11				
	32	100/160/200/250/320/400		151 692	MPYE-5-$\frac{1}{8}$-LF-010-B
		500		151 693	MPYE-5-$\frac{1}{8}$-HF-010-B
	50	100/160/200/250		151 692	MPYE-5-$\frac{1}{8}$-LF-010-B
		320/400		151 693	MPYE-5-$\frac{1}{8}$-HF-010-B
		500		151 694	MPYE-5-$\frac{1}{4}$-010-B

Ordering data – Plug socket

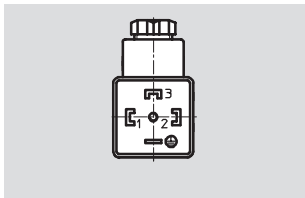

PIN	Pin allocations	Designation	Part No.	Type
1	Power supply	Plug socket	171 157	MSSD-C-4P
2	Signal			
3	0 V			
PE	PE (yellow), screen			

 Note
 Recommended proximity sensor
 → Drive DNC, Volume 1

Linear drives DGPL, external displacement encoder

Features



Individual positioning components with linear drive DGPL ...

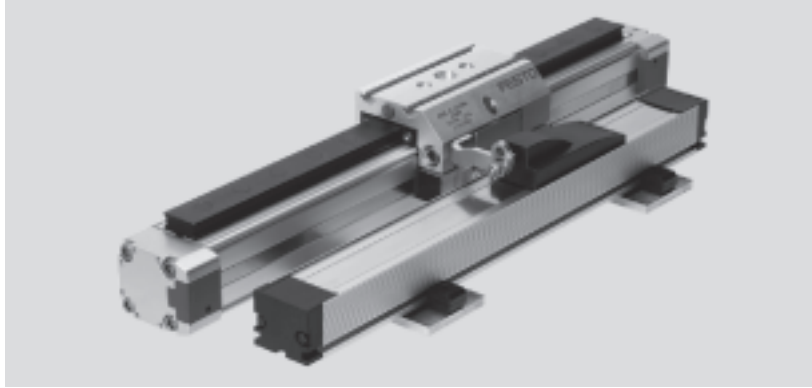

Proportional directional control valve
MPYE-...
→ 5 / 1.5-2



Soft Stop → 5 / 1.4-2

Positioning technology → 5 / 1.3-2

End position controller
SPC11-POT-TLF



Axis interface
SPC-AIF-POT



Axis positioning controller
SPC200



Linear drives DGPL, external displacement encoder

Features

DGPL, with recirculating ball bearing guide

- Piston \varnothing 25 ... 63 mm
- Stroke 225 ... 2,000 mm
- Standard slide or extended slide
- High characteristic load values
- Air connections on both sides



DGPL, with recirculating ball bearing guide and clamping unit

- Piston \varnothing 25...40 mm
- Stroke 225 ... 2,000 mm
- Standard slide or extended slide
- In the event of a loss of pressure, the slide can be fixed in vertical operation using the clamping unit.
- High characteristic load values
- Air connections on both sides



Linear drives DGPL, external displacement encoder

Peripherals overview

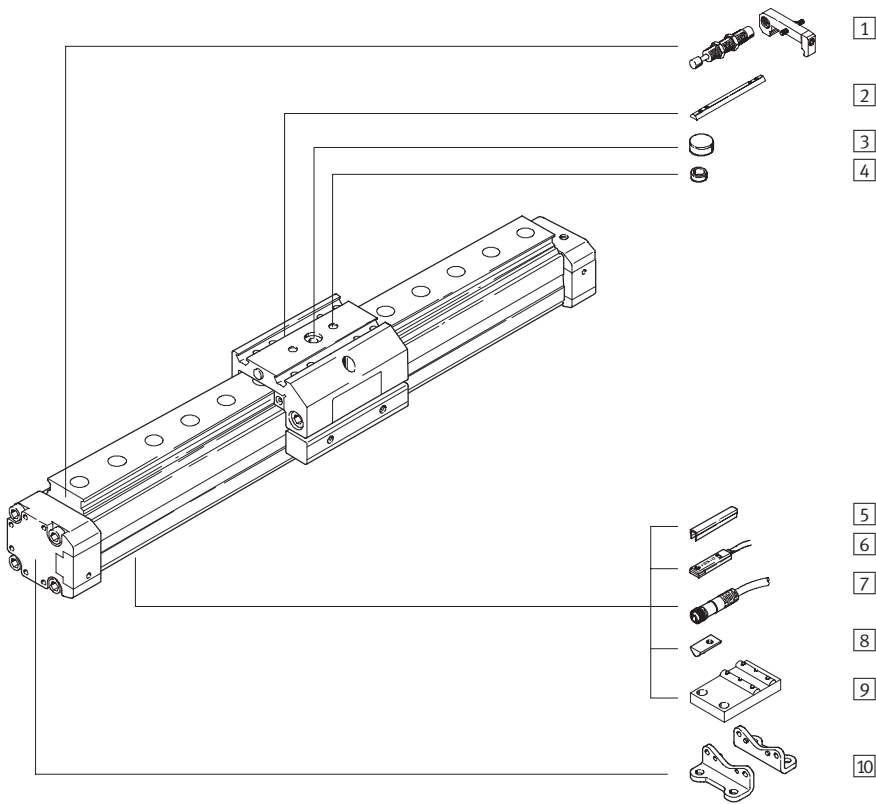

Displacement encoder attachment position 11

Slide at rear (SH)

Slide at front (SV)

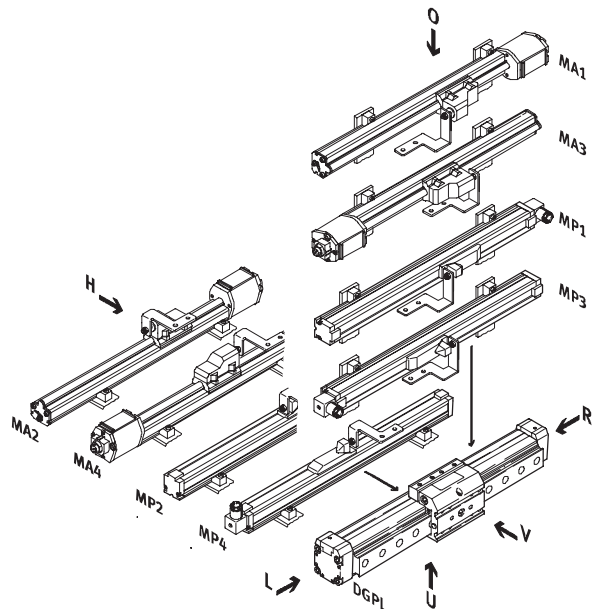
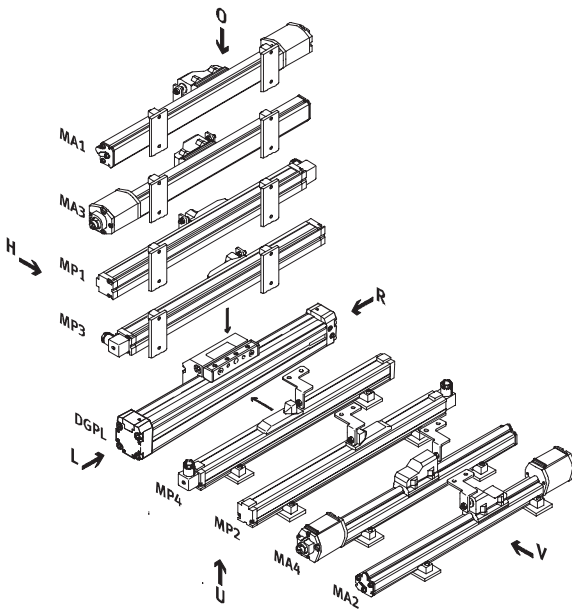

Linear drives DGPL, external displacement encoder

Peripherals overview

Variants and accessories		
Type	Brief description	→ Page
1 Shock absorber kits C	to avoid damage at the end stop, in the event of malfunctions	5 / 1.1-88
2 Slot nut for slide X	for mounting loads and attachments on the slide	5 / 1.1-89
3 Central mounting Q	for centring loads and attachments on the slide	5 / 1.1-89
4 Centring sleeves Z	for centring loads and attachments on the slide	5 / 1.1-89
5 Slot cover B/S	to protect against the ingress of dirt	5 / 1.1-89
6 Proximity sensors G/H/I/J/N	for additional sensing of the piston position, can be ordered optionally, only in conjunction with the order code A in the drive's modular product section.	5 / 1.1-91
7 Plug socket with cable V	for proximity sensor	5 / 1.1-91
8 Slot nut for mounting slot Y	for mounting attachments	5 / 1.1-89
9 Central support M	to mount the axis	5 / 1.1-86
10 Foot mounting F	to mount the axis	5 / 1.1-86
11 Displacement encoder attachment position MA1 ... MA4/MP1 ... MP4	for drive position measurement	5 / 1.1-52

Linear drives DGPL, external displacement encoder

Type codes



		DGPL	-	25	-	500	-	PPV	-	A	-	B	-	KF	-	KU	-	GK	-	SV	-	D2	-	MP2
Type																								
DGPL	Linear drive unit																							
Piston Ø [mm]																								
Stroke [mm]																								
Cushioning																								
PPV	Pneumatic cushioning adjustable at both ends																							
Position sensing																								
A	For proximity sensing																							
Generation																								
B	B series																							
Guide																								
KF	Recirculating ball bearing guide																							
Clamping unit																								
KU	Clamping unit underneath																							
Basic variant																								
GK	Standard slide																							
GV	Extended slide																							
Slide attachment position																								
SV	Slide at front																							
SH	Slide at rear																							
Supply port																								
D2	Connection at both ends																							
Displacement encoder attachment position																								
MP1	Encoder, position 1, mounted																							
MP2	Encoder, position 2, mounted																							
MP3	Encoder, position 3, mounted																							
MP4	Encoder, position 4, mounted																							
MA1	Temposonic, position 1, mounted																							
MA2	Temposonic, position 2, mounted																							
MA3	Temposonic, position 3, mounted																							
MA4	Temposonic, position 4, mounted																							
MPO	Encoder, supplied separately																							
MA0	Temposonic, supplied separately																							

Linear drives DGPL, external displacement encoder

Type codes

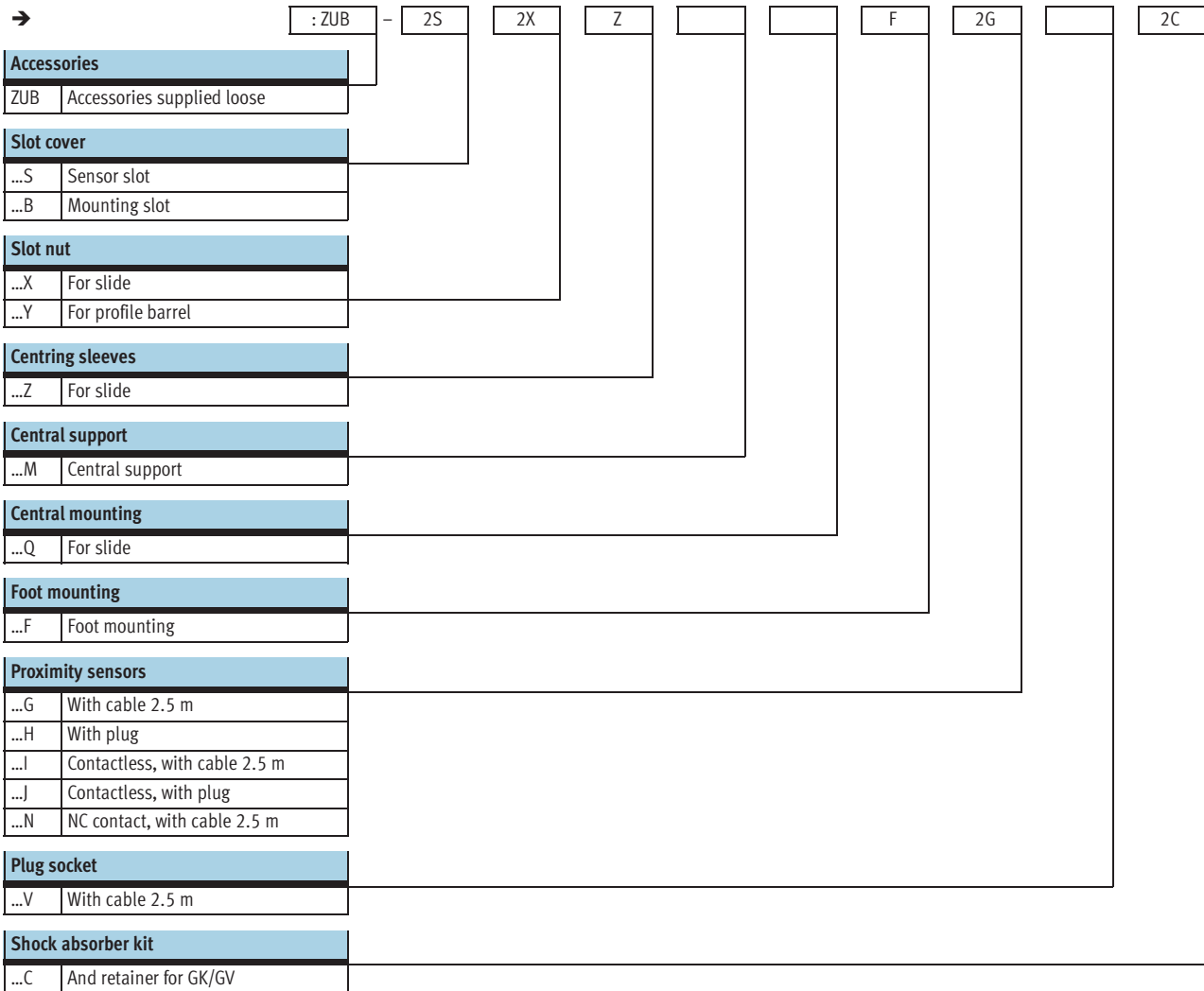



Linear drives DGPL, external displacement encoder

Technical data

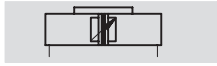

Function



-  - Diameter
25 ... 63 mm
-  - Stroke length
225 ... 2,000 mm

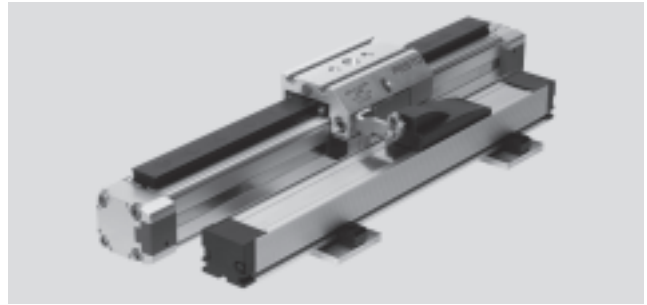

General technical data					
Piston Ø	25	32	40	50	63
Design	Piston				
	Driver				
	Profile barrel				
Mode of operation	Double-acting				
Operating medium ¹⁾	Compressed air, filtered and unlubricated, filter unit 5 µm				
Cushioning	Pneumatic cushioning adjustable at both ends				
Cushioning length [mm]	18	20	30		
Position sensing	Displacement encoder, attached externally				
	For proximity sensing				
Measuring principle (displacement encoder)	→ 5 / 1.2-3 Displacement encoders				
Type of mounting	Foot mounting				
Stroke ²⁾³⁾ [mm]	225, 300, 360, 450, 500, 600, 750, 1,000, 1,250, 1,500, 1,750, 2,000				
Protection against torsion/guide	Guide rail with slide				
	Recirculating ball bearing				
Clamping unit	→ Volume 1 (Linear drives DGPL)				
Pneumatic connection	G1/8		G1/4		G3/8
Electrical connection	→ 5 / 1.2-3 Displacement encoders				

- 1) The proportional directional control valve MPYE used requires the characteristic values.
- 2) Note stroke reduction in conjunction with SPC200.
- 3) Supply of compressed air to each end of the cylinder (feature D2) is absolutely essential for Soft Stop SPC11 and axis controller SPC200 as of a length of 500 mm.

Forces [N] and impact energy [Nm]					
Piston Ø	25	32	40	50	63
Theoretical force at 6 bar	295	483	754	1,178	1,870
Max. impact energy at the end positions ¹⁾	0.1	0.2	0.4	0.8	0.8

- 1) Cushioning PPV must be completely open for applications with Soft Stop SPC11 and axis controller SPC200.

Permissible impact velocity:

$$v_{perm.} = \sqrt{\frac{2 \times E_{perm.}}{m_{dead} + m_{load}}}$$

Maximum permissible load:

$$m_{load} = \frac{2 \times E_{perm.}}{v^2} - m_{dead}$$

 Note

This data represents the maximum values which can be achieved. Values fluctuate in practice relative to the size of the effective load. Allowance must also be made for the limits of the cushioning capacity of the drive and the permissible impact energy.

Linear drives DGPL, external displacement encoder

Technical data

Positioning characteristics with axis controller SPC200					
Piston Ø	25	32	40	50	63
Repetition accuracy [mm]	→ 5 / 1.1-46				
Mounting position	Any				
Minimum load, horizontal ¹⁾ [kg]	2	3	5	8	12
Maximum load, horizontal ¹⁾ [kg]	30	45	75	120	180
Minimum load, vertical ¹⁾ [kg]	2	3	5	8	12
Maximum load, vertical ¹⁾ [kg]	10	15	25	40	60
Min. speed of travel [m/s]	0.05				
Max. speed of travel [m/s]	3				
Typ. positioning time, long stroke ²⁾ [s]	0.80/1.20	0.90/1.25	0.80/1.20	1.00/1.25	0.95/1.25
Typ. positioning time, short stroke ³⁾ [s]	0.50/0.70	0.50/0.65	0.45/0.65	0.55/0.65	0.55/0.65
Minimum positioning stroke ⁴⁾ [%]	3				
Stroke reduction ⁵⁾ [mm]	25		35		
Recommended proportional directional control valve	→ 5 / 1.1-90				

- 1) Load = effective load + mass of all moving parts on the drive
- 2) At 6 bar, horizontal mounting position, DGPL-XX-1250, 1000 mm positioning travel at min./max. load
- 3) At 6 bar, horizontal mounting position, DNCM-XX-1250, 100 mm positioning travel at min./max. load
- 4) In relation to the maximum stroke of the drive, but never more than 20 mm.
- 5) The stroke reserve is to be maintained on every side of the drive, the max. positionable stroke is therefore: Stroke – 2x stroke reserve

Positioning characteristics with end position controller SPC11					
Piston Ø	25	32	40	50	63
Repetition accuracy of a mid-position ¹⁾ [mm]	±2				
Mounting position	Any				
Minimum load, horizontal ²⁾ [kg]	2	3	5	8	12
Maximum load, horizontal ²⁾ [kg]	30	45	75	120	180
Minimum load, vertical ²⁾ [kg]	2	3	5	8	12
Maximum load, vertical ²⁾ [kg]	10	15	25	40	60
Travel time [s]	→ Software Tool "SoftStop": www.festo.com/en/engineering				
Recommended proportional directional control valve	→ 5 / 1.1-90				

- 1) In the stroke range from 225 ... 2,000 mm
- 2) Load = effective load + mass of all moving parts on the drive

Operating and environmental conditions					
Piston Ø	25	32	40	50	63
Operating pressure ¹⁾ [bar]	4 ... 8				
Ambient temperature ²⁾ [°C]	-10 ... +60				
Vibration resistance	To DIN/IEC 68 Parts 2 -6, severity level 2				
Continuous shock resistance	To DIN/IEC 68 Parts 2 -27, severity level 2				
CE symbol	To 89/336/EEC (EMC regulation)				
Protection class (displacement encoder)	→ 5 / 1.2-3 Displacement encoders				

- 1) Only applies for applications with Soft Stop SPC11 and axis controller SPC200.
- 2) Note operating range of proximity sensors.

Linear drives DGPL, external displacement encoder

Technical data



Weights [g] without displacement encoder						
Piston Ø	25	32	40	50	63	
Basic weight	1,520	2,720	4,480	9,600	15,370	
Additional weight per 10 mm stroke	53	69	97	167	236	
Clamping unit	714	1,100	1,694	–	–	
Additional weight of clamping unit per 10 mm stroke	27	34	42	–	–	
Moving load	Standard slide GK	605	895	1,700	3,000	4,990
	Extended slide GV	950	1,375	2,603	4,700	7,860
	Clamping unit	185	250	461	–	–

- - Note

Electrical data, displacement encoder:	Analogue displacement encoder (Order code: MP) → 5 / 1.2-4	Digital displacement encoder (Order code: MA) → 5 / 1.2-8
--	--	---

Materials

Sectional view

Displacement encoder materials
→ 5 / 1.2-10

Drive	
1 End cap	Anodised aluminium
2 Profile	Anodised aluminium
3 Cover strip	Steel, corrosion resistant
4 Driver	Anodised aluminium
- Slide	Anodised aluminium
- Guide rail	Corrosion resistant steel
- Seals	Nitrile rubber, polyurethane

Repetition accuracy

Tolerance t [mm] as a function of the stroke l [mm]

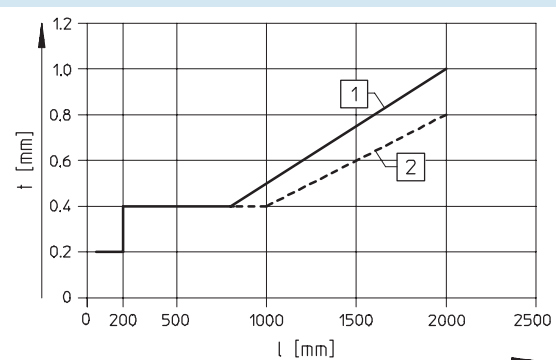
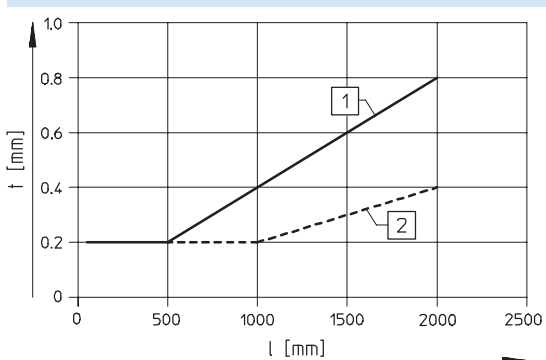

- 1 with analogue displacement encoder
- 2 with digital displacement encoder

Linear drives DGPL, external displacement encoder

Technical data



Characteristic load values

The forces and torques specified refer to the centre line of the profile barrel internal diameter.

They must not be exceeded during dynamic operation. Special attention must be paid to the cushioning phase.

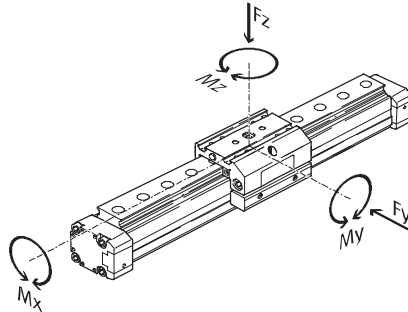

If the drive is subjected to more than two of the indicated forces and torques simultaneously, the following equations must be satisfied in addition to the indicated maximum loads.

$$0,4 \times \frac{F_z}{F_{z_{max}}} + \frac{M_x}{M_{x_{max}}} + \frac{M_y}{M_{y_{max}}} + 0,2 \times \frac{M_z}{M_{z_{max}}} \leq 1$$

$$\frac{F_z}{F_{z_{max}}} \leq 1 \quad \frac{M_z}{M_{z_{max}}} \leq 1$$

Permissible forces and torques

Piston Ø	Variant	25		32		40		50		63	
		GK	GV	GK	GV	GK	GV	GK	GV	GK	GV
$F_{y_{max}}$	[N]	3,080	3,080	3,080	3,080	7,300	7,300	7,300	7,300	14,050	14,050
$F_{z_{max}}$	[N]	3,080	3,080	3,080	3,080	7,300	7,300	7,300	7,300	14,050	14,050
$M_{x_{max}}$	[Nm]	45	45	63	63	170	170	240	240	580	580
$M_{y_{max}}$	[Nm]	85	170	127	250	330	660	460	920	910	1,820
$M_{z_{max}}$	[Nm]	85	170	127	250	330	660	460	920	910	1,820

Maximum permissible support span l as a function of the force F

The axis may need to be supported with central supports MUP in order to

limit deflection in the case of large strokes. The following diagrams serve

to determine the maximum permissible support span l as a

function of the force F.

Force on the surface of the slide

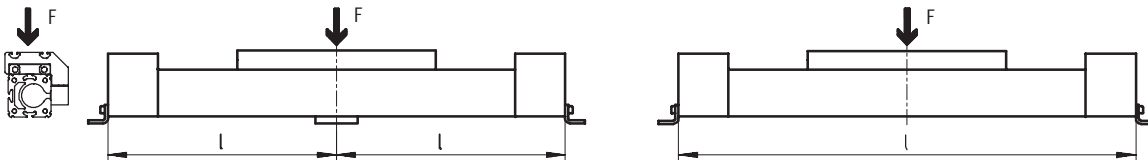

Maximum support span l (without central support) as a function of the force F

Piston Ø 25 ... 40

Piston Ø 50/63

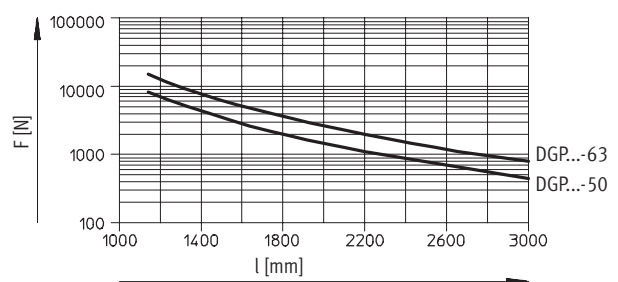
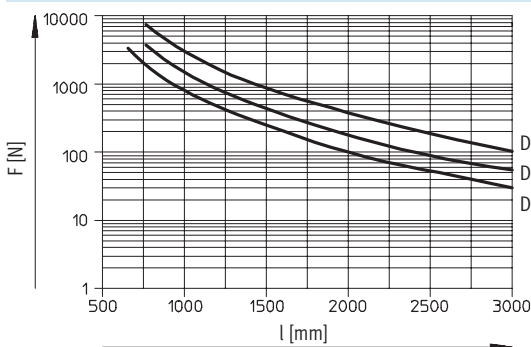

Linear drives DGPL, external displacement encoder

Technical data

FESTO

Dimensions

Download CAD data → www.festo.com/en/engineering

Standard slide GK

Piston $\varnothing 25$

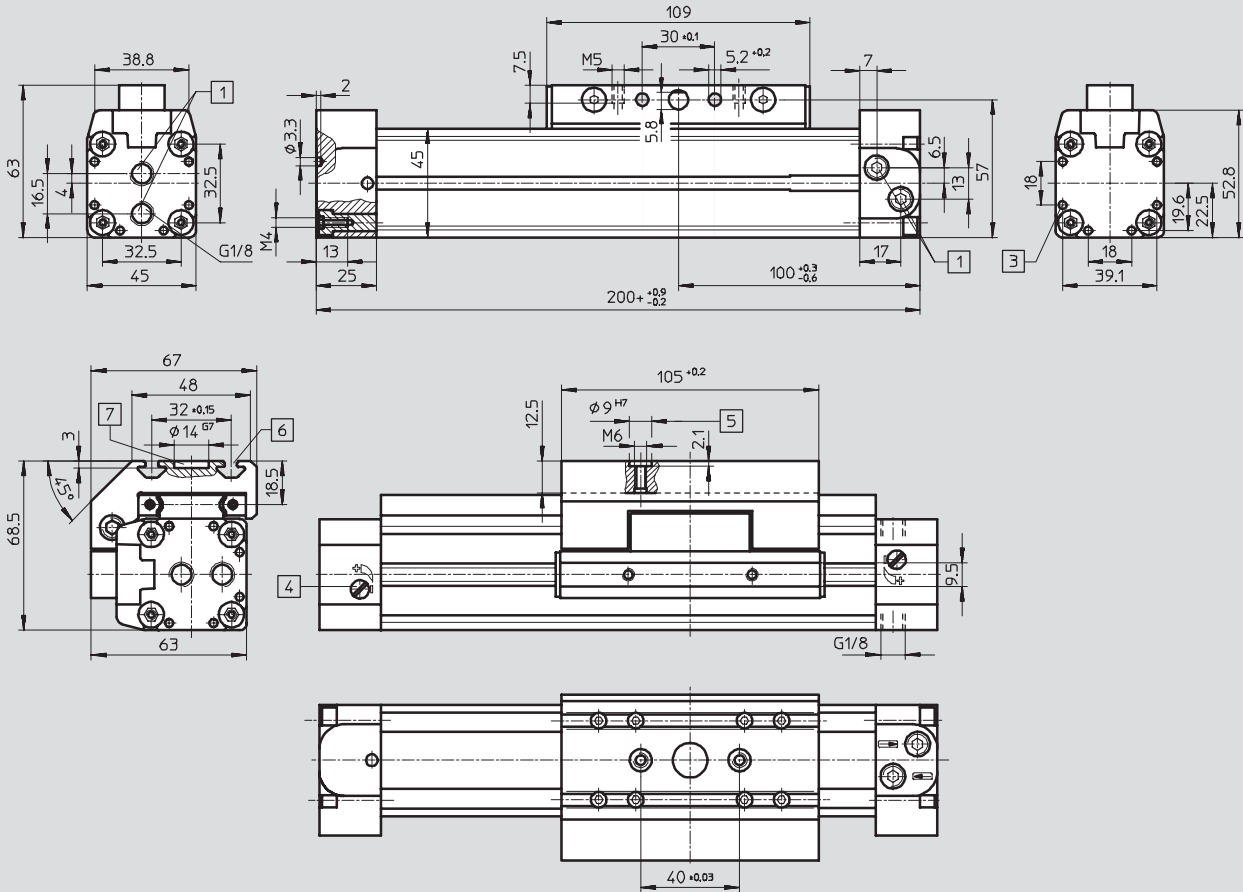

- 1 Supply ports at one end, option of three sides of an end cap (D2 variant: supply port at both ends, option of three sides per end cap)
 - 2 Mounting hole for foot mounting HP
 - 3 Mounting slot for slot nut NSTL
 - 4 Regulating screw for adjustable end-position cushioning
 - 5 Hole for centring sleeve ZBH-9
 - 6 Mounting slot for slot nut NSTL
 - 7 Drilled hole for central mounting SLZZ
- + = plus stroke length

Linear drives DGPL, external displacement encoder

Technical data



Extended slide GV

Piston $\varnothing 25$

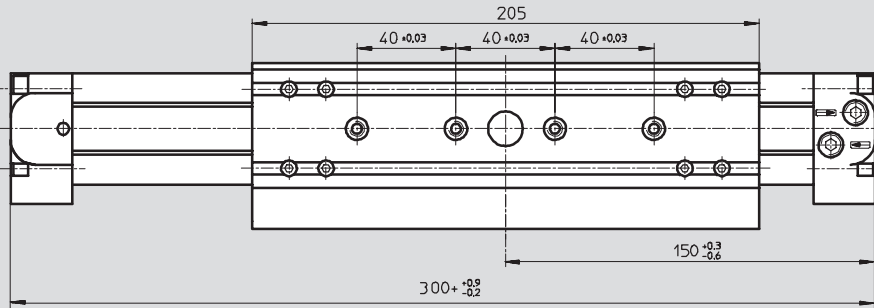

+ = plus stroke length

Profile barrel

Piston $\varnothing 25$

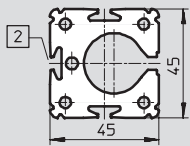

2 Sensor slot for proximity sensor

Linear drives DGPL, external displacement encoder

Technical data



Dimensions

Download CAD data → www.festo.com/en/engineering

Standard slide GK

Piston $\varnothing 32 \dots 63$

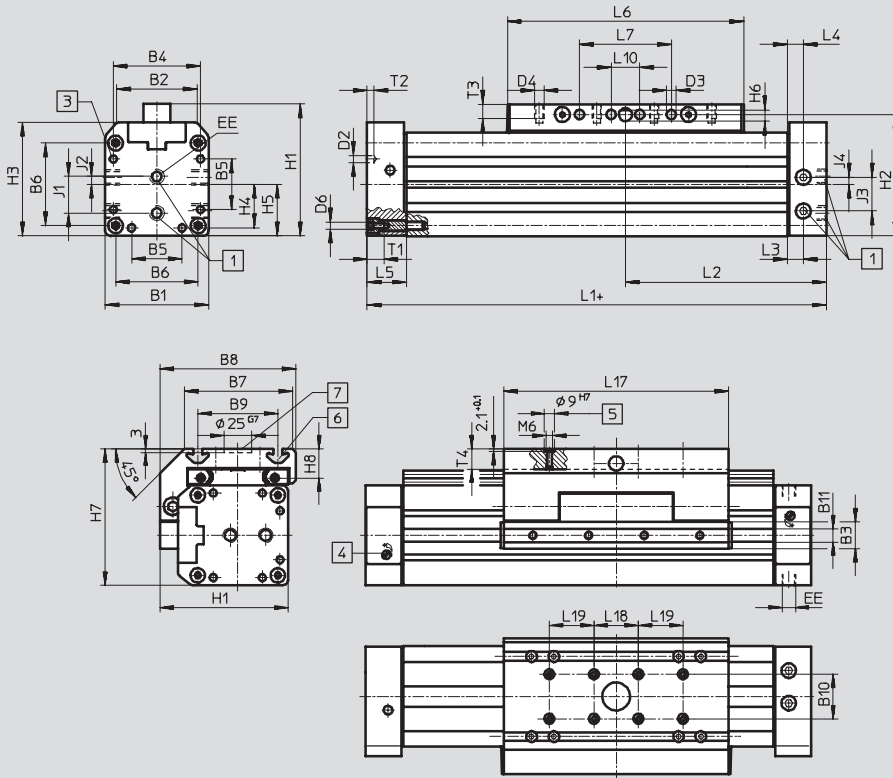

- 1 Supply ports at one end, option of three sides of an end cap (D2 variant: supply port at both ends, option of three sides per end cap)
 - 2 Mounting hole for foot mounting HP
 - 3 Regulating screw for adjustable end-position cushioning
 - 4 Hole for centring sleeve ZBH-9
 - 5 Mounting slot for slot nut NSTL
 - 6 Drilled hole for central mounting SLZZ
 - 7 Slot for slot nut NSTL
- + = plus stroke length

Extended slide GV

Piston $\varnothing 32 \dots 63$

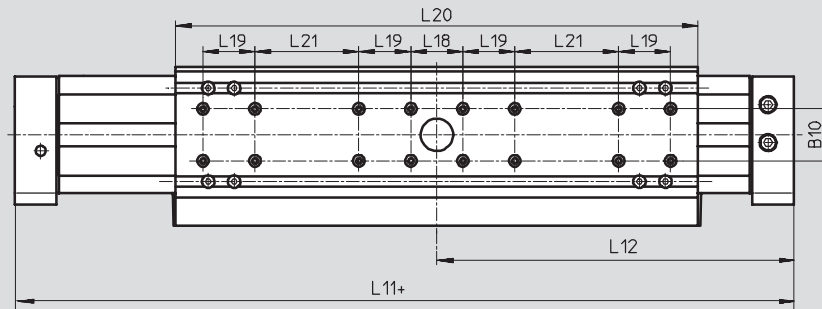

Profile barrel

Piston $\varnothing 32$

Piston $\varnothing 40$

Piston $\varnothing 50$

Piston $\varnothing 63$

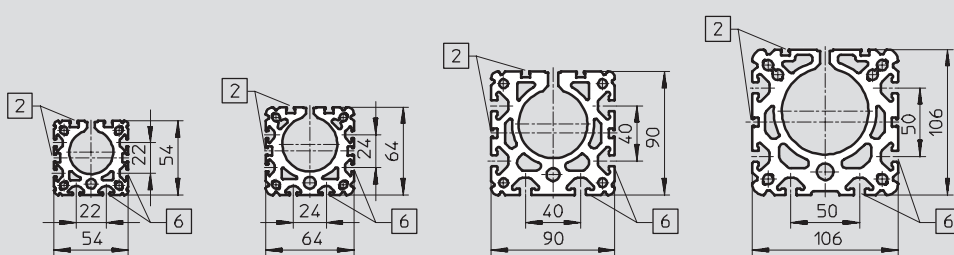

- 2 Sensor slot for proximity sensor
- 6 Mounting slot for slot nut NST

Linear drives DGPL, external displacement encoder



Technical data

∅ [mm]	B1	B2	B3 +0.2	B4	B5	B6	B7	B8	B9	B10 ±0.03	B11	D2 ∅
32	54	35.8	19	46	21	40	63	79	47 ±0.15	20	9.5	4.3
40	64	45.7	21	53	28	49	78.5	96.5	55 ±0.2			
50	90	69.2	24	76	44	72	97	122	72 ±0.2	40	12	6.3
63	106	84.8		89		83	121	142	90 ±0.25			

∅ [mm]	D3 ∅ +0.2	D4	D6	EE	H1	H2	H3	H4	H5	H6	H7	H8
32	5.2	M5	M5	G1/8	72	66	62	23	27	5.8	77.5	18.5
40	6.5	M6		G1/4	86	78	71.8	26.5	32	7.7	90.5	20
50	8.5	M8	M6	G3/8	115	106	99	36	45	9.7	122.5	26
63			M8		131	122	115	44.5	53		144.5	30

∅ [mm]	J1	J2	J3	J4	L1 +0.9/-0.2	L2 +0.3/-0.6	L3	L4	L5	L6	L7	L10 ±0.15
32	19	4.2	14	4.7	250	125	17	8.5	31	135	50 ±0.1	-
40	22	5	21	9.1	300	150	11.5	11.5		171	70 ±0.1	
50	31.8	6.8	29.3	6	350	175	14	14	34	206	80 ±0.1	
63	36	8	31	14	400	200				234	110 ±0.1	

∅ [mm]	L11 +0.9/-0.2	L12 +0.3/-0.6	L17	L18 ±0.03	L19 ±0.03	L20	L21 ±0.1	T1	T2	T3	T4 max.
32	380	190	131 ±0.2	40	-	261	40	13.2	3	7.5	12.5
40	470	235	167 ±0.2		40	337			4	10.5	
50	550	275	202 ±0.2		402	80	15.2	6	12.5	18.5	
63	650	325	230 ±0.2		480	120	21.2			20.5	

- - Note
Accessories → 5 / 1.1-86

Servopneumatic positioning systems
Cylinders with displacement encoders

1.1

Linear drives DGPL, external displacement encoder

Ordering data – Modular product system



Order code

Mandatory data/Options

- KU Clamping unit underneath
- GK Standard slide
- GV Extended slide
- SV Slide at rear
- SH Slide at front
- D2 Air connection at both ends

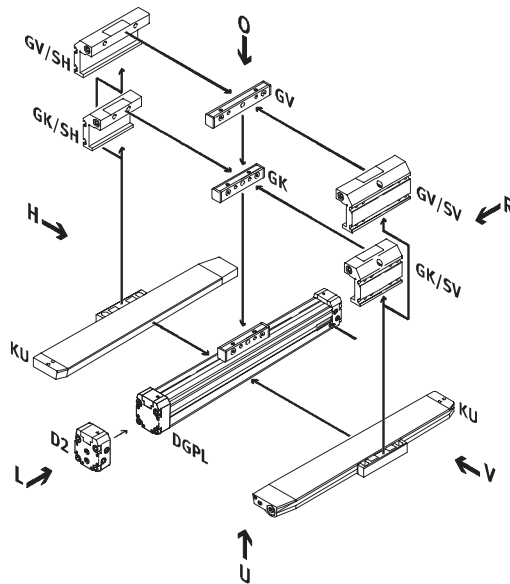

Attachment position for slides at rear (SH)

- MP Analogue displacement encoder
- MA Digital displacement encoder

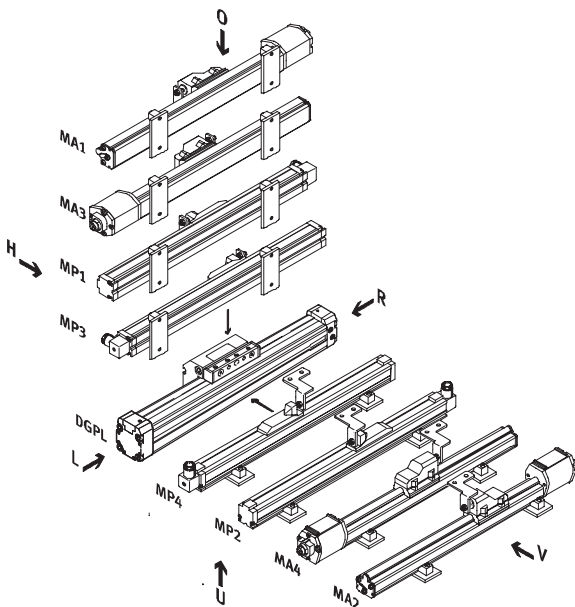

Attachment position for slides at front (SV)

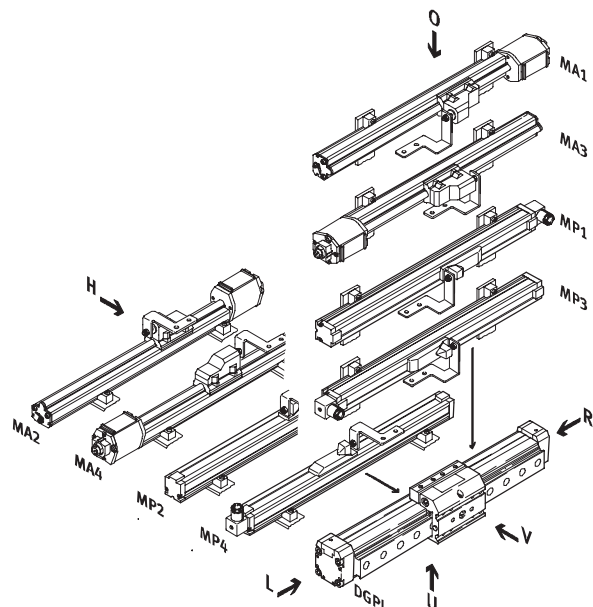

- - Note
- O top
- U underneath
- R right
- L left
- V front
- H rear

Linear drives DGPL, external displacement encoder

Ordering data – Modular product system



Order code

Options

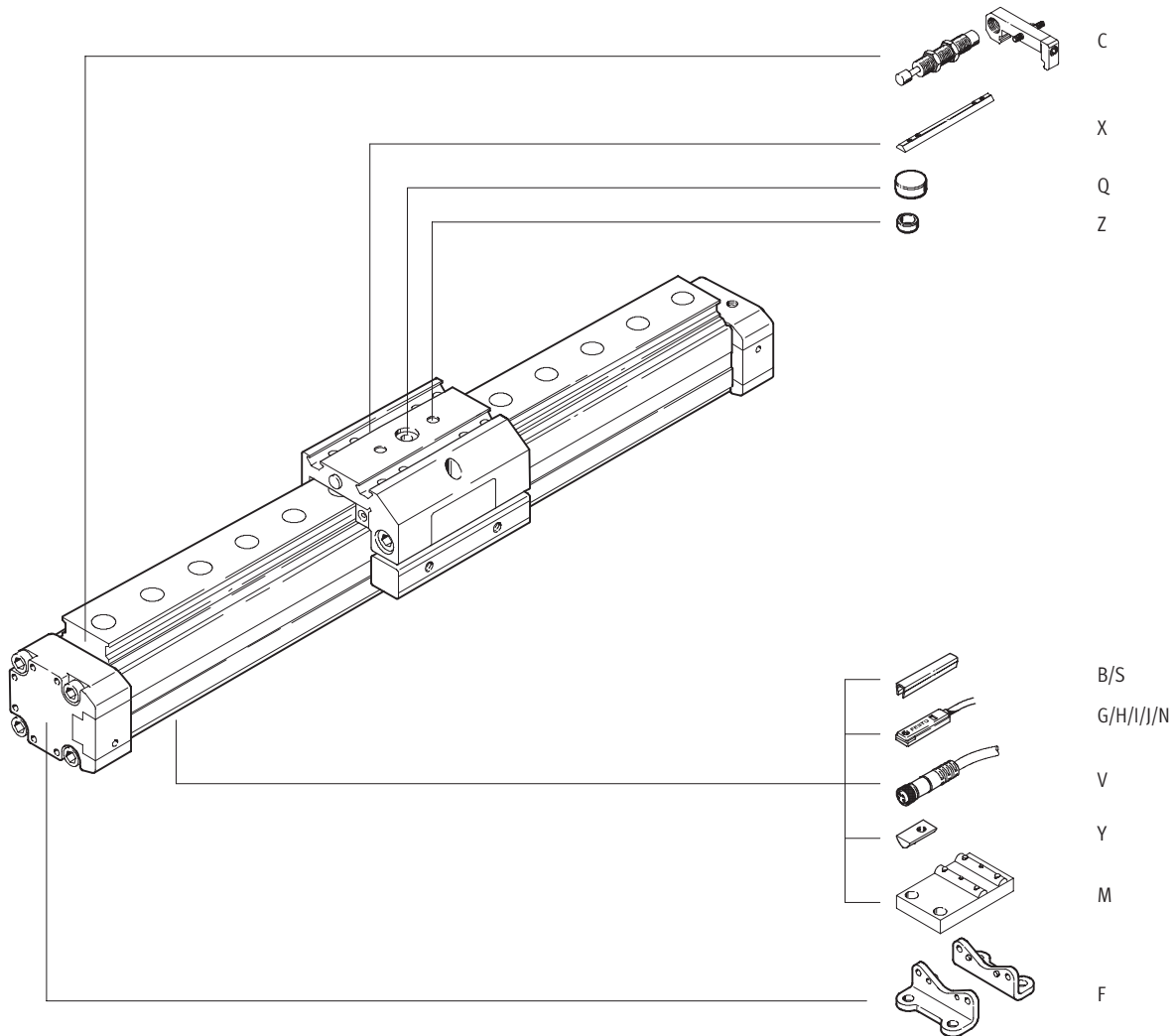

Linear drives DGPL, external displacement encoder

Ordering data – Modular product system



1.1

M Mandatory data								O Options				
Module No.	Drive function	Size	Stroke	Cushioning	Position sensing	Generation	Guide	Clamping unit	Basic variant	Slide attachment position	Supply port	Displacement encoder
175 134	DGPL	25	225 ... 2 000	PPV	A	B	KF	KU	GK GV	SV SH	D2	MP1
175 135		32										MP2
175 136		40										MP3
175 137		50										MP4
175 138		63										MA1 MA2 MA3 MA4 MP0 MA0
Ordering example												
175 136	DGPL	40	750	PPV	A	B	KF		GV	SH	D2	MA2

Ordering table									
Size	25	32	40	50	63	Condi- tions	Code	Enter code	
M Module No.	175 134	175 135	175 136	175 137	175 138				
Drive function	Pneumatic linear drive with slide						DGPL	DGPL	
Size	25	32	40	50	63	-...			
Stroke [mm]	225, 300, 360, 450, 500, 600, 750, 1 000, 1 250, 1 500, 1 750, 2 000						-...		
Cushioning	Pneumatic cushioning adjustable at both ends						-PPV	-PPV	
Position sensing	For proximity sensing						-A	-A	
Generation	B series						-B	-B	
Guide	Recirculating ball bearing guide						-KF	-KF	
O Clamping unit	Underneath				-	-	-KU		
Basic variant	Standard piston/slide						1 -GK		
	Extended piston/slide						-GV		
Slide attachment position	Slide at front						2 -SV		
	Slide at rear						-SH		
Supply port	at both ends						-D2		
Displacement encoder	Encoder, position 1, mounted						-MP1		
	Encoder, position 2, mounted						3 -MP2		
	Encoder, position 3, mounted						-MP3		
	Encoder, position 4, mounted						3 -MP4		
	Temposonic with CAN axis interface, position 1, mounted						-MA1		
	Temposonic with CAN axis interface, position 2, mounted						3 -MA2		
	Temposonic with CAN axis interface, position 3, mounted						-MA3		
	Temposonic with CAN axis interface, position 4, mounted						3 -MA4		
	Encoder, supplied separately						-MP0		
	Temposonic with CAN axis interface, supplied separately						-MA0		

- 1 GK or GV Must be selected
- 2 SV or SH Must be selected
- 3 MP2, MP4, MA2, MA4 Not with clamping unit KU

Transfer order code

Linear drives DGPL, external displacement encoder

Ordering data – Modular product system



Options									
Accessories	Slot cover	Slot nut	Centring sleeve	Central support	Central mounting	Foot mounting	Proximity sensor, magnetic	Plug socket	Shock absorber kit
ZUB	...S ...B	...X ...Y	...Z	...M	...Q	...F	...G ...H ...I ...J ...N	...V	...C
: ZUB	- 2S2B	2XY	Z		Q	F			2C

Ordering table													
Size	25		32		40		50		63		Condi- tions	Code	Enter code
↓ Accessories	Supplied separately											:ZUB-	:ZUB-
0 Slot cover, x2, 0.5 m	Sensor slot	1 ... 10										...S	
	Mounting slot	-		1 ... 10								...B	
Slot nut	Slide	1 ... 10										...X	
	Mounting slot	-		1 ... 10								...Y	
Centring sleeve (pack of 10)	10, 20, 30, 40, 50, 60, 70, 80, 90										...Z		
Central support	1 ... 10										...M		
Central mounting	1 ... 10										...Q		
Foot mounting	1 ... 10										...F		
Magnetic proximity sensor	With cable 2.5 m	1 ... 10 (SME-8-K-LED-24)										...G	
	With plug	1 ... 10 (SME-8-S-LED-24)										...H	
Magnetic proximity sensor, contactless	With cable 2.5 m	1 ... 10 (SMT-8-PS-K-LED-24)										...I	
	With plug	1 ... 10 (SMT-8-PS-S-LED-24)										...J	
Magnetic proximity sensor	NC contact, with cable 2.5 m	1 ... 10 (SME-8-O-K-LED-24)										...N	
Plug socket	With cable 2.5 m	1 ... 10 (SIM-M8-3GD-2,5-PU)										...V	
Shock absorber kit	1 ... 10										...C		

Transfer order code

: ZUB - [] [] [] [] [] [] [] [] [] [] []

Linear drives DGPI/DGPIL, integrated displacement encoder

Features



Individual positioning components with linear drive DGPI/DGPIL ...

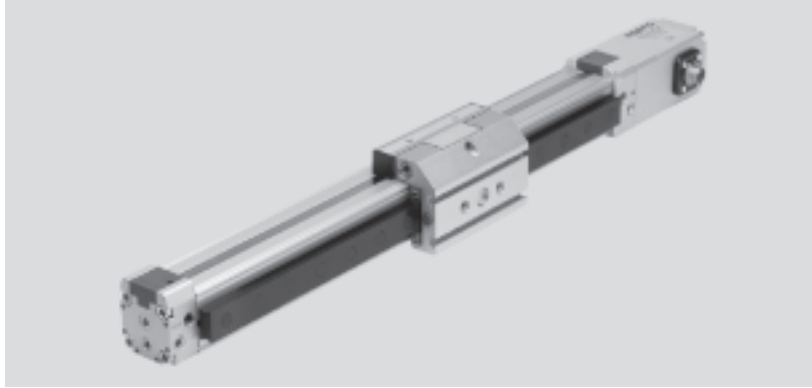

Proportional directional control valve
MPYE-...
→ 5 / 1.5-2



Soft Stop → 5 / 1.4-2

Positioning technology → 5 / 1.3-2

End position controller
SPC11-MTS-AIF



Axis interface
SPC-AIF-MTS



Axis positioning controller
SPC200



Linear drives DGPI/DGPIL, integrated displacement encoder

Features

DGPI, without guide

5 / 1.1-58

- Piston \varnothing 25 ... 63 mm
- Stroke 225 ... 2,000 mm
- Standard driver
- Low characteristic load values
- Air connections on both sides



DGPIL, with recirculating ball bearing guide

5 / 1.1-72

- Piston \varnothing 25 ... 63 mm
- Stroke 225 ... 2,000 mm
- Standard slide
- High characteristic load values
- Air connections on both sides



DGPIL, with recirculating ball bearing guide and protected version

5 / 1.1-72

- Piston \varnothing 25...40 mm
- Stroke 225 ... 2,000 mm
- Protected from above and the sides against the ingress of particles
- High characteristic load values
- Air connections on both sides



Linear drives DGPI, integrated displacement encoder

Peripherals overview

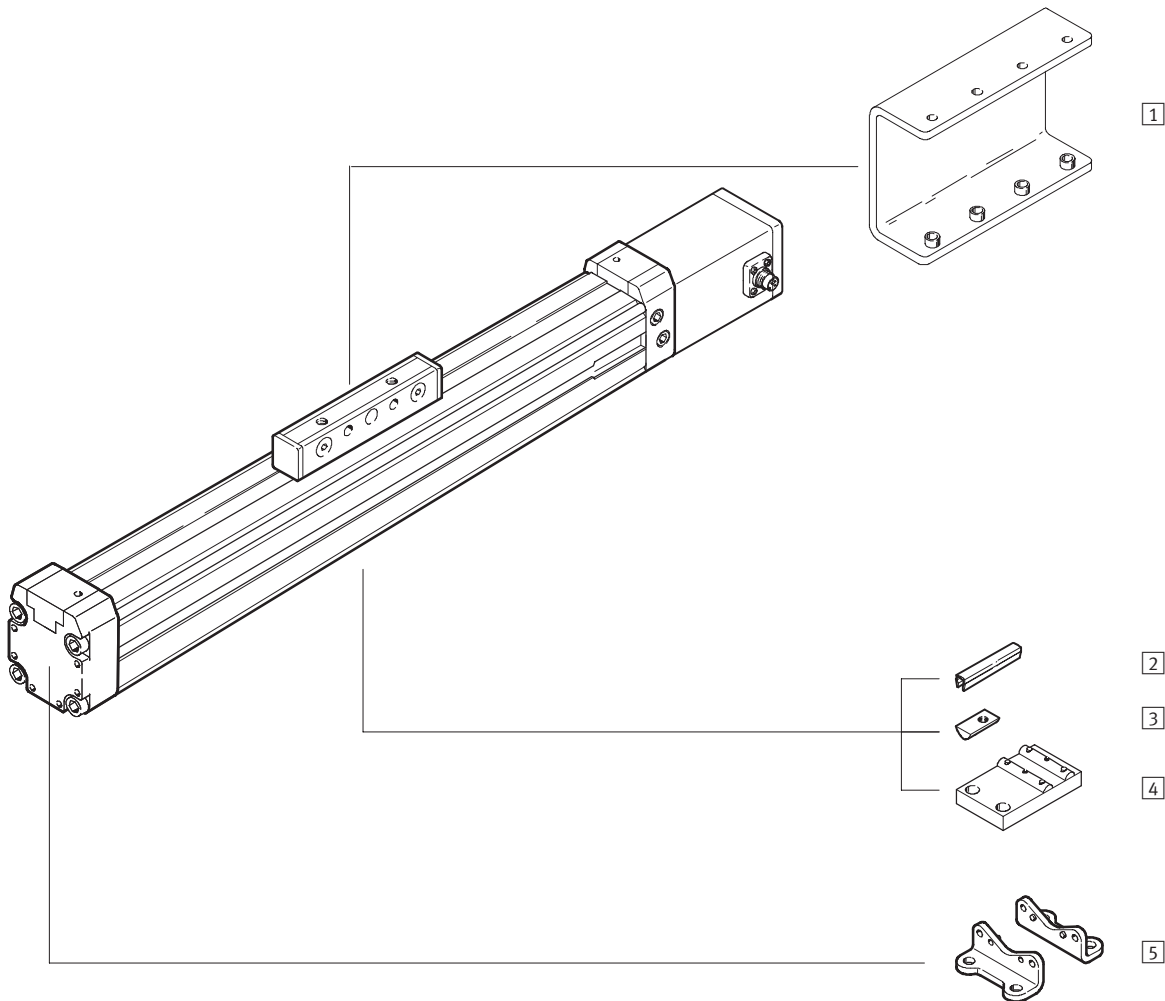

Variants and accessories		
Type	Brief description	→ Page
1 Load inverter AK	to secure the load from beneath, is supplied attached	5 / 1.1-87
2 Slot cover B/S	to protect against the ingress of dirt	5 / 1.1-89
3 Slot nut Y	for mounting attachments	5 / 1.1-89
4 Central support M	to mount the axis	5 / 1.1-86
5 Foot mounting F	to mount the axis	5 / 1.1-86

Linear drives DGPI, integrated displacement encoder

Type codes

		DGPI	-	25	-	500	-	PPV	-	AIF	-	GK	-	AV	-	AK	-	D2	-	4BYF
Type		DGPI																		
	Linear drive unit																			
Piston Ø [mm]																				
Stroke [mm]																				
Cushioning		PPV	Pneumatic cushioning adjustable at both ends																	
Displacement encoder		AIF	Temposonic with CAN axis interface																	
Basic variant		GK	Standard slide																	
Connection position for displacement encoder and compressed air		AH	Connections at rear																	
	AU	Connections underneath																		
	AV	Connections at front																		
Driver		AK	Load inverter																	
Air supply port		D2	Connection at both ends																	
Accessories supplied loose		...S	Slot cover for sensor slot																	
	...B	Slot cover for mounting slot																		
	...Y	Slot nut for mounting slot																		
	...M	Central support																		
	...F	Foot mounting																		

Linear drives DGPI, integrated displacement encoder

Technical data



Function

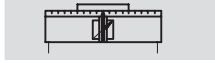

- - Diameter
25 ... 63 mm
- - Stroke length
225 ... 2,000 mm

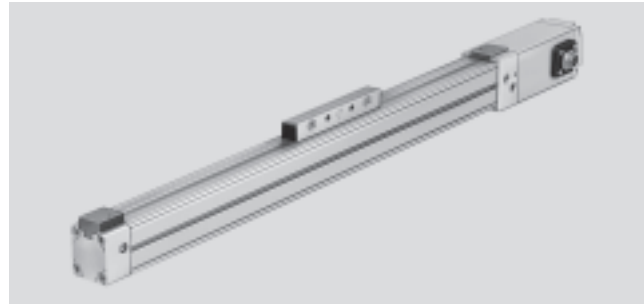

General technical data					
Piston \varnothing	25	32	40	50	63
Design	Piston				
	Driver				
	Profile barrel				
Mode of operation	Double-acting				
Operating medium ¹⁾	Compressed air, filtered and unlubricated, filter unit 5 μ m				
Cushioning	Pneumatic cushioning adjustable at both ends				
Cushioning length [mm]	18	20	30		
Position sensing	Integrated displacement encoder				
Measuring principle	Digital, magnetostrictive, non-contacting, absolute measurement				
Type of mounting	Foot mounting				
Stroke ²⁾³⁾ [mm]	225, 300, 360, 450, 500, 600, 750, 1,000, 1,250, 1,500, 1,750, 2,000				
Pneumatic connection	G1/8		G1/4		G3/8
Electrical connection	6-pin round plug to DIN 45 322				

- 1) The proportional directional control valve MPYE used requires the characteristic values.
- 2) Note stroke reduction in conjunction with SPC200.
- 3) Supply of compressed air to each end of the cylinder (feature D2) is absolutely essential for Soft Stop SPC11 and axis controller SPC200 as of a length of 500 mm.

Forces [N] and impact energy [Nm]					
Piston \varnothing	25	32	40	50	63
Theoretical force at 6 bar	295	483	754	1,178	1,870
Max. impact energy at the end positions ¹⁾	0.1	0.2	0.4	0.8	0.8

- 1) Cushioning PPV must be completely open for applications with Soft Stop SPC11 and axis controller SPC200.

Permissible impact velocity:

$$v_{\text{perm.}} = \sqrt{\frac{2 \times E_{\text{perm.}}}{m_{\text{dead}} + m_{\text{load}}}}$$

Maximum permissible load:

$$m_{\text{load}} = \frac{2 \times E_{\text{perm.}}}{v^2} - m_{\text{dead}}$$

- Note

This data represents the maximum values which can be achieved. Values fluctuate in practice relative to the size of the effective load. Allowance must also be made for the limits of the cushioning capacity of the drive and the permissible impact energy.

Linear drives DGPI, integrated displacement encoder

Technical data

Positioning characteristics with axis controller SPC200					
Piston Ø	25	32	40	50	63
Repetition accuracy [mm]	→ 5 / 1.1-46				
Mounting position	Any				
Minimum load, horizontal ¹⁾ [kg]	2	3	5	8	12
Maximum load, horizontal ¹⁾ [kg]	30	45	75	120	180
Minimum load, vertical ¹⁾ [kg]	2	3	5	8	12
Maximum load, vertical ¹⁾ [kg]	10	15	25	40	60
Min. speed of travel [m/s]	0.05				
Max. speed of travel [m/s]	3				
Typ. positioning time, long stroke ²⁾ [s]	0.75/1.20	0.85/1.20	0.75/1.20	0.95/1.25	0.90/1.20
Typ. positioning time, short stroke ³⁾ [s]	0.40/0.60	0.45/0.60	0.40/0.60	0.50/0.65	0.50/0.65
Minimum positioning stroke ⁴⁾ [%]	3				
Stroke reduction ⁵⁾ [mm]	25		35		
Recommended proportional directional control valve	→ 5 / 1.1-90				

- 1) Load = effective load + mass of all moving parts on the drive
- 2) At 6 bar, horizontal mounting position, DGPL-XX-1250, 1000 mm positioning travel at min./max. load
- 3) At 6 bar, horizontal mounting position, DNCM-XX-1250, 100 mm positioning travel at min./max. load
- 4) In relation to the maximum stroke of the drive, but never more than 20 mm.
- 5) The stroke reserve is to be maintained on every side of the drive, the max. positionable stroke is therefore: Stroke – 2x stroke reserve

Positioning characteristics with end position controller SPC11					
Piston Ø	25	32	40	50	63
Repetition accuracy of a mid-position ¹⁾ [mm]	±2				
Mounting position	Any				
Minimum load, horizontal ²⁾ [kg]	2	3	5	8	12
Maximum load, horizontal ²⁾ [kg]	30	45	75	120	180
Minimum load, vertical ²⁾ [kg]	2	3	5	8	12
Maximum load, vertical ²⁾ [kg]	10	15	25	40	60
Travel time [s]	→ Software Tool "SoftStop": www.festo.com/en/engineering				
Recommended proportional directional control valve	→ 5 / 1.1-90				

- 1) In the stroke range from 225 ... 2,000 mm
- 2) Load = effective load + mass of all moving parts on the drive

Operating and environmental conditions					
Piston Ø	25	32	40	50	63
Operating pressure ¹⁾ [bar]	4 ... 8				
Ambient temperature [°C]	-10 ... +60				
Vibration resistance	To DIN/IEC 68 Parts 2 -6, severity level 1				
Continuous shock resistance	To DIN/IEC 68 Parts 2 -27, severity level 1				
CE marking symbol (see conformity declaration)	As per EU EMC directive				
Protection class (displacement encoder)	IP65 to IEC 60 529				
Corrosion resistance class CRC ²⁾	1				

- 1) Only applies for applications with Soft Stop SPC11 and axis controller SPC200.
- 2) Corrosion resistance class 1 according to Festo standard 940 070
Components requiring low corrosion resistance. Transport and storage protection. Parts that do not have primarily decorative surface requirements, e.g. in internal areas that are not visible or behind covers.

Weights [g]					
Piston Ø	25	32	40	50	63
Basic weight	1,540	2,150	3,500	6,980	10,600
Additional weight per 10 mm stroke	38	43	59	130	168
Moving load	180	314	551	1,045	1,775

Linear drives DGPI, integrated displacement encoder

Technical data

FESTO

Electrical data, displacement encoder		
Power supply	[V DC]	24 (-15/+25%)
Max. current consumption	[mA]	90
Resolution	[mm]	≤ 0.01
Independent linearity ¹⁾	maximum [%]	0.02
Temperature coefficient	[ppm/°K]	≤ 15
Interface		Digital, CAN with protocol: SPC-AIF

1) Minimum ±50 µm

Materials

Sectional view

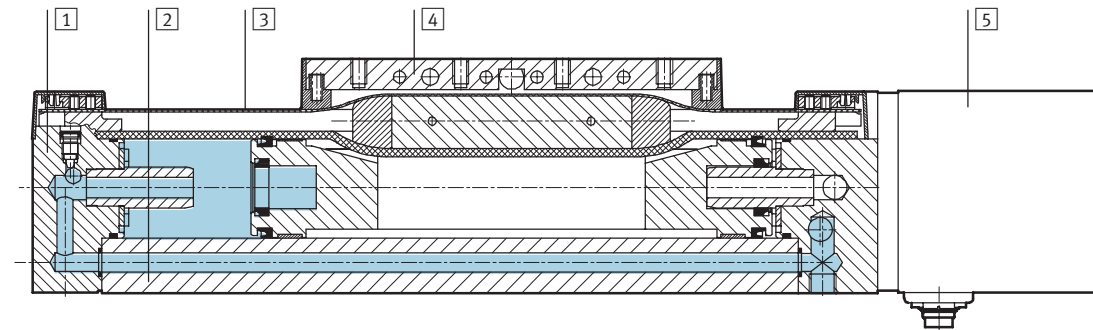

Drive		
1	End cap	Anodised aluminium
2	Profile	Anodised aluminium
3	Cover strip	Steel, corrosion resistant
4	Driver	Anodised aluminium
5	Displacement encoder housing	Anodised aluminium
-	Seals	Nitrile rubber, polyurethane

-  - Note
Further technical data
➔ Volume 1 (Linear drives DGPI)

Linear drives DGPI, integrated displacement encoder

Technical data



Characteristic load values

The forces and torques specified refer to the centre line of the profile barrel internal diameter.

They must not be exceeded during dynamic operation. Special attention must be paid to the cushioning phase.

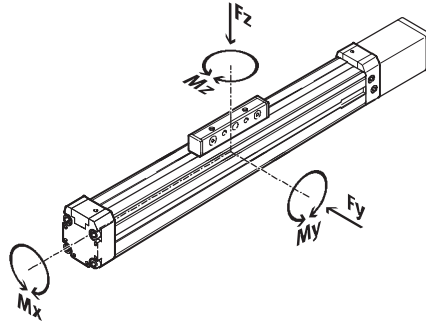

If the drive is subjected to more than two of the indicated forces and torques simultaneously, the following equations must be satisfied in addition to the indicated maximum loads.

$$0,4 \times \frac{F_z}{F_{z_{max}}} + \frac{M_x}{M_{x_{max}}} + \frac{M_y}{M_{y_{max}}} + 0,2 \times \frac{M_z}{M_{z_{max}}} \leq 1$$

$$\frac{F_z}{F_{z_{max}}} \leq 1 \quad \frac{M_z}{M_{z_{max}}} \leq 1$$

Permissible forces and torques

Piston Ø	25	32	40	50	63
F _y _{max.} [N]	–	–	–	–	–
F _z _{max.} [N]	330	480	800	1,200	1,600
M _x _{max.} [Nm]	1	2	4	7	8
M _y _{max.} [Nm]	20	40	60	120	120
M _z _{max.} [Nm]	3	5	8	15	24

Maximum permissible support span l as a function of the force F

The axis may need to be supported with central supports MUP in order to

limit deflection in the case of large strokes. The following diagrams serve

to determine the maximum permissible support span l as a

function of the force F.

Force on the surface of the slide

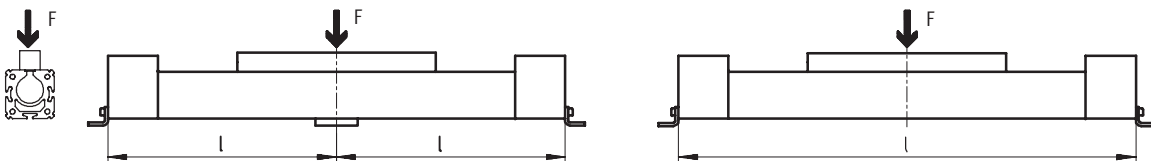

Maximum support span l (without central support) as a function of the force F

Piston Ø 25 ... 40

Piston Ø 50/63

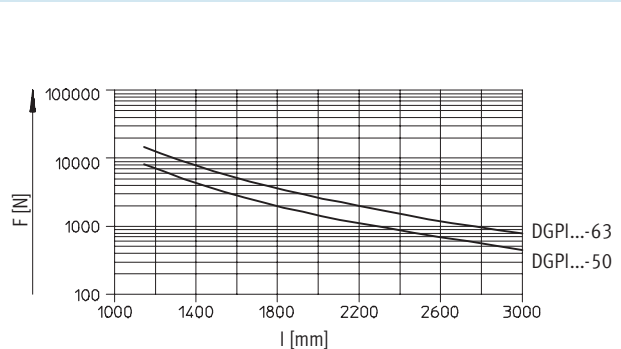
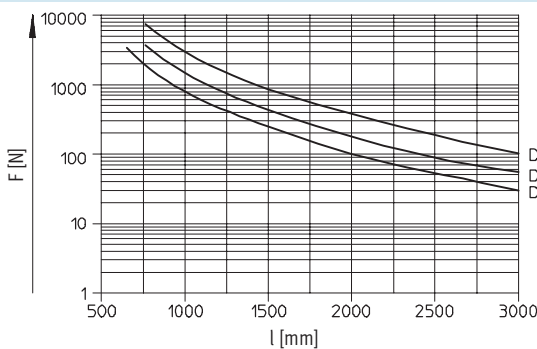

Linear drives DGPI, integrated displacement encoder

Technical data

FESTO

Dimensions

Download CAD data → www.festo.com/en/engineering

Standard driver GK

Piston $\varnothing 25$

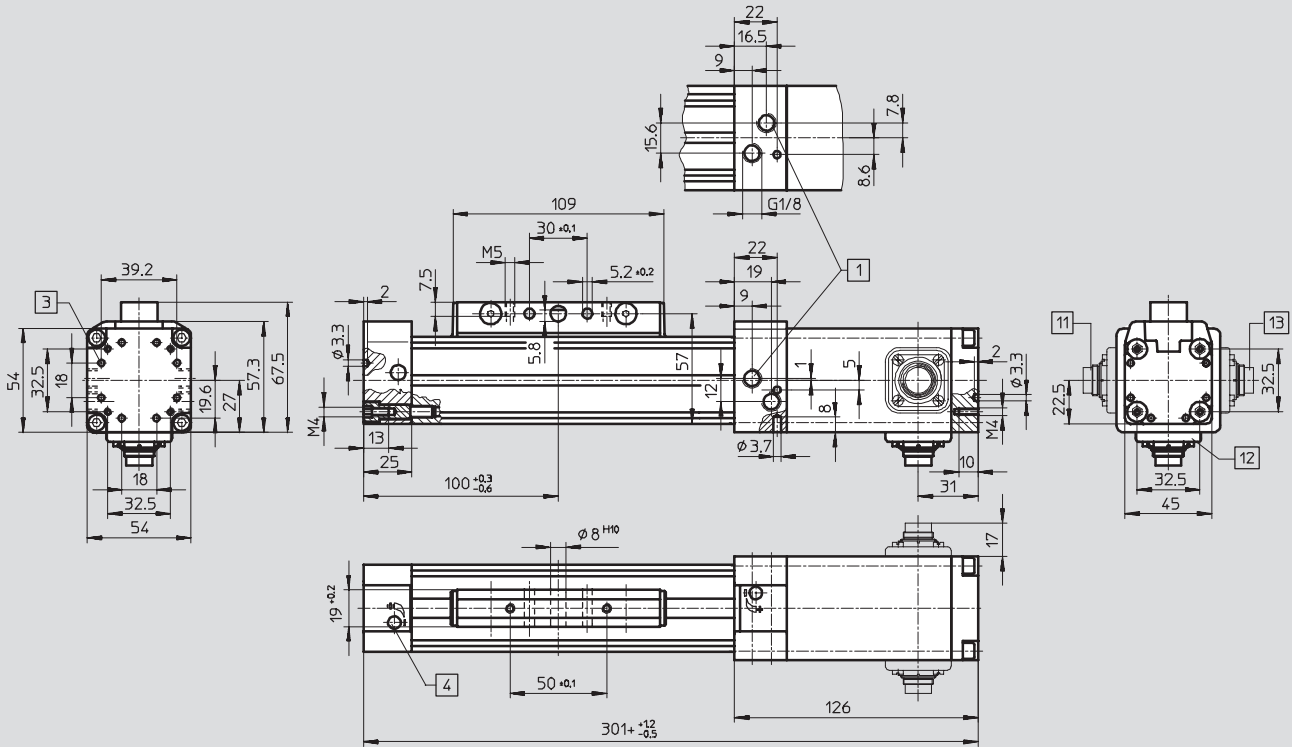

- 1 Both compressed air connections can be optionally connected to three sides of the right-hand end cap
- 3 Mounting holes for foot mounting HP

- 4 Regulating screw for adjustable end-position cushioning + = plus stroke length
- 11 Encoder connection at rear
- 12 Encoder connection underneath
- 13 Encoder connection at front

Linear drives DGPI, integrated displacement encoder

Technical data

FESTO

Dimensions

Download CAD data → www.festo.com/en/engineering

Supply port D2 at both sides

Piston $\varnothing 25$

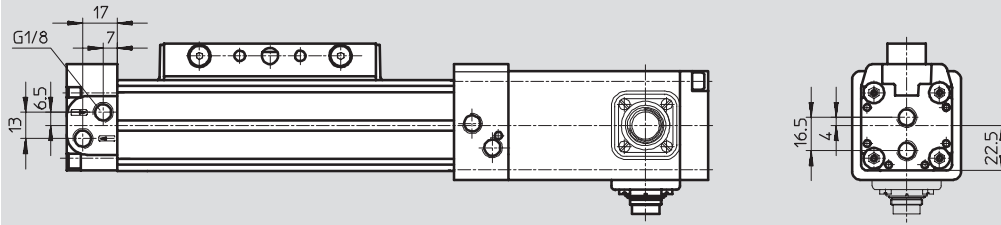

Profile barrel

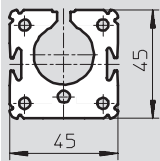

Servopneumatic positioning systems
Cylinders with displacement encoders

1.1

Linear drives DGPI, integrated displacement encoder

Technical data



Dimensions

Download CAD data → www.festo.com/en/engineering

Standard driver GK

Piston \varnothing 32 ... 63

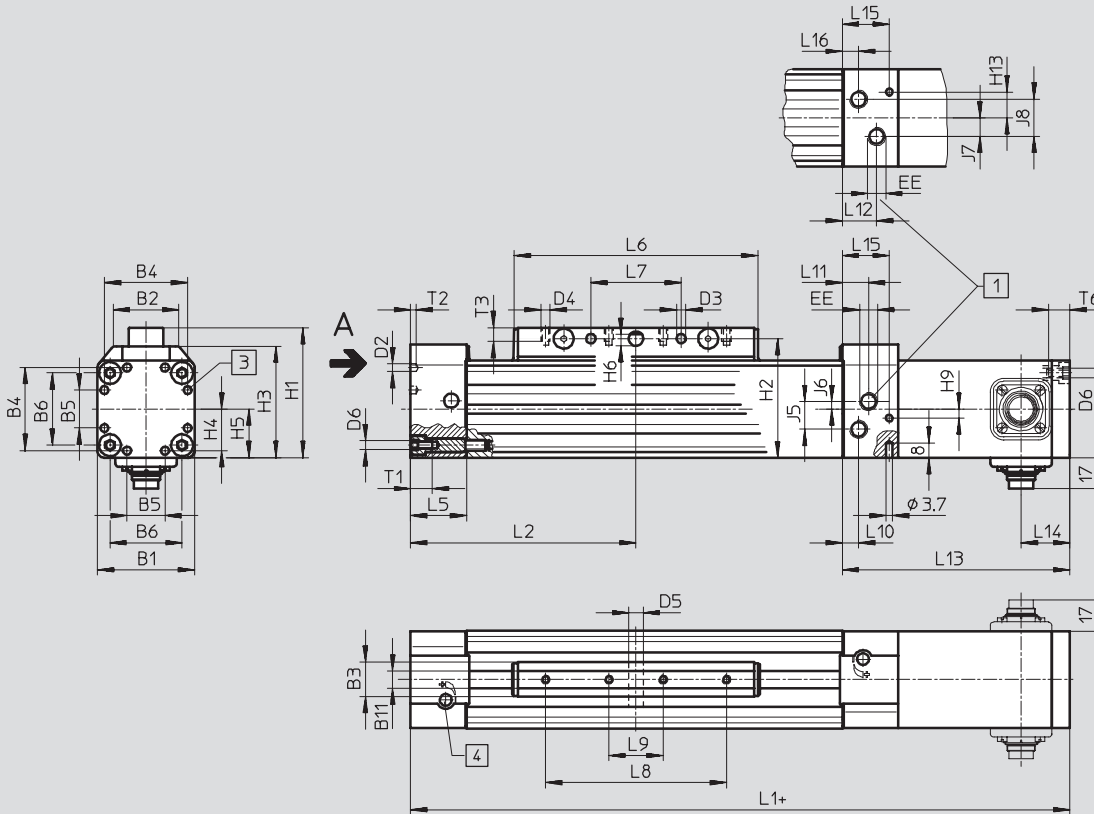

- 1 Both compressed air connections can be optionally connected to three sides of the right-hand end cap
- 2 Mounting holes for foot mounting HP
- 3 Regulating screw for adjustable end-position cushioning
- 4 Encoder connection at rear
- 5 Encoder connection underneath
- 6 Encoder connection at front
- 7 + = plus stroke length

View A

Piston \varnothing 32/40

Piston \varnothing 50

Piston \varnothing 63

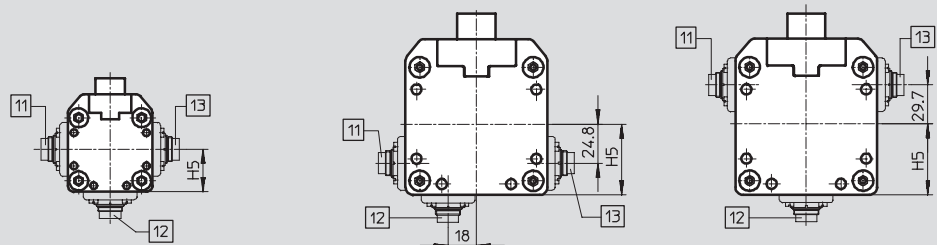

Supply port D2 at both sides

Piston \varnothing 32 ... 63

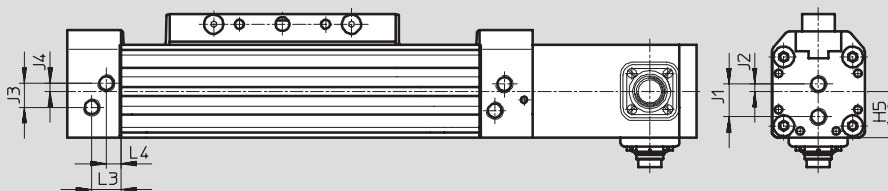

Linear drives DGPI, integrated displacement encoder

Technical data

FESTO

Dimensions Download CAD data → www.festo.com/en/engineering

Profile barrel

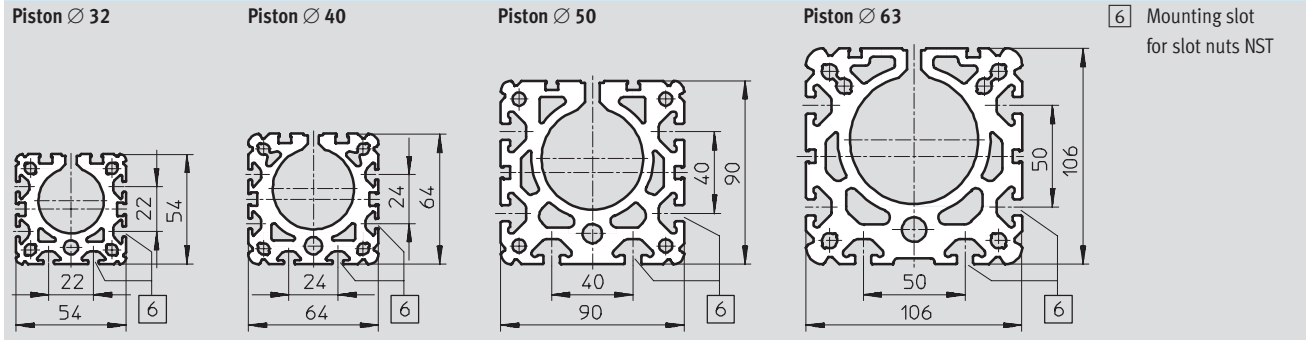

Ø	B1	B2	B3	B4	B5	B6	B11	D2	D3	D4	D5	D6
[mm]			+0.2					Ø	Ø		Ø H10	
32	54	35.8	19	46	21	40	9.5	4.3	5.2	M5	8	M5
40	64	45.7	21	53	28	49	9.5	4.3	6.5	M6	10	M5
50	90	69.2	24	76	44	72	12	6.3	8.5	M8	12	M6
63	106	84.8	24	89	44	83	12	6.3	8.5	M8	12	M8

Ø	EE	H1	H2	H3	H4	H5	H6	H9	H13	J1	J2	J3
[mm]												
32	G $\frac{1}{8}$	72	66	62	23	27	5.8	5	10.3	19	4.2	14
40	G $\frac{1}{4}$	86	78	71.8	26.5	32	7.7	5	12.75	22	5	21
50	G $\frac{1}{4}$	115	106	99	36	45	9.7	21.8	16.6	31.8	6.8	29.3
63	G $\frac{3}{8}$	131	122	115	44.5	53	9.7	-28	30	36	8	31

Ø	J4	J5	J6	J7	J8	L1	L2	L3	L4	L5	L6	L7
[mm]						+1.2/-0.5	+0.3/-0.6					±0.1
32	4.7	15.4	4.2	10.3	20.6	345	125	17	8.5	31	135	50
40	9.1	23	9.1	12.75	25.5	397	150	11.5	11.5	31	171	70
50	6	20.6	6.8	21	21	465	175	14	14	34	206	80
63	14	27	8	25	25	513	200	14	14	34	234	110

Ø	L8	L9	L10	L11	L12	L13	L14	L15	L16	T1	T2	T3	T6
[mm]	±0.1	±0.1											
32	100	30	17	8.5	19	126	27	26	9	13.2	3	7.5	12
40	130	40	10.8	16.5	21	128	29	26	10.8	13.2	4	10.5	12
50	150	50	10.8	18	22.8	149	80	25.2	12	15.2	6	12.5	15
63	190	70	14	24.5	31	147.5	68	16.5	16.5	21.2	6	12.5	20

Linear drives DGPI, integrated displacement encoder

Ordering data – Modular product system



Servopneumatic positioning systems
Cylinders with displacement encoders

1.1

Order code
Mandatory data/Options

- AK Load inverter
- D2 Air connection at both ends
- GK Standard slide

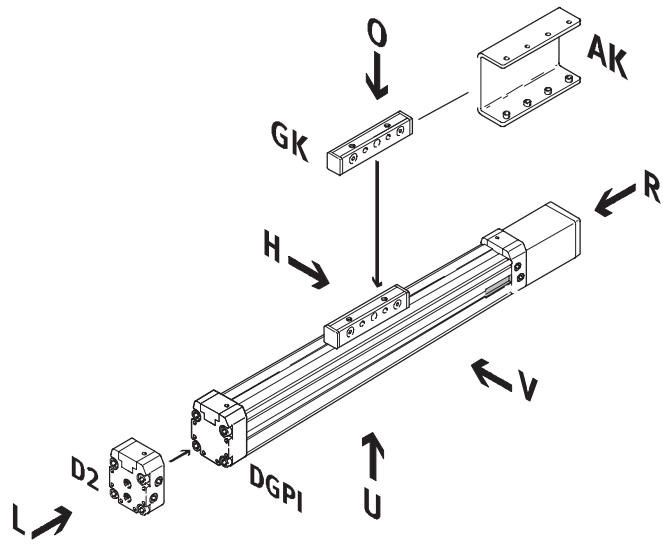

- AV Displacement encoder connection to front
- AH Displacement encoder connection to rear
- AU Displacement encoder connection underneath

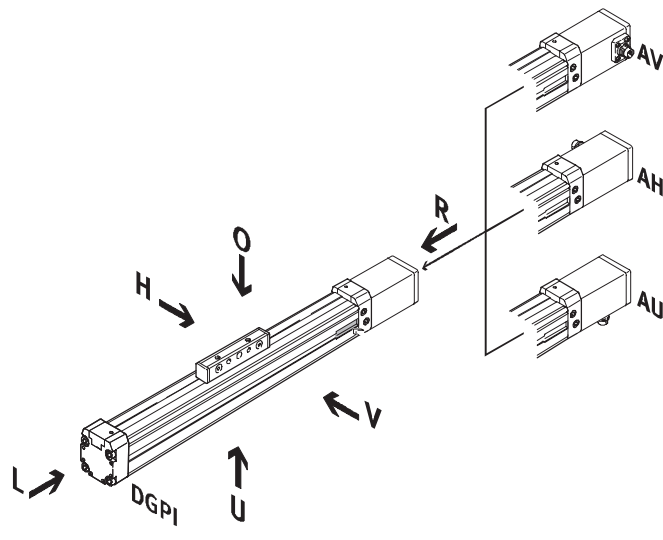

Linear drives DGPI, integrated displacement encoder

Ordering data – Modular product system

FESTO

Order code

Options

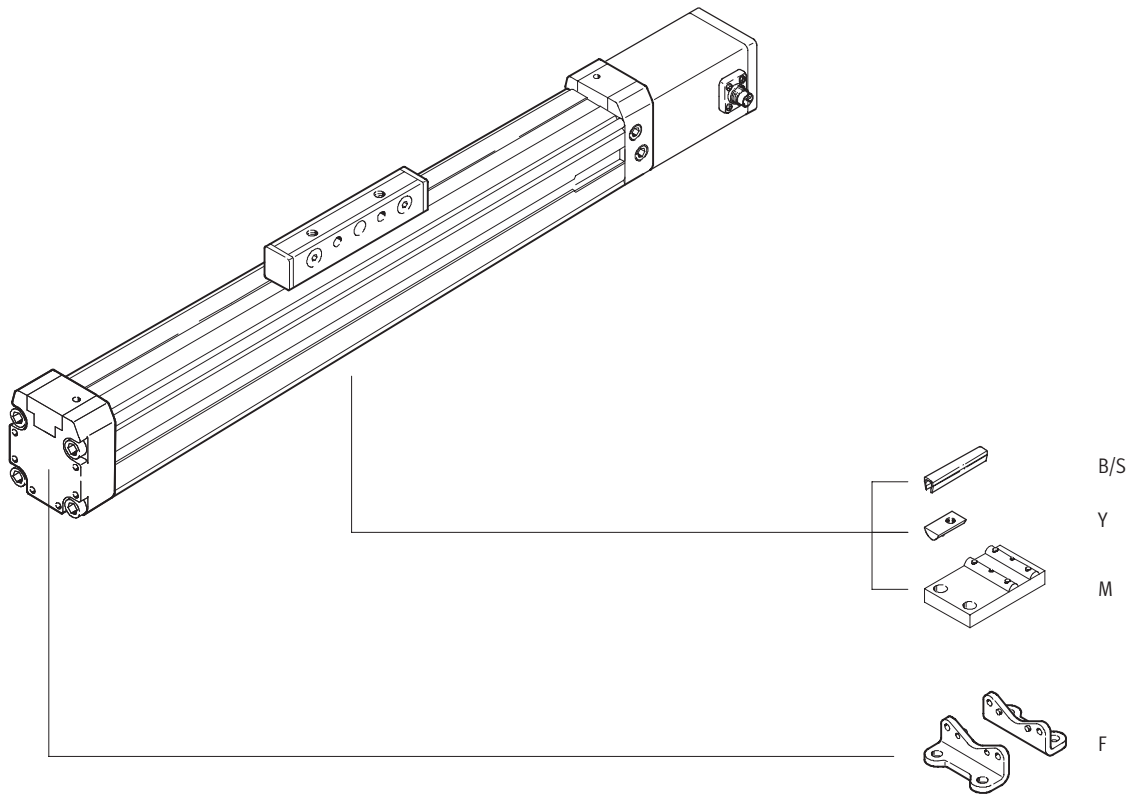

Linear drives DGPI, integrated displacement encoder

Ordering data – Modular product system



M Mandatory data →

Module No.	Drive function	Size	Stroke	Cushioning	Displacement encoder	Basic variant	Connection position for displacement encoder
175 134	DGPI	25	225 ... 2 000	PPV	AIF	GK	AH
175 135		32					AU
175 136		40					AV
175 137		50					
175 138		63					
Ordering example							
175 138	DGPI	- 63	- 750	- PPV	- AIF	- GK	- AV

Ordering table										
Size	25	32	40	50	63	Condi- tions	Code	Enter code		
M Module No.	175 134	175 135	175 136	175 137	175 138					
Drive function	Pneumatic linear drive with integrated displacement encoder							DGPI	DGPI	
Size	25	32	40	50	63		-...			
Stroke [mm]	225, 300, 360, 450, 500, 600, 750, 1 000, 1 250, 1 500, 1 750, 2 000							-...		
Cushioning	Pneumatic cushioning adjustable at both ends							-PPV	-PPV	
Displacement encoder	Temposonic with CAN axis interface							-AIF	-AIF	
Basic variant	Standard piston/slide							-GK	-GK	
Connection position for displacement encoder AIF and compressed air	Connection position for displacement encoder and air supply port, rear							-AH		
	Connection position for displacement encoder and air supply port, underneath							-AU		
	Connection position for displacement encoder and air supply port, front							-AV		

Transfer order code

	DGPI	-		-		-	PPV	-	AIF	-	GK	-	
--	------	---	--	---	--	---	-----	---	-----	---	----	---	--

Linear drives DGPI, integrated displacement encoder

Ordering data – Modular product system

Options					
Driver/Air supply port	Accessories	Slot cover	Slot nut	Central support	Foot mounting
AK D2	ZUB	...S ...B	...Y	...M	...F
- AK	: ZUB	- 2B2S	10Y		F

Ordering table								
Size	25	32	40	50	63	Condi- tions	Code	Enter code
Driver	Load inverter						-AK	
Air supply port	at both ends						-D2	
Accessories	Supplied separately						:ZUB-	:ZUB-
Slot cover, Sensor slot x2, 0.5 m	1 ... 10						...S	
	Mounting slot	1 ... 10					...B	
Slot nut	1 ... 10						...Y	
Central support	1 ... 10						...M	
Foot mounting	1 ... 10						...F	

Transfer order code

- : ZUB -

Linear drives DGPIIL, integrated displacement encoder

Peripherals overview



Servopneumatic positioning systems
Cylinders with displacement encoders

1.1

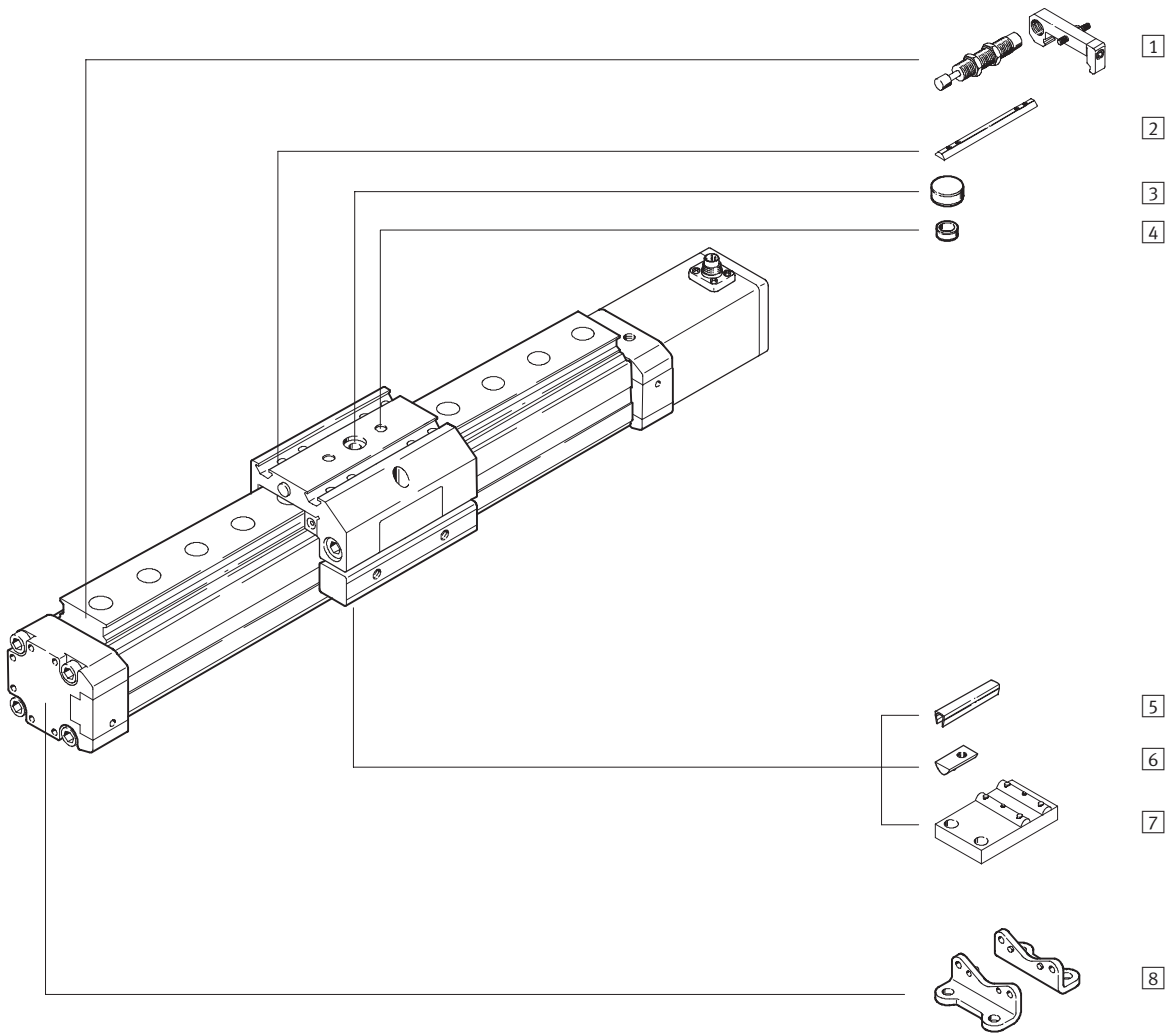

Linear drives DGPII, integrated displacement encoder

Peripherals overview

Variants and accessories		
Type	Brief description	→ Page
1 Shock absorber kit C/E	to avoid damage at the end stop, in the event of malfunctions	5 / 1.1-88
2 Slot nut for slide X	for mounting loads and attachments on the slide	5 / 1.1-89
3 Central mounting Q	for centring loads and attachments on the slide	5 / 1.1-89
4 Centring sleeves Z	for centring loads and attachments on the slide	5 / 1.1-89
5 Slot cover B/S	to protect against the ingress of dirt	5 / 1.1-89
6 Slot nut for mounting slot Y	for mounting attachments	5 / 1.1-89
7 Central support M	to mount the axis	5 / 1.1-86
8 Foot mounting F	to mount the axis	5 / 1.1-86

Linear drives DGPIIL, integrated displacement encoder

Type codes

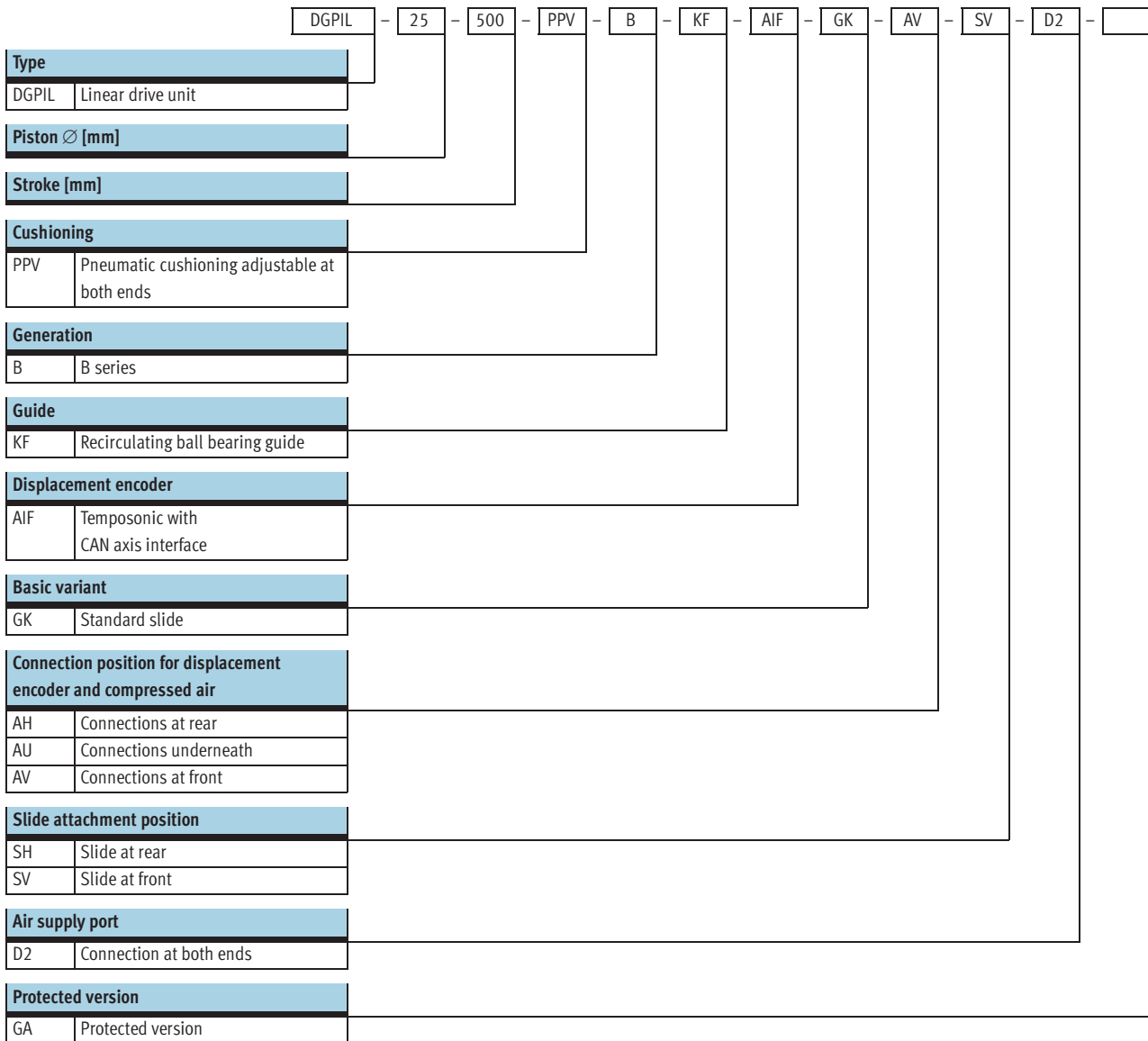

Linear drives DGPIIL, integrated displacement encoder

Type codes

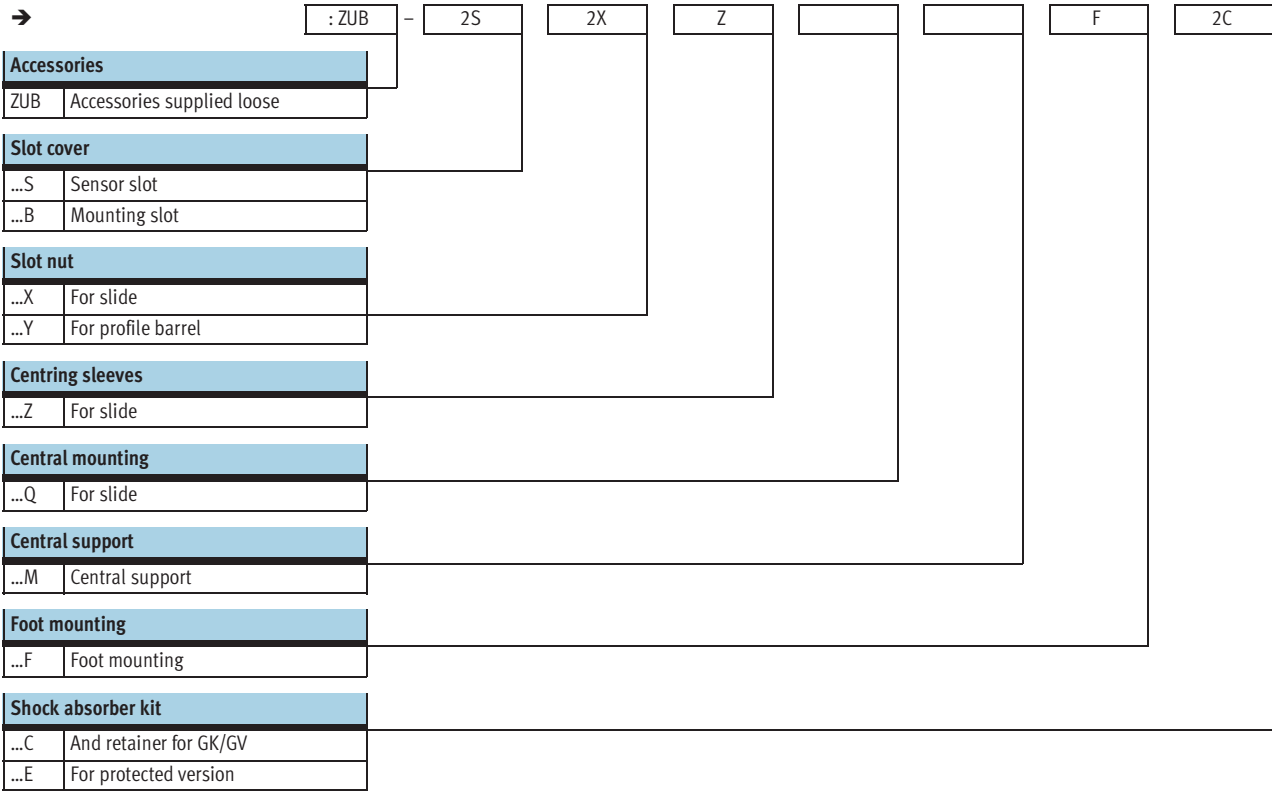



Linear drives DGPII, integrated displacement encoder

Technical data

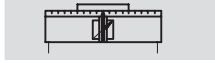

Function



-  - Diameter
25 ... 63 mm
-  - Stroke length
225 ... 2,000 mm

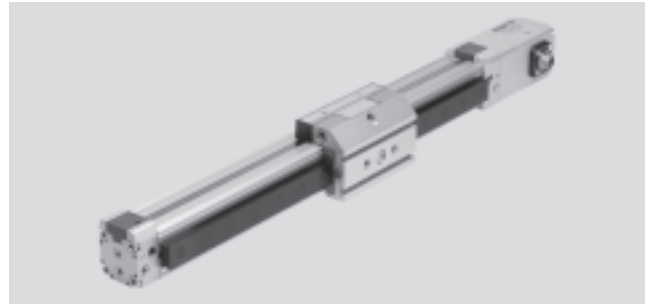

General technical data					
Piston Ø	25	32	40	50	63
Design	Piston				
	Driver				
	Profile barrel				
Mode of operation	Double-acting				
Operating medium ¹⁾	Compressed air, filtered and unlubricated, filter unit 5 µm				
Cushioning	Pneumatic cushioning adjustable at both ends				
Cushioning length [mm]	18	20	30		
Position sensing	Integrated displacement encoder				
Measuring principle	Digital, magnetostrictive, non-contacting, absolute measurement				
Type of mounting	Foot mounting				
Stroke ²⁾³⁾ [mm]	225, 300, 360, 450, 500, 600, 750, 1,000, 1,250, 1,500, 1,750, 2,000				
Protection against torsion/guide	Guide rail with slide				
	Recirculating ball bearing				
Protected version ⁴⁾	Optional				
Pneumatic connection	G1/8		G1/4		G3/8
Electrical connection	6-pin round plug to DIN 45 322				

- 1) The proportional directional control valve MPYE used requires the characteristic values.
- 2) Note stroke reduction in conjunction with SPC200.
- 3) Supply of compressed air to each end of the cylinder (feature D2) is absolutely essential for Soft Stop SPC11 and axis controller SPC200 as of a length of 500 mm.
- 4) Protected from above and the sides against the ingress of particles

Forces [N] and impact energy [Nm]					
Piston Ø	25	32	40	50	63
Theoretical force at 6 bar	295	483	754	1,178	1,870
Max. impact energy at the end positions ¹⁾	0.1	0.2	0.4	0.8	0.8

- 1) Cushioning PPV must be completely open for applications with Soft Stop SPC11 and axis controller SPC200.

Permissible impact velocity:

$$v_{\text{perm.}} = \sqrt{\frac{2 \times E_{\text{perm.}}}{m_{\text{dead}} + m_{\text{load}}}}$$

Maximum permissible load:

$$m_{\text{load}} = \frac{2 \times E_{\text{perm.}}}{v^2} - m_{\text{dead}}$$

-  - Note

This data represents the maximum values which can be achieved. Values fluctuate in practice relative to the size of the effective load. Allowance

must also be made for the limits of the cushioning capacity of the drive and the permissible impact energy.

Linear drives DGPI, integrated displacement encoder

Technical data

Positioning characteristics with axis controller SPC200					
Piston Ø	25	32	40	50	63
Repetition accuracy [mm]	→ 5 / 1.1-46				
Mounting position	Any				
Minimum load, horizontal ¹⁾ [kg]	2	3	5	8	12
Maximum load, horizontal ¹⁾ [kg]	30	45	75	120	180
Minimum load, vertical ¹⁾ [kg]	2	3	5	8	12
Maximum load, vertical ¹⁾ [kg]	10	15	25	40	60
Min. speed of travel [m/s]	0.05				
Max. speed of travel [m/s]	3				
Typ. positioning time, long stroke ²⁾ [s]	0.75/1.20	0.85/1.20	0.75/1.20	0.95/1.25	0.90/1.20
Typ. positioning time, short stroke ³⁾ [s]	0.40/0.60	0.45/0.60	0.40/0.60	0.50/0.65	0.50/0.65
Minimum positioning stroke ⁴⁾ [%]	3				
Stroke reduction ⁵⁾ [mm]	25		35		
Recommended proportional directional control valve	→ 5 / 1.1-90				

- 1) Load = effective load + mass of all moving parts on the drive
- 2) At 6 bar, horizontal mounting position, DGPL-XX-1250, 1000 mm positioning travel at min./max. load
- 3) At 6 bar, horizontal mounting position, DNCM-XX-1250, 100 mm positioning travel at min./max. load
- 4) In relation to the maximum stroke of the drive, but never more than 20 mm.
- 5) The stroke reserve is to be maintained on every side of the drive, the max. positionable stroke is therefore: Stroke – 2x stroke reserve

Positioning characteristics with end position controller SPC11					
Piston Ø	25	32	40	50	63
Repetition accuracy of a mid-position ¹⁾ [mm]	±2				
Mounting position	Any				
Minimum load, horizontal ²⁾ [kg]	2	3	5	8	12
Maximum load, horizontal ²⁾ [kg]	30	45	75	120	180
Minimum load, vertical ²⁾ [kg]	2	3	5	8	12
Maximum load, vertical ²⁾ [kg]	10	15	25	40	60
Travel time [s]	→ Software Tool "SoftStop": www.festo.com/en/engineering				
Recommended proportional directional control valve	→ 5 / 1.1-90				

- 1) In the stroke range from 225 ... 2,000 mm
- 2) Load = effective load + mass of all moving parts on the drive

Operating and environmental conditions					
Piston Ø	25	32	40	50	63
Operating pressure ¹⁾ [bar]	4 ... 8				
Ambient temperature [°C]	-10 ... +60				
Vibration resistance	To DIN/IEC 68 Parts 2 -6, severity level 1				
Continuous shock resistance	To DIN/IEC 68 Parts 2 -27, severity level 1				
CE marking symbol (see conformity declaration)	As per EU EMC directive				
Protection class (displacement encoder)	IP65 to IEC 60 529				

- 1) Only applies for applications with Soft Stop SPC11 and axis controller SPC200.

Linear drives DGPII, integrated displacement encoder

Technical data

FESTO

Weights [g]					
Piston Ø	25	32	40	50	63
Standard slide GK					
Basic weight	2,220	3,320	5,330	10,700	16,870
Additional weight per 10 mm stroke	55	71	99	186	256
Moving load	605	895	1,700	3,000	4,990
Additional weights for protected version GA					
Dirt protection cover	1,690	2,500	4,000	–	–
Additional weight per 10 mm stroke	26	42	65	–	–
Moving load	907	1,350	2,550	–	–

Electrical data, displacement encoder		
Power supply	[V DC]	24 (-15/+25%)
Max. current consumption	[mA]	90
Resolution	[mm]	≤ 0.01
Independent linearity ¹⁾	maximum [%]	0.02
Temperature coefficient	[ppm/°K]	≤ 15
Interface		Digital, CAN with protocol: SPC-AIF

1) Minimum ±50 µm

Materials

Sectional view

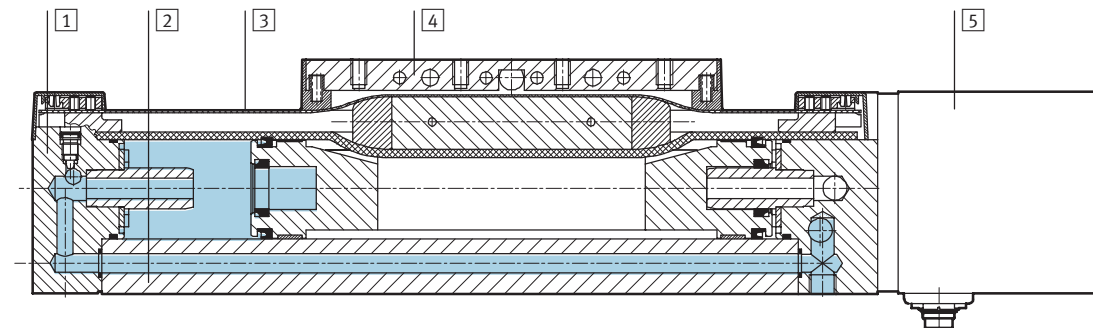

Drive		
1	End cap	Anodised aluminium
2	Profile	Anodised aluminium
3	Cover strip	Steel, corrosion resistant
4	Driver	Anodised aluminium
5	Displacement encoder housing	Anodised aluminium
–	Slide	Anodised aluminium
–	Guide rail	Corrosion resistant steel
–	Seals	Nitrile rubber, polyurethane

-  - Note
Further technical data
➔ Volume 1 (Linear drives DGPII)

Linear drives DGPI, integrated displacement encoder

Technical data



Characteristic load values

The forces and torques specified refer to the centre line of the profile barrel internal diameter.

They must not be exceeded during dynamic operation. Special attention must be paid to the cushioning phase.

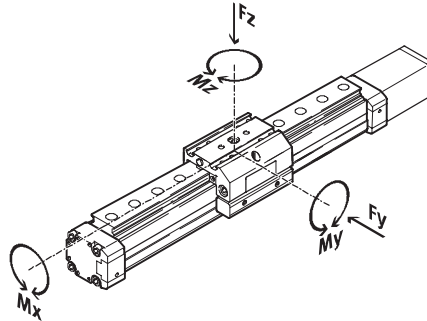

If the drive is subjected to more than two of the indicated forces and torques simultaneously, the following equations must be satisfied in addition to the indicated maximum loads.

$$\frac{F_y}{F_{y_{max}}} + \frac{F_z}{F_{z_{max}}} + \frac{M_x}{M_{x_{max}}} + \frac{M_y}{M_{y_{max}}} + \frac{M_z}{M_{z_{max}}} \leq 1$$

Permissible forces and torques						
Piston Ø		25	32	40	50	63
F _y _{max.}	[N]	3,080	3,080	7,300	7,300	14,050
F _z _{max.}	[N]	3,080	3,080	7,300	7,300	14,050
M _x _{max.}	[Nm]	45	63	170	240	580
M _y _{max.}	[Nm]	85	127	330	460	910
M _z _{max.}	[Nm]	85	127	330	460	910

Maximum permissible support span l as a function of the force F

The axis may need to be supported with central supports MUP in order to limit deflection in the case of large strokes. The following diagrams serve to determine the maximum permissible support span l as a function of the force F.

Force on the surface of the slide

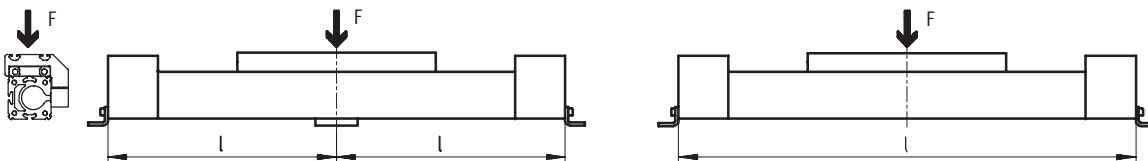

Maximum support span l (without central support) as a function of the force F

Piston Ø 25 ... 40

Piston Ø 50/63

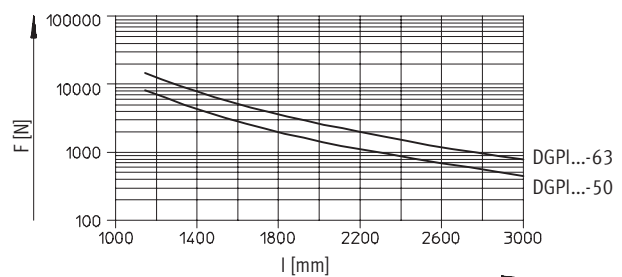
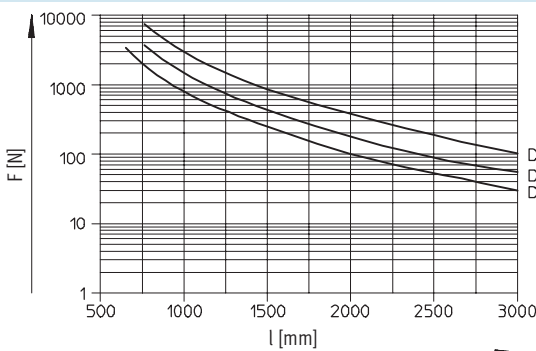

Linear drives DGPII, integrated displacement encoder

Technical data



Dimensions

Download CAD data → www.festo.com/en/engineering

Standard slide GK

Piston $\varnothing 25$

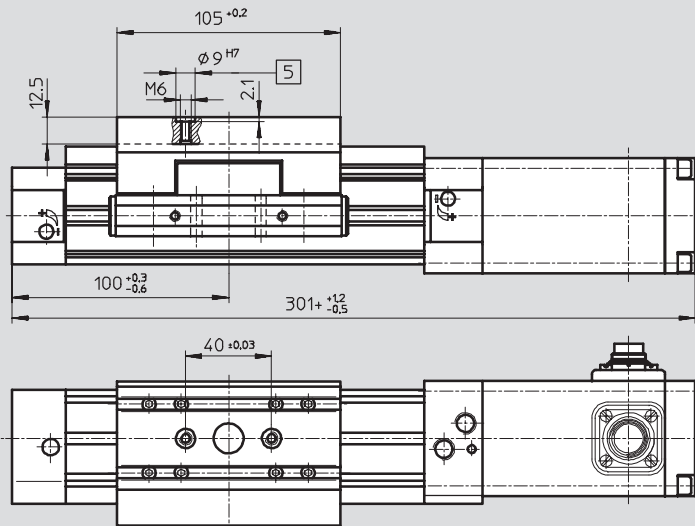
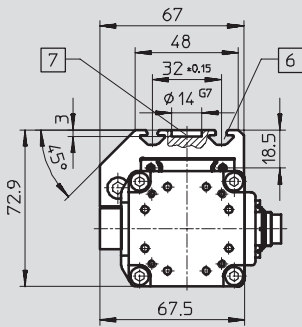

- 5 Hole for centring sleeve ZBH-9
- 6 Mounting slot for slot nut NSTL

- 7 Drilled hole for central mounting SLZZ

+ = plus stroke length

Basic dimensions

→ 5 / 1.1-64

Protected version GA

Piston $\varnothing 25$

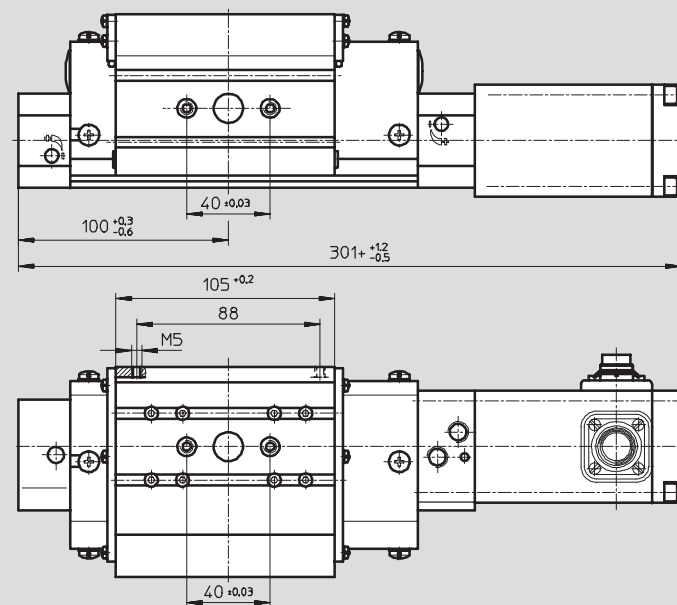
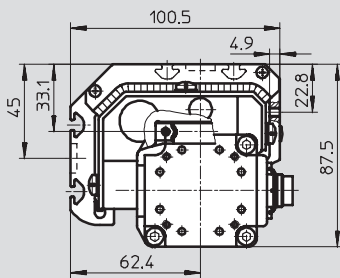

+ = plus stroke length

Basic dimensions

→ 5 / 1.1-64

Linear drives DGPII, integrated displacement encoder

Technical data



Dimensions Download CAD data → www.festo.com/en/engineering

Standard slide GK

Piston \varnothing 32 ... 63

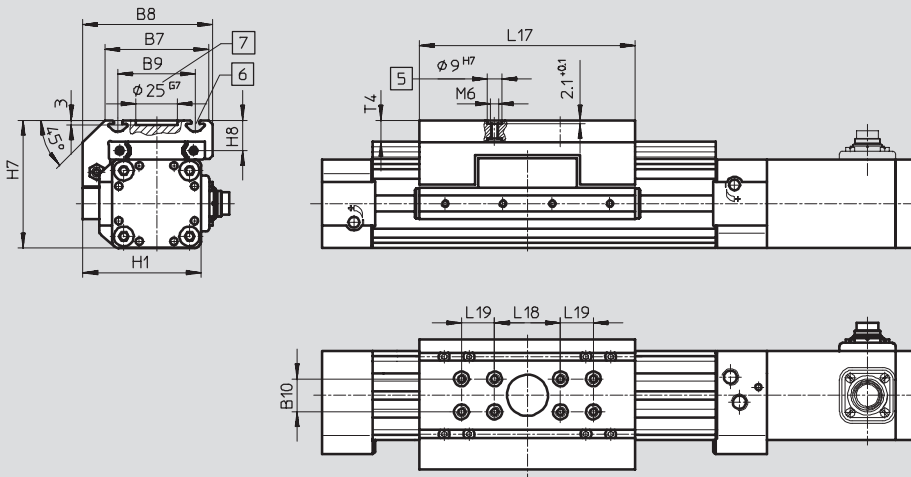

- 5 Hole for centring sleeve ZBH-9
- 6 Mounting slot for slot nut NSTL
- 7 Drilled hole for central mounting SLZZ
- + = plus stroke length

Basic dimensions
→ 5 / 1.1-66

Protected version GA

Piston \varnothing 32/40

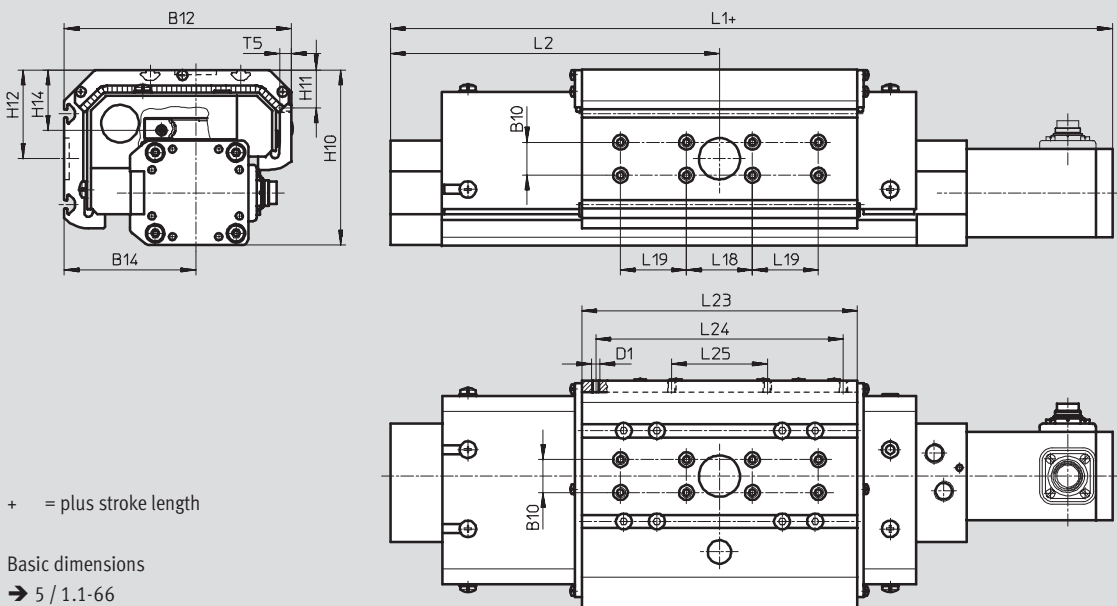

+ = plus stroke length

Basic dimensions
→ 5 / 1.1-66

\varnothing [mm]	B7	B8	B9	B10 ± 0.03	B12	B14	D1	H1	H7	H8	H10
32	63	79	47 ± 0.15	20	112.1	67.6	–	72	77.5	18.5	93.1
40	78.5	96.5	55 ± 0.2	20	137.6	79.6	M5	86	90.5	20	106.6
50	97	122	72 ± 0.2	40	–	–	–	115	122.5	26	–
63	121	142	90 ± 0.25	40	–	–	–	131	144.5	30	–

\varnothing [mm]	H11	H12	H14	L1 $+1.2/-0.5$	L2 $+0.3/-0.6$	L17 $+0.2$	L18 ± 0.03	L19 ± 0.03	L23	L24	L25	T4 max.	T5
32	–	49.5	34.1	345	125	131	40	–	131	–	–	12.5	–
40	23.1	54	36.1	397	150	167	40	40	167	150	58	12.5	7
50	–	–	–	465	175	202	40	40	–	–	–	18.5	–
63	–	–	–	513	200	230	40	40	–	–	–	20.5	–

Linear drives DGPIIL, integrated displacement encoder

Ordering data – Modular product system



Order code

Mandatory data

- KF Recirculating ball bearing guide
- SH Slide at rear
- SV Slide at front
- D2 Air connection at both ends
- GK Standard slide

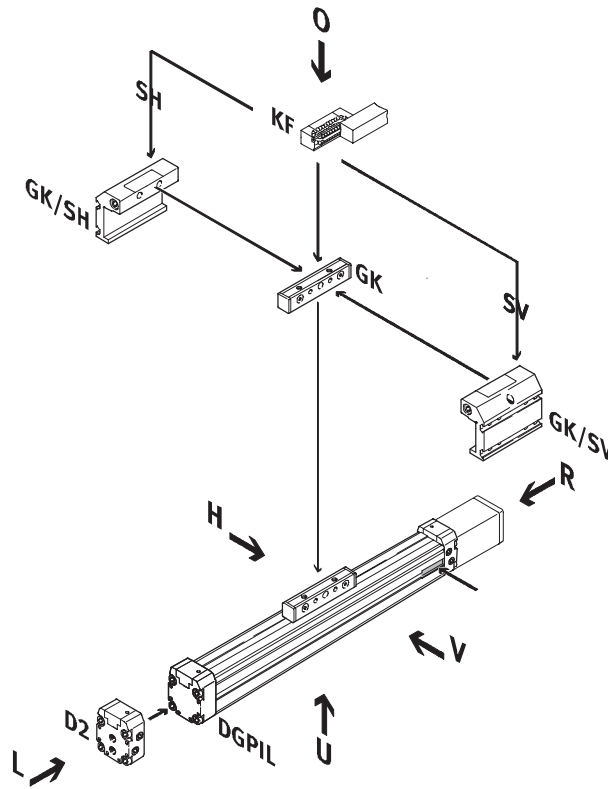

- AV Displacement encoder connection to front
- AH Displacement encoder connection to rear
- AU Displacement encoder connection underneath

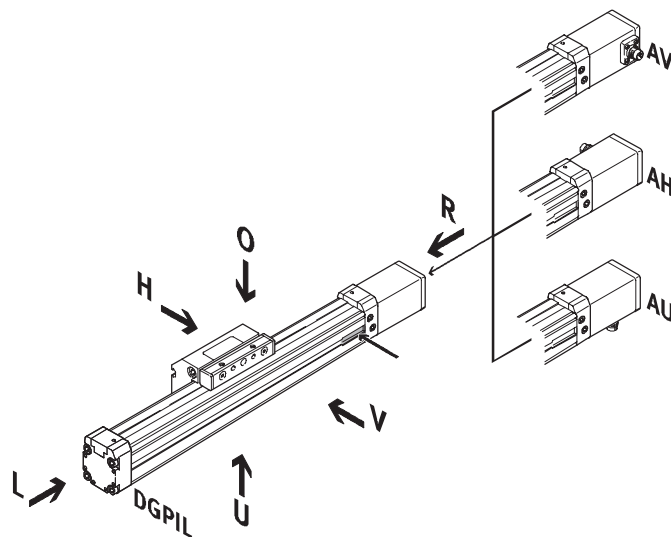

- GA Protected version

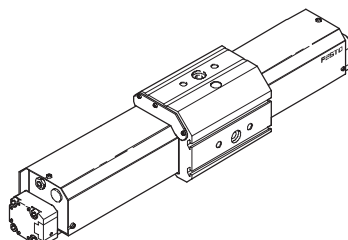

Linear drives DGPIIL, integrated displacement encoder

Ordering data – Modular product system



Order code

Options

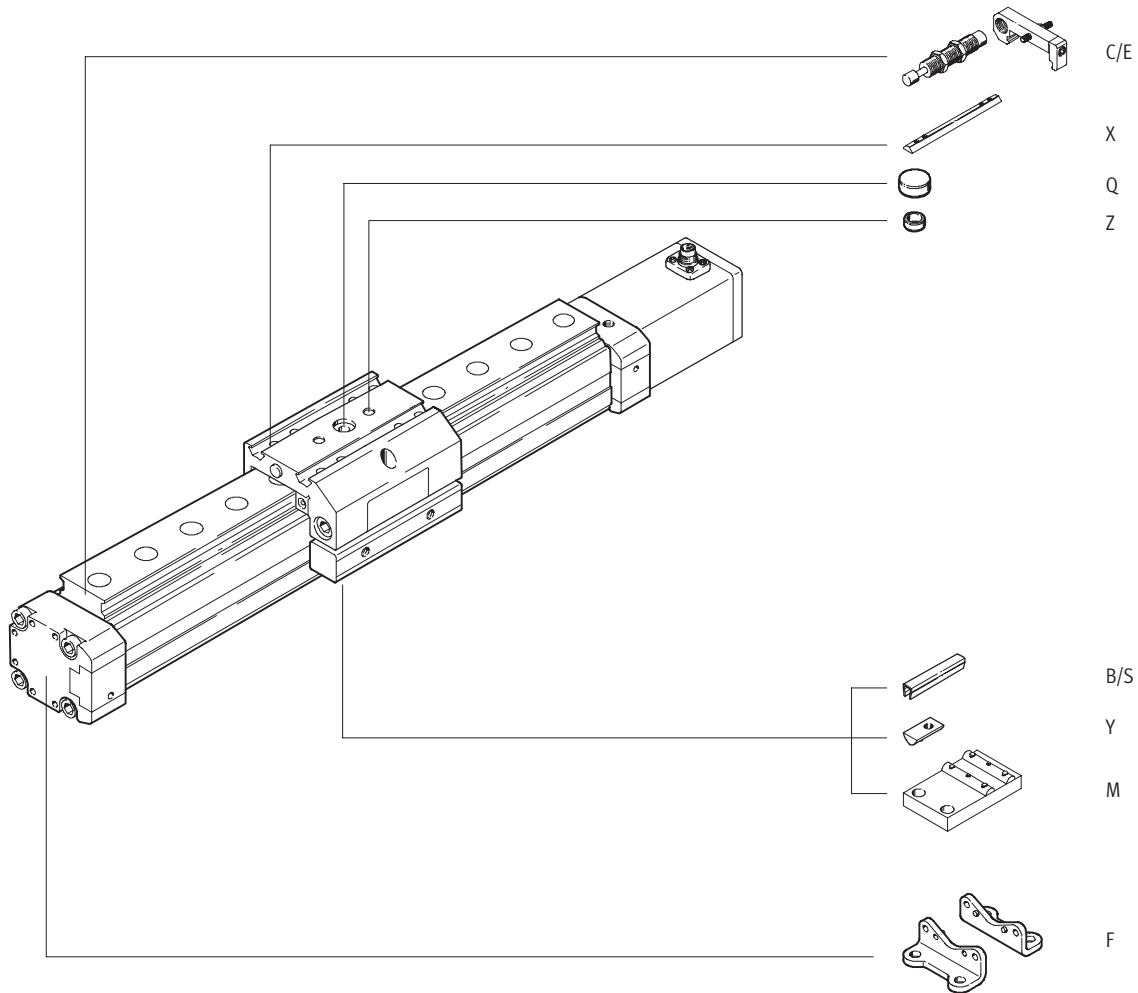

Linear drives DGPII, integrated displacement encoder

Ordering data – Modular product system



M Mandatory data →

Module No.	Drive function	Size	Stroke	Cushioning	Generation	Guide	Displacement encoder	Basic variant	Connection position for displacement encoder	Slide attachment position
175 134	DGPII	25	225 ... 2 000	PPV	B	KF	AIF	GK	AH AU AV	SH SV
175 135		32								
175 136		40								
175 137		50								
175 138		63								
Ordering example										
175 134	DGPII	- 25	- 450	- PPV	- B	- KF	- AIF	- GK	- AU	- SH

Ordering table

Size	25	32	40	50	63	Condi- tions	Code	Enter code	
M Module No.	175 134	175 135	175 136	175 137	175 138				
Drive function	Pneumatic linear drive with integrated displacement encoder and slide							DGPII	DGPII
Size	25	32	40	50	63		-...		
Stroke [mm]	225, 300, 360, 450, 500, 600, 750, 1 000, 1 250, 1 500.1 750, 2 000							-...	
Cushioning	Pneumatic cushioning adjustable at both ends							-PPV	-PPV
Generation	B series							-B	-B
Guide	Recirculating ball bearing guide							-KF	-KF
Displacement encoder	Temposonic with CAN axis interface							-AIF	-AIF
Basic variant	Standard piston/slide							-GK	-GK
Connection position for displacement encoder AIF and compressed air	Connection position for displacement encoder and air supply port, rear							-AH	
	Connection position for displacement encoder and air supply port, underneath							-AU	
	Connection position for displacement encoder and air supply port, front							-AV	
Slide attachment position	Slide at rear							-SH	
	Slide at front							-SV	

Transfer order code

Linear drives DGPII, integrated displacement encoder

Ordering data – Modular product system

0 Options

Air supply port	Protected version	Accessories	Slot cover	Slot nut	Centring sleeve	Central support	Central mounting	Foot mounting	Shock absorber
D2	GA	ZUB	...S ...B	...X ...Y	...Z	...M	...Q	...F	...C ...E
- D2	-	: ZUB	- 2S2B	2X				F	2C

Ordering table		Size	25	32	40	50	63	Condi- tions	Code	Enter code		
↓	Air supply port	at both ends								-D2		
0	Protected version	Protected roller bearing design for harsh environment			-	-	-		-GA			
	Accessories	Supplied separately								:ZUB-	:ZUB-	
	Slot cover, x2, 0.5 m	Sensor slot	1 ... 10								...S	
		Mounting slot	-	1 ... 10								...B
	Slot nut	Slide	1 ... 10								...X	
		Mounting slot	-	1 ... 10								...Y
	Centring sleeve (pack of 10)	10, 20, 30, 40, 50, 60, 70, 80, 90								...Z		
	Central support	1 ... 10								...M		
	Central mounting	1 ... 10								...Q		
	Foot mounting	1 ... 10								...F		
	Shock absorber kit	with retainer, 1-off	1 ... 10						[1]	...C		
			1 ... 10						[2]	...E		

- [1] C Not with protected version GA.
- [2] E Only with protected version GA.

Transfer order code

- [] - [] : ZUB - [] [] [] [] [] [] [] []

Linear drives DGPL/DGPI/DGPIL

Accessories



Foot mounting HP (Order code: F)



Material: Galvanised steel
Free of copper, PTFE and silicone

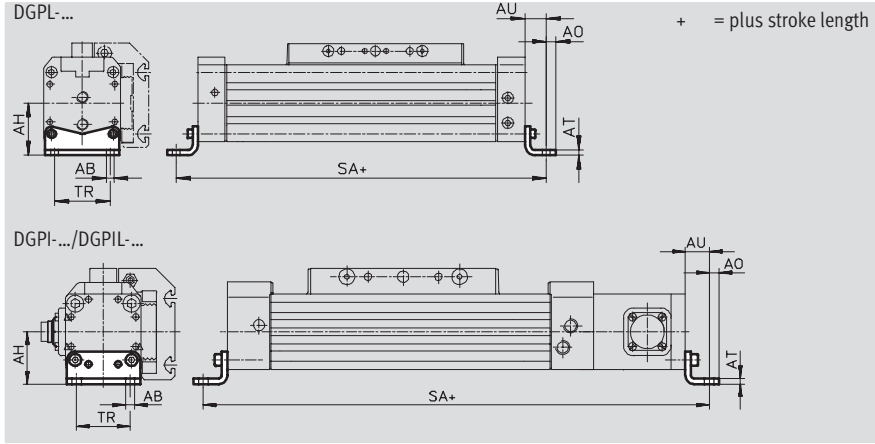

Dimensions and ordering data											
for \varnothing [mm]	AB \varnothing	AH	AO	AT	AU	SA		TR	Weight [g]	Part No.	Type
						DGPL	DGPI(L)				
25	5.5	29.5	6	3	13	226	327	32.5	61	150 731	HP-25
32	6.6	37	7	4	17	284	379	38	117	150 732	HP-32
40	6.6	46	8.5	5	17.5	335	432	45	188	150 733	HP-40
50	9	61	11	6	25	400	515	65	243	150 734	HP-50
63	11	69	13.5	6	28	456	569	75	305	150 735	HP-63

Central support MUP (Order code: M)



Material: Galvanised steel
Free of copper, PTFE and silicone

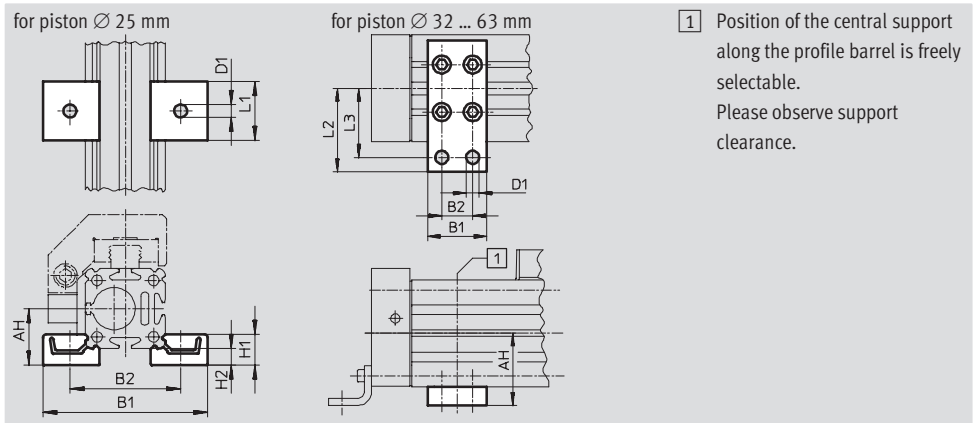

Dimensions and ordering data												
for \varnothing [mm]	AH	B1	B2	D1 \varnothing	H1	H2	L1	L2	L3	Weight [g]	Part No.	Type
32	37	35	22	6.6	-	-	-	41.5	35	89	150 737	MUP-32
40	46	35	22	6.6	-	-	-	47	40	126	150 738	MUP-40
50	61	50	26	11	-	-	-	70	58	241	150 739	MUP-50
63	69	50	26	11	-	-	-	77	65	340	150 800	MUP-63

Linear drives DGPL/DGPI/DGPIL



Accessories

Load inverter AK

for DGPI
(Order code: AK)

Material:
Galvanised steel

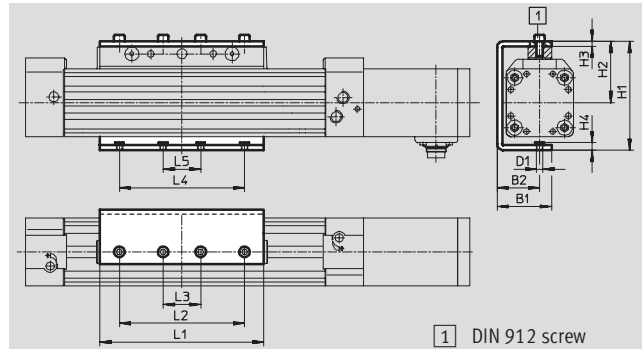
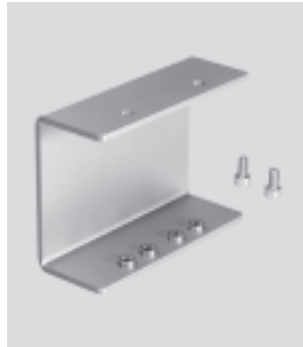

Dimensions and ordering data									
for \varnothing	B1	B2	D1	H1	H2	H3	H4	L1	L2
[mm]									
25	39	29.5	M5	76.1	43.5	3	5	105	–
32	43.5	34	M5	87	49	4	6	131	100
40	50.5	40	M6	104	58	4	8.1	167	130
50	67	55	M8	138.5	75	5	10.5	202	150
63	77	65	M8	156.5	84	6	11.5	230	190

for \varnothing	L3	L4	L5	1	CRC ¹⁾	Weight	Part No.	Type
[mm]						[g]		
25	50	50	20	M5x10	2	380	196 106	AK-25
32	30	100	30	M5x12		690	196 107	AK-32
40	40	130	40	M6x14		1,050	196 108	AK-40
50	50	150	50	M8x16		2,080	196 109	AK-50
63	70	190	70	M8x18		2,820	196 110	AK-63

1) Corrosion resistance class 2 according to Festo standard 940 070

Components requiring moderate corrosion resistance. Externally visible parts with primarily decorative surface requirements which are in direct contact with a surrounding industrial atmosphere or media such as cooling or lubricating agents.

Shock absorber DG-GA

for DGPIL
Protected version GA
(Order code: E)

Material:
Housing: Galvanised steel; piston rod:
high-alloy steel
Seals: Perbunan, polyurethane
Free of copper, PTFE and silicone



Ordering data			
for \varnothing	Weight	Part No.	Type
[mm]	[g]		
25	70	192 875	DG-GA-25-YSR
32	110	192 876	DG-GA-32-YSR
40	140	192 877	DG-GA-40-YSR

Linear drives DGPL/DGPI/DGPIL

Accessories



Servopneumatic positioning systems
Cylinders with displacement encoders

1.1

Shock absorber YSR-...-C

for DGPL/DGPIL

(Order code: C)

Material:

Housing: Galvanised steel; piston rod:

high-alloy steel,

Seals: Perbunan, polyurethane

Free of copper, PTFE and silicone



 Note
Shock absorber YSRW with progressive characteristic
→ Volume 1

Ordering data			
for Ø [mm]	Weight [g]	Part No.	Type
25	70	34 572	YSR-12-12-C
32	70	34 572	YSR-12-12-C
40	140	34 573	YSR-16-20-C
50	140	34 573	YSR-16-20-C
63	240	34 574	YSR-20-25-C

Shock absorber retainer KYP

for DGPL/DGPIL

(Order code: C)

Material:

Retainer: Aluminium

Sleeve: Steel, corrosion resistant

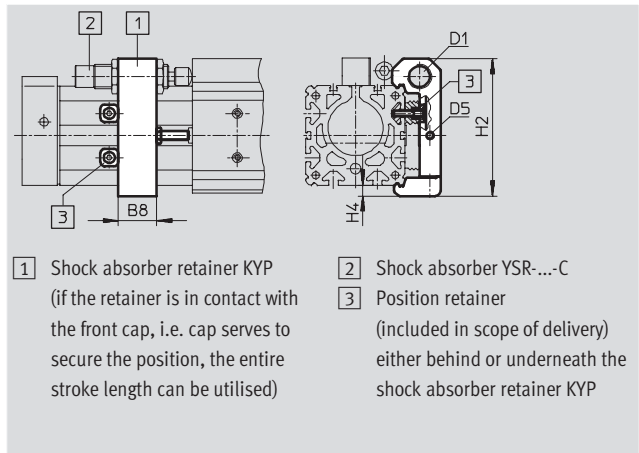
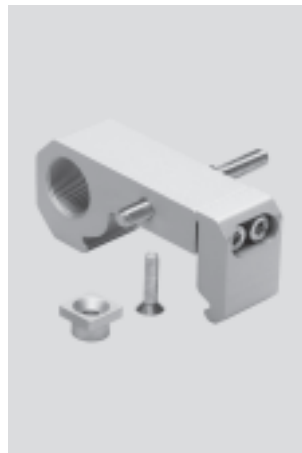



Dimensions and ordering data								
for Ø [mm]	B8	D1	D5	H2	H4	Weight [g]	Part No.	Type
25	19	M16x1	M5	69.5	6	95	158 908	KYP-25
32	25	M16x1	M5	80	8	130	158 909	KYP-32
40	32	M22x1.5	M5	102	8	209	158 910	KYP-40
50	35	M22x1.5	M8	124	10	415	158 911	KYP-50
63	44	M26x1.5	M10	152.5	11.5	609	158 912	KYP-63

Linear drives DGPL/DGPI/DGPIL

Accessories

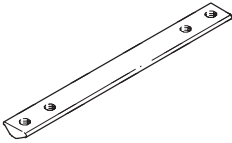
FESTO

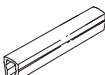
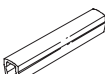
Ordering data				Technical data → Volume 1		
	for Ø [mm]	Remarks	Order code	Part No.	Type	PU ¹⁾
Slot nut NST						
	25	For mounting slot	Y	526 091	NST-HMV-M4	1
	32, 40			150 914	NST-5-M5	1
	50, 63			150 915	NST-8-M6	1
Slot nut NSTL						
	25	For slide	X	158 410	NSTL-25	1
	32			158 411	NSTL-32	1
	40			158 412	NSTL-40	1
	50			158 413	NSTL-50	1
	63			158 414	NSTL-63	1
Centring sleeve ZBH						
	25 ... 63	For slide	Z	150 927	ZBH-9	10
Central mounting SLZZ						
	25	For slide	Q	150 900	SLZZ-16/10	1
	32, 40			150 901	SLZZ-25/16	
	50, 63			150 904	SLZZ-50/40	1
Slot cover ABP						
	32, 40	For mounting slot 0.5 m each	B	151 681	ABP-5	2
	50, 63			151 682	ABP-8	
Slot cover ABP-S						
	25 ... 63	For sensor slot 0.5 m each	S	151 680	ABP-5-S	2

1) Packaging unit quantity

Ordering data – Push-in/threaded fitting				Technical data → Volume 3		
	for Ø [mm]	Remarks	Part No.	Type	PU ¹⁾	
	25, 32	For connecting compressed air tubing		186 098	QS-G¹/₈-8	10
	40, 50			186 099	QS-G¹/₄-8	
	63			186 101	QS-G¹/₄-10	10
				186 100	QS-G³/₈-8	10
				186 102	QS-G³/₈-10	
				186 103	QS-G³/₈-12	

1) Packaging unit quantity

Linear drives DGPL/DGPI/DGPIL

Accessories

FESTO

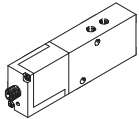
Ordering data – Proportional directional control valve													Technical data → 5 / 1.5-2		
Selection aid															
Application	for Ø [mm]	Stroke [mm]													
		225	300	360	450	500	600	750	1,000	1,250	1,500	1,750	2,000		
horizontal/vertical	For applications with axis controller SPC200														
	25	1/1	1/1	1/1	1/1	1/1	1/1	1/1	1/1	2/2	2/2	2/2	2/2	2/2	
	32	1/1	1/1	2/2	2/2	2/2	2/2	2/2	2/2	2/2	2/2	2/2	2/2	2/2	
	40	1/1	2/2	2/2	2/2	2/2	2/2	2/2	2/2	3/3	3/3	3/3	3/3	3/3	
	50	2/2	2/2	2/2	2/2	2/2	3/3	3/3	3/3	3/3	3/3	3/3	3/3	3/3	
	63	3/3	3/3	3/3	3/3	3/3	3/3	3/3	3/3	3/3	4/4	4/4	4/4	4/4	
	For applications with Soft Stop end position controller SPC11														
	25	1 ¹⁾	1/1	2/1	2/1	2/1	2/2	2/2	2/3	2/3	2/3	2/3	2/3	2/3	
	32	1 ¹⁾	2/1	2/1	2/1	2/1	2/1	3/2	3/3	3/3	3/3	3/3	3/3	3/3	
	40	2/1	2/1	2/1	2/1	2/2	3/3	3/4	3/4	3/4	3/4	3/4	3/4	3/4	
	50	1/1	2/1	2/2	3/2	3/3	4/3	4/4	4/4	4/4	4/4	4/4	4/4	4/4	
	63	2/1	2/2	3/3	3/3	4/4	4/4	4/4	4/4	4/4	4/4	4/4	4/4	4/4	
	Valve	Selection number							Part No.	Type					
		1							151 692	MPYE-5-1/8-LF-010-B					
2							151 693	MPYE-5-1/8-HF-010-B							
3							151 694	MPYE-5-1/4-010-B							
4							151 695	MPYE-5-3/8-010-B							

1) On request

-  - Note

The representation e.g. 2/1 in the columns means:

Selection number 2	Selection number 1
for horizontal application	for vertical application
151 693 MPYE-5-1/8-HF-010-B	151 692 MPYE-5-1/8-LF-010-B

Linear drives DGPL/DGPI/DGPIL

Accessories



Ordering data – Proximity sensor for T-slot, magnetic reed						Technical data → Volume 1	
	Mounting	Electrical connection		Cable length [m]	Part No.	Type	
		Cable	M8 plug				
NO contact							
	Insertable, flush with the cylinder profile	3-wire	–	2.5	150 855	SME-8-K-LED-24	
		–	3-pin	0.3	150 857	SME-8-S-LED-24	
NC contact							
	Insertable from above	3-wire	–	7.5	525 906	SME-8F-DO-24V-K7,5-OE	

Ordering data – Proximity sensor for T-slot, magneto-resistive						Technical data → Volume 1	
	Mounting	Switch output	Electrical connection		Cable length [m]	Part No.	Type
			Cable	M8 plug			
NO contact							
	Insertable, flush with the cylinder profile	PNP	3-pin	–	2.5	175 436	SMT-8-PS-K-LED-24-B
			–	3-pin	0.3	175 484	SMT-8-PS-S-LED-24-B
NC contact							
	Insertable from above	PNP	3-wire	–	7.5	525 911	SMT-8F-PO-24V-K7,5-OE

Ordering data – Plug sockets with cable						Technical data → Volume 1	
	Mounting	Switch output		Connection	Cable length [m]	Part No.	Type
		PNP	NPN				
Straight socket							
	M8 securing nut	■	■	3-pin	2.5	159 420	SIM-M8-3GD-2,5-PU
					5	159 421	SIM-M8-3GD-5-PU
Angled plug socket							
	M8 securing nut	■	■	3-pin	2.5	159 422	SIM-M8-3WD-2,5-PU
					5	159 423	SIM-M8-3WD-5-PU

Swivel module DSMI, integrated displacement encoder

Features



Individual positioning components with swivel module DSMI ...



Proportional directional control valve
MPYE-...
→ 5 / 1.5-2



Soft Stop → 5 / 1.4-2

Positioning technology → 5 / 1.3-2

End position controller
SPC11-POT-LWG



Axis interface
SPC-AIF-POT-LWG



Axis positioning controller
SPC200



Swivel module DSMI, integrated displacement encoder

Features

At a glance

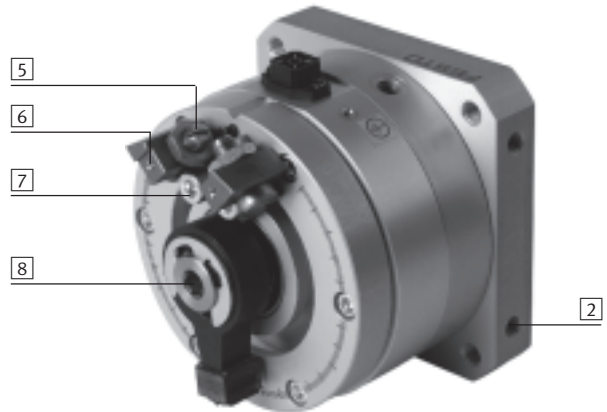
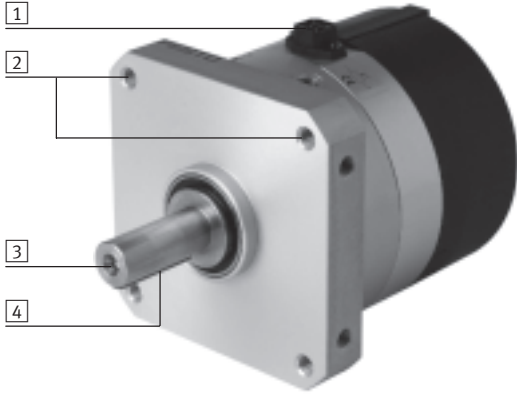

- 1 Connector plug for displacement encoder
- 2 Versatile, integrated attachment facilities
- 3 Customer's own mounting facility on the drive shaft
- 4 Woodruff key
- 5 Fixed stop with fine adjustment of the swivel angle
- 6 Brackets for mounting inductive proximity sensors for contactless position sensing

- 7 Fixed stop can be set at any point within the swivel angle
- 8 Manual operation via internal hexagon socket in the drive shaft.

A female thread is included for attachment of an additional drive shaft by the user.

Mounting options

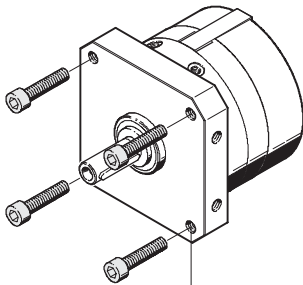

Threaded through-hole

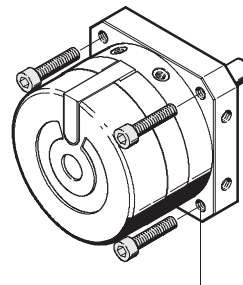

Threaded through-hole

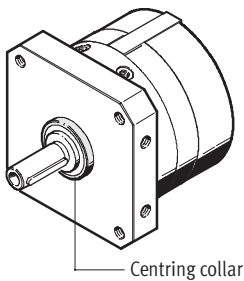

Centring collar

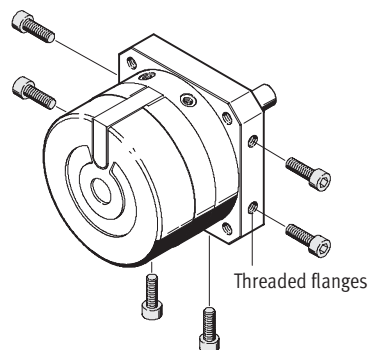

Threaded flanges

Swivel module DSMI, integrated displacement encoder

Application example



Combined linear and swivel motion with Soft Stop SPC11 to reposition small parts

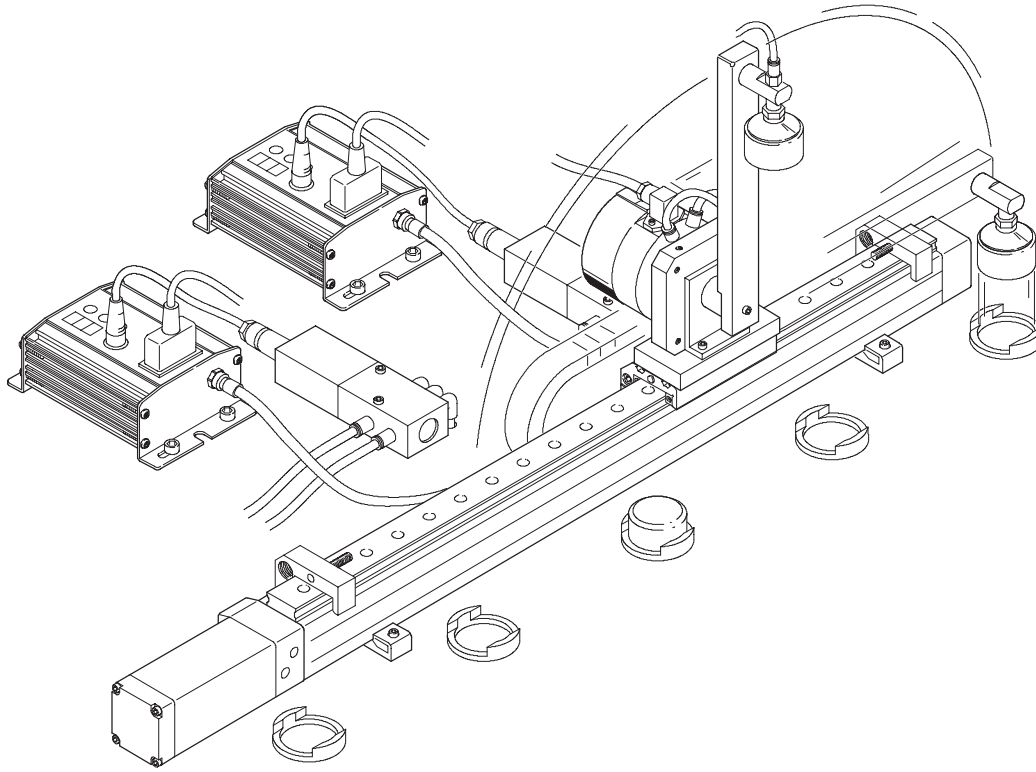

Servopneumatic positioning systems
Cylinders with displacement encoders

1.1

Swivel module DSMI, integrated displacement encoder

Peripherals overview and type code

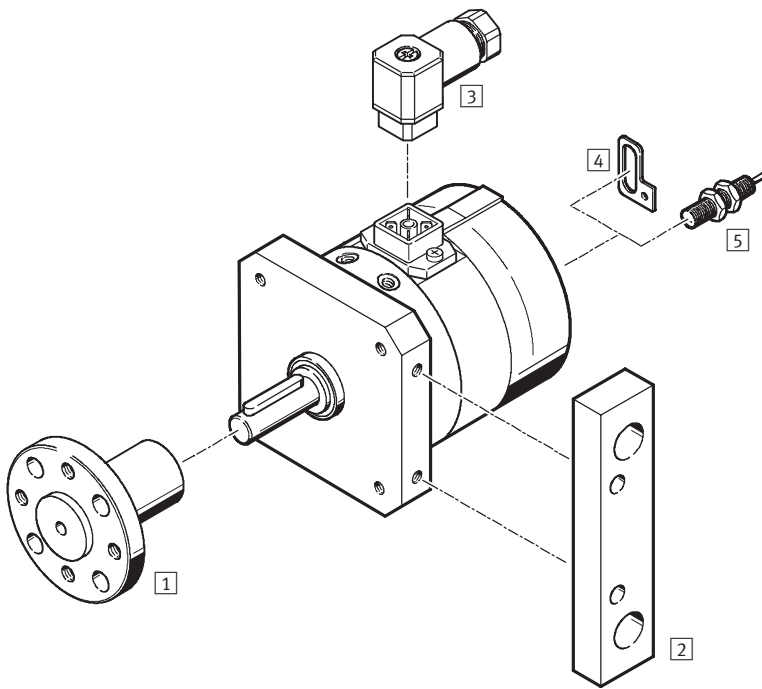

Accessories			
Type	Brief description		→ Page
1	Push-on flange FWSR	for mounting attachments	5 / 1.1-100
2	Mounting plate HSM	adapter plate to mount the drive	5 / 1.1-100
3	Plug socket SD	to connect the displacement encoder, is part of the end position controller SPC11 and the axis controller SPC200	5 / 1.1-101
4	Sensor mounting kit WSM	bracket to mount the inductive proximity sensor	5 / 1.1-100
5	Proximity sensors SIEN	for additional sensing of the swivel position (see SIEN-M8)	Volume 4

		DSMI	-	25	-	270
Type						
DSMI	Standard cylinder					
Piston Ø [mm]						
Swivel angle [mm]						

Swivel module DSML, integrated displacement encoder

Technical data

FESTO

Function

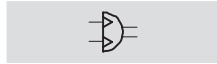

- - Diameter
25 and 40 mm
- - Force
5, 20 Nm



General technical data		
Piston \varnothing	25	40
Design	Rotary vane Drive shaft	
Mode of operation	Double-acting	
Operating medium ¹⁾	Compressed air, filtered and unlubricated, filter unit 5 μ m	
Cushioning	Non-adjustable at either end	
Cushioning angle	[°] 1.1 ... 1.9	1.4 ... 2.1
Position sensing	Integrated angular displacement encoder Proximity sensor ²⁾	
Measuring principle (angular displacement encoder)	Analogue with rotary encoder, contacting with absolute measurements	
Type of mounting	Direct mounting	
Shaft	Running on ball bearings	
End stops	Adjustable	
Max. swivel angle ³⁾	[°] 272	
Pneumatic connection	M5	G $\frac{1}{8}$
Electrical connection	4-pin plug, \square 16, DIN 45 322	

- 1) The proportional directional control valve MPYE used requires the characteristic values.
- 2) Can be ordered as an option.
- 3) Note stroke reduction in conjunction with SPC200.

Torque and impact energy [Nm]		
Piston \varnothing	25	40
Torque ¹⁾	5	20
Max. impact energy at end positions	0.05	0.1

- 1) Theoretical values, calculated at 6 bar.

Permitted forces and torques on the drive shaft		
Piston \varnothing	25	40
Max. perm. radial load	[N] 120	350
Max. perm. axial load	[N] 50	120
Max. perm. mass moment of inertia ¹⁾	[10 ⁻⁴ kg m ²] 1.1	2.4
Max. operating frequency ²⁾	[Hz] 2	

- 1) Unthrottled, for applications with Soft Stop SPC11 and axis controller SPC200 → 5 / 1.1-97
- 2) For max. permissible mass moment of inertia and a stroke of 270°.

- - Note

Further technical data
→ Volume 1 (Swivel module DSM)

Swivel module DSMI, integrated displacement encoder

FESTO

Technical data

Positioning characteristics with axis controller SPC200		
Piston Ø	25	40
Repetition accuracy	[°]	±0.3
Mounting position	Any	
Min. mass moment of inertia, horizontal ¹⁾	[10 ⁻⁴ kg m ²]	15
Max. mass moment of inertia, horizontal ¹⁾	[10 ⁻⁴ kg m ²]	300
Min. mass moment of inertia, vertical ²⁾	[10 ⁻⁴ kg m ²]	15
Max. mass moment of inertia, vertical ²⁾	[10 ⁻⁴ kg m ²]	300
Min. speed of travel	[°/s]	50
Max. speed of travel	[°/s]	2,000
Typ. positioning time, long stroke ³⁾	[s]	0.35/0.60
Typ. positioning time, short stroke ⁴⁾	[s]	0.15/0.25
Minimum positioning stroke	[°]	5
Max. swivel stroke ⁵⁾	[°]	260
Recommended proportional directional control valve	MPYE-5-M5-010-B	MPYE-5-1/8-LF-010-B

- 1) Must not change during the movement, but may be outside the centre of gravity.
- 2) Must not change during the movement, must act at the centre of gravity.
- 3) At 6 bar, vertical mounting position, 260° positioning angle at min./max. mass moment of inertia.
- 4) At 6 bar, vertical mounting position, 15° positioning angle at min./max. mass moment of inertia.
- 5) A stroke reduction of 5° on both sides must be observed.

Positioning characteristics with Soft Stop end position controller SPC11		
Piston Ø	25	40
End-position repetition accuracy ¹⁾	[°]	< 0.2
Repetition accuracy of a mid-position	[°]	< ±2
Mounting position	horizontal	
Cushioning ²⁾	No	
Min. mass moment of inertia, horizontal ³⁾	[10 ⁻⁴ kg m ²]	15
Max. mass moment of inertia, horizontal ³⁾	[10 ⁻⁴ kg m ²]	300
Minimum swivel stroke	[°]	15
Recommended proportional directional control valve	MPYE-5-M5-010-B	MPYE-5-1/8-LF-010-B

- 1) When using the DSMI limit stops.
- 2) The cushioning pad on the stop lever must be removed for applications with Soft Stop. The stop lever may not swivel to the end stop at too great a speed as this could destroy the swivel module.

Operating and environmental conditions		
Piston Ø	25	40
Operating pressure ¹⁾	[bar]	4 ... 8
Ambient temperature ²⁾	[°C]	-10 ... +60
Vibration resistance	To DIN/IEC 68 Parts 2 - 6, severity level 2	
Continuous shock resistance	To DIN/IEC 68 Parts 2 - 27, severity level 2	
CE marking symbol (see conformity declaration)	Según directiva UE para CEM	
Protection class	IP65 to IEC 60 529	
Corrosion resistance class CRC ³⁾	1	

- 1) Only applies for applications with the Soft Stop end position controller SPC11 and axis controller SPC200.
- 2) Note operating range of proximity sensors
- 3) Corrosion resistance class 1 according to Festo standard 940 070
Components requiring low corrosion resistance. Transport and storage protection.

Swivel module DSMI, integrated displacement encoder

Technical data



Weights			
Piston Ø		25	40
DSMI	[g]	1,060	3,750

Electrical data, displacement encoder			
Piston Ø		25	40
Power supply ¹⁾	[V DC]	10	
Max. current consumption	[mA]	4	
Wiper current	recommended	[µA]	< 1
	maximum ²⁾	[mA]	10
Connection resistance	[kΩ]	5	
Connection resistance tolerance	[%]	±20	
Angle resolution	[°]	0.1	
Independent linearity	[%]	0.25	
Temperature coefficient	[ppm/°K]	≤ 10	
Interface		Analogue	

- 1) Stabilised power supply is recommended, max. 42 VDC permissible.
- 2) Only permissible in the short-term in the event of a fault.

Materials

Sectional view

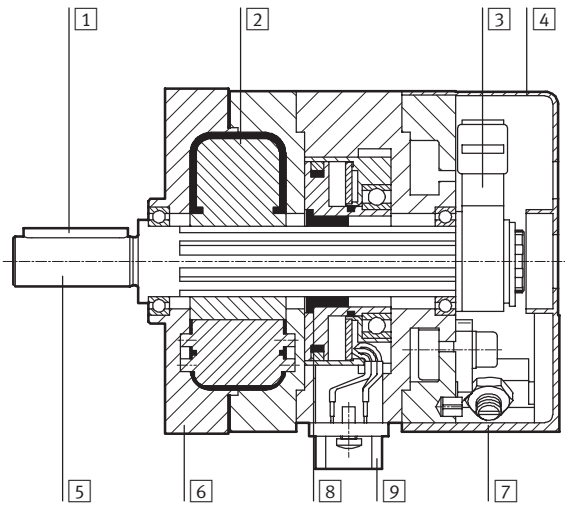

Cylinder/Displacement encoder		
Cylinder		
1	Woodruff key	Steel
2	Rotary vane	GRP
3	Stop lever	Anodised aluminium
4	Cap	GRP
5	Shaft	Nickel plated steel
6	Housing	Anodised aluminium
7	Fixed stop/Screw	Galvanised steel
	Note on material	Free of copper, PTFE and silicone
Displacement encoder		
8	Coupling	Polyurethane
9	Housing	Anodised aluminium
-	Resistor element	Conductive plastic

Swivel module DSMI, integrated displacement encoder

Technical data



Dimensions Download CAD data → www.festo.com/en/engineering

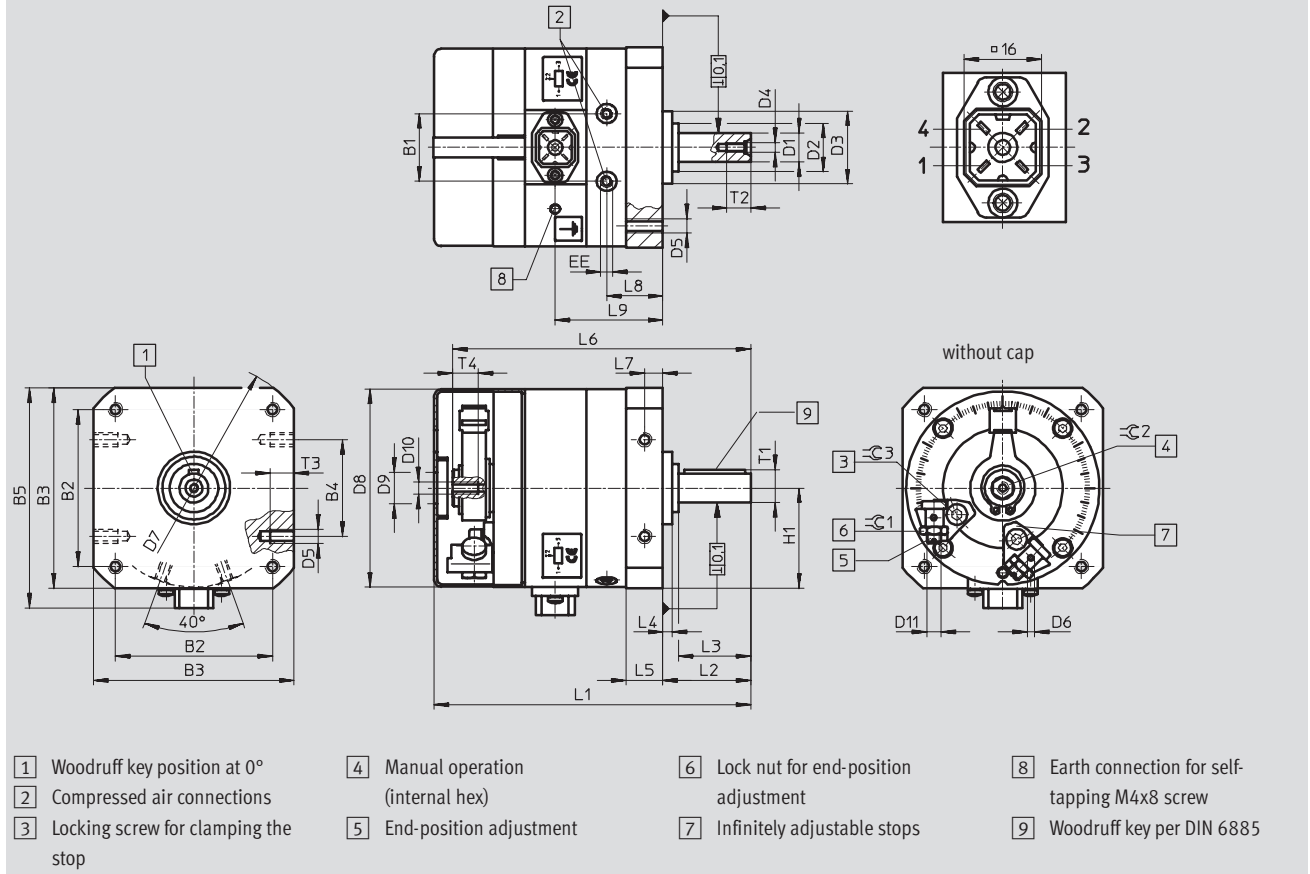

∅	B1	B2	B3	B4	B5	D1	D2	D3	D4	D5	D6	D7
[mm]	±0.5	±0.3	±0.3		±1	g7 ∅	∅	∅				∅
25	28	65	83	40±0.2	91	12	20-0.3	30	M4	M6	M3	106±0.3
40	43.8	105	130	80±0.3	139	20	36-0.4	52	M5	M10	M3	168±0.5

∅	D8	D9	D10	D11	EE	H1	L1	L2	L3	L4	L5	L6
[mm]	∅	∅ +0.5				±0.2			±0.2	±0.4	+0.2 -0.4	±0.8
25	82±0.2	13	M5	M6x0.5	M5	41.5	131±1.2	36.5+0.6/-0.7	30	4	15.2	123
40	128±0.3	23.5	M6	M10x1	G1/8	65	200±1.5	62+0.7/-0.8	50	8	23.7	184

∅	L7	L8	L9	T1	T2	T3	T4	∠C1	∠C2	∠C3	Woodruff key to DIN 6885
[mm]	±0.2		±1	max.	+2	±0.2			D12		
25	7.5	23.5	44.5	13.5	10	10	10	10	8	4	A4x4x25
40	12	36	64.5	22.5	16	15	10	17	10	8	A6x6x45

Ordering data			
Type	Swivel angle [°]	Part No.	Type
DSMI-25-270	270	192 270	DSMI-25-270
DSMI-40-270	270	192 271	DSMI-40-270

Swivel module DSML, integrated displacement encoder

Accessories



Push-on flange FWSR

Material:
Anodised aluminium
Free of copper, PTFE and silicone

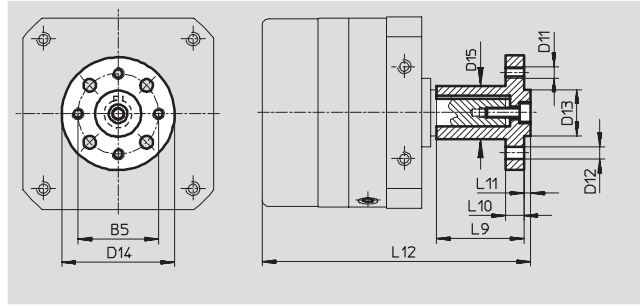

Dimensions and ordering data													
for \varnothing	B5	D11	D12	D13	D14	D15	L9	L10	L11	L12	Weight	Part No.	Type
[mm]			\varnothing H13	\varnothing g7	\varnothing	\varnothing					[g]		
25	35	M5	5,5	20	50	23	38	8	3	116,5	68	13 240	FWSR-25
40	54	M8	9	36	70	38	60	11	5	186,5	240	14 656	FWSR-40

Mounting plate HSM

Material:
Anodised aluminium
Free of copper, PTFE and silicone

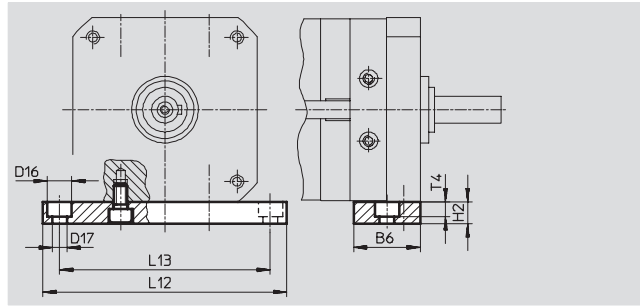
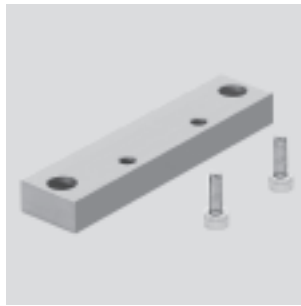

Dimensions and ordering data										
for \varnothing	B6	D16	D17	H2	L12	L13	T4	Weight	Part No.	Type
[mm]		\varnothing	\varnothing					[g]		
25	30	11	6,6	10	110	95	6,8	94	165 573	HSM-25
40	45	18	11	20	180	155	11	459	165 575	HSM-40

Ordering data – Mounting kit			
	for \varnothing	Remarks	Part No. Type
	[mm]		
	25	For inductive proximity sensors SIEN	161 043 WSM-25-JM5
	40		161 045 WSM-40-JM8

Swivel module DSMI, integrated displacement encoder

Accessories

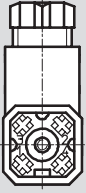

Ordering data – Push-in/threaded fitting			Technical data → Volume 3	
	for Ø [mm]	Remarks	Part No.	Type
	25	For connecting compressed air tubing with standard O.D.	153 306	QSM-M5-6
	40		186 096	QS-G-1/8-6

Ordering data – Plug socket				
	PIN	Pin allocations	Designation	Part No. Type
	1	Power supply	Plug socket	194 332 SD-4-WD-7
	2	Signal		
	3	0 V		
	4	PE (yellow), screen		

 Note
Recommended proximity sensor
→ Type SIEN-M8, Volume 4

