

Ball valves VAPB/QH-DR



- Ball valves and ball valve drive units
- Connecting thread to DIN 2999 or DIN ISO 228-1
- Mounting flange to ISO 5211
- Length to DIN 3202-M3
- Corrosion and acid resistant designs
- Blow-out proof shaft mounted from inside

Ball valves VAPB

Product range overview

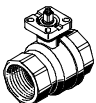
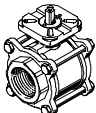
Type	Design	Type	Connecting thread ¹⁾	Nominal size [mm]	Flanged connection to ISO 5211	Max. operating pressure [bar]	→ Page
Ball valve	Brass						
		VAPB	Rp1/4	15	F03	40	7 / 2.2-4
			Rp3/8	15	F03	40	
			Rp1/2	15	F03	40	
			Rp3/4	20	F03	40	
			Rp1	25	F03	40	
			Rp1 1/4	32	F0405	40	
			Rp1 1/2	40	F0405	25	
			Rp2	50	F05	25	
	Rp2 1/2	63	F07	25			
	Stainless steel, corrosion-resistant						
		VAPB-...-CR	Rp1/4	15	F0304	63	7 / 2.2-7
			Rp3/8	15	F0304		
			Rp1/2	15	F0304		
			Rp3/4	20	F0304		
			Rp1	25	F0405		
			Rp1 1/4	32	F0405		
			Rp1 1/2	40	F0507		
			Rp2	50	F0507		
			Rp2 1/2	63	F0710		
Rp3			80	F0710			
Rp4	100	F1012					

1) Cylindrical barrel with female thread to DIN 2999

Ball valves VAPB

Type code

VAPB – 1 1/2 – F – 63 – F0507 – CR

Type	
VAPB	Ball valve for process automation

Connection size to DIN 2999	
1/4	Barrel with female thread Rp1/4
3/8	Barrel with female thread Rp3/8
1/2	Barrel with female thread Rp1/2
3/4	Barrel with female thread Rp3/4
1	Barrel with female thread Rp1
1 1/4	Barrel with female thread Rp1 1/4
1 1/2	Barrel with female thread Rp1 1/2
2	Barrel with female thread Rp2
2 1/2	Barrel with female thread Rp2 1/2
3	Barrel with female thread Rp3
4	Barrel with female thread Rp4

Type of barrel connection	
F	Female thread

Max. operating pressure	
25	25 bar
40	40 bar
63	63 bar



Flange connection to ISO 5211	
F03	1 circular arrangement of holes with \varnothing 36 mm
F0304	2 circular arrangements of holes with \varnothing 36 and 42 mm
F0405	2 circular arrangements of holes with \varnothing 42 and 50 mm
F05	1 circular arrangement of holes with \varnothing 50 mm
F0507	2 circular arrangements of holes with \varnothing 50 and 70 mm
F07	1 circular arrangement of holes with \varnothing 70 mm
F0710	2 circular arrangements of holes with \varnothing 70 and 102 mm
F1012	2 circular arrangements of holes with \varnothing 102 and 125 mm

Material	
	Brass
CR	Corrosion resistant cast steel

Ball valves VAPB

Technical data – Brass design



-  Connecting thread
Rp $\frac{1}{4}$... Rp $\frac{2}{2}$
-  Flow rate Kv
5.9 ... 535 m³/min

- Connecting thread to DIN 2999
- Mounting flange to ISO 5211
- Length to DIN 3202-M3
- Blow-out proof shaft mounted from inside
- Centering attachment for simple automation
- O-ring seal for use with a vacuum



General technical data									
Connecting thread	Rp $\frac{1}{4}$	Rp $\frac{3}{8}$	Rp $\frac{1}{2}$	Rp $\frac{3}{4}$	Rp1	Rp1 $\frac{1}{4}$	Rp1 $\frac{1}{2}$	Rp2	Rp2 $\frac{1}{2}$
Valve function	2/2								
Design	Ball valve								
Sealing principle	Soft								
Actuation type	Pneumatic								
Direction of flow	Reversible								
Type of mounting	In-line installation								
Mounting position	Any								
Nominal size [mm]	15	15	15	20	25	32	40	50	63
Flow rate Kv [m ³ /min]	5.9	9.4	17	41	70	121	200	292	535
Product weight [g]	500	500	400	500	800	1,300	1,900	3,100	3,100

Operating and environmental conditions									
Connecting thread	Rp $\frac{1}{4}$	Rp $\frac{3}{8}$	Rp $\frac{1}{2}$	Rp $\frac{3}{4}$	Rp1	Rp1 $\frac{1}{4}$	Rp1 $\frac{1}{2}$	Rp2	Rp2 $\frac{1}{2}$
Operating medium	Compressed air, water, neutral gasses, neutral fluids Vacuum								
Nominal operating pressure [bar]	40	40	40	40	40	40	25	25	25
Temperature of medium [°C]	-20 ... +150								
Corrosion resistance class CRC ¹⁾	1								

1) Corrosion resistance class 1 according to Festo standard 940 070
Components requiring low corrosion resistance. Transport and storage protection. Parts that do not have primarily decorative surface requirements, e.g. in internal areas that are not visible or behind covers.

Materials		
Housing	Brass	
Ball	Brass	
Seals	Housing	Polytetrafluoroethylene, fibreglass reinforced
	Shaft	Fluorocarbon rubber

Torque ¹⁾ [Nm]									
Connecting thread	Rp $\frac{1}{4}$	Rp $\frac{3}{8}$	Rp $\frac{1}{2}$	Rp $\frac{3}{4}$	Rp1	Rp1 $\frac{1}{4}$	Rp1 $\frac{1}{2}$	Rp2	Rp2 $\frac{1}{2}$
$\Delta p = 0$ bar	3.1	3.1	3.1	4.6	6.5	10.8	13.5	20	30
$\Delta p = 10$ bar	3.5	3.5	3.5	5.1	7.2	11.9	14.9	22	33
$\Delta p = pN$	5	5	5	6	8.5	15	19	29	45

1) Required torque for the actuation of the ball valve

Ball valves VAPB

Technical data – Brass design

Permissible operating pressure as a function of the temperature of the medium

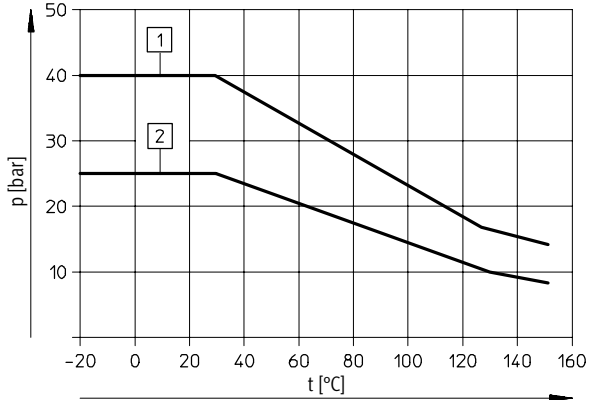

- 1 Rp1/2 ... Rp1 1/4
- 2 Rp1 1/2 ... Rp2 1/2

Dimensions

Download CAD data → www.festo.com/en/engineering

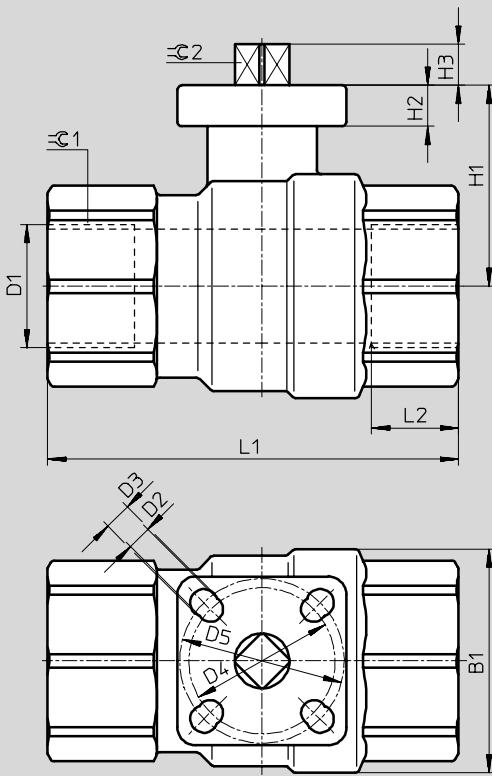

Connecting thread D1 ¹⁾	B1	D2 ∅	D3 ∅	D4 ∅	D5 ∅	H1	H2	H3	L1	L2	C1	C2
Rp1/4	33	5.5	-	36	-	38	9	9	75	15	26	9
Rp3/8	33	5.5	-	36	-	38	9	9	75	15	26	9
Rp1/2	33	5.5	-	36	-	38	9	9	75	15	26	9
Rp3/4	41	5.5	-	36	-	41	9	9	80	16	32	9
Rp1	50	5.5	-	36	-	44	9	9	90	19	41	9
Rp1 1/4	61	5.5	6.5	42	50	55	10	11	110	21	50	11
Rp1 1/2	74	5.5	6.5	42	50	62	10	11	120	21	55	11
Rp2	89	6.5	-	50	-	73	12	14	140	25	70	14
Rp2 1/2	106	8.5	-	70	-	83	10	15.5	143	24.2	83	14

1) Cylindrical barrel with female thread to DIN 2999

Ball valves VAPB

Technical data – Brass design

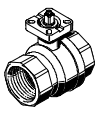

Ordering data			
Design	Connecting thread ¹⁾	Part No.	Type
	Rp1/4	534 302	VAPB-1/4-F-40-F03
	Rp3/8	534 303	VAPB-3/8-F-40-F03
	Rp1/2	534 304	VAPB-1/2-F-40-F03
	Rp3/4	534 305	VAPB-3/4-F-40-F03
	Rp1	534 306	VAPB-1-F-40-F03
	Rp1 1/4	534 307	VAPB-1 1/4-F-40-F0405
	Rp1 1/2	534 308	VAPB-1 1/2-F-25-F0405
	Rp2	534 309	VAPB-2-F-25-F05
	Rp2 1/2	534 310	VAPB-2 1/2-F-25-F07

1) Cylindrical barrel with female thread to DIN 2999

Ball valves VAPB

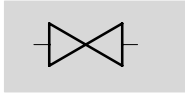
Technical data – Stainless steel design



-  Connecting thread
Rp $\frac{1}{4}$... Rp4
-  Flow rate Kv
16 ... 1 414 m³/min

- Connecting thread to DIN 2999
- Mounting flange to ISO 5211
- Length to DIN 3202-M3
- Blow-out proof shaft mounted from inside
- Centering attachment for simple automation
- O-ring seal for use with a vacuum



General technical data											
Connecting thread	Rp $\frac{1}{4}$	Rp $\frac{3}{8}$	Rp $\frac{1}{2}$	Rp $\frac{3}{4}$	Rp1	Rp1 $\frac{1}{4}$	Rp1 $\frac{1}{2}$	Rp2	Rp2 $\frac{1}{2}$	Rp3	Rp4
Valve function	2/2										
Design	Ball valve										
Sealing principle	Soft										
Actuation type	Pneumatic										
Direction of flow	Reversible										
Type of mounting	In-line installation										
Mounting position	Any										
Nominal size [mm]	10	12	16	20	25	32	40	50	63	80	100
Flow rate Kv [m ³ /min]	16	21	35	46	72	105	170	275	507	905	1 414
Product weight [g]	200	200	700	800	1,200	1,900	2,800	4,500	9,200	13,900	22,300

Operating and environmental conditions											
Connecting thread	Rp $\frac{1}{4}$	Rp $\frac{3}{8}$	Rp $\frac{1}{2}$	Rp $\frac{3}{4}$	Rp1	Rp1 $\frac{1}{4}$	Rp1 $\frac{1}{2}$	Rp2	Rp2 $\frac{1}{2}$	Rp3	Rp4
Operating medium	Compressed air, water, neutral gasses, neutral fluids Vacuum										
Nominal operating pressure [bar]	63										
Temperature of medium [°C]	-20 ... +150										
Corrosion resistance class CRC ¹⁾	3										

1) Corrosion resistance class 3 according to Festo standard 940 070
Components requiring higher corrosion resistance. External visible parts in direct contact with industrial atmospheres or media such as solvents and cleaning agents, with a predominantly functional requirement for the surface.

Materials		
Housing	Stainless steel	
Ball	Stainless steel	
Seals	Housing	Polytetrafluoroethylene, fibreglass reinforced
	Shaft	Fluorocarbon rubber

Torque ¹⁾ [Nm]											
Connecting thread	Rp $\frac{1}{4}$	Rp $\frac{3}{8}$	Rp $\frac{1}{2}$	Rp $\frac{3}{4}$	Rp1	Rp1 $\frac{1}{4}$	Rp1 $\frac{1}{2}$	Rp2	Rp2 $\frac{1}{2}$	Rp3	Rp4
$\Delta p = 0$ bar	5	5	7	9	13	20	28	37	49	54	62
$\Delta p = 10$ bar	5.5	5.5	7.7	9.9	14.3	22	30.8	40.7	53.9	59.4	68.2
$\Delta p = pN$	7	7	10	13	17	28	43	64	69	78	95

1) Required torque for the actuation of the ball valve

Ball valves VAPB

Technical data – Stainless steel design

Permissible operating pressure as a function of the temperature of the medium

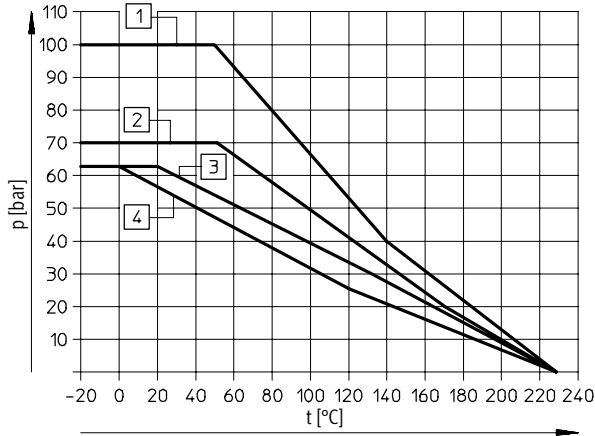

- 1 Rp1/4 ... Rp1
- 2 Rp1 1/4 ... Rp1 1/2
- 3 Rp2 ... Rp2 1/2
- 4 Rp3..., Rp4

Dimensions

Download CAD data → www.festo.com/en/engineering

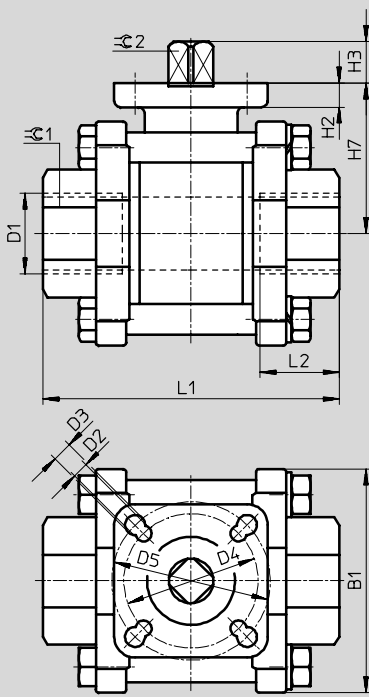

Connecting thread D1 ¹⁾	B1	D2 Ø	D3 Ø	D4 Ø	D5 Ø	H1	H2	H3	L1	L2	≙C1	≙C2
Rp1/4	48	5.5	5.5	36	42	40	9	7	65	14	19	9
Rp3/8	48	5.5	5.5	36	42	40	9	7	65	14	24	9
Rp1/2	50	5.5	5.5	36	42	40	9	7	75	20	29	9
Rp3/4	54	5.5	5.5	36	42	44	9	9	80	19	35	9
Rp1	61	5.5	6.5	42	50	52	10	12	90	21	41	11
Rp1 1/4	72	5.5	6.5	42	50	58	10	12	110	23	50	11
Rp1 1/2	82	6.5	8.5	50	70	68	13	16	120	25	58	14
Rp2	99	6.5	8.5	50	70	77	13	16	140	28	73	14
Rp2 1/2	126	8.5	10.5	70	102	98	13	19	185	38	90	17
Rp3	186	8.5	10.5	70	102	110	13	19	205	42	105	17
Rp4	224	10.5	12.5	102	125	138	20	24	240	42	135	22

1) Cylindrical barrel with female thread to DIN 2999

Ball valves VAPB

Technical data – Stainless steel design

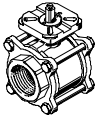
Ordering data			
Design	Connecting thread ¹⁾	Part No.	Type
	Rp $\frac{1}{4}$	534 311	VAPB- $\frac{1}{4}$ -F-63-F0304-CR
	Rp $\frac{3}{8}$	534 312	VAPB- $\frac{3}{8}$ -F-63-F0304-CR
	Rp $\frac{1}{2}$	534 313	VAPB- $\frac{1}{2}$ -F-63-F0304-CR
	Rp $\frac{3}{4}$	534 314	VAPB- $\frac{3}{4}$ -F-63-F0304-CR
	Rp1	534 315	VAPB-1-F-63-F0405-CR
	Rp1 $\frac{1}{4}$	534 316	VAPB-1 $\frac{1}{4}$ -F-63-F0405-CR
	Rp1 $\frac{1}{2}$	534 317	VAPB-1 $\frac{1}{2}$ -F-63-F0507-CR
	Rp2	534 318	VAPB-2-F-63-F0507-CR
	Rp2 $\frac{1}{2}$	534 319	VAPB-2 $\frac{1}{2}$ -F-63-F0710-CR
	Rp3	534 320	VAPB-3-F-63-F0710-CR
	Rp4	534 321	VAPB-4-F-63-F1012-CR

1) Cylindrical barrel with female thread to DIN 2999

Ball valve drive units QH-DR/CRQH-DR

Features



FESTO

Standard directional control valves
Ball valves

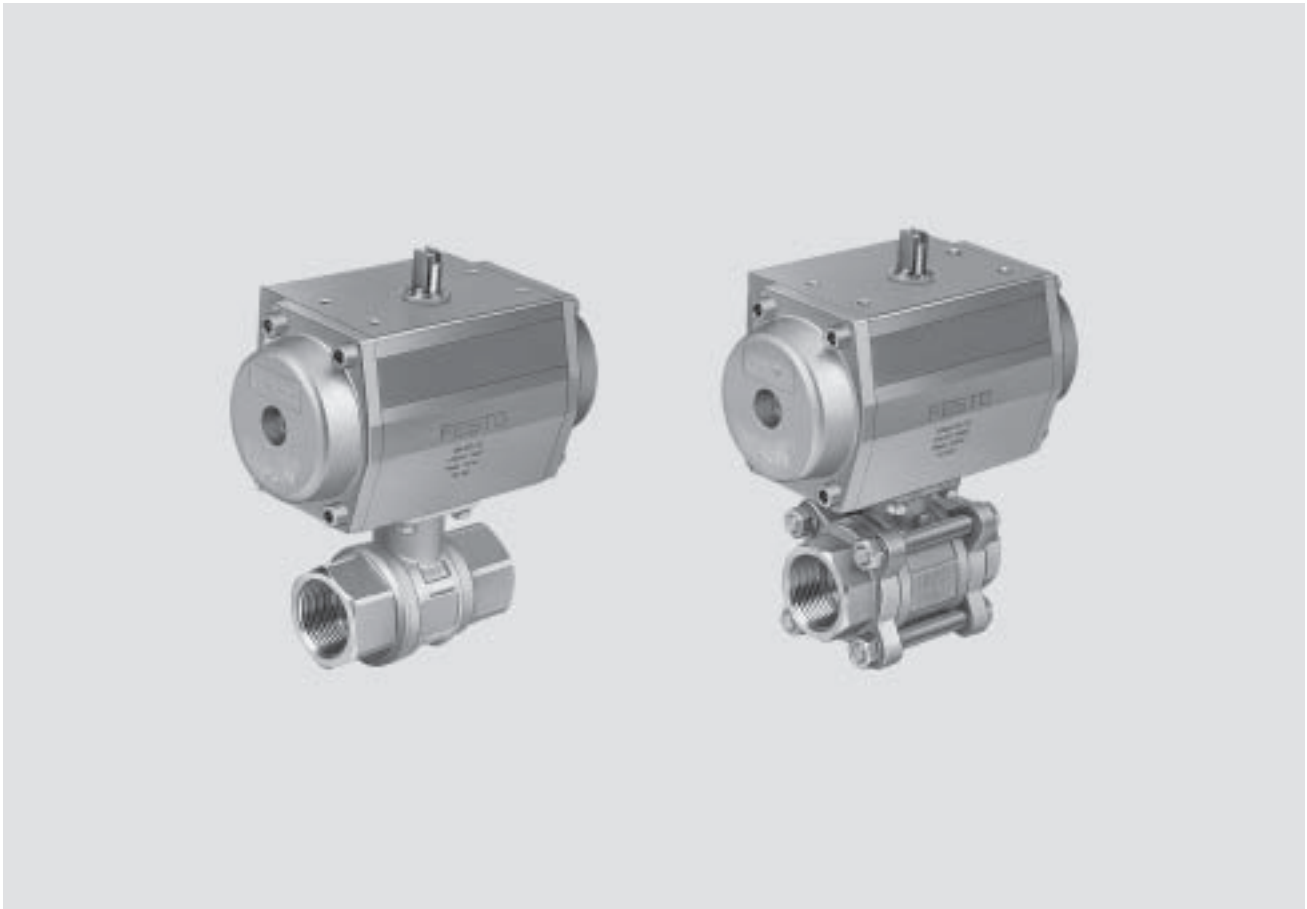
2.2



QH-DR
CRQH-DR

-  - Connecting thread
G $\frac{1}{4}$... G2
-  - Flow rate Kv
5.1 ... 191 m³/min
- Corrosion and acid-resistant
version CRQH-DR
- Namur port pattern

Flow is entirely closed or opened in both directions via the ball valve drive unit.

The unit is a combination of a pneumatic rotary drive and a ball valve.

A 5/2-way solenoid valve with Namur port pattern can be directly connected to the drive unit.

The drive unit can also be actuated with a separate valve.

Valves with Namur port pattern
→ 7 / 2.1-6

Pneumatic, electric or inductive end-position sensing is possible with corresponding limit switch attachments. The attachments can be screwed directly to the drive unit.

Ball valve drive units QH-DR/CRQH-DR

Product range overview

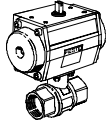
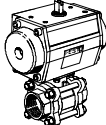
Type	Design	Type	Connecting thread ¹⁾	Nominal size [mm]	Max. operating pressure [bar]	→ Page	
Ball valve drive unit		QH-DR	G1/4	8	63	7 / 2.2-13	
			G3/8	10	63		
			G1/2	15	63		
			G3/4	20	50		
			G1	25	50		
			G1 1/4	32	40		
			G1 1/2	40	40		
			G2	50	40		
	Corrosion resistant						
		CRQH-DR	G1/4	9	63	7 / 2.2-17	
			G3/8	12			
			G1/2	16			
			G3/4	20			
			G1	25			
			G1 1/4	32			
G1 1/2			40				
G2			50				

1) Cylindrical barrel with female thread to DIN ISO 228-1

Ball valve drive units QH-DR/CRQH-DR

Type codes



CRQH-DR – 1½ – B



Type	
QH-DR	Ball valve drive unit for process automation
CRQH-DR	Ball valve drive unit for process automation, corrosion-resistant

Connection size to DIN ISO 228-1	
¼	Barrel with female thread G¼
⅜	Barrel with female thread G⅜
½	Barrel with female thread G½
¾	Barrel with female thread G¾
1	Barrel with female thread G1
1¼	Barrel with female thread G1¼
1½	Barrel with female thread G1½
2	Barrel with female thread G2

Generation	
B	Series B

Ball valve drive units QH-DR

Technical data

-  - Connecting thread
G $\frac{1}{4}$... G2
-  - Flow rate Kv
5.1 ... 191 m³/min

- Combination of a ball valve and pneumatic rotary drive
- Connecting thread to DIN ISO 228-1
- Solenoid valves with the Namur port pattern can be connected directly
- Limit switch attachments can be screwed directly onto the drive unit



General technical data								
Connecting thread	G $\frac{1}{4}$	G $\frac{3}{8}$	G $\frac{1}{2}$	G $\frac{3}{4}$	G1	G1 $\frac{1}{4}$	G1 $\frac{1}{2}$	G2
Valve function	2/2 way							
Design	Ball valve							
Sealing principle	Soft							
Actuation type	Pneumatic							
Direction of flow	Reversible							
Type of mounting	In-line installation							
Mounting position	Any							
Nominal size [mm]	8	10	15	20	25	32	40	50
Flow rate Kv [m ³ /min]	5.1	6.8	16	26	47	70	145	191
Product weight [g]	1,150	1,200	1,250	1,450	2,300	2,850	4,650	5,650

Operating and environmental conditions								
Connecting thread	G $\frac{1}{4}$	G $\frac{3}{8}$	G $\frac{1}{2}$	G $\frac{3}{4}$	G1	G1 $\frac{1}{4}$	G1 $\frac{1}{2}$	G2
Operating medium	Compressed air, water, neutral gasses, neutral fluids Vacuum							
Pilot medium	Filtered compressed air, lubricated or unlubricated							
Nominal operating pressure [bar]	63	63	63	50	50	40	40	32
Temperature of medium [°C]	-40 ... +200 (for water 4 ... 60)							
Ambient temperature [°C]	-20 ... +85							
Corrosion resistance class CRC ¹⁾	1							

1) Corrosion resistance class 1 according to Festo standard 940 070
Components requiring low corrosion resistance. Transport and storage protection. Parts that do not have primarily decorative surface requirements, e.g. in internal areas that are not visible or behind covers.

Materials		
Ball valve		
Housing	Brass	
Ball	Brass	
Seals	Housing	Polytetrafluoroethylene, fibreglass reinforced
	Shaft	Polytetrafluoroethylene, fibreglass reinforced
Rotary drive		
Housing	Hard anodised aluminium	
Shaft	Nickel plated steel	

Ball valve drive units QH-DR

Technical data



Minimum pilot pressure as a function of operating pressure¹⁾

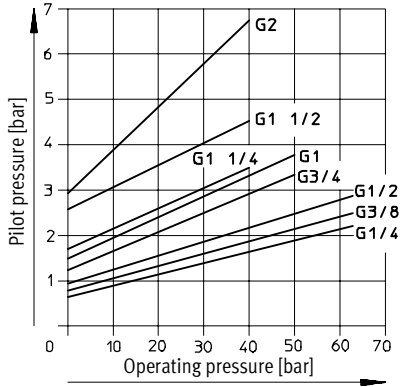

Response times as a function of operating pressure²⁾

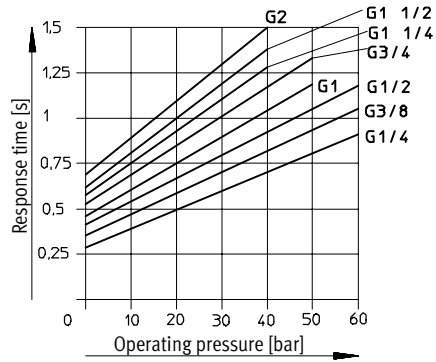

- 1) For lubricating media. Values may be as much as 30% higher for non-lubricating media.
- 2) Guide values at 5 bar pilot pressure

Permissible operating pressure as a function of the temperature of the medium

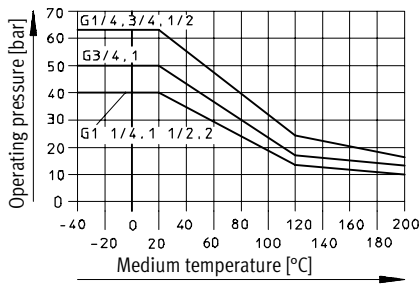

Ball valve drive units QH-DR

Technical data



Dimensions and ordering data Download CAD data → www.festo.com/en/engineering

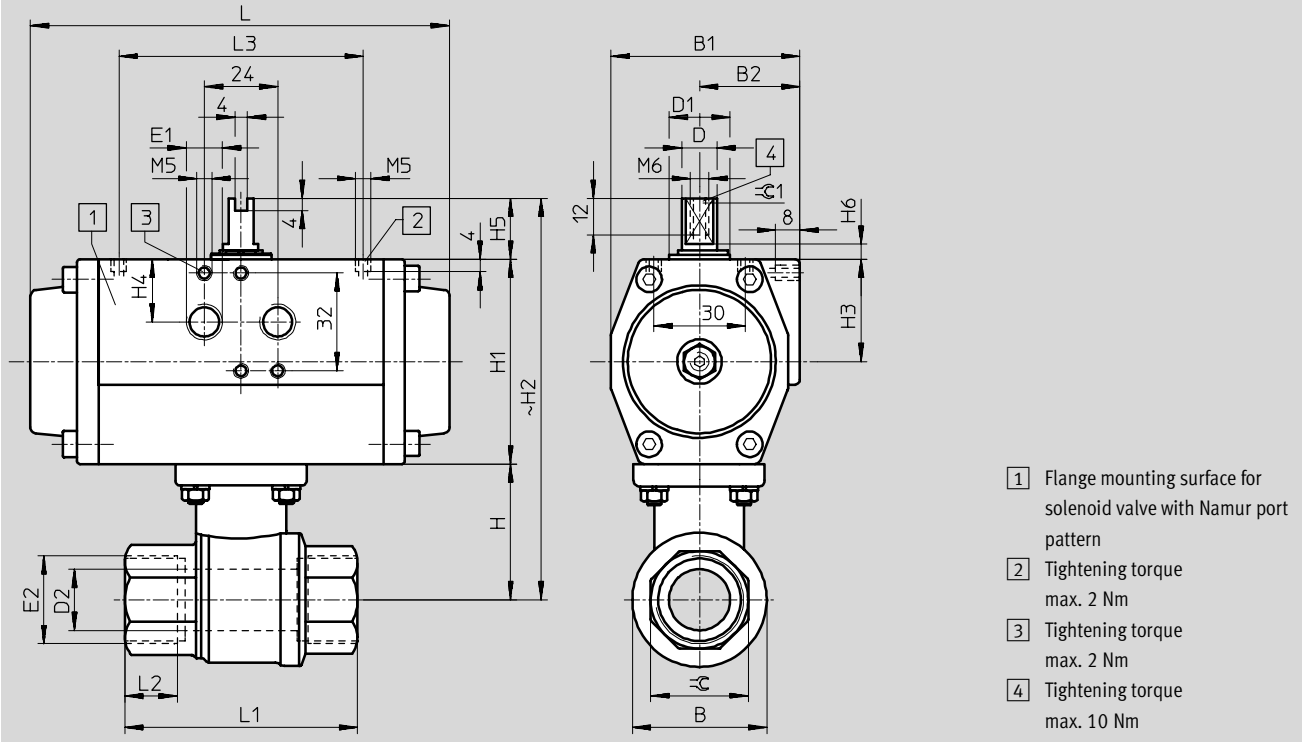

Connecting thread E2 ¹⁾	B	B1	B2	D ∅	D1 ∅	D2 ∅	E1	H	H1	H2
G1/4	25.5	66	37	12	20	8	1/8	33	67	120
G3/8	25.5	66	37	12	20	10	1/8	34	67	121
G1/2	34	66	37	12	20	15	1/8	35.5	67	122.5
G3/4	44	66	37	12	20	20	1/8	45.5	67	132.5
G1	53	80.5	44	12	20	25	1/4	49.5	83	152.5
G1 1/4	66	80.5	44	12	20	32	1/4	63	83	166
G1 1/2	79	91	48	18	27	40	1/4	69	100	189
G2	95	91	48	18	27	50	1/4	85	100	205

Connecting thread E2 ¹⁾	H3	H4	H5	H6	L	L1	L2	L3	≈C	≈C1
G1/4	41	22	20	5	138	50	10	80	19	8
G3/8	41	22	20	5	138	60	11.4	80	22	8
G1/2	41	22	20	5	138	75	15	80	27	8
G3/4	41	22	20	5	138	80	16.3	80	32	8
G1	42	21	20	4.5	152	90	19.1	80	41	8
G1 1/4	42	21	20	4.5	152	110	21.4	80	50	8
G1 1/2	46	23	20	4.5	202	120	21.4	80	55	14
G2	46	23	20	4.5	202	140	25.7	80	70	14

1) Cylindrical barrel with female thread to DIN ISO 228-1



Ball valve drive units QH-DR

Technical data

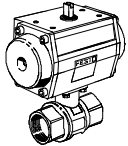

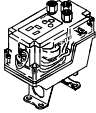

Ordering data – Ball valve drive units			
Design	Connecting thread ¹⁾	Part No.	Type
	G1/4	164 242	QH-DR-1/4-B
	G3/8	164 243	QH-DR-3/8-B
	G1/2	164 244	QH-DR-1/2-B
	G3/4	164 245	QH-DR-3/4-B
	G1	164 246	QH-DR-1-B
	G1 1/4	164 247	QH-DR-1 1/4-B
	G1 1/2	164 248	QH-DR-1 1/2-B
	G2	164 249	QH-DR-2-B

1) Cylindrical barrel with female thread to DIN ISO 228-1

Ordering data – Accessories			
	Description	Part No.	Type
Limit switch attachments			Technical data → 7 / 1.2-60
	pneumatic sensing with S-3-PK-3-B	164 855	QH-DR-E-S3-PK-3-B-B
	electrical sensing with S-3-E-SW	164 854	QH-DR-E-S3-E-SW-B
	inductive sensing with SIE-M12S-...	164 853	QH-DR-E-SIEN-M12-NB-B
Solenoid valves, 5/2-way			Technical data → 7 / 2.1-6
	–	535 987	NVF3-MOH-5/2-K-1/4-EX
	explosion-proof, intrinsically safe	535 988	NVF3-MOH-5/2-K-1/4-IA-EX

Ball valve drive units CRQH-DR, stainless steel

Technical data

-  - Connecting thread
G $\frac{1}{4}$... G2
-  - Flow rate Kv
5.1 ... 191 m³/min

- Corrosion and acid resistant design
- Combination of a ball valve and pneumatic rotary drive
- Connecting thread to DIN ISO 228-1
- Solenoid valves with the Namur port pattern can be connected directly
- Limit switch attachments can be screwed directly onto the drive unit



General technical data								
Connecting thread	G $\frac{1}{4}$	G $\frac{3}{8}$	G $\frac{1}{2}$	G $\frac{3}{4}$	G1	G1 $\frac{1}{4}$	G1 $\frac{1}{2}$	G2
Valve function	2/2 way							
Design	Ball valve							
Sealing principle	Soft							
Actuation type	Pneumatic							
Direction of flow	Reversible							
Type of mounting	In-line installation							
Mounting position	Any							
Nominal size [mm]	9	12	16	20	25	32	40	50
Flow rate Kv [m ³ /min]	5.1	6.8	16	26	47	70	145	191
Product weight [g]	1,500	1,500	1,500	1,700	2,650	3,350	5,450	7,150

Operating and environmental conditions								
Connecting thread	G $\frac{1}{4}$	G $\frac{3}{8}$	G $\frac{1}{2}$	G $\frac{3}{4}$	G1	G1 $\frac{1}{4}$	G1 $\frac{1}{2}$	G2
Operating medium	Compressed air, water, neutral gasses, neutral fluids Vacuum							
Pilot medium	Filtered compressed air, lubricated or unlubricated							
Nominal operating pressure [bar]	63	63	63	50	50	40	40	32
Temperature of medium [°C]	-40 ... +200 (for water 4 ... 160)							
Ambient temperature [°C]	-20 ... +85							
Corrosion resistance class CRC ¹⁾	3							

1) Corrosion resistance class 3 according to Festo standard 940 070
Components requiring higher corrosion resistance. External visible parts in direct contact with industrial atmospheres or media such as solvents and cleaning agents, with a predominantly functional requirement for the surface.

Materials		
Ball valve		
Housing	Corrosion resistant cast steel	
Ball	Corrosion resistant cast steel	
Seals	Housing	Polytetrafluoroethylene, fibreglass reinforced
	Shaft	Polytetrafluoroethylene, fibreglass reinforced
Rotary drive		
Housing	Hard anodised aluminium	
Shaft	Nickel plated steel	

Ball valve drive units CRQH-DR, stainless steel

Technical data



Minimum pilot pressure as a function of operating pressure¹⁾

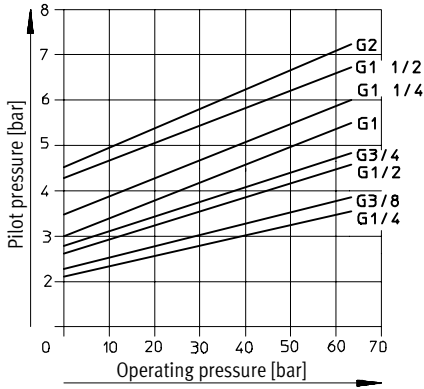

Response times as a function of operating pressure²⁾

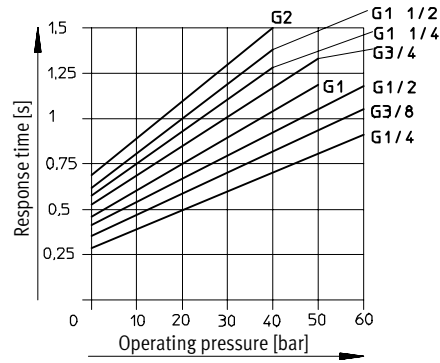

- 1) For lubricating media. Values may be as much as 30% higher for non-lubricating media.
- 2) Guide values at 5 bar pilot pressure

Permissible operating pressure as a function of the temperature of the medium

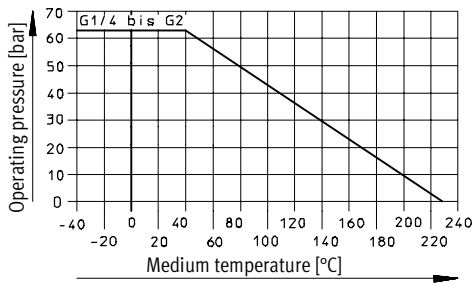

Standard directional control valves
Ball valves

2.2



Ball valve drive units CRQH-DR, stainless steel

Technical data

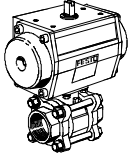

Ordering data – Ball valve drive units			
Design	Connecting thread ¹⁾	Part No.	Type
	G1/4	154 074	CRQH-DR-1/4-B
	G3/8	154 075	CRQH-DR-3/8-B
	G1/2	154 076	CRQH-DR-1/2-B
	G3/4	154 077	CRQH-DR-3/4-B
	G1	154 078	CRQH-DR-1-B
	G1 1/4	154 079	CRQH-DR-1 1/4-B
	G1 1/2	154 080	CRQH-DR-1 1/2-B
	G2	154 081	CRQH-DR-2-B

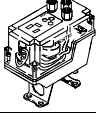
1) Cylindrical barrel with female thread to DIN ISO 228-1

Ordering data – Accessories			
	Description	Part No.	Type
Limit switch attachments			Technical data → 7 / 1.2-60
	pneumatic sensing with S-3-PK-3-B	164 855	QH-DR-E-S3-PK-3-B-B
	electrical sensing with S-3-E-SW	164 854	QH-DR-E-S3-E-SW-B
	inductive sensing with SIE-M12S-...	164 853	QH-DR-E-SIEN-M12-NB-B
Solenoid valves, 5/2-way			Technical data → 7 / 2.1-6
	–	535 987	NVF3-MOH-5/2-K-1/4-EX
	explosion-proof, intrinsically safe	535 988	NVF3-MOH-5/2-K-1/4-IA-EX