

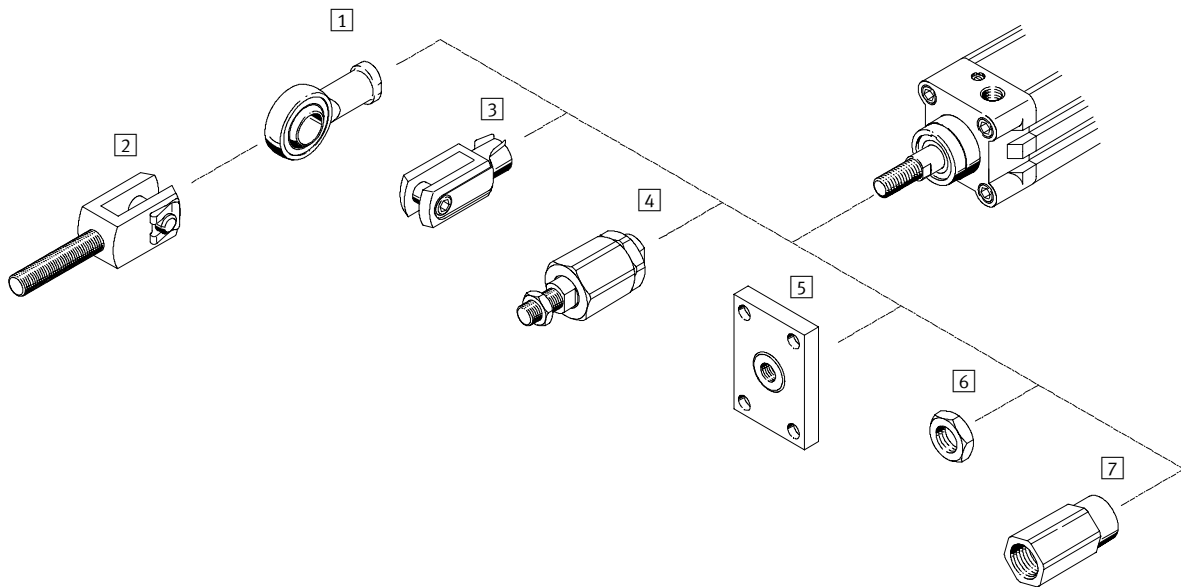

- Co-ordinated with Festo's cylinder range
- Versatile combinations
- Sturdy and functional
- Stainless steel variants

# Piston rod attachments

Peripherals overview



Mounting attachments and accessories		Brief description
1	Rod eye SGS	Rod eyes are maintenance-free due to the combination of steel and PTFE-bronze material in the swivel bearing. Corresponds to DIN ISO 12 240-4 dimensional series K and CETOP RP 103 P.
	Rod eye CRSGS	Corrosion and acid-resistant design. Corresponds to DIN ISO 12 240-4 dimensional series K and CETOP RP 103 P.
2	Rod clevis SGA	Rod clevises are used in combination with the rod eye SGS for spherical connection of cylinders.
	Rod clevis CRSG	This rod clevis is fitted to the threaded end of the piston rod and permits a swivelling movement of the cylinder in one plane. Corresponds to DIN ISO 8140 or DIN 71 752
3	Rod clevis SG	Corrosion and acid-resistant design. Corresponds to DIN ISO 8140 or DIN 71 752
	Rod clevis CRSG	Corrosion and acid-resistant design. Corresponds to DIN ISO 8140 or DIN 71 752
4	Self-aligning rod coupler FK	Rod couplers link the piston rod end of all cylinder types to the machine parts to be moved. This compensates for radial and angular deviations (misalignment).
	Coupling piece KSG	Coupling pieces link the piston rod end of all cylinder types to the machine parts to be moved. They compensate radial misalignments up to $\pm 1$ mm.
5	Coupling piece KSZ	For cylinders with non-rotating piston rods. With this coupling piece, a cylinder can be connected with positional stability to the component being moved in order to compensate for radial deviation.
	Hex nut MSK	Based on and/or corresponds to DIN EN ISO 8675.
7	Adapter AD	Specially for through, hollow piston rods, e.g. for connecting vacuum generators.

# Piston rod attachments

Product range overview



Piston rod attachments						
Piston rod thread		Rod eye		Rod clevis		
Male	Female	SGS-...	CRSGS-...	SGA-... <sup>1)</sup>	SG-...	CRSG-...
M4		■	-	-	■	-
M6		■	■	-	■	■
M8		■	■	-	■	■
M10		■	-	-	■	-
M10x1.25		■	■	■	■	■
M12		■	-	■	■	-
M12x1.25		■	■	■	■	■
M16		■	-	■	■	-
M16x1.5		■	■	■	■	■
M20x1.5		■	■	■	■	■
M27x2		■	■	■	■	■
M36x2		■	-	-	■	-
M42x2		■	-	-	■	-
M48x2		■	-	-	■	-
<b>Technical data → Page</b>		1 / 10.3-4	1 / 10.3-5	1 / 10.3-6	1 / 10.3-7	1 / 10.3-8

1) Only to be attached to the piston rod in conjunction with the rod eye SGS.

Piston rod attachments						
Piston rod thread		Self-aligning rod coupler	Coupling piece		Hex nut	Adapter
Male	Female	FK-...	KSG-...	KSZ-...	MSK-...	AD-...
M4		■	-	-	-	-
M6		■	-	■	-	■
M8		■	-	■	-	■
M10		■	-	-	-	-
M10x1.25		■	■	■	■	■
M12		■	-	-	-	-
M12x1.25		■	■	■	■	■
M16		■	-	-	-	-
M16x1.5		■	■	■	■	-
M20x1.5		■	■	■	-	-
M27x2		■	■	-	-	-
M36x2		■	-	-	-	-
M42x2		-	-	-	-	-
M48x2		-	-	-	-	-
	M4	■	-	-	-	-
	M5	■	-	-	-	-
	M6	■	-	-	-	-
	M8	■	-	-	-	-
	M10	■	-	-	-	-
	M12	■	-	-	-	-
<b>Technical data → Page</b>		1 / 10.3-9	1 / 10.3-10	1 / 10.3-11	1 / 10.3-12	1 / 10.3-13

# Rod eyes SGS

Data sheet



## Rod eye SGS

Scope of delivery:

1 rod eye, 1 hex nut to DIN 439

Material:

Galvanised steel

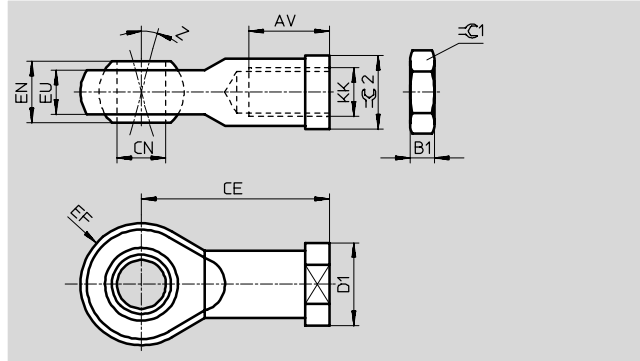

Dimensions and ordering data								
KK	AV	B1	CE	CN ∅ H7	D1 ∅	EF ±0.5	EN	EU
M4	10 -2	2.2	27	5	11	9	8	6
M6	12 -2	3.2	30	6	13	10	9	6.8
M8	16 -2	4	36	8	16	12	12	9
M10	20 -2	5	43	10	19	14	14	10.5
M10x1.25								
M12	22 -2	6	50	12	22	16	16	12
M12x1.25								
M16	28 -2	8	64	16	27	21	21	15
M16x1.5								
M20x1.5	33 -2	10	77	20	34	25	25	18
M27x2	51 -2	13.5	110	30	50	35	37	25
M36x2	56 +2	18	125	35	58	40	43	28
M42x2	60 +2	21	142	40	65	45	49	33
M48x2	65 +2	24	160	50	75	58	60	45

KK	Z [°]	∠1	∠2	DIN ISO 12 240-4 dimensional series K	CETOP RP 103 P	CRC <sup>1)</sup>	Weight [g]	Part No.	Type
M4	13	7	9	-	■	2	17	9 253	SGS-M4
M6	13	10	11	■	■	2	25	9 254	SGS-M6
M8	13	13	14	■	■	2	45	9 255	SGS-M8
M10	13	17	17	■	-	2	70	9 256	SGS-M10
M10x1.25				-	■	2	70	9 261	SGS-M10x1,25
M12	13	19	19	■	-	2	105	9 257	SGS-M12
M12x1.25				-	■	2	105	9 262	SGS-M12x1,25
M16	15	24	22	■	-	2	210	9 258	SGS-M16
M16x1.5				-	■	2	210	9 263	SGS-M16x1,5
M20x1.5	15	30	30	■	■	2	380	9 264	SGS-M20x1,5
M27x2	15	41	41	-	■	2	1,300	10 774	SGS-M27x2
M36x2	15	55	50	■	■	2	1,825	10 775	SGS-M36x2
M42x2	15	65	55	■	■	2	2,780	10 776	SGS-M42x2
M48x2	12	75	65	■	■	2	5,215	10 777	SGS-M48x2

1) Corrosion resistance class 2 according to Festo standard 940 070

Components requiring moderate corrosion resistance. Externally visible parts with primarily decorative surface requirements which are in direct contact with a surrounding industrial atmosphere or media such as cooling or lubricating agents.

Core Range

# Rod eyes CRSGS, stainless steel

Data sheet



## Rod eye CRSGS

Scope of delivery:

1 rod eye, 1 hex nut to DIN 439

Material:

High-alloy steel

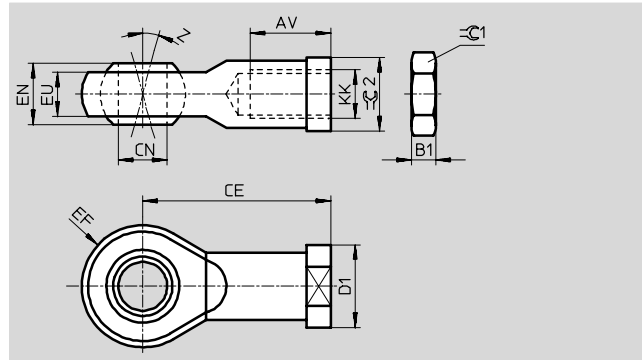

Dimensions and ordering data								
KK	AV	B1	CE	CN Ø	D1 Ø	EF ±0.5	EN	EU
M6	12	3.2	30	6	13	10	9	6.8
M8	16	4	36	8	16	12	12	9
M10x1.25	20	5	43	10	19	14	14	10.5
M12x1.25	22	6	50	12	22	16	16	12
M16x1.5	28	8	64	16	27	21	21	15
M20x1.5	33	10	77	20	34	25	25	18
M27x2	51	13.5	110	30	50	35	37	25

KK	Z [°]	≈C1	≈C2	DIN ISO 12 240-4 dimensional series K	CETOP RP 103 P	CRC <sup>1)</sup>	Weight [g]	Part No.	Type
M6	13	10	11	■	■	4	25	195 580	CRSGS-M6
M8	13	13	14	■	■	4	45	195 581	CRSGS-M8
M10x1.25	13	17	17	–	■	4	70	195 582	CRSGS-M10x1,25
M12x1.25	13	19	19	–	■	4	105	195 583	CRSGS-M12x1,25
M16x1.5	15	24	22	–	■	4	210	195 584	CRSGS-M16x1,5
M20x1.5	15	30	30	■	■	4	380	195 585	CRSGS-M20x1,5
M27x2	15	41	41	–	■	4	1,300	195 586	CRSGS-M27x2

1) Corrosion resistance class 4 according to Festo standard 940 070

Components requiring higher corrosion resistance. Parts used with aggressive media, e.g. food or chemical industry. These applications should be supported with special tests with the media if required.

# Rod clevises SGA

Data sheet



## Rod clevis SGA

Scope of delivery:  
1 rod clevis, 1 pivot pin  
and 1 retaining clip

Material:  
Galvanised steel  
Free of copper, PTFE and silicone

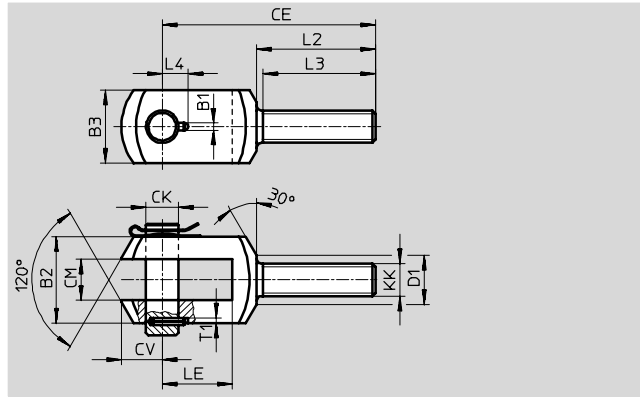

The rod clevis SGA [1] is used in combination with the rod eye SGS [2] (→ 1 / 10.3-4) for spherical mounting of cylinders.

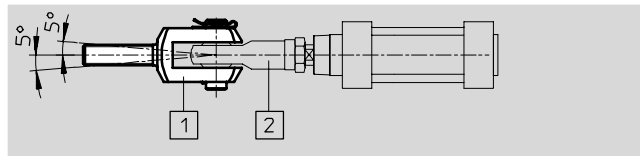

Dimensions and ordering data								
KK	B1	B2	B3	CE	CK ∅ F7/h9	CM B12	CV	D1 ∅
M10x1.25	3.3	28	20	78	10	14	12	18
M12	4.3	30	25	92	12	16	16	19
M12x1.25								
M16	4.3	40	35	108	16	21	21	24
M16x1.5								
M20x1.5	4.3	50	40	131	20	25	25	30
M27x2	6.3	67	60	168	30	37	32	38
M36x2	6.3	78	70	211	35	43	39	48

KK	L2	L3	L4	LE	T1	CRC <sup>1)</sup>	Weight [g]	Part No.	Type
M10x1.25	53	50	11	20	3	2	135	32 954	SGA-M10x1,25
M12	58	55	12	26	3	2	210	6 523	SGA-M12
M12x1.25								10 767	SGA-M12x1,25
M16	65	62	14	31	3	2	500	6 524	SGA-M16
M16x1.5								10 768	SGA-M16x1,5
M20x1.5	73	69	16	43	3	2	1,090	10 769	SGA-M20x1,5
M27x2	98	92	24	54	5	2	2,120	10 770	SGA-M27x2
M36x2	121	115	26.5	72	5	2	3,825	10 771	SGA-M36x2

1) Corrosion resistance class 2 according to Festo standard 940 070  
Components requiring moderate corrosion resistance. Externally visible parts with primarily decorative surface requirements which are in direct contact with a surrounding industrial atmosphere or media such as cooling or lubricating agents.

# Rod clevises SG

Data sheet



## Rod clevis SG

Scope of delivery:

1 rod clevis, 1 hinged spring pin,  
1 hex nut to DIN 439

Material:

Galvanised steel

M4 ... M27: Free of copper, PTFE and  
silicone

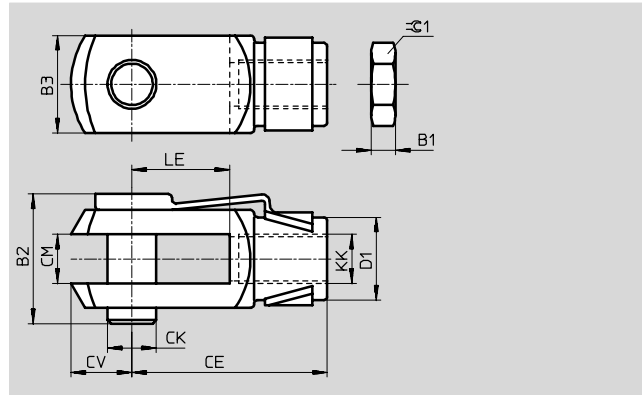

Dimensions and ordering data								
KK	B1	B2	B3	CE	CK ∅ H9	CM	CV	D1 ∅
M4	3.2	11	8	16±0.3	4	4B13	5	8
M6	3.2	16	12	24±0.3	6	6B13	7	10
M8	4	21.5	16	32±0.4	8	8B13	10	14
M10	5	26	20	40±0.4	10	10B13	12	18
M10x1.25								
M12	6	31	24	48±0.4	12	12+0.7/+0.15	14	20
M12x1.25								
M16	8	39	32	64±0.4	16	16+0.7/+0.15	19	26
M16x1.5								
M20x1.5	10	54	40	80±0.4	20	20+0.7/+0.15	25	34
M27x2	13.5	74	55	110±0.4	30	30+0.7/+0.15	38	48
M36x2	18	92	70	144±0.4	35	35+0.7/+0.15	44	60
M42x2	21	111	85	168±0.4	40	40+0.7/+0.15	64	70
M48x2	24	123	90	192±0.4	50	50+0.7/+0.15	73	80

KK	LE ±0.5	≈C1	DIN ISO 8140	DIN 71 752	CRC <sup>1)</sup>	Weight [g]	Part No.	Type
M4	8	7	–	■	2	10	6 532	SG-M4
M6	12	10	■	■	2	20	3 110	SG-M6
M8	16	13	■	■	2	50	3 111	SG-M8
M10	20	16	–	■	2	100	2 674	SG-M10
M10x1.25		17	■	■	2	100	6 144	SG-M10x1,25
M12	24	18	–	■	2	160	2 675	SG-M12
M12x1.25		19	■	■	2	165	6 145	SG-M12x1,25
M16	32	24	–	■	2	355	2 676	SG-M16
M16x1.5			■	■	2	356	6 146	SG-M16x1,5
M20x1.5	40	30	■	–	2	720	6 147	SG-M20x1,5
M27x2	54	41	■	–	2	1,475	14 987	SG-M27x2-B
M36x2	72	55	■	–	2	4,080	9 581	SG-M36x2
M42x2	84	65	■	–	2	6,940	9 582	SG-M42x2
M48x2	96	75	■	–	2	10,010	9 583	SG-M48x2

1) Corrosion resistance class 2 according to Festo standard 940 070

Components requiring moderate corrosion resistance. Externally visible parts with primarily decorative surface requirements which are in direct contact with a surrounding industrial atmosphere or media such as cooling or lubricating agents.

Core Range

# Rod clevises CRSG, stainless steel

Data sheet



## Rod clevis CRSG

Scope of delivery:

1 rod clevis, 1 pivot pin, 1 hex nut to DIN 439

Material:

High-alloy steel

Free of copper, PTFE and silicone

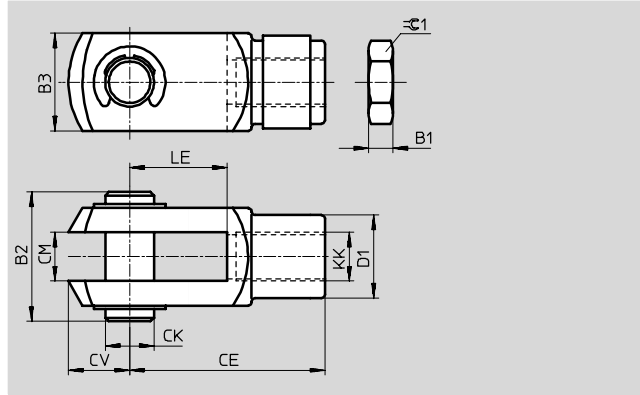

Dimensions and ordering data								
KK	B1	B2	B3	CE	CK ∅ H9	CM	CV	D1 ∅
M6	3.2	19	12	24±0.3	6	6B13	7	10
M8	4	24	16	32±0.4	8	8B13	10	14
M10x1.25	5	27	20	40±0.4	10	10B13	12	18
M12x1.25	6	33	24	48±0.4	12	12+0.7/+0.15	14	20
M16x1.5	8	43	32	64±0.4	16	16+0.7/+0.15	19	26
M20x1.5	10	53	40	80±0.4	20	20+0.7/+0.15	25	34
M27x2	13.5	70	55	110±0.4	30	30+0.7/+0.15	38	48

KK	LE ±0.5	≈C1	DIN ISO 8140	DIN 71 752	CRC <sup>1)</sup>	Weight [g]	Part No.	Type
M6	12	10	■	■	4	25	13 567	CRSG-M6
M8	16	13	■	■	4	55	13 568	CRSG-M8
M10x1.25	20	16	■	■	4	110	13 569	CRSG-M10x1,25
M12x1.25	24	18	■	■	4	180	13 570	CRSG-M12x1,25
M16x1.5	32	24	■	■	4	395	13 571	CRSG-M16x1,5
M20x1.5	36	30	■	-	4	800	13 572	CRSG-M20x1,5
M27x2	54	41	■	-	4	1,900	185 361	CRSG-M27x2

1) Corrosion resistance class 4 according to Festo standard 940 070

Components requiring higher corrosion resistance. Parts used with aggressive media, e.g. food or chemical industry. These applications should be supported with special tests with the media if required.



# Self-aligning rod couplers FK

Data sheet



## Self-aligning rod coupler FK

Scope of delivery:

1 self-aligning rod coupler, 1 hex nut to DIN 439

Material:

Galvanised steel

Free of copper, PTFE and silicone

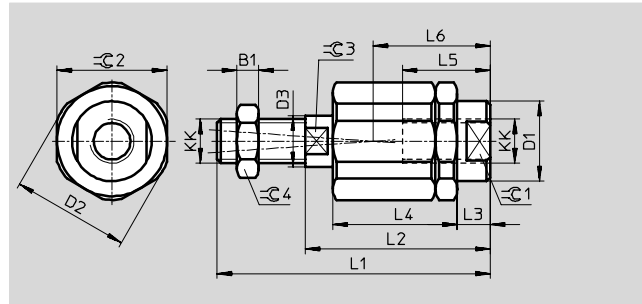

Angular compensation

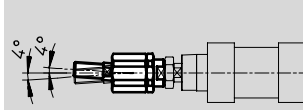

Radial compensation of central axis

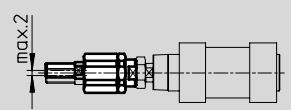

Dimensions and ordering data											
KK	B1	D1 ∅	D2 ∅	D3 ∅	L1	L2	L3	L4	L5	L6	
M4	2.2	–	–	3.8	33	24	4.5	16.5	12.5	16	
M5	2.7	8.5	14.5	5.8	38.5	25	4.4	17.5	11.5	15.7	
M6	3.2	8.5	14.5	5.8	37	25	4.4	17.5	11.5	15.7	
M8	4	12.5	19	7.8	49	34	6	23.5	14	20.5	
M10	5	21.4	32	13.8	67.5	49.5	9	34	23	31	
M10x1.25					69.5						
M12	6	21.4	32	13.8	70.5	49.5	9	34	23	31	
M12x1.25					74.5						50.5
M16	8	33.8	45	22	97	71	10	53	32	44.5	
M16x1.5					103						
M20x1.5	10	33.8	45	22	120	80	19	53	41	53.5	
M27x2	13.5	62	62	28	157	103	12.2	79	42	62.5	
M36x2	18	80	80	38	251	179	22	136	78	110	

KK	∅C1	∅C2	∅C3	∅C4	Radial deviation [mm]	CRC <sup>1)</sup>	Weight [g]	Part No.	Type
M4	11	11	3.2	7	±0.5	2	15	6 528	FK-M4
M5	7	13	5	8	±0.5	2	20	30 984	FK-M5
M6	7	13	5	10	±0.5	2	23	2 061	FK-M6
M8	10	17	7	13	±0.5	2	50	2 062	FK-M8
M10	19	30	12	17	±0.7	2	210	2 063	FK-M10
M10x1.25					±0.7	2	210	6 140	FK-M10x1,25
M12	19	30	12	19	±0.7	2	210	2 064	FK-M12
M12x1.25					±0.7	2	215	6 141	FK-M12x1,25
M16	30	41	19	24	±1	2	670	2 065	FK-M16
M16x1.5					±1	2	650	6 142	FK-M16x1,5
M20x1.5	30	41	19	30	±1	2	720	6 143	FK-M20x1,5
M27x2	55	55	24	41	±1	2	2,100	10 485	FK-M27x2
M36x2	75	75	32	55	±1	2	5,800	10 746	FK-M36x2

1) Corrosion resistance class 2 according to Festo standard 940 070

Components requiring moderate corrosion resistance. Externally visible parts with primarily decorative surface requirements which are in direct contact with a surrounding industrial atmosphere or media such as cooling or lubricating agents.

Core Range

# Coupling pieces KSG

Data sheet



## Coupling piece KSG

Scope of delivery:  
1 flange, 1 threaded coupling

Material:  
Galvanised steel  
Free of copper, PTFE and silicone

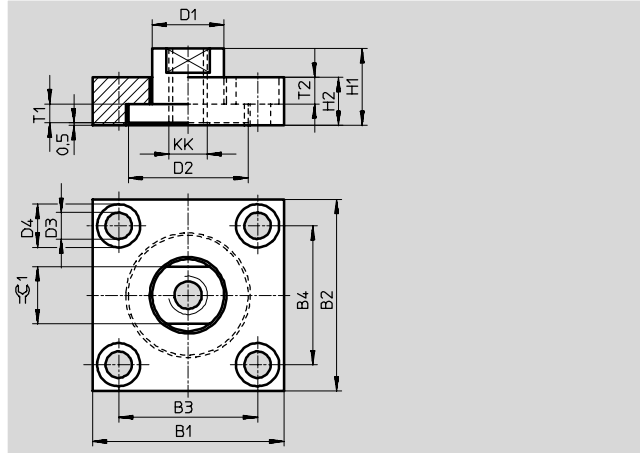

Dimensions and ordering data									
KK	B1	B2	B3	B4	D1 ∅ H11	D2 ∅	D3 ∅ H13	D4 ∅ H13	H1
M10x1.25	60	37	36	23	20	30	6.6	11	24
M12x1.25	60	56	42	38	25	40	9	15	30
M16x1.5	80	80	58	58	30	50	11	18	32
M20x1.5	90	90	65	65	40	60	14	20	35
M27x2	90	90	65	65	40	60	14	20	35

KK	H2	T1	T2	≈C1	CRC <sup>1)</sup>	Weight [g]	Part No.	Type
M10x1.25	15	6.5	6.8	17	2	225	32 963	KSG-M10x1,25
M12x1.25	20	7.5	9	19	2	445	32 964	KSG-M12x1,25
M16x1.5	20	8.5	11	24	2	900	32 965	KSG-M16x1,5
M20x1.5	20	9.5	13	36	2	1,060	32 966	KSG-M20x1,5
M27x2	20	9.5	13	36	2	1,150	32 967	KSG-M27x2

1) Corrosion resistance class 2 according to Festo standard 940 070  
Components requiring moderate corrosion resistance. Externally visible parts with primarily decorative surface requirements which are in direct contact with a surrounding industrial atmosphere or media such as cooling or lubricating agents.

# Coupling pieces KSZ

Data sheet



## Coupling piece KSZ

for non-rotating piston rods

Scope of delivery:

1 flange, 1 threaded coupling

Material:

Galvanised steel

Free of copper, PTFE and silicone

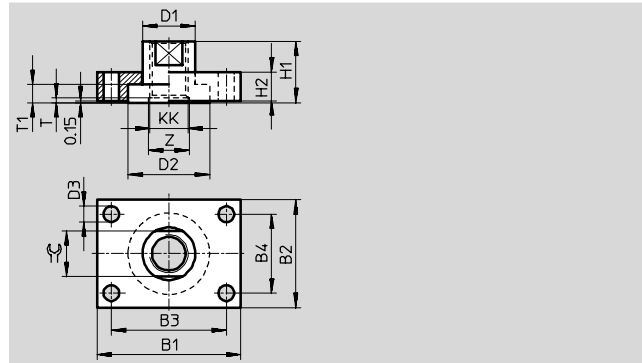

Dimensions and ordering data								
KK	B1	B2	B3	B4	D1 ∅	D2 ∅	D3 ∅	H1
M6	30	25	20	15	12	18	5.5	16
M8	35	30	25	20	14	20	5.5	22
M10x1.25	40	35	30	25	17	26	5.5	20
M12x1.25	50	40	40	30	17	26	5.5	22
M16x1.5	60	45	48	33	22	34	6.6	25
M20x1.5	72	50	57	35	30	44	9	32

KK	H2	T	T1	Z ∅	⌀	CRC <sup>1)</sup>	Weight [g]	Part No.	Type
M6	8	2	3.95	8	10	2	44	<b>36 123</b>	<b>KSZ-M6</b>
M8	8	-	3.95	-	13	2	70	<b>36 124</b>	<b>KSZ-M8</b>
M10x1.25	10	-	5.95	-	15	2	107	<b>36 125</b>	<b>KSZ-M10x1,25</b>
M12x1.25	12	-	5.95	-	15	2	180	<b>36 126</b>	<b>KSZ-M12x1,25</b>
M16x1.5	12	-	6.95	-	19	2	240	<b>36 127</b>	<b>KSZ-M16x1,5</b>
M20x1.5	15	-	8.95	-	27	2	408	<b>36 128</b>	<b>KSZ-M20x1,5</b>

1) Corrosion resistance class 2 according to Festo standard 940 070

Components requiring moderate corrosion resistance. Externally visible parts with primarily decorative surface requirements which are in direct contact with a surrounding industrial atmosphere or media such as cooling or lubricating agents.

Note The torque on the coupling must not exceed the permissible torque on the cylinder.

# Hex nuts MSK

Data sheet



## Hex nut MSK

Material:  
Galvanised steel

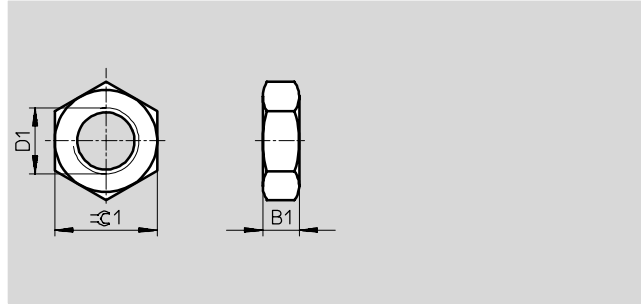

Dimensions and ordering data									
D1	B1	$\approx C1$	Conforms to DIN EN ISO 8675	Based on DIN EN ISO 8675	CRC <sup>1)</sup>	Weight [g]	Part No.	Type	PU <sup>2)</sup>
M10x1.25	5	17	-	■	2	7	189 005	MSK-M10x1,25	10
M12x1.25	6	19	-	■	2	9	189 006	MSK-M12x1,25	10
M16x1.5	8	24	■	-	2	18	189 007	MSK-M16x1,5	10

- 1) Corrosion resistance class 2 according to Festo standard 940 070  
Components requiring moderate corrosion resistance. Externally visible parts with primarily decorative surface requirements which are in direct contact with a surrounding industrial atmosphere or media such as cooling or lubricating agents.
- 2) Packaging unit quantity

# Adapter AD

Data sheet



## Adapter AD

Material:  
Anodised aluminium

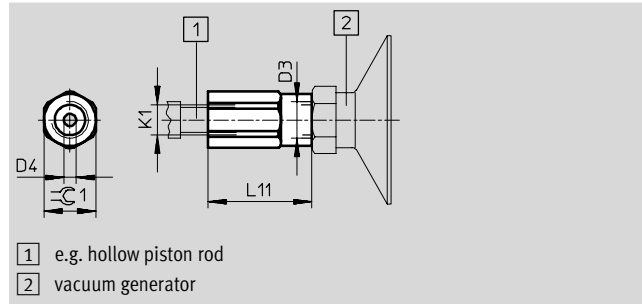

Dimensions and ordering data						
K1	D3	D4 Ø	L11	≅C1	Weight [g]	Part No. Type
M6	M5	2.3	27	10	6	157 328 AD-M6-M5
M6	G $\frac{1}{8}$	2.3	27	13	9	157 329 AD-M6- $\frac{1}{8}$
M6	G $\frac{1}{4}$	2.3	30	17	17	157 330 AD-M6- $\frac{1}{4}$
M8	G $\frac{1}{8}$	3.2	29	13	8	157 331 AD-M8- $\frac{1}{8}$
M8	G $\frac{1}{4}$	3.2	32	17	16	157 332 AD-M8- $\frac{1}{4}$
M10x1.25	G $\frac{1}{8}$	4	31	13	10	157 333 AD-M10x1,25- $\frac{1}{8}$
M10x1.25	G $\frac{1}{4}$	4	34	17	16	157 334 AD-M10x1,25- $\frac{1}{4}$
M12x1.25	G $\frac{1}{4}$	6	34	17	28	160 256 AD-M12x1,25- $\frac{1}{4}$
M12x1.25	G $\frac{3}{8}$	6	37	22	14	160 257 AD-M12x1,25- $\frac{3}{8}$