

Stepper motors MTR-ST

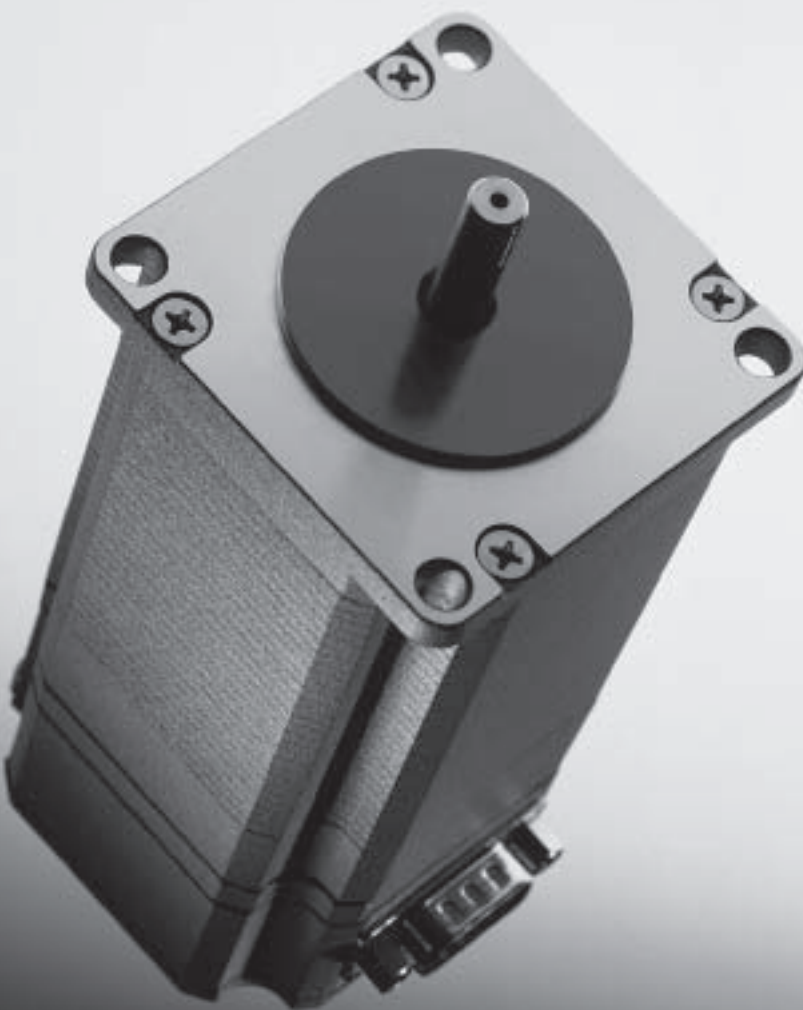

- Low-cost drive solutions
- Simple commissioning
- Co-ordinated motor controller combinations

Stepper motors MTR-ST

Key features

At a glance

Motor MTR-ST

→ 5 / 2.2-6

- System product for positioning applications
- Without/with brake
- Without/with gear unit
- Controlled operation
- High torque at low angle velocity or during single steps
- Step-accurate positioning through specified number of control pulses
- High holding torque and resolution



Motor flange MTR-FL

→ 5 / 2.2-11

- The right motor flange for every motor axis combination



Motor cable KMTR-ST/KMTRE-ST

→ 5 / 2.2-12

- Screened cable
- Can be used at -40 ... +125 °C
- Suitable for chain link trunking
- Protection class IP67



Motor controller SEC-ST

→ 5 / 2.2-13

- System product for positioning applications
- Compact unit, ready for installation
- Adjustable power range for all motors
- Full, half, quarter, fifth, eighth, tenth step mode
- Selectable current reduction
- Pre-assembled electrical connection accessories



Power supply unit SVG-SEC

→ 5 / 2.2-14

- Robust hardware
- High short circuit current
- Input voltage 230 V AC / 115 V AC
- Output voltage 48 V DC



Stepper motors MTR-ST

Selection aid

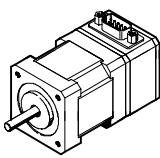
	Motor version	Holding torque M_H in Nm	With integrated controller	With gear unit reduction ratio 4:1	With brake	→ Page
	MTR-ST-42-48S-AA	0.34	-	-	-	5 / 2.2-6
	MTR-ST-42-48S-AB	0.34	-	-	■	
	MTRE-ST-42-48S-AA	0.34	■	-	-	
	MTRE-ST-42-48S-AB	0.34	■	-	■	
	MTR-ST-57-48S-AA	1.27	-	-	-	
	MTR-ST-57-48S-AB	1.27	-	-	■	
	MTR-ST-87-48S-AA	6.47	-	-	-	
	MTR-ST-87-48S-AB	6.47	-	-	■	
	MTR-ST-87-48S-GA	23.29	-	■	-	
	MTR-ST-87-48S-GB	23.29	-	■	■	

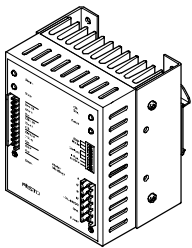
	Motor controller version	Supply voltage	Nominal current	Operating mode	Interface	→ Page
	SEC-ST-48-6-P01	24 ... 48 V DC	1.25 ... 6 A	Full, half, quarter, fifth, eighth, tenth step mode	Pulse/direction	5 / 2.2-13

 Note
MTRE-ST
Stepper motors with integrated
controller.

Stepper motors MTR-ST

Selection aid

Permissible combinations				
Motor	MTR-ST-42-48S-AA ¹⁾ MTR-ST-42-48S-AB ¹⁾	MTRE-ST-42-48S-AA ¹⁾ MTRE-ST-42-48S-AB ¹⁾	MTR-ST-57-48S-AA MTR-ST-57-48S-AB	→ Page
Motor controller				
SEC-ST-48-6-P01	■	■	■	5 / 2.2-13
Cable				
KMTR-ST-...	■	-	■	5 / 2.2-12
KMTRE-ST-...	-	■	-	
Motor flange				
MTR-FL28-ST42	■	■	-	5 / 2.2-11
MTR-FL30-ST42	■	■	-	
MTR-FL44-ST57	-	-	■	
Electro-mechanical drive				
DGE-8-...-ZR	■	■	-	5 / 2.1-2
DGE-12-...-ZR	■	■	-	
DGE-18-...-ZR	-	-	■	
DGE-25-...-ZR	-	-	■	
DGE-18-...-SP	■	■	-	5 / 2.1-114
DGE-25-...-SP	-	-	■	

- 1) The flange MTR-FL30-ST42 must be used in combination with the axis DGE-12-...-ZR.
The flange MTR-FL28-ST42 must be used in combination with the axis DGE-8-...-ZR or DGE-18-...-SP.

Permissible combinations				
Motor	MTR-ST-87-48S-AA ¹⁾ MTR-ST-87-48S-AB ¹⁾	MTR-ST-87-48S-GA MTR-ST-87-48S-GB	→ Page	
Motor controller				
SEC-ST-48-6-P01	■	■	5 / 2.2-13	
Cable				
KMTR-ST-...	■	■	5 / 2.2-12	
KMTRE-ST-...	-	-		
Motor flange				
MTR-FL44-ST87	■	-	5 / 2.2-11	
MTR-FL64-ST87	■	-		
MTR-FL64-PL80	-	■		
Electro-mechanical drive				
DGE-25-...-ZR	■	-	5 / 2.1-2	
DGE-40-...-ZR	-	■		
DGE-40-...-SP	■	-	5 / 2.1-114	
DGE-63-...-SP	-	■		
DGEA-18-...-ZR	■	-	5 / 2.1-92	
DGEA-25-...-ZR	■	-		
DGEA-40-...-ZR	-	■		

- 1) The flange MTR-FL44-ST87 must be used in combination with the axis DGE-25-...-ZR or DGEA-18-...-ZR.
The flange MTR-FL64-ST87 must be used in combination with the axis DGE-40-...-SP or DGEA-25-...-ZR.

Stepper motors MTR-ST

Type code

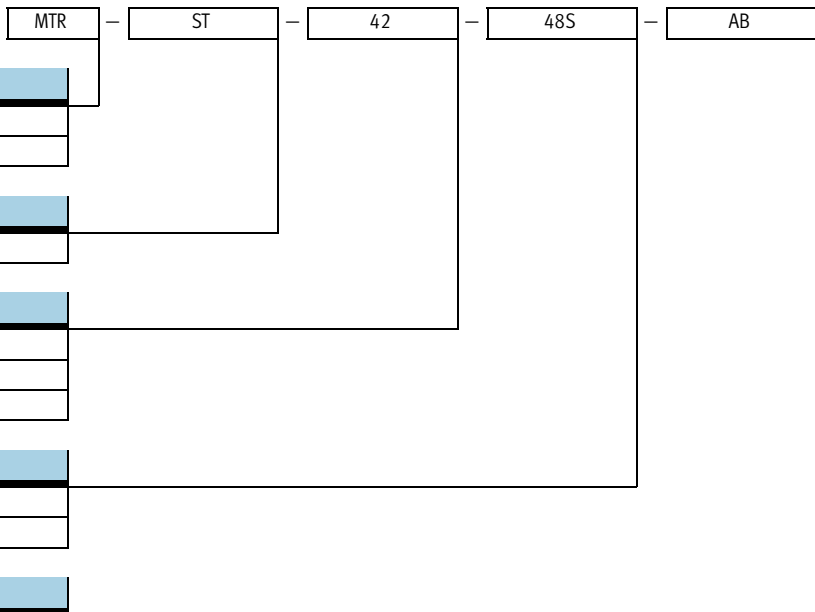

Type

MTR	Motor
MTRE	Motor with integrated controller

Motor type

ST	Stepper motor
----	---------------

Flange dimensions

42	42 mm
57	57 mm
87	87 mm

Nominal voltage/connection type

48	24 ... 48 V DC
S	Plug connection

Additional function

A	No additional function
G	Gear unit
B	Brake

Stepper motors MTR-ST

Technical data



Electrical and mechanical data for MTR-ST-42-48S-...		
	MTR-ST-42-48S-AA	MTR-ST-42-48S-AB
Nominal voltage [V]	48	
Nominal current, motor [A]	1.8	
Holding torque, motor [Nm]	0.34	
Stepper angle (full step) [°]	1.8 ±5%	
Winding resistance [Ω]	1.75 ±10%	
Winding inductance [mH]	3.0	
Drive mass moment of inertia [kg cm ²]	0.068	0.07
Voltage, brake [V]	–	24
Power, brake [W]	–	6
Holding torque, brake [Nm]	–	0.4
Radial shaft load [N]	18	18
Axial shaft load [N]	7	7
Product weight [kg]	0.39	0.49

Electrical and mechanical data for MTR-ST-42-48S-...		
	MTR-ST-42-48S-AA	MTR-ST-42-48S-AB
Nominal voltage [V]	48	
Nominal current, motor [A]	1.2	
Holding torque, motor [Nm]	0.34	
Stepper angle (full step) [°]	1.8 ±5%	
Drive mass moment of inertia [kg cm ²]	0.068	0.07
Voltage, brake [V]	–	24
Power, brake [W]	–	6
Holding torque, brake [Nm]	–	0.4
Radial shaft load [N]	18	18
Axial shaft load [N]	7	7
Product weight [kg]	0.45	0.55

Electrical and mechanical data for MTR-ST-57-48S-...		
	MTR-ST-57-48S-AA	MTR-ST-57-48S-AB
Nominal voltage [V]	48	
Nominal current, motor [A]	3.1	
Holding torque, motor [Nm]	1.27	
Stepper angle (full step) [°]	1.8 ±5%	
Winding resistance [Ω]	1 ±10%	
Winding inductance [mH]	3.8 ±20%	
Drive mass moment of inertia [kg cm ²]	0.48	0.5
Voltage, brake [V]	–	24
Power, brake [W]	–	6
Holding torque, brake [Nm]	–	0.4
Radial shaft load [N]	71	71
Axial shaft load [N]	10	10
Product weight [kg]	1.2	1.4

Stepper motors MTR-ST

Technical data

Electrical and mechanical data for MTR-ST-87-48S-...					
		MTR-ST-87-48S-AA	MTR-ST-87-48S-AB	MTR-ST-87-48S-GA	MTR-ST-87-48S-GB
Nominal voltage	[V]	48			
Nominal current, motor	[A]	4.7			
Holding torque, motor	[Nm]	6.47		23.29	
Stepper angle (full step)	[°]	1.8 ±5%			
Winding resistance	[Ω]	0.9 ±10%			
Winding inductance	[mH]	10.8 ±20%			
Gear reduction ratio	–	–		4:1	4:1
Gear unit efficiency	–	–		0.9	0.9
Torsional backlash	[arcmin]	–		15	15
Torsional resistance	[Nm/arcmin]	–		5.2	5.2
Drive mass moment of inertia	[kg cm ²]	4	4.05	4.52	4.6
Voltage, brake	[V]	–		24	24
Power, brake	[W]	–		9	9
Holding torque, brake	[Nm]	–		1.4	1.4
Radial shaft load	[N]	130	130	950	950
Axial shaft load	[N]	50	50	1 200	1 200
Product weight	[kg]	4.2	5.0	6.4	7.2

Operating and environmental conditions						
		MTR-ST-42-...	MTRE-ST-42-...	MTR-ST-57-...	MTR-ST-87-...-A...	MTR-ST-87-...-G...
Insulation protection class to VDE 60034		B				
Protection class without/with gear unit		IP54		IP54	IP43	
Ambient temperature	[°C]	0 ... +50				
Storage temperature	[°C]	–25 ... +60				
Relative air humidity (non-condensing)	[%]	45 ... 80				

 **Note**
 Specifications are valid for full step operation, 48 V and maximum continuous output.

Technical data for cables				
	Cable composition	Ambient temperature	Suitable for chain link trunking	Protection class, motor plug
KMTR-ST-...	7 x 0.34 mm ² , screened	–40 ... +125 °C	■	IP67
KMTRE-ST-...	7 x 0.34 mm ² , screened	–40 ... +125 °C	■	IP67

Stepper motors MTR-ST

Technical data

Torque M as a function of n (r.p.m.)

MTR-ST-42-48S...

at nominal voltage 24 V

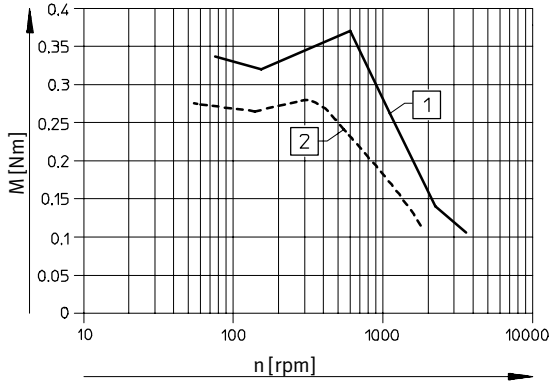

at nominal voltage 48 V

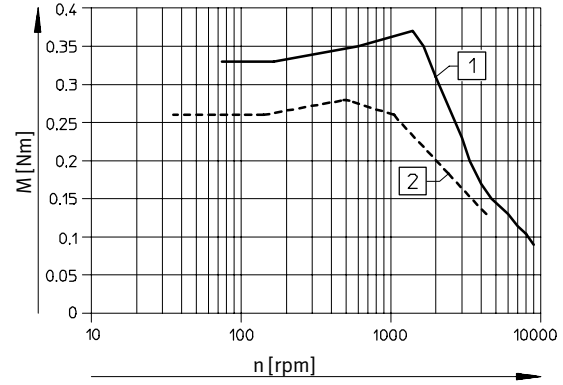

MTR-E-ST-42-48S...

at nominal voltage 24 V

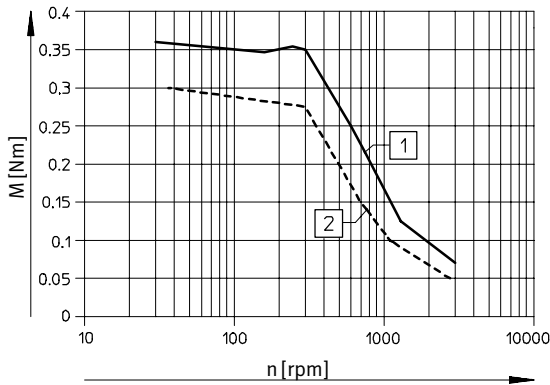

at nominal voltage 48 V

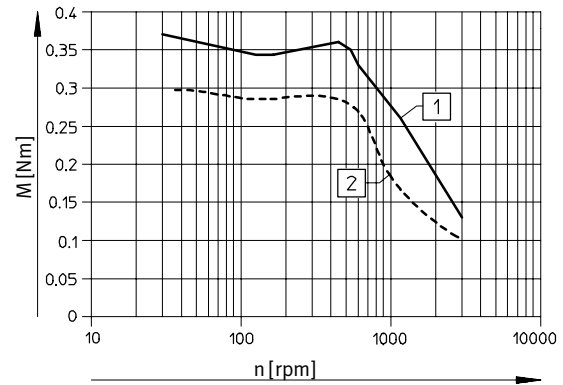

MTR-ST-57-48S...

at nominal voltage 24 V

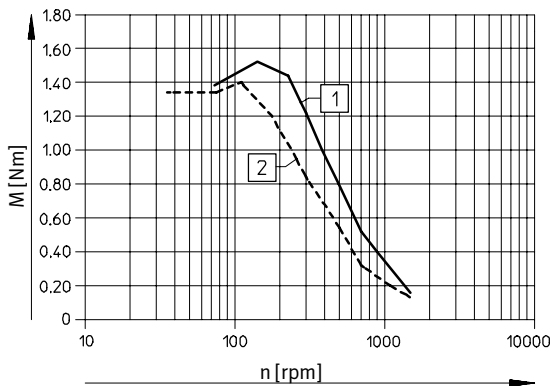

at nominal voltage 48 V

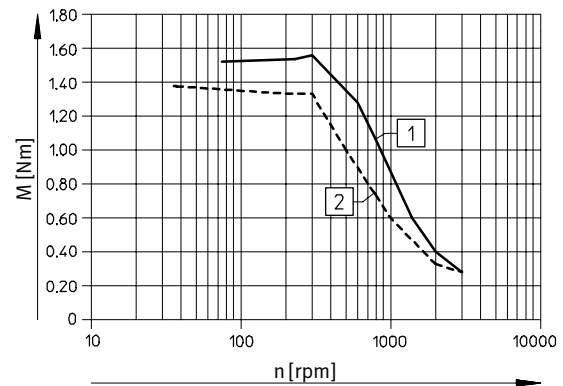

- 1 Full step
- 2 Half step

Stepper motors MTR-ST

Technical data

MTR-ST-87-48S-...
at nominal voltage 24 V at nominal voltage 48 V

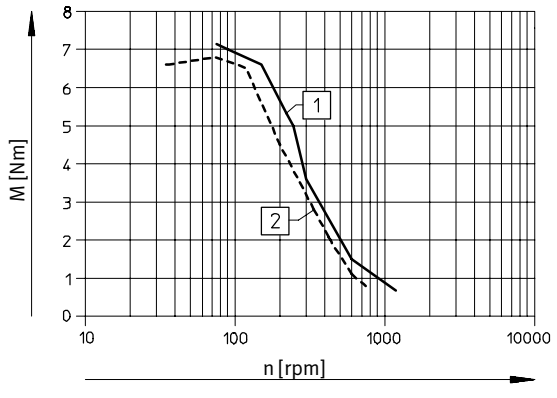
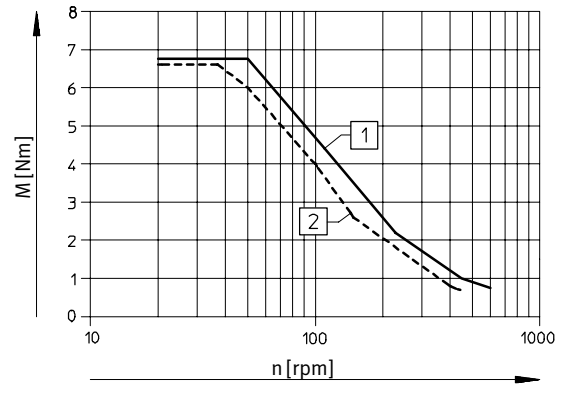

- 1 Full step
- 2 Half step

 Note

Characteristic curves apply to motors without gear unit. The gear unit data must be taken into consideration for motors with gear unit.

Example: Holding torque for motor MTR-ST-87-48S-...	without gear unit: Holding torque = 6.47 Nm (see characteristic curve)	with gear unit: Gear reduction ratio = 4:1 Gear unit efficiency = 0.9 Holding torque = $6.47 \text{ Nm} \times 4 \times 0.9 = 23.29 \text{ Nm}$
--	--	---

Stepper motors MTR-ST

Technical data

Dimensions

Download CAD data → www.festo.com/en/engineering

Motor

MTR-ST-...-A.../MTRE-ST-...-A... (without gear unit)

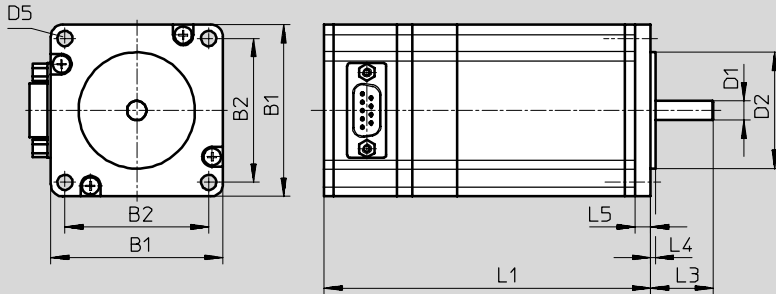

MTR-ST-...-G... (with gear unit)

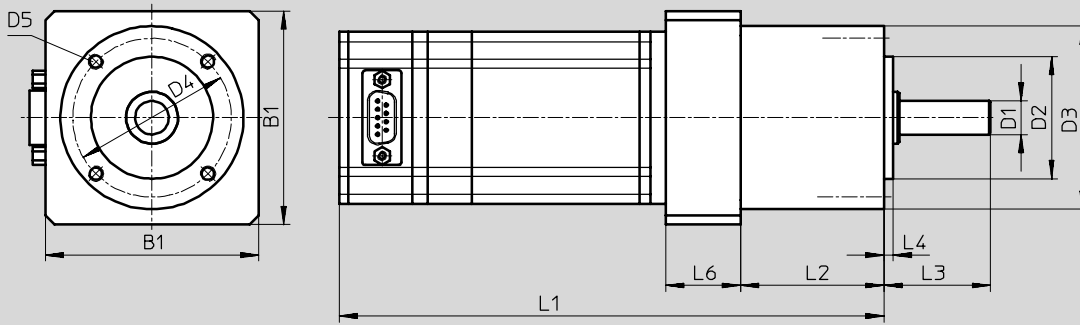

Type	B1	B2	D1 ∅	D2 ∅	D3 ∅	D4 ∅	D5	L1	L2	L3	L4	L5	L6
MTR-ST-42-48S-AA	42	31	5	22	-	-	M3	73	-	24	2	-	-
MTR-ST-42-48S-AB								94					
MTRE-ST-42-48S-AA	42	31	5	22	-	-	M3	111	-	24	2	-	-
MTRE-ST-42-48S-AA								136					
MTR-ST-57-48S-AA	56.4	47.14	6.35	38.1	-	-	∅ 5	107	-	20.6	1.6	5	-
MTR-ST-57-48S-AB								128					
MTR-ST-87-48S-AA	85.8	69.6	11	73.025	-	-	∅ 6.6	156	-	27	2	10	-
MTR-ST-87-48S-AA								176					
MTR-ST-87-48S-GA	90	-	20	60	80	70	M6	252	60.5	40	3	10	35.5
MTR-ST-87-48S-GB								272					

Stepper motors MTR-ST

Technical data

Dimensions

Download CAD data → www.festo.com/en/engineering

Motor flange

MTR-FL28-ST42

MTR-FL30-ST42 / MTR-FL44-ST57 / MTR-FL44-ST87

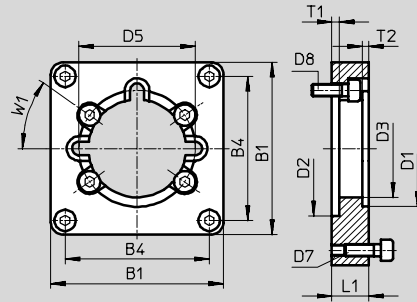
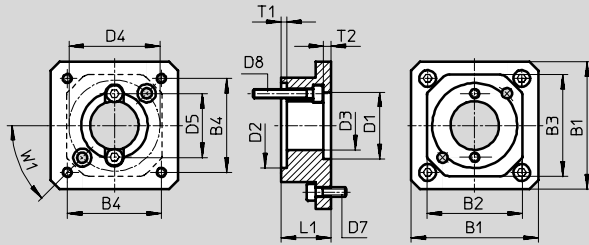

MTR-FL64-ST87

MTR-FL64-PL80

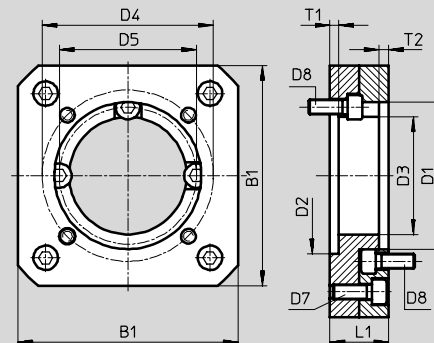
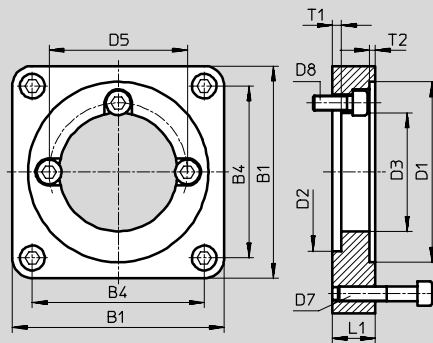

Type	B1	B2	B3	B4	D1 ∅ G7	D2 ∅ H7	D3 ∅	D4 ∅	D5 ∅	D7	D8	L1	T1	T2	W1
MTR-FL28-ST42	42	31.5	33.5	31	22	28	16	30	21	M3	M3	16.5	1.8	2.5	45°
MTR-FL30-ST42	42	-	-	31	22	30	16	-	26.2	M3	M3	18	4.6	2.5	30°
MTR-FL44-ST57	56.4	-	-	47.14	38.125	44	32	-	38	M4	M4	12	2.5	2	35°
MTR-FL44-ST87	85.8	-	-	69.6	73.05	44	32	-	38	M6	M4	15.5	2.5	2.5	35°
MTR-FL64-ST87	85.8	-	-	69.6	73.05	64	48	-	56	M6	M6	17.5	3.8	2.5	-
MTR-FL64-PL80	90	-	-	69.6	60	64	48	70	56	M6	M6	24	3.6	4	-

Stepper motors MTR-ST

Technical data

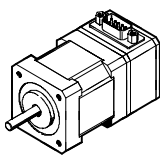
Ordering data for motor MTR...-ST-...			
		Part No.	Type
	MTR-ST-42-48S-...	530 057	MTR-ST-42-48S-AA
		530 058	MTR-ST-42-48S-AB
	MTRE-ST-42-48S-...	530 059	MTRE-ST-42-48S-AA
		530 060	MTRE-ST-42-48S-AB
	MTR-ST-57-48S-...	530 061	MTR-ST-57-48S-AA
		530 062	MTR-ST-57-48S-AB
	MTR-ST-87-48S-...	530 065	MTR-ST-87-48S-AA
		530 066	MTR-ST-87-48S-AB
		530 067	MTR-ST-87-48S-GA
		530 068	MTR-ST-87-48S-GB

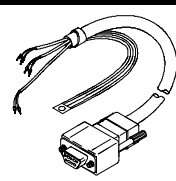
Ordering data for cable KMTR-ST-.../KMTRE-ST-...				
		Part No.	Type	Cable length
	Motor cable KMTR-ST-...	530 071	KMTR-ST-5	5 m
		530 072	KMTR-ST-10	10 m
		530 073	KMTR-ST-X	X length (max. 25 m)
	Motor cable for motor with integrated controller KMTRE-ST-...	530 074	KMTRE-ST42-5	5 m
		530 075	KMTRE-ST42-10	10 m
		530 076	KMTRE-ST42-X	X length (max. 25 m)

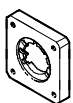
Ordering data for flange MTR-FL-...			
		Part No.	Type
	MTR-FL28-...	530 080	MTR-FL28-ST42
	MTR-FL30-...	530 079	MTR-FL30-ST42
	MTR-FL44-...	530 081	MTR-FL44-ST57
		530 082	MTR-FL-44-ST87
	MTR-FL64-...	533 140	MTR-FL64-ST87
		533 139	MTR-FL64-PL80

Motor controller SEC-ST, for stepper motors

Technical data



Explanation of the functions/interfaces

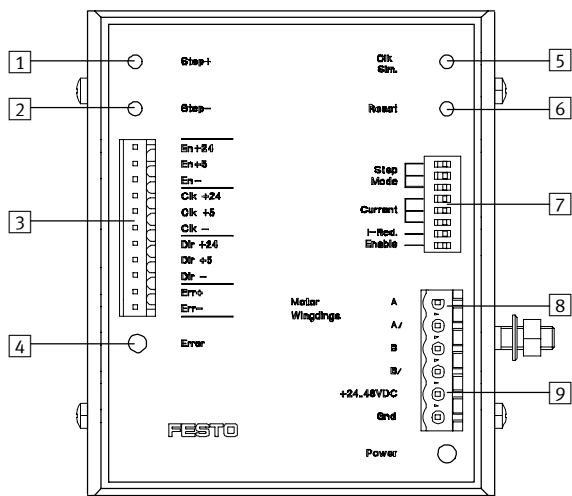

- 1 "Step +" button
- 2 "Step -" button
- 3 Plug X1 for control cable (step, direction, etc.)
- 4 LED, indicates an error
- 5 "CLK, Sim." button
- 6 "Reset" button
- 7 DIP switch for setting the operating mode, current value and current reduction
- 8 Plug X2 for motor connection
- 9 Plug X3 for supply voltage

General electrical data		SEC-ST-48-6-P01
Nominal operating voltage V_{nominal}	[V DC]	24 ... 48
Nominal current (adjustable) I_{nominal}	[A]	1.25 ... 6 via DIP switch
Max. step frequency	[kHz]	40
Current reduction (adjustable)	[%]	0 or 70 via DIP switch
Operating range Logic input	[V DC]	12 ... 30
System mode		Bipolar chopper driver
Operating mode		Full step = 200 steps/revolution Half step = 400 steps/revolution (recommended) Quarter step = 800 steps/revolution Fifth step = 1000 steps/revolution Eighth step = 1600 steps/revolution Tenth step = 2000 steps/revolution
Step adjustment		Via DIP switch

Motor controller SEC-ST, for stepper motors

Technical data and accessories

Operating and environmental conditions		
		SEC-ST-48-6-P01
Ambient temperature	[°C]	0 ... +40
Storage temperature	[°C]	-10 ... +50
Weight	[kg]	0.61
Protection class		IP20
Connection type		Screw terminal
Type of mounting		TS 35 DIN H-rail

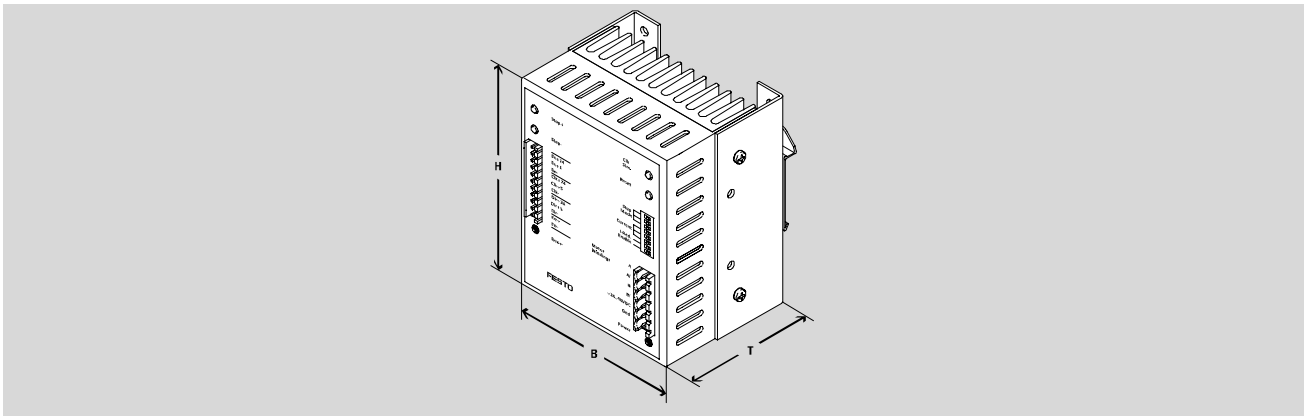

Dimensions and ordering data						
	H	W	D	Part No.	Type	
Motor controller	106	89	70	530 069	SEC-ST-48-6-P01	

Power supply unit SVG-SEC-48-6

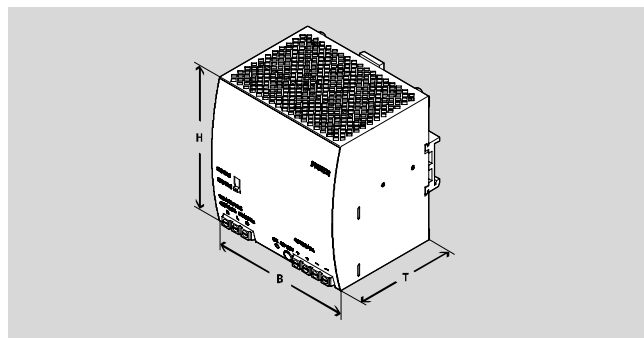

Dimensions and ordering data							
	H	W	D	Output voltage	Nominal current	Part No.	Type
Power supply unit	124	121	102	48 V DC	6 A	530 070	SVG-SEC-48-6

Ordering data for accessories			
		Part No.	Type
	Control cable for connecting to the axis controller SPC200 Cable length 1.5 m	530 077	KSPC-SECST-1,5