

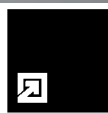

- High precision
- Extremely dynamic
- Modular functionality
- User-friendly installation system

Internationaler
Designpreis
Baden-
Württemberg



Industrie
Forum
Design
Hannover



Product
Design
Award
2000

Linear modules HMPL

Key features

FESTO

At a glance

- Diameter of 12 ... 20 mm
- Stroke lengths of 30 ... 200 mm
- The drive design ensures maximum force and dynamics, especially for vertical operation.
- High precision:
 - Four press-fitted recirculating ball bearing guides and two guide rods ensure high precision and good rigidity
 - Metallic inserts in the limit stops ensure exceptional end-position accuracy results
- Highly dynamic:
 - With integrated shock absorbers, exhaust air flow control and a very rigid housing, the linear module HMPL is capable of cycle times down to <0.5 seconds.
- User-friendly installation system:
 - Centrally arranged and protected cables and tubing.
- Lightweight:
 - The linear module HMPL has a very low dead weight, making it ideal as a front-end axis for the Festo modular system for handling and assembly.
- Modular functionality:
 - By means of versatile and accurate mounting options.

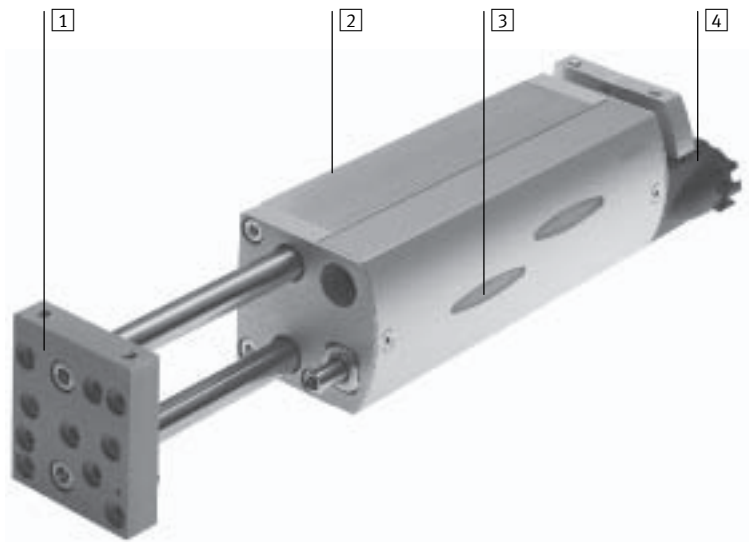

- 1** Front plate
With precision mounting options for attachment components such as drives, grippers, etc.
- 2** Basic profile
The rigid, sealed housing contains both guide and cylinder. High precision and load capacity is achieved by means of the large spacing between the recirculating ball bearing guides.
- 3** Housing cover
For protection against contamination of internal components and with built-in display window.
- 4** Connector cap
Cables and tubing are arranged externally in a centralised, safe and convenient fashion. With mounting option for sensor inscription labels.

Linear modules HMPL

Key features

Wide choice of variants

Internal stop element and position sensing

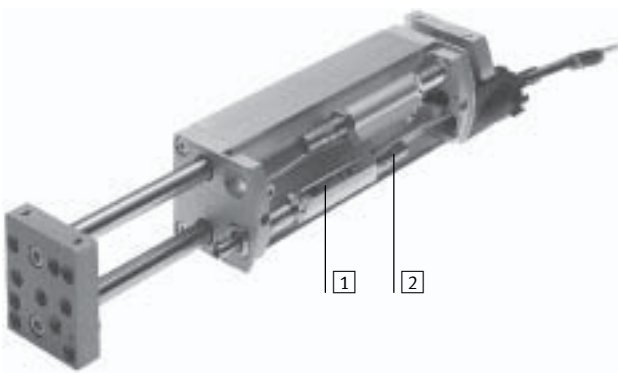

1 Internal stop element
Self-adjusting soft shock absorbers with metallic inserts are used in both end positions. The stop element combines important handling technology functions including position sensing, cushioning stroke adjustment and drive stroke adjustment. Depending upon the size of the stop elements, the end positions can be precision adjusted within a range of up to 20 mm.

2 Position sensing
Sensor slots for proximity sensor SME/SMT-8 are included in the stop elements. The proximity sensor's LED position display can be viewed at the two display windows in the housing cover, even when the linear module is closed.

Clamping unit



A clamping cartridge holds the clamping rod by means of friction (for safety in the event of pressure failure). The clamping rod is attached to the front plate. When the clamping cartridge is pressurised, the guide

rods move freely along with the front plate and the yoke plate. The clamping cartridge can be released by means of an integrated manual override.

Active intermediate position



Travel to any desired position between the end positions of the linear module is made possible with an additionally attached cylinder, and an additional stop element. The intermediate position can be approached from

either the rear or the front end position. Furthermore, continued travel in the original direction is also possible from the intermediate position.

Reinforcing plate



For additional stability, especially for multi-axis operation. The reinforcing plate is attached via the front plate and the yoke plate. Additional functions include a dovetail for

flexible adaptation, and three through-holes through which tubing or cables can be fed, or which can be used for direct air connection.

Linear modules HMPL

System example



System product for handling and assembly technology

Handling units
Linear modules

7.1

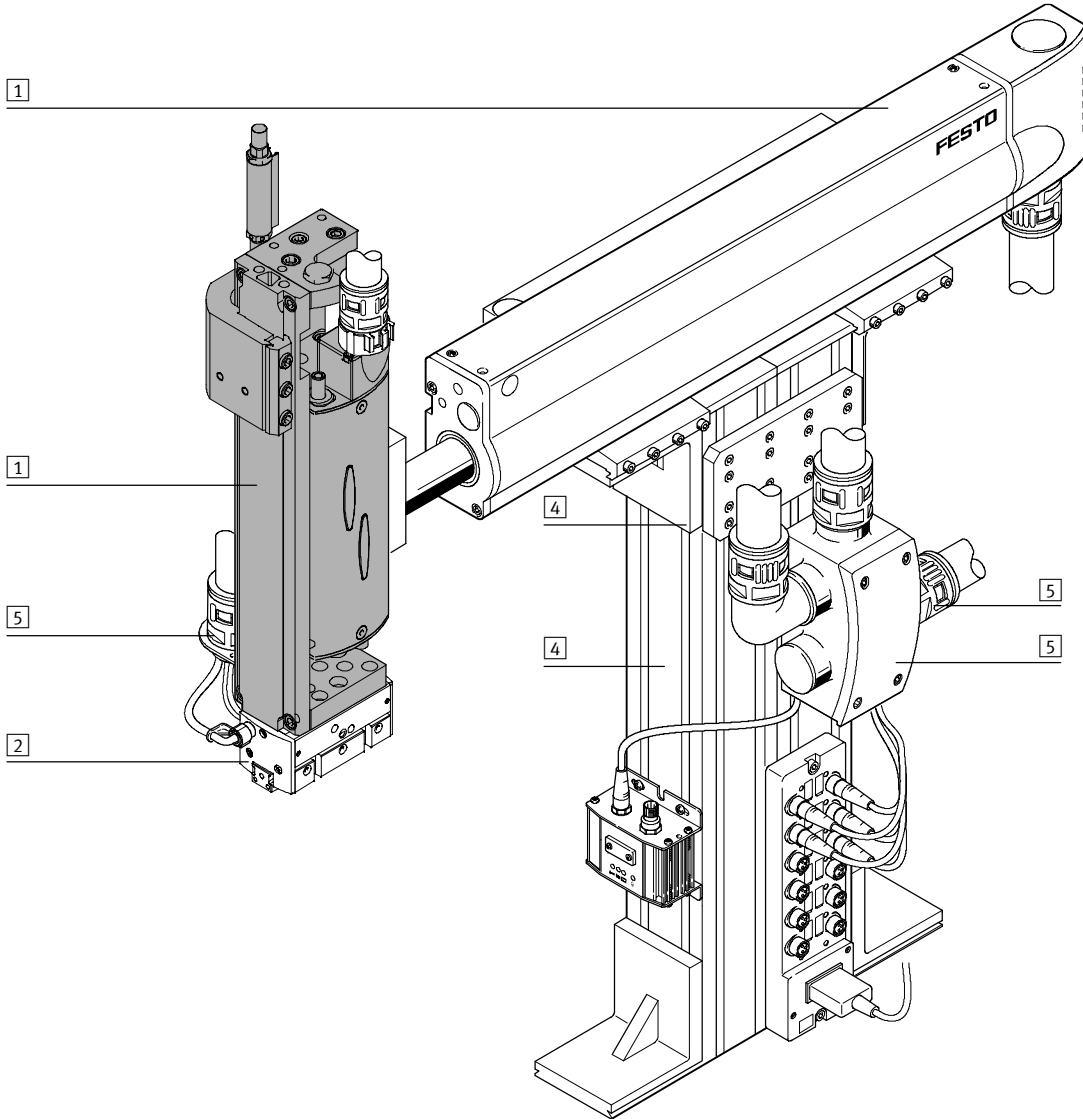

Linear modules HMPL

System example

System elements and accessories		
	Brief description	→ Page
1	Drives	Wide range of combination options within handling and assembly technology Volume 1
2	Grippers	Wide range of combination options within handling and assembly technology Volume 1
3	Basic components	Profiles and profile combinations as well as profile/drive combinations Volume 5
4	Installation components	For achieving a clear-cut, safe layout for electrical cables and tubing Volume 5
-	Adapters	For combining drives with drives and drives with grippers Volume 5
-	Axes	Wide range of combination options within handling and assembly technology Volume 5
-	Motors	Servo and stepper motors, with or without gearing Volume 5

Linear modules HMPL

Peripherals overview

FESTO

Peripherals overview

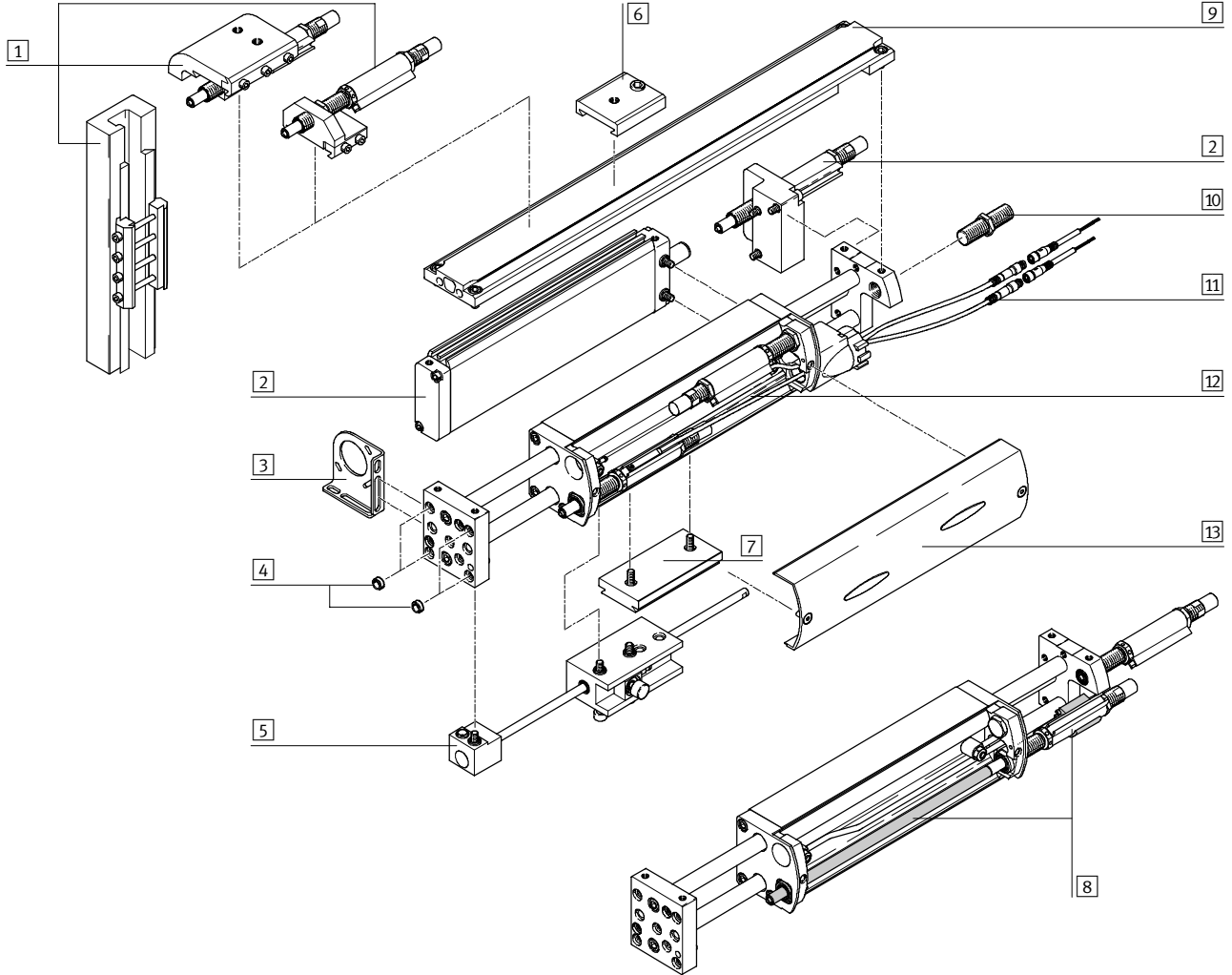

Handling units
Linear modules

7.1

Linear modules HMPL

Peripherals overview



Accessories		
	Brief description	→ Page
1	Passive intermediate position	1 / 7.1-53
2	Active intermediate position M	1 / 7.1-54
3	Mounting bracket H	1 / 7.1-58
4	Centring sleeve Z	1 / 7.1-63
5	Clamping unit KP	1 / 7.1-50
6	Clamping component J	1 / 7.1-58
7	Adapter I	1 / 7.1-58
8	Stop element AI/AE	1 / 7.1-48
9	Reinforcing plate VP	1 / 7.1-52
10	Stop bolt K	1 / 7.1-58
11	Plug socket with cable V	1 / 7.1-64
12	Proximity sensor 2A...	1 / 7.1-63
13	Housing cover	–

Linear modules HMPL

Type codes



		HMPL	-	20	-	200	-	AI	-		-	KP	-	100 M	-	2A1
Type																
HMPL	Linear module															
Piston \varnothing [mm]																
Stroke [mm]																
Stop element																
AI	Integrated															
AE	External															
Reinforcement																
VP	Reinforcing plate															
Clamping unit																
KP	Clamping cartridge															
Active intermediate position																
...M	Active intermediate position															
Proximity sensor																
2A1	With cable, 2.5 m															
2A2	Contactless with cable, 2.5 m, NPN															
2A3	Contactless with cable, 2.5 m, PNP															
2A4	With plug															
2A5	Contactless with plug, NPN															
2A6	Contactless with plug, PNP															

Linear modules HMPL

Type codes

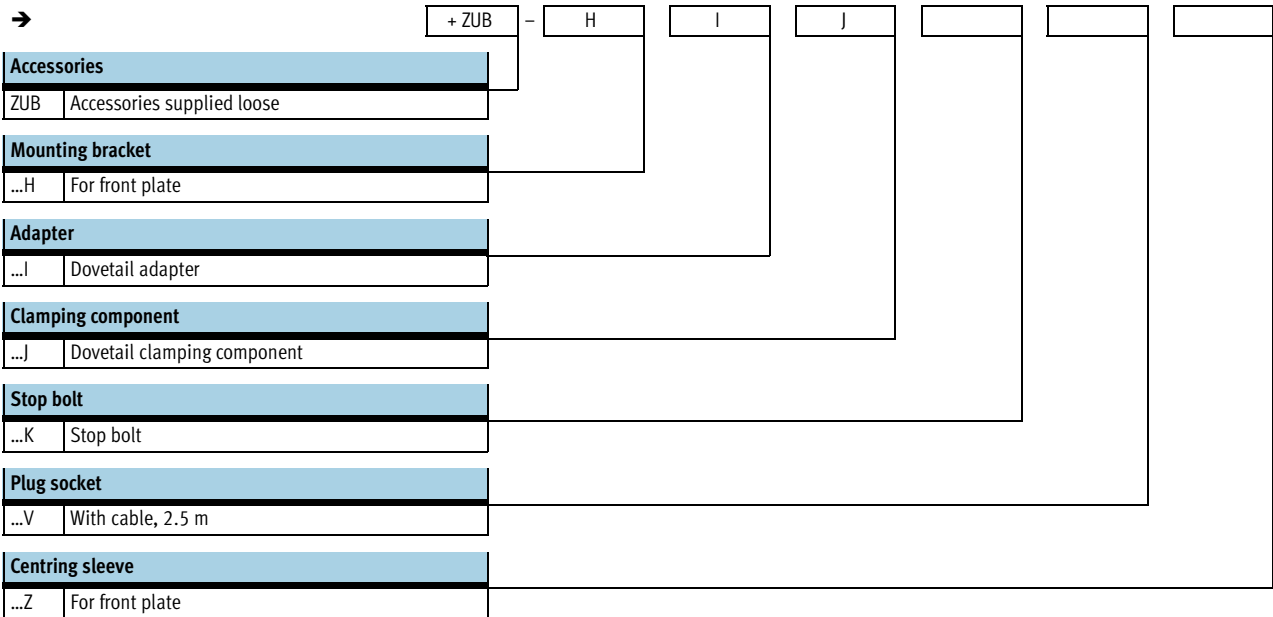



Linear modules HMPL

Technical data

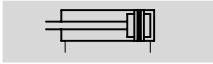

Function



 - Piston \varnothing
 12 ... 20 mm

 - Stroke length
 30 ... 200 mm

 - www.festo.com/en/Spare_parts_service

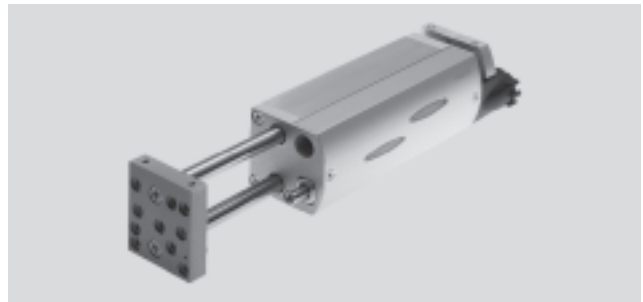

General technical data				
Piston \varnothing		12	16	20
System mode	Yoke			
Mode of operation	Double-acting			
Constructional design	Piston			
	Piston rod			
	Guide rod			
	Front and yoke plate			
Type of connection	Female thread For 2 already integrated one-way flow control valves with 2 tubes with O.D. 4 mm and 2 push-in fittings QSM-4			
Pneumatic connection	M5			
Mounting position	Any			
Stroke	[mm]	30 ... 100	50 ... 160	50 ... 200
Stroke adjustment per end position	[mm]	15	20	
Position sensing	Via proximity sensor			
Max. repetition accuracy ¹⁾	[mm]	0.02		

1) Variation of end position for 100 successive strokes under constant operating conditions

Operating and environmental conditions				
Piston \varnothing		12	16	20
Operating pressure	[bar]	4 ... 8		
Operating medium	Filtered compressed air, lubricated or unlubricated			
Ambient temperature ¹⁾	[°C]	0 ... +60		
Noise level L_{pEq}	[dB(A)]	62	57	56

1) Note operating range of proximity sensors

Forces [N]				
Piston \varnothing		12	16	20
Theoretical force at 6 bar, advancing		51	104	158
Theoretical force at 6 bar, retracting		68	121	188

Linear modules HMPL

Technical data

FESTO

Weights [g]				
Piston Ø		12	16	20
Product weight with stroke (HMPL-...-Al)	30 mm	610	–	–
	50 mm	658	975	1 439
	80 mm	770	1 090	1 591
	100 mm	843	1 194	1 739
	125 mm	–	1 318	1 888
	160 mm	–	1499	2 179
	200 mm	–	–	2 471
Moving load with stroke (HMPL-...-Al)	30 mm	244	–	–
	50 mm	272	401	584
	80 mm	326	467	679
	100 mm	362	521	758
	125 mm	–	587	856
	160 mm	–	681	993
	200 mm	–	–	1 150

Materials

Sectional view

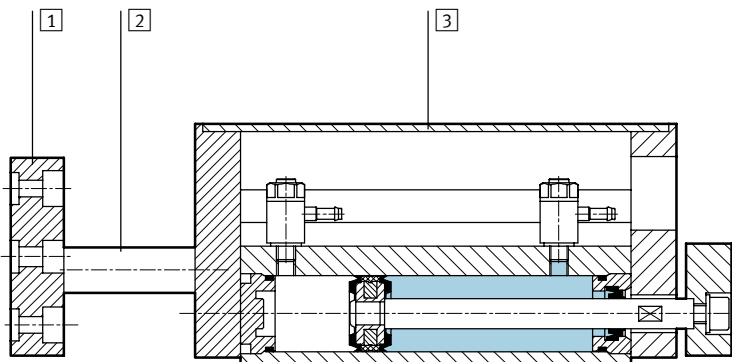

Linear module		
1	Front plate	Anodised aluminium
2	Guide rods	Tempered steel
3	End cap	Anodised aluminium
–	Reinforcing plate	Anodised aluminium
–	Seals	Perbunan, polyurethane
	Material note	Free of copper and PTFE

Handling units
Linear modules

7.1

Linear modules HMPL

Technical data



Handling units
Linear modules

7.1

Permissible torque M as a function of the stroke length l (at the front plate)

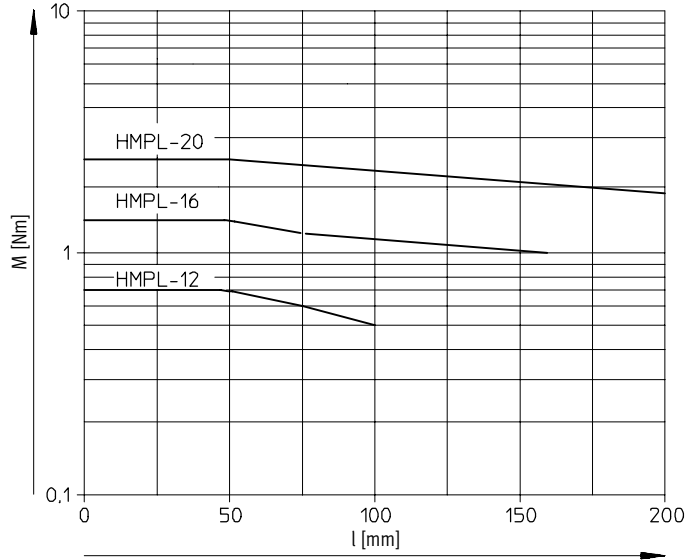
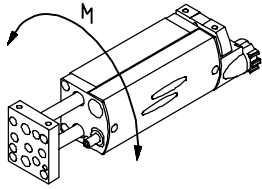

Permissible effective load F_q as a function of the stroke length l (at the front plate)

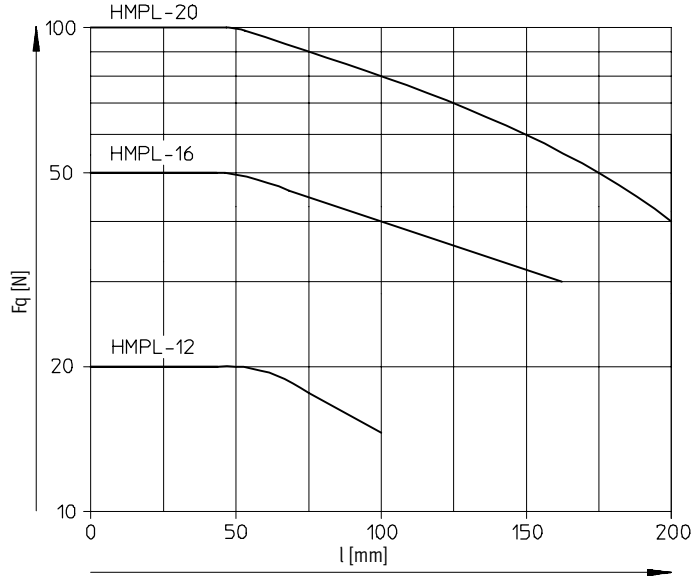
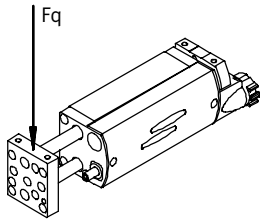

Linear modules HMPL

Technical data

Deflection/deformation f as a function of the applied load m and the position l (stroke)

Primary direction with reinforcing plate

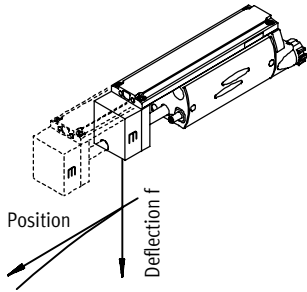

Primary direction without reinforcing plate

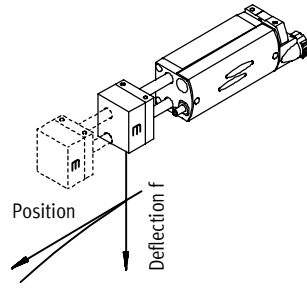

HMPL-12

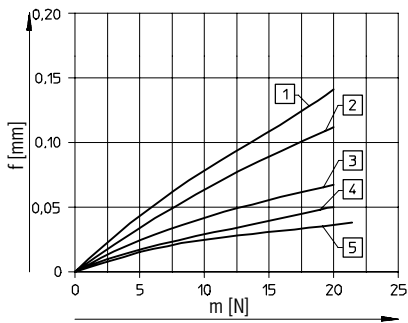

- 1 100 mm stroke
- 2 80 mm stroke
- 3 50 mm stroke
- 4 30 mm stroke
- 5 0 mm stroke

HMPL-12

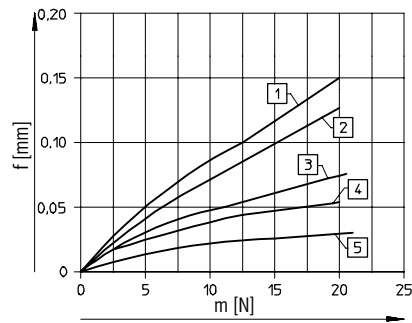

- 1 100 mm stroke
- 2 80 mm stroke
- 3 50 mm stroke
- 4 30 mm stroke
- 5 0 mm stroke

HMPL-16

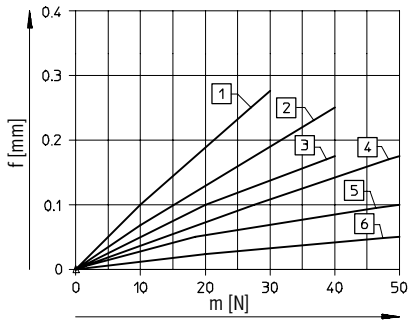

- 1 160 mm stroke
- 2 125 mm stroke
- 3 100 mm stroke
- 4 80 mm stroke
- 5 50 mm stroke
- 6 0 mm stroke

HMPL-16

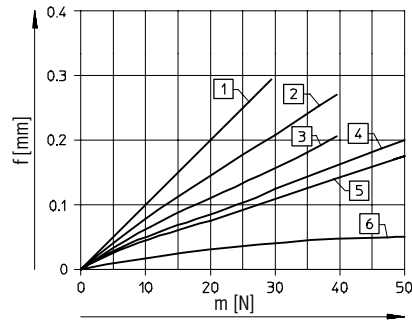

- 1 160 mm stroke
- 2 125 mm stroke
- 3 100 mm stroke
- 4 80 mm stroke
- 5 50 mm stroke
- 6 0 mm stroke

HMPL-20

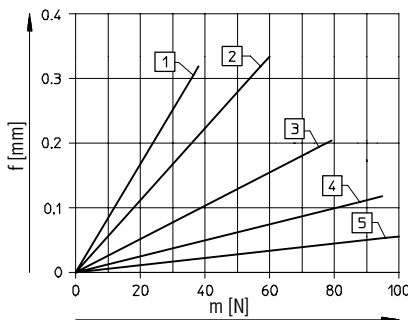

- 1 200 mm stroke
- 2 160 mm stroke
- 3 100 mm stroke
- 4 50 mm stroke
- 5 0 mm stroke

HMPL-20

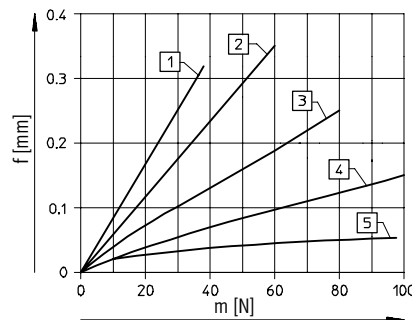

- 1 200 mm stroke
- 2 160 mm stroke
- 3 100 mm stroke
- 4 50 mm stroke
- 5 0 mm stroke

Linear modules HMPL

Technical data



Permissible horizontal travel time t at 6 bar as a function of the stroke length and the applied load m

Advancing

Retracting

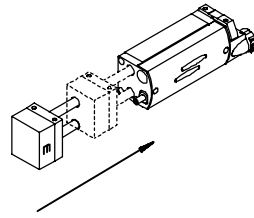
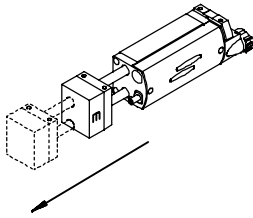

Handling units
Linear modules

7.1

HMPL-12

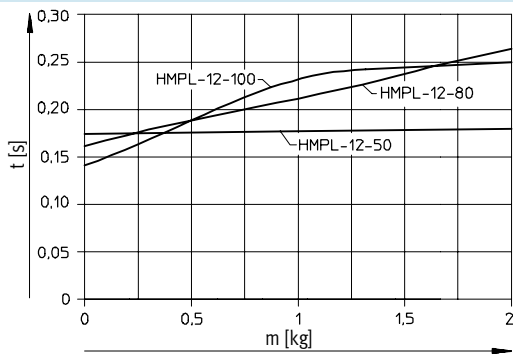

HMPL-12

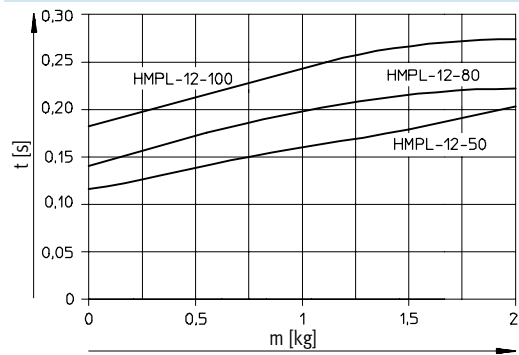

HMPL-16

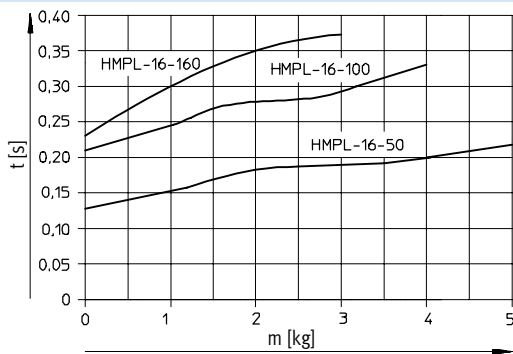

HMPL-16

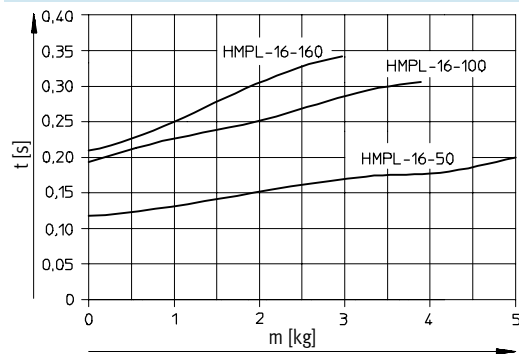

HMPL-20

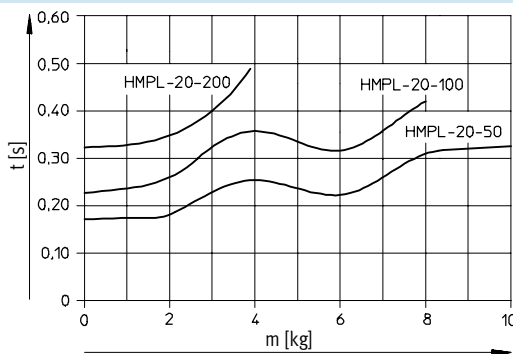

HMPL-20

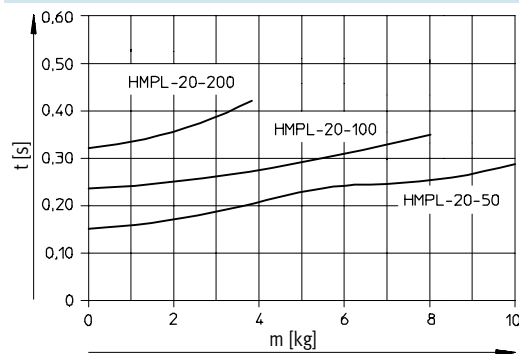

Linear modules HMPL

Technical data



Permissible vertical travel time t at 6 bar as a function of the stroke length and the applied load m

Advancing

Retracting

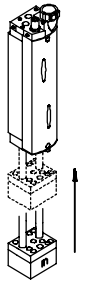
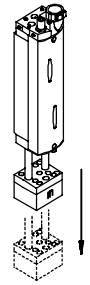

HMPL-12

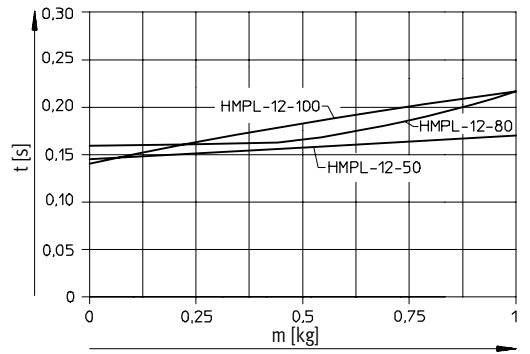

HMPL-12

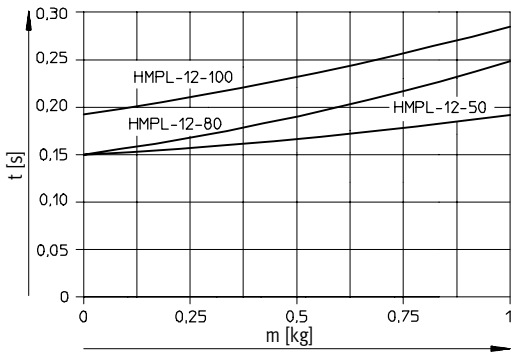

HMPL-16

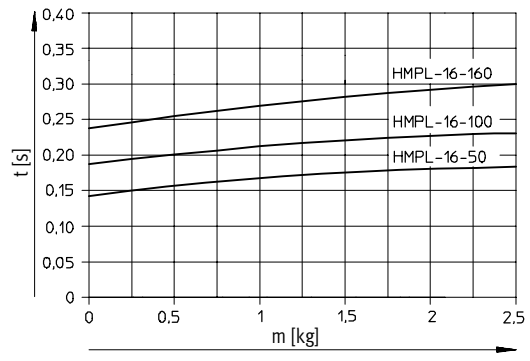

HMPL-16

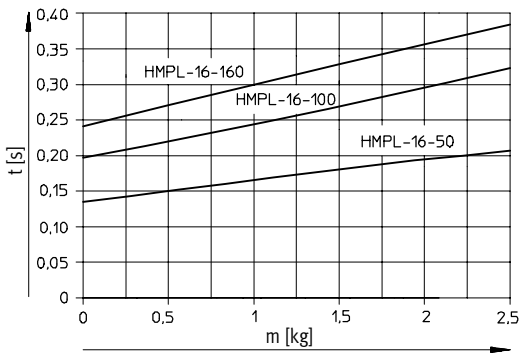

HMPL-20

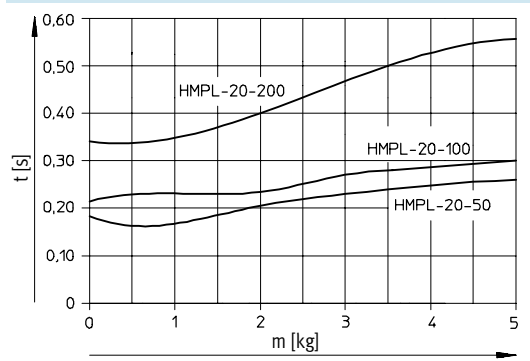

HMPL-20

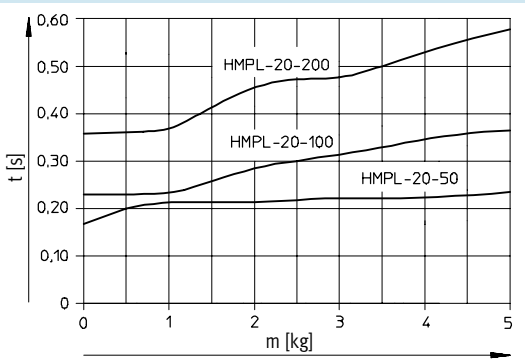

Linear modules HMPL

Technical data



Handling units
Linear modules

7.1

Dimensions

Download CAD data → www.festo.com/en/engineering

Piston Ø 12 mm

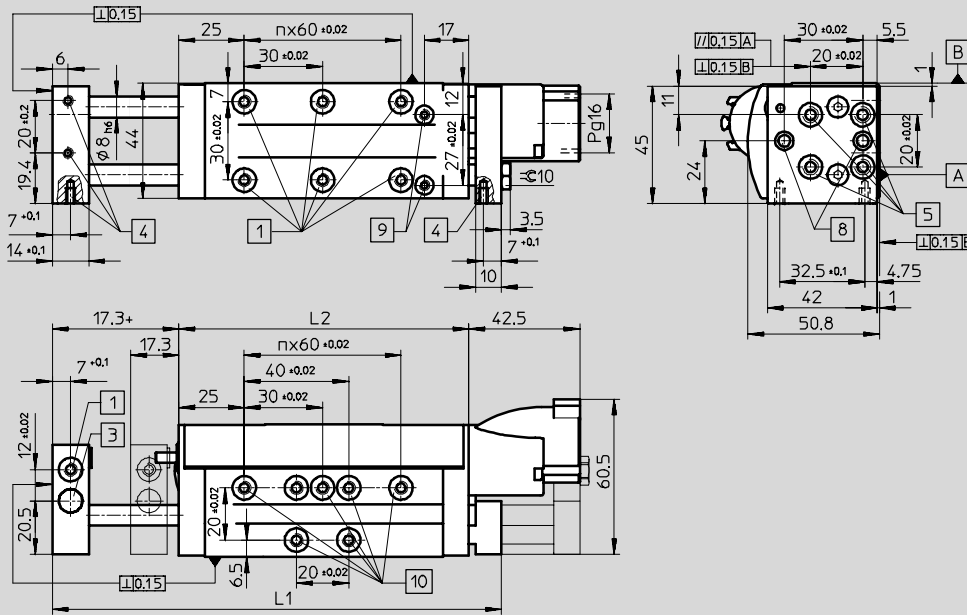

A, B = Mounting surfaces + = plus stroke length

Piston Ø 16 mm

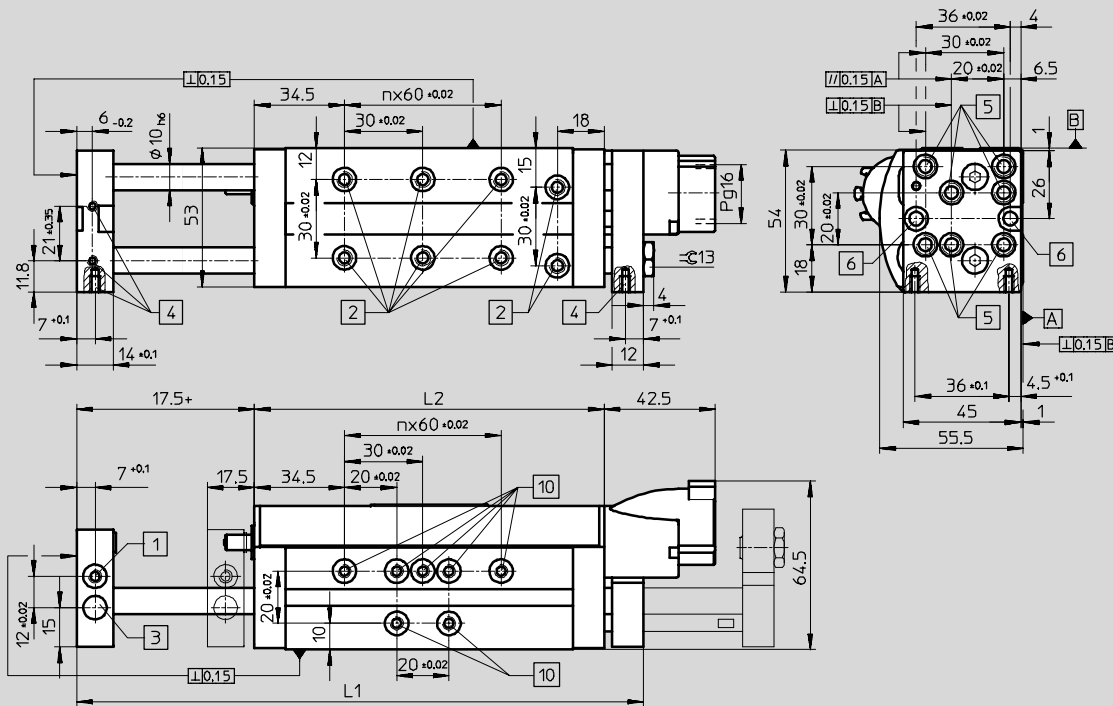

A, B = Mounting surfaces + = plus stroke length

Linear modules HMPL

Technical data



Dimensions Download CAD data → www.festo.com/en/engineering

Piston \varnothing 20 mm

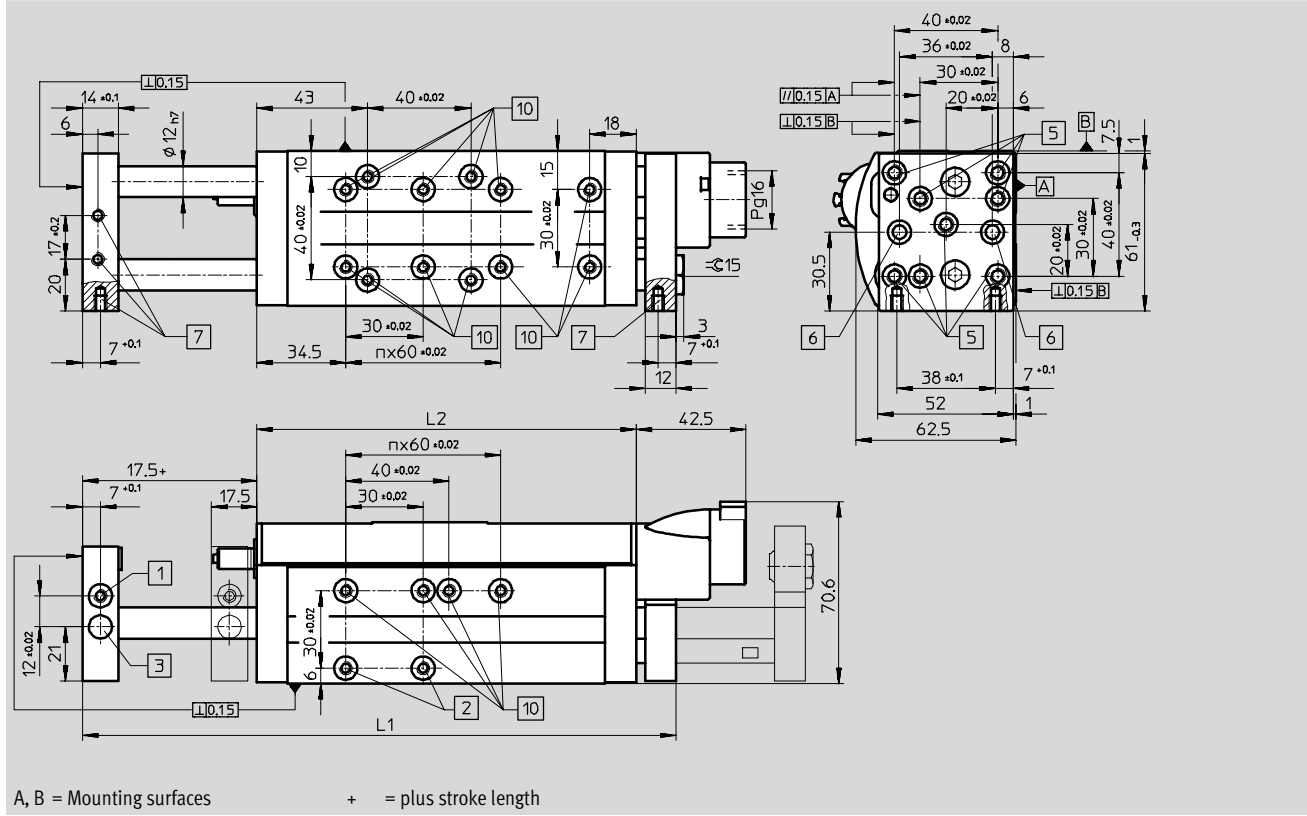

Hole patterns on the housing and the front plate

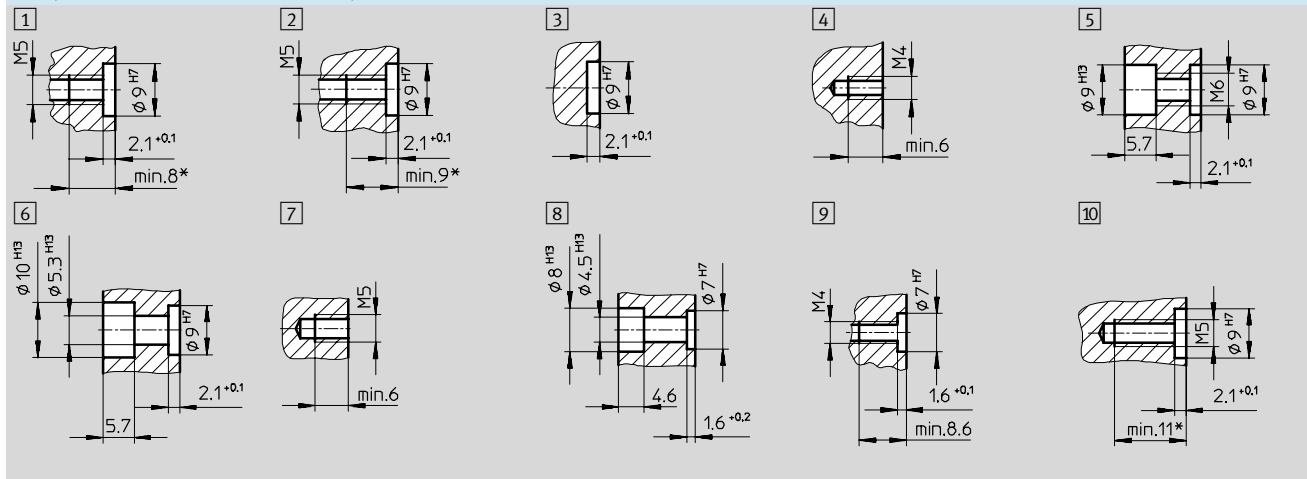

* Max. screw-in depth

\varnothing [mm]	Stroke [mm]	L1 +0.25/-0.1	L2 +0.2/-0.4	n
12	-	172	111	1
	50	202	121	
	80	262	151	
	100	302	171	2
	-	-	-	
	-	-	-	

\varnothing [mm]	Stroke [mm]	L1 +0.25/-0.1	L2 +0.2/-0.4	n
16	-	-	-	-
	50	217	134	1
	80	267	154	2
	100	307	174	
	125	357	199	
	160	427	234	-
-	-	-	-	

\varnothing [mm]	Stroke [mm]	L1 +0.25/-0.1	L2 +0.2/-0.4	n
20	-	-	-	-
	50	230	147	1
	80	267	154	2
	100	307	174	
	125	357	199	
	160	427	234	-
200	507	274	-	

Handling units
 Linear modules
7.1

Linear modules HMPL

Technical data



Mounting options – Variant A

(Y/Z axes in primary direction)

Piston Ø 20 mm

Piston Ø 16 mm

Piston Ø 12 mm

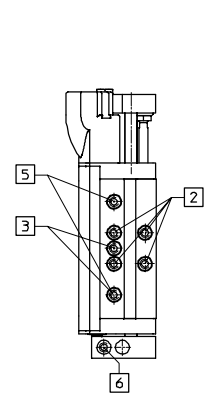
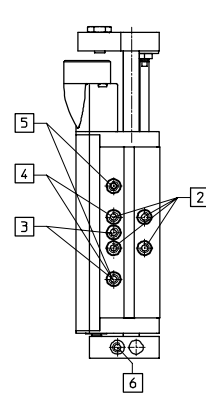
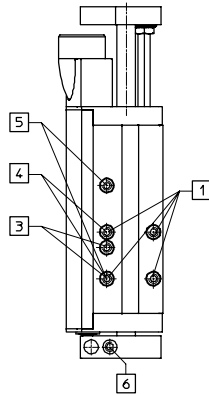
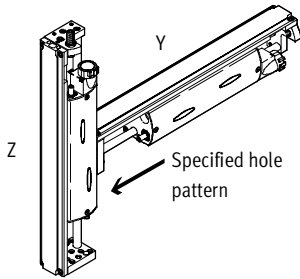

	Y axis	Z axis	Grid dimension [mm]	Mounting thread	Centring sleeve
1	HMPL-20	HMPL-20	30x30	M5	ZBH-9
2	HMPL-16	HMPL-12/-16	20x20	M5	ZBH-9
	HMPL-12	HMPL-12			
	Clamping unit HMPL-12-...-KP		20	M5	ZBH-9
3	Clamping unit HMPL-16/-20-...-KP		30	M5	ZBH-9
4	Mounting bracket HMBV		40	M5	ZBH-9
5	HMP-16/-20/-25	-	60	M5	ZBH-9
	Dovetail adapter				
	Clamping unit HMPL-...-KP for attachment to HMP front plate				
6	Clamping unit mounting		-	M5	2x ZBH-9

Mounting options – Variant B

(Y axis in primary direction)

Piston Ø 20 mm

Piston Ø 16 mm

Piston Ø 12 mm

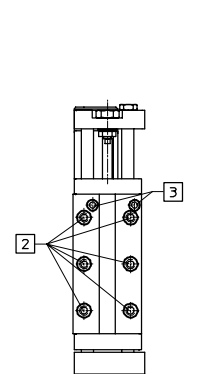
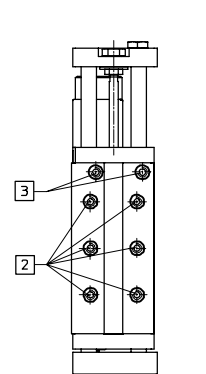
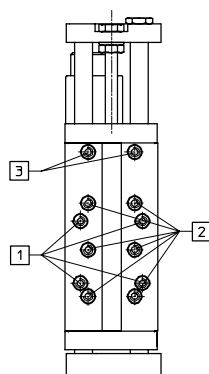
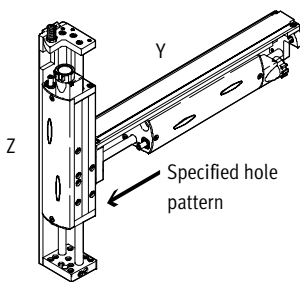

	Y axis	Z axis	Grid dimension [mm]	Mounting thread	Centring sleeve
1	HMPL-20	HMPL-20	40x40	M5	ZBH-9
	Mounting bracket HMBV				
2	HMPL-20	HMPL-12/-16/-20	30x30	M5	ZBH-9
	HMPL-16	HMPL-12/-16			
3	Active intermediate position HMPL-16/-20		-	2x M5	ZBH-9
	Active intermediate position HMPL-12			2x M4	ZBH-7

Linear modules HMPL

Technical data



Mounting options – Front plate

(Y/Z axes in primary direction)

Piston Ø 20 mm

Piston Ø 16 mm

Piston Ø 12 mm

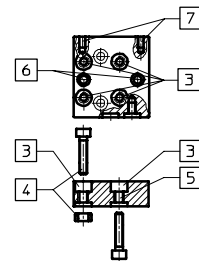
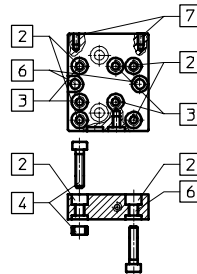
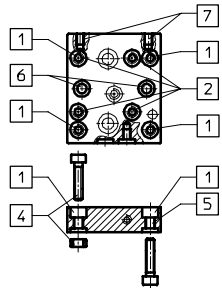

- 1) Mounting option variants
- 2) Through-holes for socket head screws

	Y axis	Z axis	Grid dimension [mm]	Mounting thread	Centring sleeve
1	HMPL-20	HMPL-20 B ¹⁾	40x40	M6	ZBH-9
2	HMPL-20	HMPL-20 A ¹⁾	30x30	M6	ZBH-9
	HMPL-16	HMPL-12/-16 B ¹⁾			
	Adapter kits HAPG-36/-37/-38 for grippers				
	Swivel/gripper unit HGDS-16/-20				
3	HMPL-16	HMPL-12/-16 B ¹⁾	20x20	M6	ZBH-9
	HMPL-12	HMPL-12 A ¹⁾			
	HMPL-12: Adapter kits HAPG-39/-60 for grippers				
	Adjustment unit HMX-1				
	Swivel/gripper unit HGDS-12				
4	Attachment of all Z axes HMPL		–	M5 ²⁾	ZBH-9
5	Individual mounting		–	M6	–
6	HMPL-12: Direct mounting DRQD-6		–	M4 ²⁾	ZBH-7
	HMPL-16/-20: Direct mounting DRQD-8/-12		–	M5 ²⁾	ZBH-9
7	HMPL-12/16: Reinforcing plate		–	2x M4	–
	HMPL-20: Reinforcing plate		–	2x M5	–

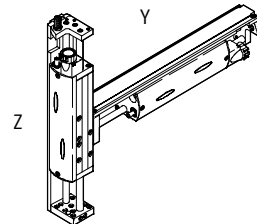
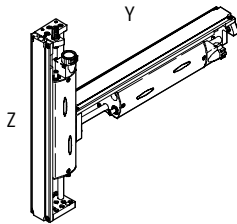

- 1) Screws and centring sleeves are not included with the drives.

HMPL/HMPL and HMP/HMPL combinations

	Y/Z axes in primary direction ¹⁾			Y axis in primary direction ¹⁾		
	HMPL-12	HMPL-16	HMPL-20	HMPL-12	HMPL-16	HMPL-20
HMPL-12	2x M5x16 2x ZBH-9	–	–	–	–	–
HMPL-16	2x M5x16 2x ZBH-9	2x M5x16 2x ZBH-9	–	2x M5x16 2x ZBH-9	2x M5x16 2x ZBH-9	–
HMPL-20	2x M5x16 2x ZBH-9	2x M5x16 2x ZBH-9	2x M5x16 2x ZBH-9	2x M5x16 2x ZBH-9	2x M5x16 2x ZBH-9	2x M5x16 2x ZBH-9
HMP-16	2x M5x22 2x ZBH-9	2x M5x22 2x ZBH-9	2x M5x22 2x ZBH-9	–	–	–
HMP-20	2x M5x22 2x ZBH-9	2x M5x22 2x ZBH-9	2x M5x22 2x ZBH-9	–	–	–
HMP-25	–	2x M5x30 2x ZBH-9	2x M5x30 2x ZBH-9	–	–	–

Linear modules HMPL

Technical data



Stop element YSRWJ

for position sensing, cushioning stroke adjustment and drive stroke adjustment.



Retrofit kit for external stop element BAE-HMPL-...

The integrated (code AI) or external (code AE) stop element can be ordered via the modular product system. The kit BAE-HMPL and additionally the stop element YSRWJ can be ordered for external retrofitting.



- 1 Soft cushioning characteristics. The cushioning stroke is adjustable
- 2 Precision end position thanks to internal, metallic inserts
- 3 Precision end-position adjustment
- 4 Position sensing via integratable proximity sensor SME-8/SMT-8

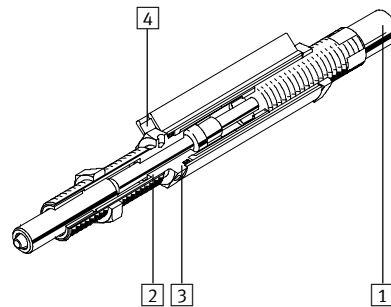

General technical data				
		YSRWJ-5-8-A	YSRWJ-7-10-A	YSRWJ-8-14-A
Piston Ø		5	7	8
Stroke	[mm]	8	10	14
Max. energy absorption	per stroke [Nm]	1	2	3
	per hour [Nm]	10000	15000	21000
Load range	[kg]	2	5	10
Reset time ¹⁾	[s]	< 0.2		
Max. residual impact force ²⁾	[N]	200	300	500

1) Increased rest times must be expected at low temperatures (0 °C).
 2) Impact force may not exceed the maximum specified value.

Operating and environmental conditions		
Piston Ø		5 7 8
Ambient temperature	[°C]	0 ... +60

Weights [g]		
Piston Ø		5 7 8
		45 75 110

Linear modules HMPL

Technical data



Dimensions – External stop element Download CAD data → www.festo.com/en/engineering
 HMPL-...-AE (code AE)

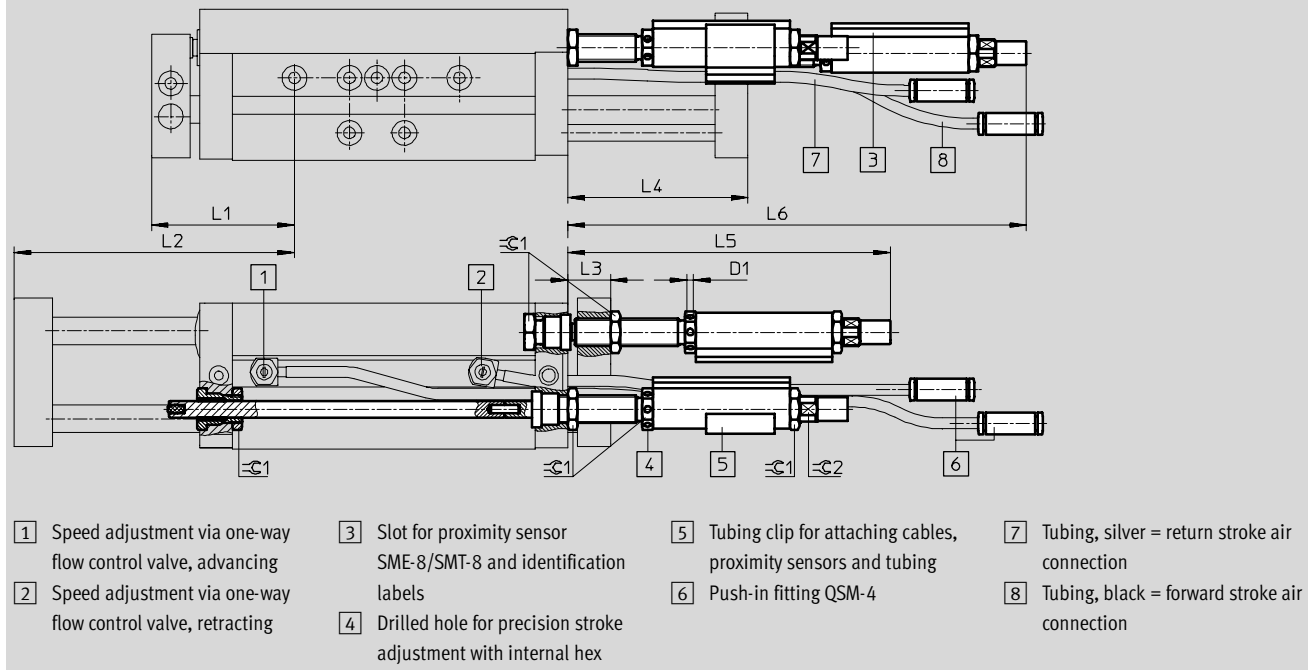

- 1 Speed adjustment via one-way flow control valve, advancing
- 2 Speed adjustment via one-way flow control valve, retracting
- 3 Slot for proximity sensor SME-8/SMT-8 and identification labels
- 4 Drilled hole for precision stroke adjustment with internal hex
- 5 Tubing clip for attaching cables, proximity sensors and tubing
- 6 Push-in fitting QSM-4
- 7 Tubing, silver = return stroke air connection
- 8 Tubing, black = forward stroke air connection

∅	Stroke	D1 ∅	L1	L2	L3	L4	L5	L6	⊖ 1	⊖ 2
[mm]	[mm]	+0.1	+15 ¹ /-0.5	+0.5/-15 ²	+15 ¹ /-0.5	+0.5/-15 ²	+2	+2/-15 ²		
12	30	2	42.3	72.3	13.7	43.7	98.9	131.1	10	7
	50			92.3		63.7		151.1		
	80			122.3		93.7		181.1		
	100			142.3		113.7		201.1		

∅	Stroke	D1 ∅	L1	L2	L3	L4	L5	L6	⊖ 1	⊖ 2
[mm]	[mm]	+0.1	+20 ¹ /-0.5	+0.5/-20 ²	+20 ¹ /-0.5	+0.5/-20 ²	+2	+2/-20 ²		
16	50	2.4	52	102	15.5	65.5	116.3	168.3	13	9
	80			132		95.5		198.3		
	100			152		115.5		218.3		
	125			177		140.5		243.3		
	160			212		175.5		278.3		

∅	Stroke	D1 ∅	L1	L2	L3	L4	L5	L6	⊖ 1	⊖ 2
[mm]	[mm]	+0.1	+20 ¹ /-0.5	+0.5/-20 ²	+20 ¹ /-0.5	+0.5/-20 ²	+2	+2/-20 ²		
20	50	2.4	52	102	15.5	65.5	134.8	210.8	15	11
	80			132		95.5		240.8		
	100			152		115.5		260.8		
	125			177		140.5		285.8		
	160			212		175.5		320.8		
	200			252		215.5		360.8		

1) Precision stroke adjustment, retracted end position
 2) Precision stroke adjustment, advanced end position

Linear modules HMPL

Technical data



Clamping unit HMPL-...-KP
not suitable for positioning

Retrofit kit for clamping unit BKP-HMPL-...

The clamping unit can be ordered via the modular product system (code KP). The kit BKP-HMPL can be ordered for retrofitting.

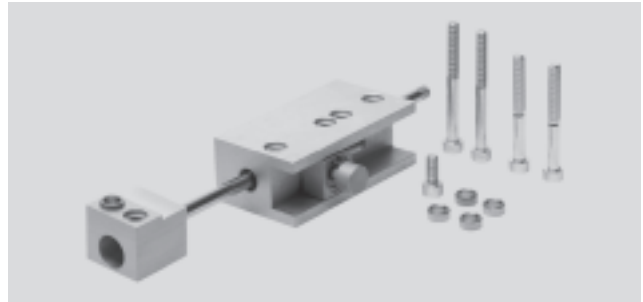

General technical data			
Piston Ø	12	16	20
Pneumatic connection ¹⁾	M3		
Max applied load, vertical [kg]	1	2.5	5
Max. holding force [N]	100		

1) Pneumatic connection is accomplished with a pre-assembled push-in fitting QSM-M3-4-1 for 4 mm tubing.

Operating and environmental conditions			
Piston Ø	12	16	20
Operating pressure ¹⁾ [bar]	4 ... 8		
Ambient temperature [°C]	0 ... +60		

1) Clamping is released within the operating pressure range.

Weights [g]			
Piston Ø	12	16	20
Product weight with stroke	30 mm	255	-
	50 mm	260	270
	80 mm	270	280
	100 mm		
	125 mm	-	290
	160 mm		
	200 mm		-
Moving load with stroke	30 mm	60	-
	50 mm	65	74
	80 mm	75	84
	100 mm		
	125 mm	-	95
	160 mm		
	200 mm		-

Linear modules HMPL

Technical data



Dimensions – Clamping unit

Download CAD data → www.festo.com/en/engineering

HMPL-...-KP (code KP)

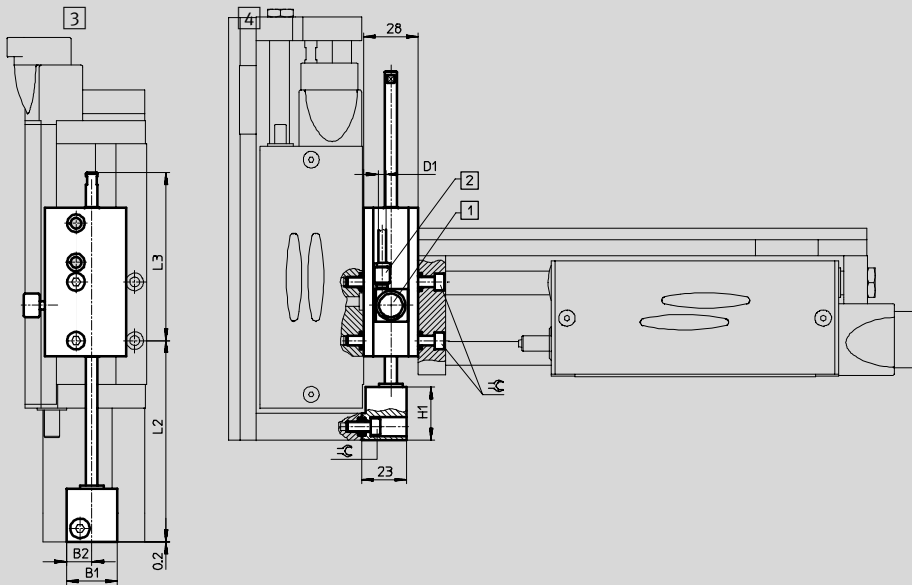

- 1 Manual override
- 2 M3 compressed air connection (push-in fitting QSM-M3-4-I for 4 mm tubing included)
- 3 Extended end position
- 4 Retracted end position

∅	Stroke	B1	B2	D1	L1	L2	L3	L4	H1	⊕
[mm]	[mm]			∅	+15 ¹⁾ /-0.5	+0.5/-15 ¹⁾	+15 ¹⁾ /-0.5	+0.5/-15 ¹⁾		
12	30	30	22	4	42.1	72.1	80	110	15.5	4
	50					92.1	85	135		
	80					122.1	105	185		
	100					142.1	85	185		

∅	Stroke	B1	B2	D1	L1	L2	L3	L4	H1	⊕
[mm]	[mm]			∅	+20 ¹⁾ /-0.5	+0.5/-20 ¹⁾	+20 ¹⁾ /-0.5	+0.5/-20 ¹⁾		
16	50	26	13	4	51.8	101.8	86.8	136.8	27	4
	80					131.8	106.8	186.8		
	100					151.8	86.8	186.8		
	125					176.8	111.8	236.8		
	160					211.8	76.8	236.8		

∅	Stroke	B1	B2	D1	L1	L2	L3	L4	H1	⊕
[mm]	[mm]			∅	+20 ¹⁾ /-0.5	+0.5/-20 ¹⁾	+20 ¹⁾ /-0.5	+0.5/-20 ¹⁾		
20	50	26	13	4	51.8	101.8	86.8	136.8	27	4
	80					131.8	106.8	186.8		
	100					151.8	86.8	186.8		
	125					176.8	111.8	236.8		
	160					211.8	76.8	236.8		
	200					251.8	86.8	286.8		

1) Stroke setting range of the HMPL axis

Linear modules HMPL

Technical data



Reinforcing plate HMPL-...-VP

Retrofit kit for reinforcing plate BVP-HMPL-...

The reinforcing plate can be ordered via the modular product system (code VP). The kit BVP-HMPL can be ordered for retrofitting.

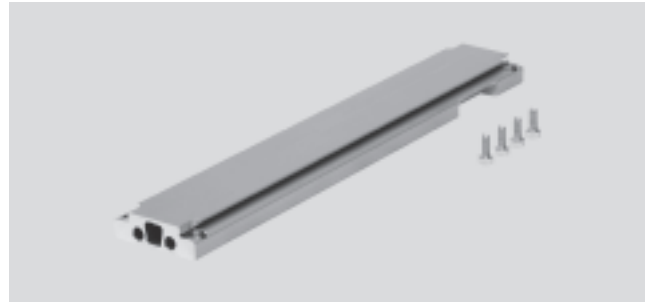

Dimensions – Reinforcing plate

Download CAD data → www.festo.com/en/engineering

HMPL-...-VP (code VP)

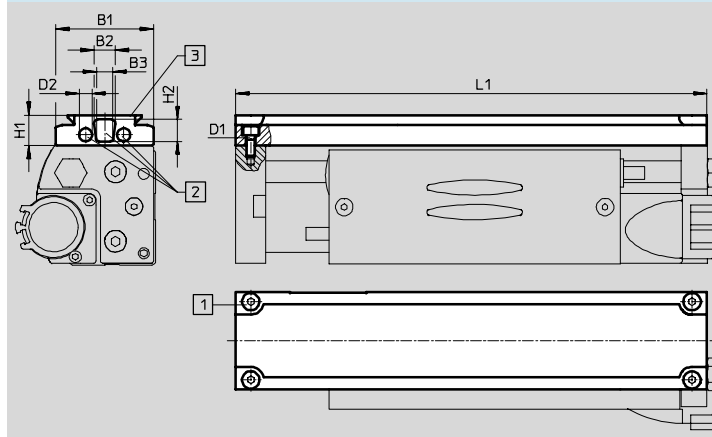

- 1) Mounting screws
- 2) Space for tubing throughfeed
- 3) Suitable for dovetail clamping

∅	Stroke	B1	B2	B3	D1	D2	H1	H2	L1	Weight
[mm]	[mm]					∅				[g]
12	30	42	11	6.2	M4	4.2	14	10	171.6	177
	50								201.6	208
	80								261.6	272
	100								301.6	314

∅	Stroke	B1	B2	B3	D1	D2	H1	H2	L1	Weight
[mm]	[mm]					∅				[g]
16	50	45	10	7.6	M4	6	14	10	216.6	240
	80								266.6	297
	100								306.6	342
	125								356.6	398
	160								426.6	478

∅	Stroke	B1	B2	B3	D1	D2	H1	H2	L1	Weight
[mm]	[mm]					∅				[g]
20	50	52	12	8.4	M5	6	14	10	229.6	283
	80								266.6	343
	100								306.6	395
	125								356.6	457
	160								426.6	547
	200								506.6	648

1) Precision stroke adjustment, retracted end position
2) Precision stroke adjustment, advanced end position

Linear modules HMPL

Technical data



External passive intermediate position

HMMP-...E

The intermediate position in the Z axis is approached with extended Y axis. A counter-stop for the stop element (in this case mounted on the reinforcing plate VP on the linear module HMPL) must be provided by the user.

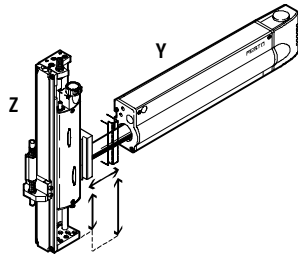

Dimensions – External passive intermediate position

Download CAD data → www.festo.com/en/engineering

HMMP-...-E

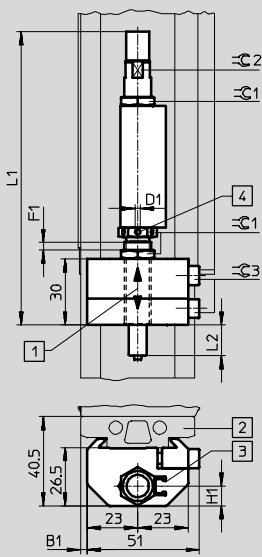

- 1 Stop position can be adjusted by sliding across the reinforcing plate. Precision end-position adjustment (F1) via thread on stop element
- 2 Reinforcing plate
- 3 Slot for proximity sensor SME-8/SMT-8
- 4 Drilled hole for precision end-position adjustment with internal hexagon socket

Type	B1	D1 +0.1	F1	H1	L1	L2	$\varnothing 1$	$\varnothing 2$	$\varnothing 3$	Weight [g]
HMMP-12-E	-1	2	15	7	97.4	8	10	7	4	115
HMMP-16-E	0.5	2.4	22	7	114.8	10	13	9	4	145
HMMP-20-E	4	2.4	35	9	133.3	14	15	11	4	205

Linear modules HMPL

Technical data



Active intermediate position HMPL-...M

Retrofit kit for active intermediate position BM-HMPL-...

The active intermediate position can be ordered via the modular product system (code M). The kit BM-HMPL can be ordered for retrofitting.

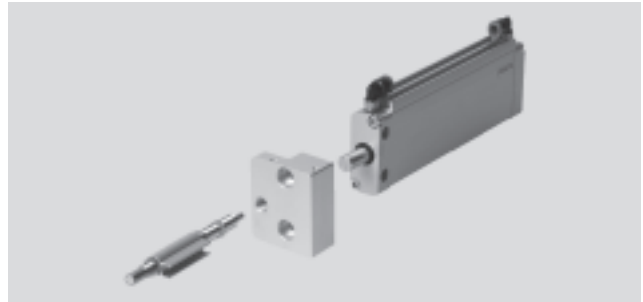

General technical data				
Piston Ø		12	16	20
Pneumatic connection		M5		
Selectable stroke range X for the intermediate position with stroke	30 mm	1 ... 29		-
	50 mm	1 ... 49		
	80 mm	1 ... 79		
	100 mm	1 ... 99		
	125 mm	-	1 ... 124	
	160 mm	-	1 ... 159	
	200 mm	-		1 ... 199
Setting range for the intermediate position	[mm]	±7.5 ¹⁾	±10 ¹⁾	

1) Valid for stroke range 7.5 or 10 mm to max. stroke -7.5 or -10 mm.

Operating and environmental conditions				
Piston Ø		12	16	20
Operating pressure ¹⁾	[bar]	4 ... 8		
Ambient temperature ¹⁾	[°C]	0 ... +60		

1) Operating pressure of the mid-position cylinder must be greater than or equal to operating pressure of the linear module HMPL.

Weights [g]				
Piston Ø		12	16	20
Product weight with 0 mm stroke		420	700	840
Product weight per 10 mm stroke		18	24	

 Note
The mid-position cylinder should be throttled during the following motion sequence: From HMPL advanced, to HMPL intermediate position.

Linear modules HMPL

Technical data



Dimensions – Active intermediate position Download CAD data → www.festo.com/en/engineering

HMPL-...M (code M)

1 Supply port, retracting
 2 Supply port, advancing
 3 Slot for proximity sensor SME-8/SMT-8
 4 Drilled hole for precision stroke adjustment with internal hex
 5 Extended position (max. stroke)
 6 Intermediate position
 7 Retracted position
 8 The mid-position cylinder should be throttled during the following motion sequence: From HMPL advanced, to HMPL intermediate position.

∅	Stroke	B1	B2	B3	D1	D2 ∅	H1	H2	L1	L2	L3	L4	L5	T1	≈C1	≈C2	≈C3	≈C4	Intermediate position Stroke X	Setting range Z ²⁾
[mm]	[mm]	±0.3	-0.6	±0.5		+0.1	±0.3	±0.3	+2/-15 ¹⁾	±0.2			+0.6							
12	30	38	20	17.5	M5	2	55	45	238	18	8	30	Stroke HMPL + 81.5 - X	6	10	7	3	4	1 ... 29	±7.5
	268								1 ... 49											
	328								1 ... 79											
	368								1 ... 99											

∅	Stroke	B1	B2	B3	D1	D2 ∅	H1	H2	L1	L2	L3	L4	L5	T1	≈C1	≈C2	≈C3	≈C4	Intermediate position Stroke X	Setting range Z ³⁾
[mm]	[mm]	±0.3	-0.6	±0.5		+0.1	±0.3	±0.3	+2/-20 ¹⁾	±0.2			+0.6							
16	50	46	24	21.5	M5	2.4	64.5	54	294	23	10	37	Stroke HMPL + 86 - X	7	13	9	4	4	1 ... 49	±10
	344								1 ... 79											
	384								1 ... 99											
	434								1 ... 124											
	504								1 ... 159											

∅	Stroke	B1	B2	B3	D1	D2 ∅	H1	H2	L1	L2	L3	L4	L5	T1	≈C1	≈C2	≈C3	≈C4	Intermediate position Stroke X	Setting range Z ³⁾
[mm]	[mm]	±0.3	-0.6	±0.5		+0.1	±0.3	±0.3	+2/-20 ¹⁾	±0.2			+0.6							
20	50	51.5	24	22	M5	2.4	64.5	61	321	23	10	37	Stroke HMPL + 86 - X	7	15	11	4	4	1 ... 49	±10
	361								1 ... 79											
	401								1 ... 99											
	451								1 ... 124											
	521								1 ... 159											
	561								1 ... 199											

1) Precision stroke adjustment, advanced end position
 2) Valid within a range of 7.5 mm to max. stroke -7.5 mm
 3) Valid within a range of 10 mm to max. stroke -10 mm
 X = Selected intermediate position

Linear modules HMPL

Technical data

Passive intermediate position HMMP-...-HMP

The intermediate position in the Z axis is approached with retracted Y axis. The counter-stop for the stop element (in this case mounted on the reinforcing plate VP on the linear module HMPL) is attached to the linear module HMP and is included in the scope of delivery.

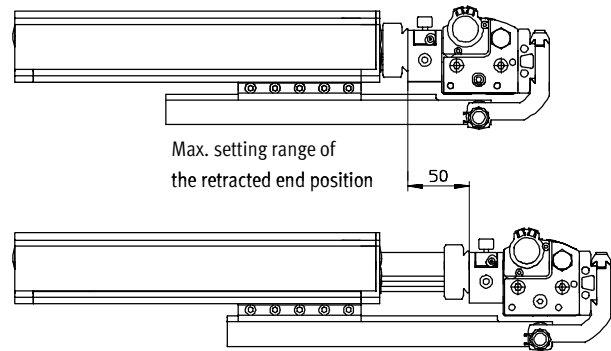
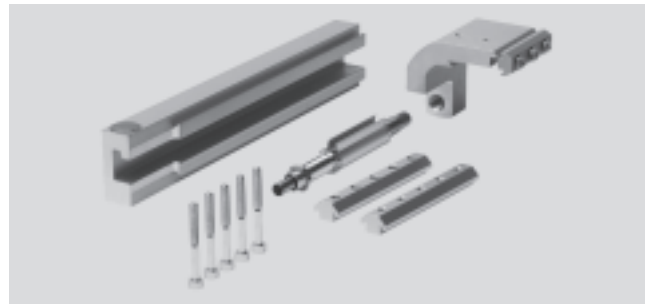
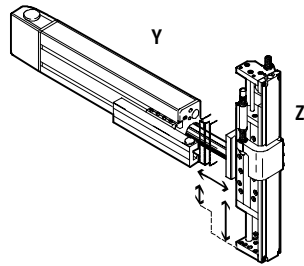

-  - Note
For reasons of rigidity, the retracted end position may not be moved forward more than 50 mm.

Linear modules HMPL

Technical data

Dimensions – Passive intermediate position Download CAD data → www.festo.com/en/engineering

HMMP-...-HMP

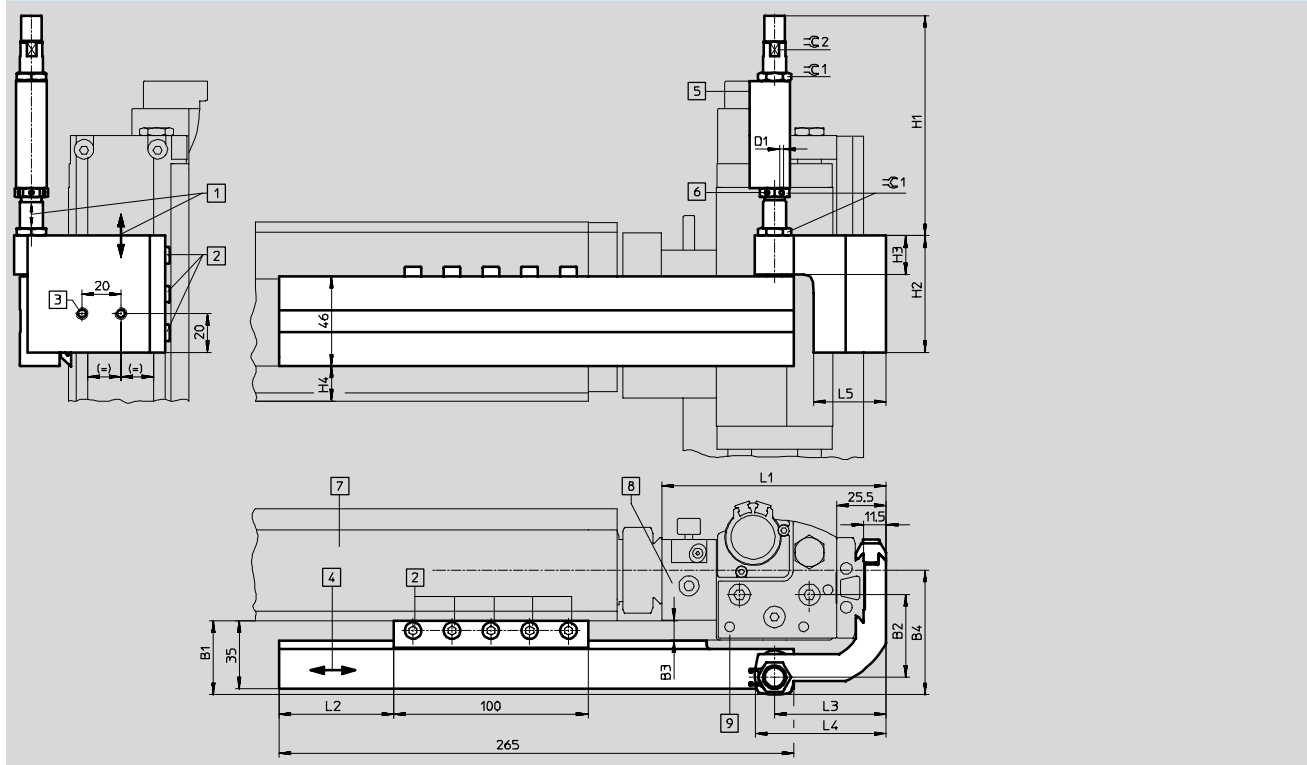

- 1 Stop position can be adjusted by sliding across the reinforcing plate
- 2 Clamping by means of M5 socket head screws with internal hexagon socket
- 3 M5 holes, 6 mm deep: for attaching adapter plate HMZAS or retaining clip MKRS
- 4 Horizontal adjusting range for stop position in the retracted end position
- 5 Slot for proximity sensor SME-8/SMT-8
- 6 Drilled hole for precision end-position adjustment with internal hexagon socket
- 7 Linear module HMP
- 8 Clamping unit HMPL-...-KP
- 9 Linear module HMPL

Type	Horizontal Y axis	Vertical Z axis	B1	B2	B3	B4	D1 ∅	H1	H2	H3	H4
HMMP-12-HMP	HMP-16	HMPL-12-...	26.5	35	0.5	52.5	2	82.4 +0.5/-12 ¹⁾	40	15	18
HMMP-16-HMP	HMP-16	HMPL-16-...	30.5	37	4	56.5	2.4	94.8 +0.5/-14 ¹⁾	60	20	18
	HMP-20		26.5		0						23.5
HMMP-20-HMP	HMP-16	HMPL-20-...	38	42.5	10	64	2.4	113.3 +0.5/-14 ¹⁾	60	20	18
	HMP-20		34		6						23.5

Type	Horizontal Y axis	Vertical Z axis	L1	L1 with KP	L2	L2 with KP	L3	L4	L5	∅ 1	∅ 2	Weight [g]
HMMP-12-HMP	HMP-16	HMPL-12-...	71.5	99.5	95	67	49.5	56.5	29.5	10	7	845
HMMP-16-HMP	HMP-16	HMPL-16-...	80.5	108.5	90	62	53.5	61.5	33.5	13	9	945
	HMP-20											
HMMP-20-HMP	HMP-16	HMPL-20-...	87.5	115.5	87	59	57.5	67.5	37.5	15	11	995
	HMP-20											

1) Setting range via stop element

Linear modules HMPL

Ordering data – Modular products



M Mandatory data					O Options					
Module No.	Drive function	Piston Ø	Stroke	Stop element	Reinforcement	Clamping unit	Active intermediate position	Proximity sensor	Accessories	Accessories
191 181	HMPL	12	30 ... 200	AI	VP	KP	...M	2A1 2A2 2A3 2A4 2A5 2A6	ZUB	...H
191 182		16		AE						...I
191 183		20		...J ...K ...V ...Z						
Ordering example										
191 182	HMPL	- 16	- 100	- AI	- VP	- KP	-	- 2A1	- ZUB	- 2H512V

Ordering table							
Size	12	16	20	Condi- tions	Code	Enter code	
M Module No.	191 181	191 182	191 183				
Drive function	Linear module				HMPL		HMPL
Piston Ø [mm]	12	16	20		-...		
Stroke [mm]	30	-	-		-30		
	50	50	50		-50		
	80	80	80		-80		
	100	100	100		-100		
	-	125	125		-125		
	-	160	160		-160		
	-	-	200		-200		
Stop element	Integrated				-AI		
	External				-AE		
O Reinforcement	Reinforcing plate (required for multi-axis operation)				-VP		
Clamping unit	Clamping cartridge (supplied separately)				-KP		
Active intermediate position [mm]	1 ... 99	1 ... 159	1 ... 199	¹	-...M		
Proximity sensor, magnetic, assembled	With cable, 2.5 m				-2A1		
	Contactless, with cable, 2.5 m, NPN				-2A2		
	Contactless, with cable, 2.5 m, PNP				-2A3		
	With plug				-2A4		
	Contactless, with plug, NPN				-2A5		
	Contactless, with plug, PNP				-2A6		
Accessories	Supplied separately				ZUB-		ZUB-
Mounting bracket	Front plate PG21, 1 ... 10				...H		
Adapter	Dovetail adapter, basic profile, 1 ... 10				...I		
Clamping component	Dovetail clamping component, 1 ... 10				...J		
Stop bolt	1 ... 10				...K		
Plug socket with cable, 2.5 m	1 ... 10				...V		
Centring sleeves (pack of 10)	10, 20, 30, 40, 50, 60, 70, 80, 90				...Z		

¹ M The dimension selected must be at least 1 mm smaller than the specified stroke length.

Transfer order code

HMPL - - - - - - - - **ZUB** -

Linear modules HMPL

Technical data

FESTO

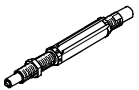
Ordering data – Stop element			
	For Ø	Part No.	Type
	[mm]		
	12	192 968	YSRWJ-5-8-A
	16	192 967	YSRWJ-7-10-A
20	192 966	YSRWJ-8-14-A	

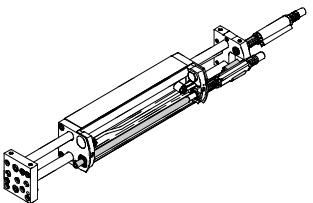
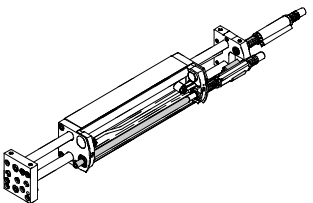
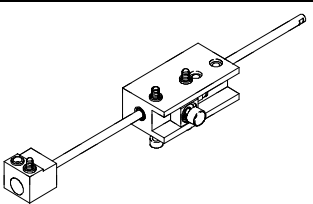
Ordering data – Retrofit kits			
	For Ø	Stroke	Part No. Type
	[mm]	[mm]	
External stop element (scope of delivery shown against a grey background)			
	12	30	193 765 BAE-HMPL-12-30
		50	193 766 BAE-HMPL-12-50
		80	193 767 BAE-HMPL-12-80
		100	193 768 BAE-HMPL-12-100
	16	50	193 769 BAE-HMPL-16-50
		80	193 770 BAE-HMPL-16-80
		100	193 771 BAE-HMPL-16-100
		125	193 772 BAE-HMPL-16-125
		160	193 773 BAE-HMPL-16-160
	20	50	193 774 BAE-HMPL-20-50
		80	193 775 BAE-HMPL-20-80
		100	193 776 BAE-HMPL-20-100
		125	193 777 BAE-HMPL-20-125
		160	193 778 BAE-HMPL-20-160
		200	193 779 BAE-HMPL-20-200
Clamping unit			
	12	30	193 110 BKP-HMPL-12-30
		50	193 111 BKP-HMPL-12-50
		80/100	193 112 BKP-HMPL-12-80/100
	16	50	193 114 BKP-HMPL-16/20-50
		80/100	193 115 BKP-HMPL-16/20-80/100
		125/160	193 116 BKP-HMPL-16/20-125/160
	20	50	193 114 BKP-HMPL-16/20-50
		80/100	193 115 BKP-HMPL-16/20-80/100
		125/160	193 116 BKP-HMPL-16/20-125/160
		200	193 117 BKP-HMPL-20-200

Linear modules HMPL

Technical data

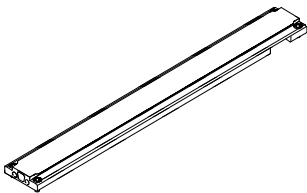
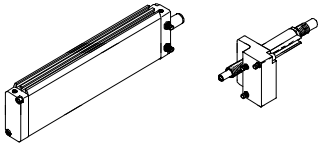

Ordering data – Retrofit kits				
	For Ø [mm]	Stroke [mm]	Part No.	Type
Reinforcing plate				
	12	30	193 369	BVP-HMPL-12-30
		50	193 370	BVP-HMPL-12-50
		80	193 371	BVP-HMPL-12-80
		100	193 372	BVP-HMPL-12-100
	16	50	193 364	BVP-HMPL-16-50
		80	193 365	BVP-HMPL-16-80
		100	193 366	BVP-HMPL-16-100
		125	193 367	BVP-HMPL-16-125
		160	193 368	BVP-HMPL-16-160
	20	50	193 358	BVP-HMPL-20-50
		80	193 359	BVP-HMPL-20-80
		100	193 360	BVP-HMPL-20-100
		125	193 361	BVP-HMPL-20-125
200		193 363	BVP-HMPL-20-200	
Active intermediate position³⁾				
	12	1 ... 99 (up to the intermediate position)	193 022	BM-HMPL-12-...¹⁾...²⁾
	16	1 ... 159 (up to the intermediate position)	193 021	BM-HMPL-16-...¹⁾...²⁾
	20	1 ... 199 (up to the intermediate position)	193 020	BM-HMPL-20-...¹⁾...²⁾
Ordering example				
Existing: HMPL-16-100-AI Desired intermediate position: Advance 25 mm Required kit: 193 021 BM-HMPL-16-100-25M				

1) Indicate stroke length of the existing HMPL linear module.

2) Indicate desired intermediate position measured from the retracted end position.

3) The mid-position cylinder should be throttled during the following motion sequence: From HMPL advanced, to HMPL intermediate position.

Linear modules HMPL

Technical data



Ordering data – External passive intermediate position

Combined with linear module HMP

The intermediate position in the Z axis is approached with extended Y axis. A counter-stop for the stop element (in this case mounted on the reinforcing plate VP on the linear module HMPL) must be provided by the user.

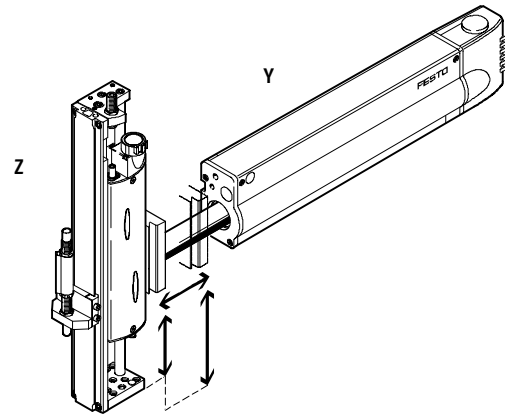

Linear module ∅ [mm]	Z axis					
	HMPL-12-... ¹⁾		HMPL-16-... ¹⁾		HMPL-20-... ¹⁾	
	Part No.	Type	Part No.	Type	Part No.	Type
Y axis						
HMP-16	196 168	HMMP-12-E	196 167	HMMP-16-E	196 166	HMMP-20-E
HMP-20	-		-		-	
HMP-25	-		-		-	
HMPL-12	196 168	HMMP-12-E	196 167	HMMP-16-E	-	
HMPL-16	-		-		-	
HMPL-20	-		-		196 166	HMMP-20-E

1) Reinforcing plate VP is required for this function, or, in the event of retrofitting, kit BVP-HMPL-...

Ordering data – Passive intermediate position

Combined with linear module HMP

The intermediate position in the Z axis is approached with retracted Y axis. The counter-stop for the stop element (in this case mounted on the reinforcing plate VP on the linear module HMPL) is attached to the linear module HMP and is included in the scope of delivery.

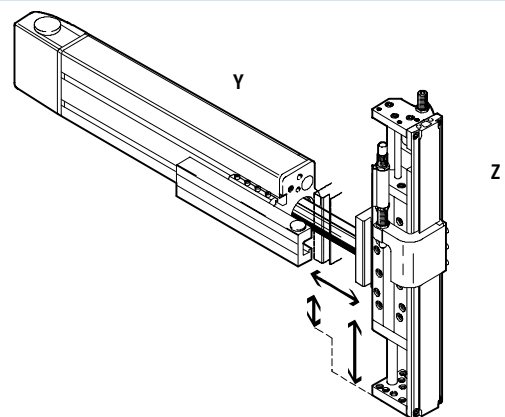

Linear module ∅ [mm]	Z axis					
	HMPL-12-... ¹⁾		HMPL-16-... ¹⁾		HMPL-20-... ¹⁾	
	Part No.	Type	Part No.	Type	Part No.	Type
Y axis						
HMP-16	193 726	HMMP-12-HMP	193 725	HMMP-16-HMP	193 724	HMMP-20-HMP
HMP-20	-		-		-	
HMP-25	-		-		-	

1) Reinforcing plate VP is required for this function, or, in the event of retrofitting, kit BVP-HMPL-...

Linear modules HMPL

Accessories



Handling units
Linear modules

7.1

Dovetail adapter HMPL-...-I (code I)

Material:
Wrought aluminium alloy
Free of copper and PTFE

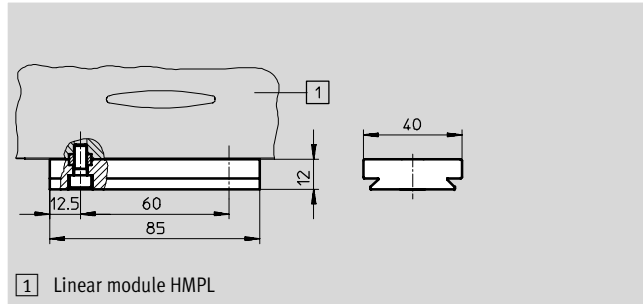

Ordering data			
For Ø	Part No.	Type	
[mm]			
12 ... 20	193 923	HMSV-46	

Clamping component HMPL-J (code J)

Material:
Wrought aluminium alloy
Free of copper and PTFE

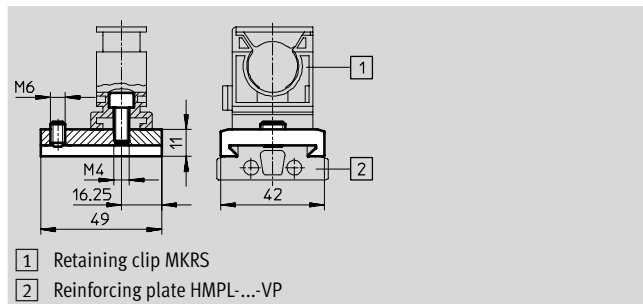

Dimensions and ordering data			
For Ø	Part No.	Type	
[mm]			
12 ... 20	193 126	HMPL-20-J	

Stop bolt HMPL-...-K (code K)

Material:
Galvanised steel
Free of copper and PTFE

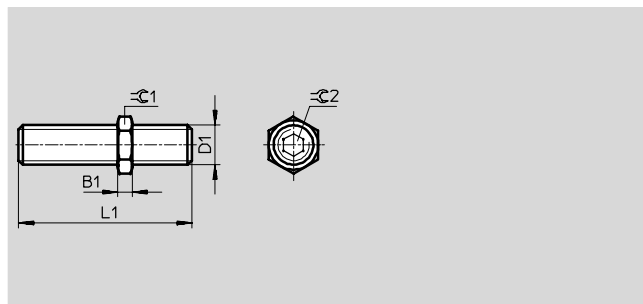

Dimensions and ordering data						
For Ø	B1	D1	L1	$\varnothing 1$	$\varnothing 2$	Part No. Type
[mm]						
12	3	M8x1	35	10	4	192 683 HMPL-12-K
16	3.5	M10x1	40	13	5	192 684 HMPL-16-K
20	4	M12x1	43	15	6	192 685 HMPL-20-K

Linear modules HMPL

Accessories



Ordering data						
	For piston \varnothing [mm]	Remarks	Order code	Part No.	Type	PU ¹⁾
Centring sleeve ZBH Technical data → 1 / 10.1-19						
	12 ... 20	For front plate	Z	150 927	ZBH-9	10
Inscription label SBS						
	12 ... 20	For labelling the linear module	-	193 125	SBS-8x10	44

1) Packaging unit quantity

Ordering data – Proximity sensor for slot type 8, magneto-resistive							Technical data → 1 / 10.2-13		
	Mounting	Switch output	Electrical connection			Cable length [m]	Part No.	Type	
			Cable	M8 plug	M12 plug				
NO contact									
	Insertable from above	PNP	3-wire	-	-	2.5	525 898	SMT-8F-PS-24V-K2,5-OE	
				-	-		525 909	SMT-8F-NS-24V-K2,5-OE	
		-	2-wire	-	-	2.5	525 908	SMT-8F-ZS-24V-K2,5-OE	
				-	-		525 899	SMT-8F-PS-24V-K0,3-M8D	
		PNP	-	3-pin	-	-	0.3	525 910	SMT-8F-NS-24V-K0,3-M8D
					-	3-pin		525 900	SMT-8F-PS-24V-K0,3-M12
	Insertable from end, flush with the cylinder profile	PNP	3-wire	-	-	2.5	175 436	SMT-8-PS-K-LED-24-B	
				-	3-pin		-	175 484	SMT-8-PS-S-LED-24-B
NC contact									
	Insertable from above	PNP	3-wire	-	-	7.5	525 911	SMT-8F-PO-24V-K7,5-OE	





Ordering data – Proximity sensor for slot type 8, magnetic reed							Technical data → 1 / 10.2-16	
	Mounting	Electrical connection			Cable length [m]	Part No.	Type	
		Cable	M8 plug					
NO contact								
	Insertable from above	3-wire	-	-	2.5	525 895	SME-8F-DS-24V-K2,5-OE	
			-	-	5.0	525 897	SME-8F-DS-24V-K5,0-OE	
		2-wire	-	-	2.5	525 907	SME-8F-ZS-24V-K2,5-OE	
			-	3-pin	0.3	525 896	SME-8F-DS-24V-K0,3-M8D	
	Insertable from end, flush with the cylinder profile	3-wire	-	-	2.5	150 855	SME-8-K-LED-24	
			-	3-pin	0.3	150 857	SME-8-S-LED-24	
		-	-	-	-	-	-	
NC contact								
	Insertable from above	3-wire	-	-	7.5	525 906	SME-8F-DO-24V-K7,5-OE	

Core Range

Linear modules HMPL

Accessories

FESTO

Ordering data – Plug sockets							Technical data → 1 / 10.2-108	
	Mounting	Switch output		Connection	Cable length [m]	Part No.	Type	
		PNP	NPN					
Straight plug socket								
	M8 locknut	■	■	3-pin	2.5	159 420	SIM-M8-3GD-2,5-PU	
					5	159 421	SIM-M8-3GD-5-PU	
	M12 locknut	■	■	3-pin	2.5	159 428	SIM-M12-3GD-2,5-PU	
					5	159 429	SIM-M12-3GD-5-PU	
Angled plug socket								
	M8 locknut	■	■	3-pin	2.5	159 422	SIM-M8-3WD-2,5-PU	
					5	159 423	SIM-M8-3WD-5-PU	
	M12 locknut	■	■	3-pin	2.5	159 430	SIM-M12-3WD-2,5-PU	
					5	159 431	SIM-M12-3WD-5-PU	

Handling units
Linear modules

7.1

 Core Range