

- **Sturdy**
- **Gripping forces of up to 700 N**
- **Reliable thanks to gripping force retention**
- **Splash-proof through use of sealing air**

T-slot grippers HGPT

Key features

At a glance

The force generated by the linear motion is translated into the gripper jaw movement via a wedge mechanism with guided motion sequence. This also guarantees synchronous movement of the gripper jaw. The virtually backlash-free slideway is realised using ground-in gripper jaws.

Flexible range of applications

- Double-acting gripper
- Compression spring for supplementary or retaining gripping forces
- For use as a single-acting gripper with only one compressed air connection
- Suitable for external and internal gripping

Gripper closed

Gripper open

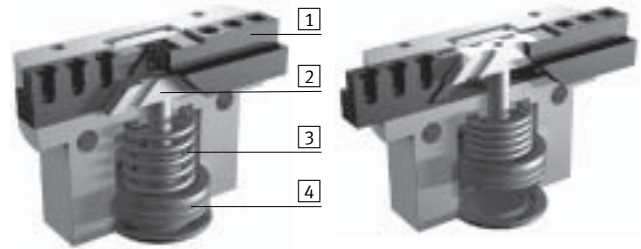

- | | |
|---|-----------------------------|
| 1 Gripper jaw | 3 Spring |
| 2 Wedge with restricted guidance | 4 Piston with magnet |

Sealing air connection

Compressed air flows past the gripper jaw when sealing air (max. 0.5 bar) is connected.

This prevents, for example, particles and soluble cutting oil from entering the gripper jaw guides.

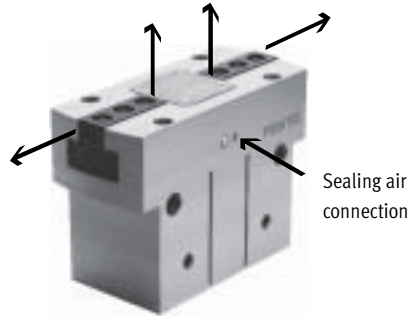

Versatile compressed air connections

Direct from the front

Via adapter plate from underneath

Mounting options

Direct mounting from above

from underneath and from the side

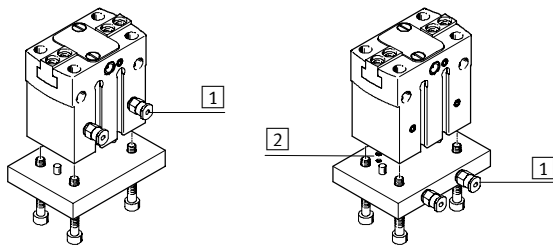

- | |
|-------------------------------------|
| 1 Compressed air connections |
| 2 O-rings |

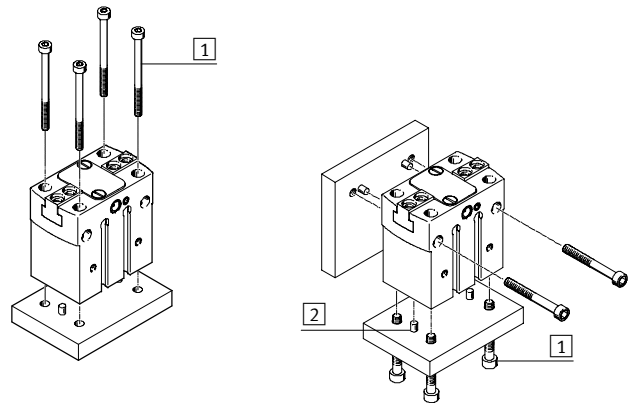

- | |
|--------------------------|
| 1 Mounting screws |
| 2 Centring pins |

 **Note**

T-slot grippers are not designed for the following application:

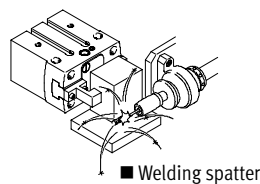

■ Welding spatter

T-slot grippers HGPT

Peripherals overview and type codes

Peripherals overview

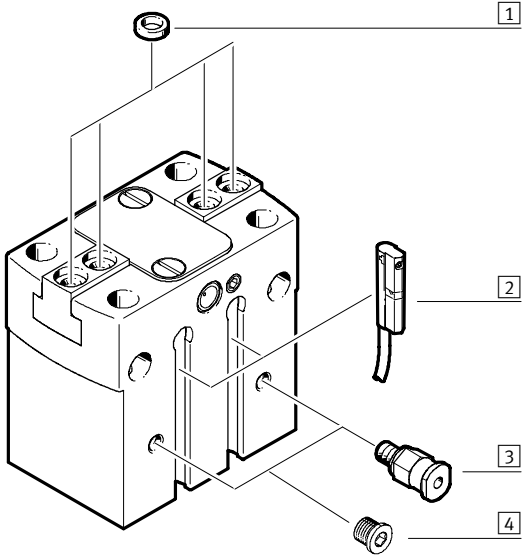

Accessories		
Type	Brief description	→ Page
1 Centring sleeve ZBH	For centring when attaching gripper fingers	1 / 7.7-33
2 Proximity sensor SME-/SMT-10	For sensing the piston position	1 / 7.7-33
3 Push-in fitting QS	For connecting compressed air tubing with standard external diameters	Volume 3
4 Blanking plug B	For sealing compressed air connections when using air connections at the front	1 / 7.7-33
- Unmachined gripper finger BUB-HGPT	Unmachined part specially matched to the gripper jaws for custom building of gripper fingers	1 / 7.7-32
-	Drive/gripper connections	Volume 5

Type codes

HGPT		16	A	G1
Type				
HGPT	T-slot gripper			
Piston Ø				
Position sensing				
A	Via proximity sensor			
Gripping force retention				
G1	Open			
G2	Closed			

T-slot grippers HGPT

Technical data

Function
Double-acting
HGPT-...-A

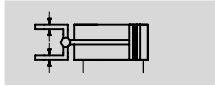

 - Piston Ø
16 ... 63 mm

 - Stroke
6 ... 32 mm

Variants
Single-acting or
with gripping force retention ...
... open HGPT-...-G1

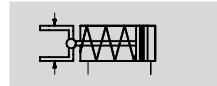

... closed HGPT-...-G2



General technical data							
Piston Ø	16	20	25	35	40	50	63
Design	Wedge mechanism Guided motion sequence						
Mode of operation	Double-acting						
Gripper function	Parallel						
Number of gripper jaws	2						
Max. applied load per external gripper finger ¹⁾ [N]	0.5	1	1.5	2	2.5	3	4
Stroke per gripper jaw [mm]	3	4	6	8	10	12	16
Pneumatic connection	M3	M3	M5	M5	M5	G $\frac{1}{8}$	G $\frac{1}{8}$
Pneumatic connection	M3	M3	M5	M5	M5	M5	M5
Sealing air							
Repetition accuracy ²⁾ [mm]	< 0.03	< 0.04					
Max. interchangeability [mm]	0.2						
Max. gripper jaw backlash ³⁾ [mm]	0.02						
Max. gripper jaw angular backlash [°]	0.1						
Max. operating frequency [Hz]	3					2	
Rotational symmetry [mm]	< Ø 0.2						
Position sensing	Via proximity sensor						
Type of mounting	Via through-hole and dowel pin Via female thread and dowel pin						
Fitting position	Any						

- 1) Valid for unthrottled operation.
- 2) End-position drift under constant conditions of use with 100 consecutive strokes in the direction of movement of the gripper jaws.
- 3) In the direction of the gripper jaw movement.

Operating and environmental conditions							
Piston Ø	16	20	25	35	40	50	63
Min. operating pressure HGPT-...-A [bar]	3						
Min. operating pressure HGPT-...-G... [bar]	5						
Max. operating pressure [bar]	8						
Operating medium	Filtered compressed air, lubricated or unlubricated						
Ambient temperature ¹⁾ [°C]	+5 ... +60						
Corrosion resistance class CRC ²⁾	2						

- 1) Note operating range of proximity sensors.
- 2) Corrosion resistance class 2 according to Festo standard 940 070
Components requiring moderate corrosion resistance. Externally visible parts with primarily decorative surface requirements which are in direct contact with a normal industrial environment or media such as coolants or lubricating agents.

T-slot grippers HGPT

Technical data

Weight [g]							
Piston Ø	16	20	25	35	40	50	63
HGPT-...-A	102	183	361	625	1209	1984	3633
HGPT-...-G1	104	186	371	645	1252	2102	3763
HGPT-...-G2	104	186	371	645	1252	2102	3763

Materials

Sectional view

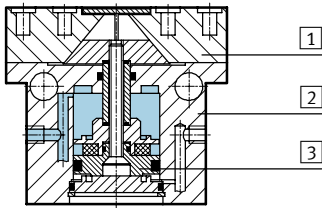

Gripper		
1	Gripper jaw	Hardened steel
2	Housing	Aluminium, coated with CompCote
3	Piston	Gunmetal (red brass)
-	Seals	Nitrile rubber
Note on materials		Free of copper, PTFE and silicone

Gripping force [N] at 6 bar per gripper jaw

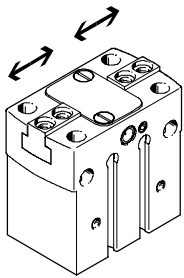

Piston Ø	16	20	25	35	40	50	63
Opening	45	70	100	220	270	430	730
Closing	45	70	100	240	290	450	750

Characteristic load values at the gripper jaws

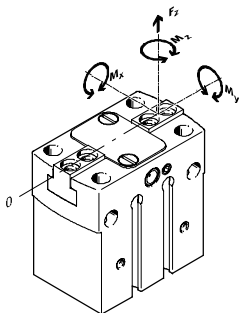

The indicated permissible forces and torques refer to a single gripper jaw. The indicated values include the lever arm, additional applied loads caused by the workpiece or external gripper

fingers, as well as forces which occur during movement. The zero coordinate line (gripper finger guide) must be taken into consideration for the calculation of torques.

Piston Ø	16	20	25	35	40	50	63	
Max. permissible force F_z	[N]	200	300	500	900	1500	2500	4000
Max. permissible torque M_x	[Nm]	10	15	30	50	80	100	140
Max. permissible torque M_y	[Nm]	7	10	25	40	60	90	120
Max. permissible torque M_z	[Nm]	5	8	15	30	40	60	80

T-slot grippers HGPT

Technical data

Mass moment of inertia [kgm²x10⁻⁴]

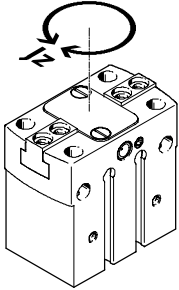

Mass moment of inertia [kgm²x10⁻⁴]
for T-slot grippers in relation to the
central axis with no load.

Piston Ø	16	20	25	35	40	50	63
HGPT-...-A	0.177	0.391	1.263	3.383	9.673	25.147	74.991
HGPT-...-G1	0.178	0.392	1.272	3.411	9.786	25.460	75.409
HGPT-...-G2	0.178	0.392	1.272	3.411	9.786	25.460	75.409

Opening and closing times [ms] at 6 bar

without external gripper fingers

with external gripper fingers

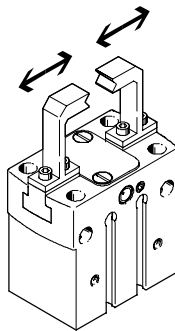
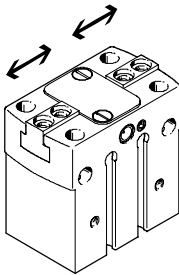

The indicated opening and closing times [ms] have been measured at room temperature and at 6 bar operating pressure with horizontally mounted gripper without external

gripper fingers. The grippers must be throttled for greater applied loads. Opening and closing times must then be adjusted correspondingly.

Piston Ø		16	20	25	35	40	50	63
without external gripper fingers								
HGPT-...-A	Opening	20	31	30	40	66	85	150
	Closing	21	31	33	40	61	76	135
HGPT-...-G1	Opening	10	26	30	39	57	65	123
	Closing	44	51	64	92	130	150	282
HGPT-...-G2	Opening	41	52	50	78	100	130	260
	Closing	21	31	30	39	61	70	130
with external gripper fingers as a function of applied load								
HGPT-...	1 N	100	–	–	–	–	–	–
	2 N	200	150	100	–	–	–	–
	3 N	300	250	200	150	100	–	–
	4 N	–	350	300	250	200	150	–
	5 N	–	–	400	350	300	250	200
	6 N	–	–	–	450	400	300	250
	8 N	–	–	–	–	–	450	400
	10 N	–	–	–	–	–	–	500

T-slot grippers HGPT

Technical data

Gripping force F_{Grip} per gripper jaw as a function of operating pressure and lever arm x

Gripping forces related to operating pressure and lever arm can be determined for the various sizes using the following graphs.

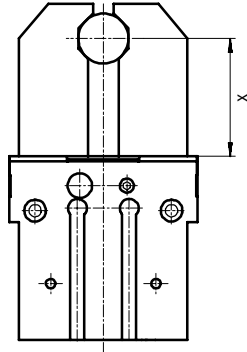

As external gripper: Closing operation

HGPT-16-A

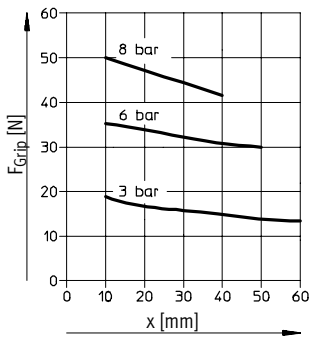

HGPT-20-A

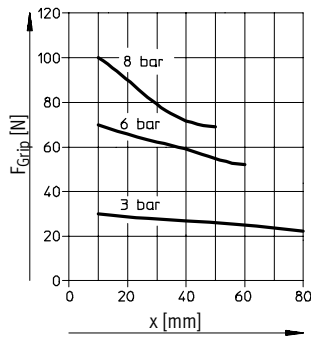

HGPT-25-A

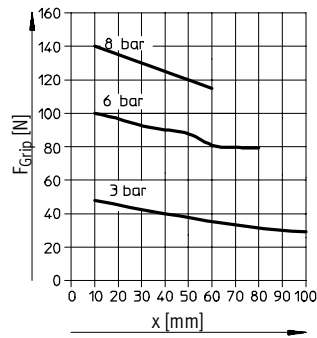

HGPT-35-A

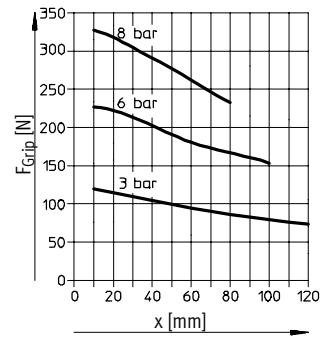

HGPT-40-A

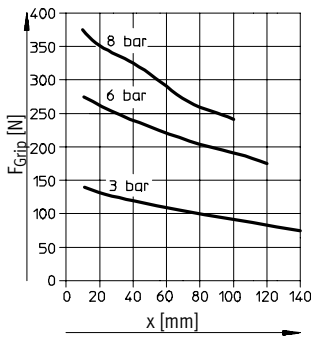

HGPT-50-A

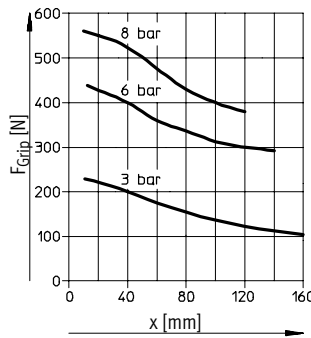

HGPT-63-A

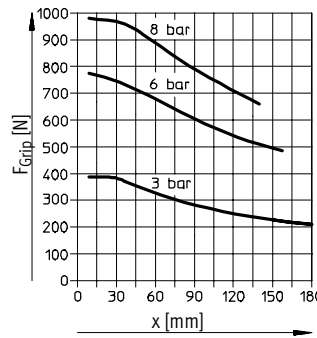

T-slot grippers HGPT

Technical data

Gripping force F_{Grip} per gripper jaw as a function of operating pressure and lever arm x
As internal gripper: Opening operation

HGPT-16-A

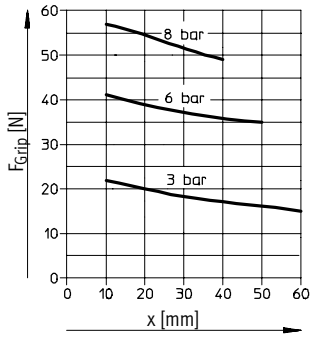

HGPT-20-A

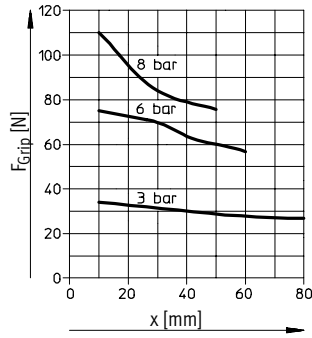

HGPT-25-A

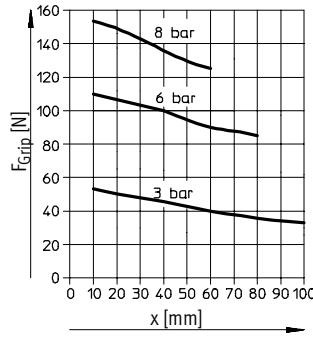

HGPT-35-A

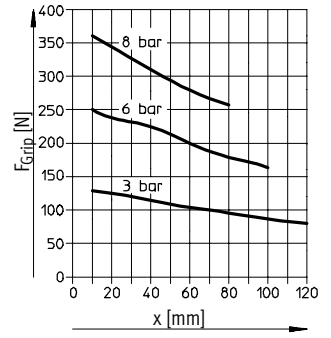

HGPT-40-A

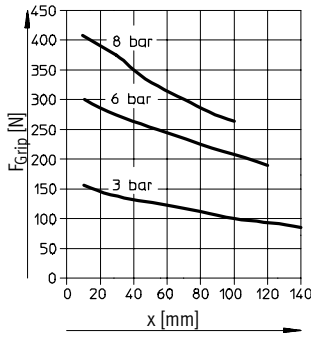

HGPT-50-A

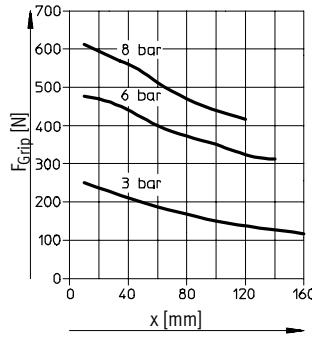

HGPT-63-A

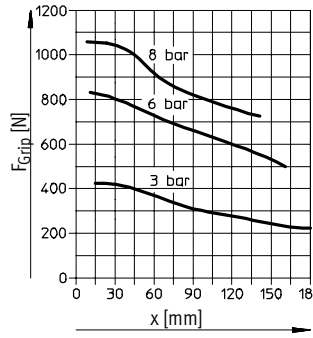

T-slot grippers HGPT

Technical data

Spring force F_{Spring} as a function of gripper size and overall stroke l

Gripping force retention for HGPT-...-G...

Spring forces F_{Spring} as a function of gripper size and overall stroke l can be determined for the various gripper types (HGPT-...-G...) using the following graphs.

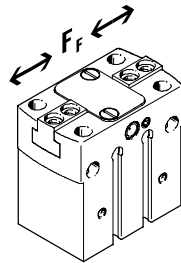

Piston \varnothing 16 ... 35

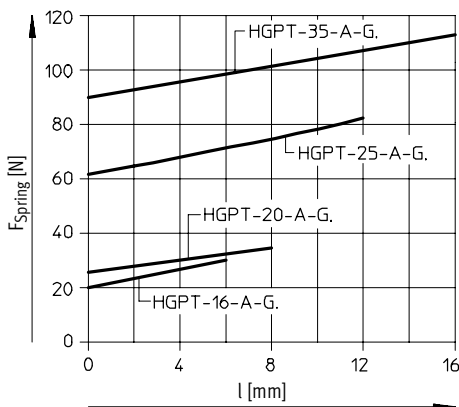

Piston \varnothing 40 ... 63

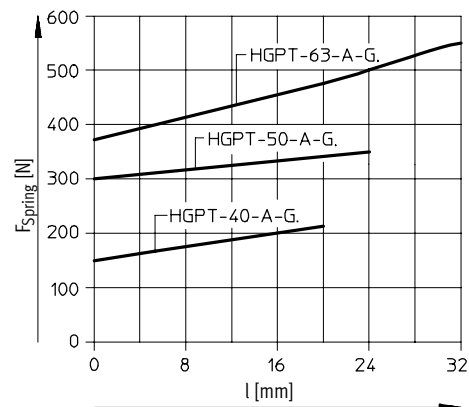

The lever arm x must be taken into consideration when determining the actual spring force F_{Stotal} . The formulae for calculating the spring force are provided in the table opposite.

Size	$F_{Stotal} =$
16	$-0.2 * x + 0.8 * F_{Spring}$
20	$-0.375 * x + 0.8 * F_{Spring}$
25	$-0.25 * x + 0.8 * F_{Spring}$
35	$-1 * x + 0.8 * F_{Spring}$
40	$-0.9 * x + 0.8 * F_{Spring}$
50	$-1.36 * x + 0.8 * F_{Spring}$
63	$-2.2 * x + 0.8 * F_{Spring}$

Determination of the actual gripping forces F_{Gr} for HGPT-...-G1 and HGPT-...-G2 depending on the application

T-slot grippers with integrated spring type HGPT-...-G1 (opening gripping force retention) and HGPT-...-G2 (closing gripping force retention) can be used as:

- single-acting grippers
- grippers with supplementary gripping force and
- grippers with gripping force retention depending on requirements.

In order to calculate available gripping forces F_{Gr} (per gripper jaw), the gripping force (F_{Grip}) and spring

force (F_{Stotal}) must be combined accordingly.

Application

Single-acting

Supplementary gripping force

Gripping force retention

■ Gripping with spring force:

$$F_{Gr} = F_{Stotal}$$

■ Gripping with pressure and spring force:

$$F_{Gr} = F_{Grip} + F_{Stotal}$$

■ Gripping with spring force:

$$F_{Gr} = F_{Stotal}$$

■ Gripping with pressure force:

$$F_{Gr} = F_{Grip} - F_{Stotal}$$

T-slot grippers HGPT

Technical data

Gripping force F_{Grip} per gripper jaw at 6 bar as a function of lever arm x and eccentricity y

Gripping forces at 6 bar dependent upon eccentric application of force and the maximum permissible off-centre point of force application can be determined for the various sizes using the following graphs.

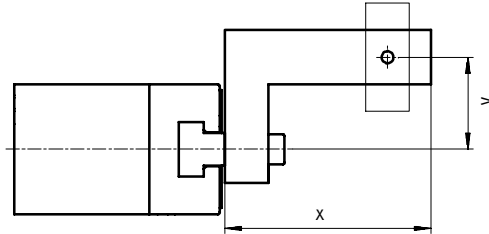

As external gripper: Closing operation

HGPT-16-A

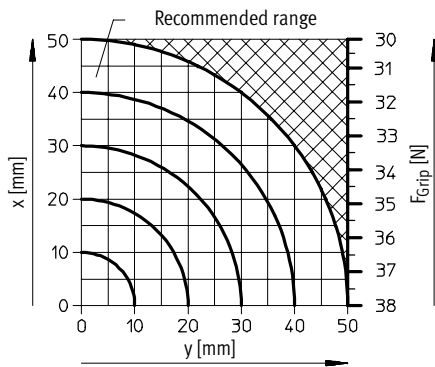

HGPT-20-A

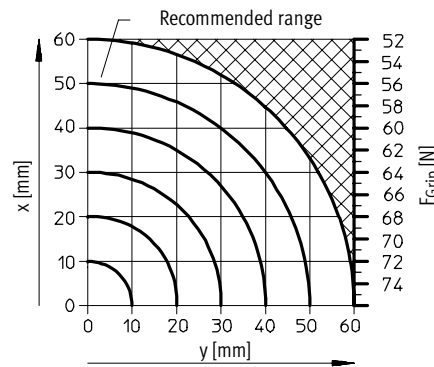

HGPT-25-A

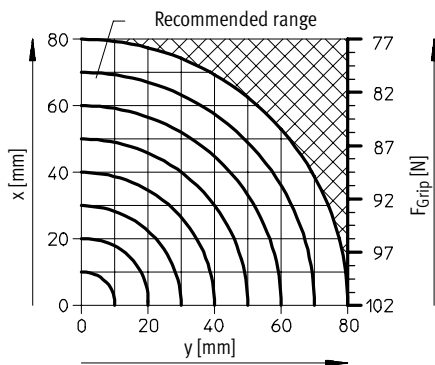

HGPT-35-A

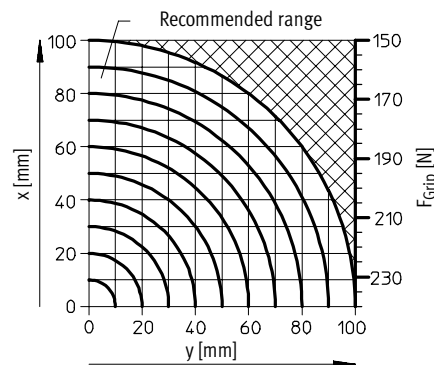

HGPT-40-A

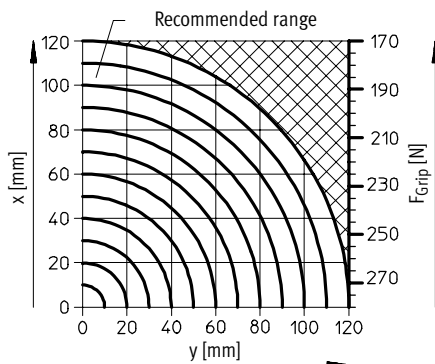

HGPT-50-A

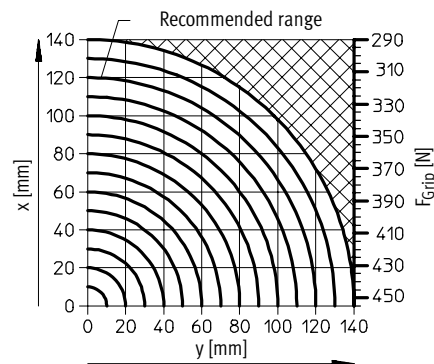

T-slot grippers HGPT

Technical data

HGPT-63-A

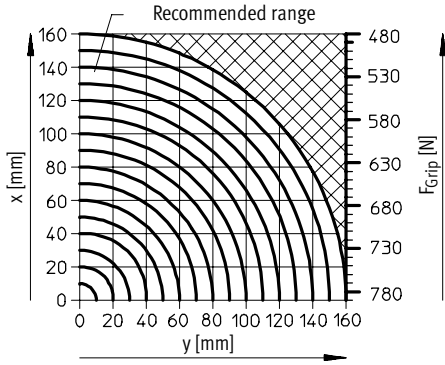

As external gripper: Opening operation

HGPT-16-A

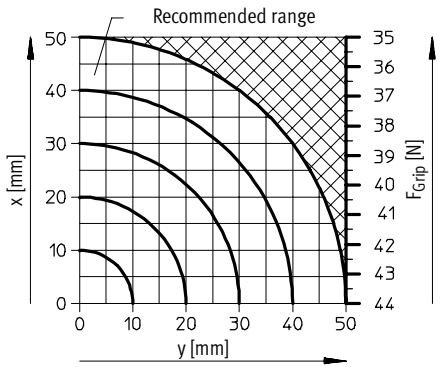

HGPT-20-A

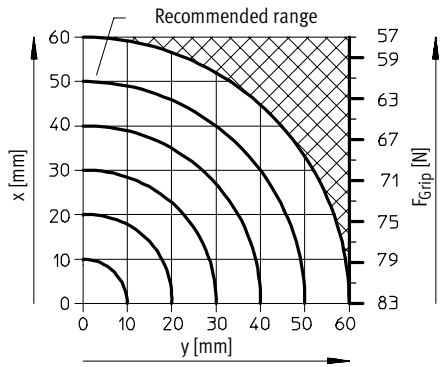

HGPT-25-A

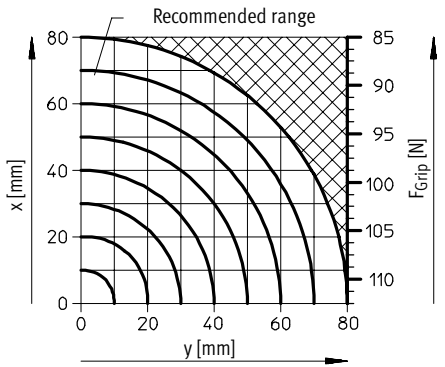

HGPT-35-A

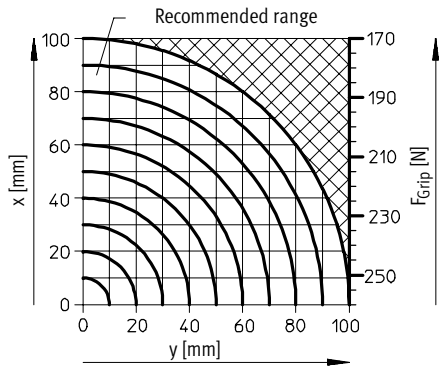

HGPT-40-A

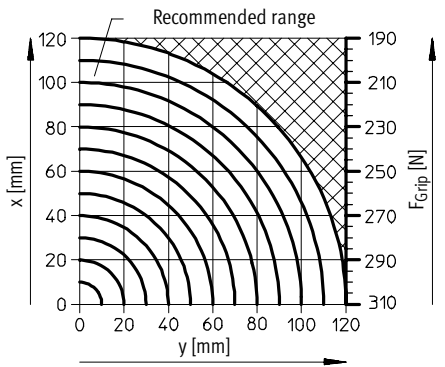

HGPT-50-A

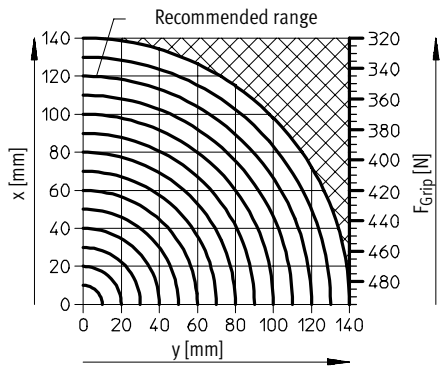

T-slot grippers HGPT

Technical data

Gripping force F_{Grip} per gripper jaw at 6 bar as a function of lever arm x and eccentricity y

HGPT-63-A

Calculation example

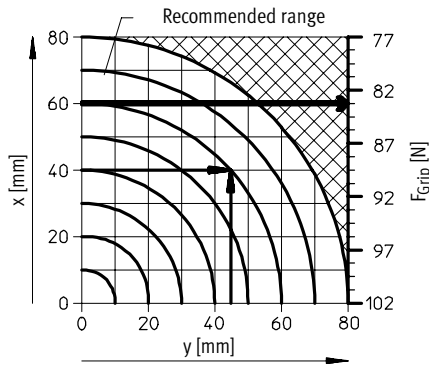
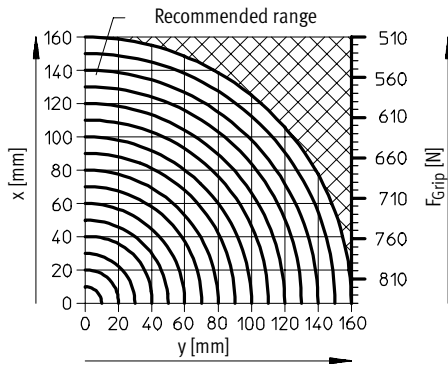

Given:

Lever arm $x = 40$ mm

Eccentricity $y = 45$ mm

To be found:

Gripping force at 6 bar

Procedure:

- Determine the intersection xy between lever arm x and eccentricity y in the graph for HGPT-25-A-...

- Draw an arc (with centre at origin) through intersection xy
 - Determine the intersection between the arc and the Y axis
 - Read the gripping force
- Result:
Gripping force = approx. 83 N

Dimensions

Download CAD data → www.festo.com/en/engineering

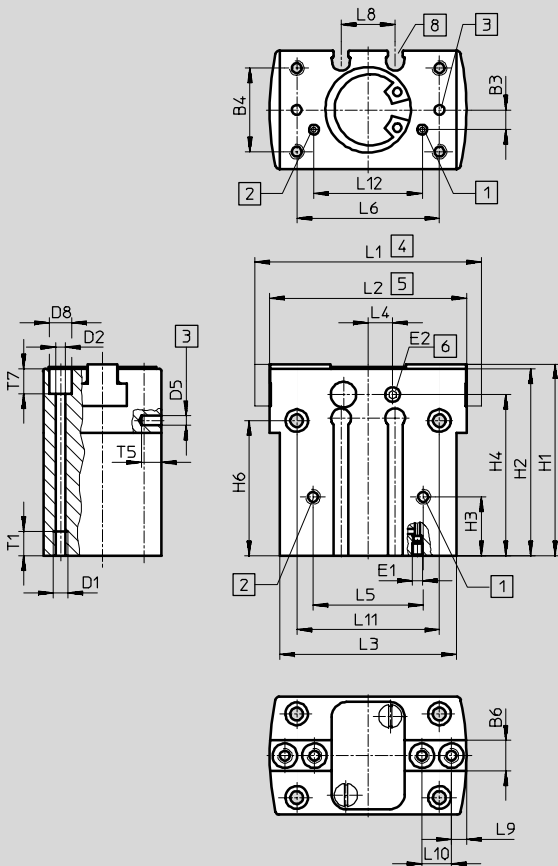

- 1 Compressed air connection opening, either on the side or bottom (bottom connection sealed on delivery)
- 2 Compressed air connection closing, either on the side or bottom (bottom connection sealed on delivery)
- 3 Hole for dowel pin (not included in scope of delivery)
- 4 Gripper jaw open
- 5 Gripper jaw closed
- 6 Sealing air connection (sealed on delivery)
- 7 Centring sleeves ZBH (4 included in scope of delivery)
- 8 Slot for proximity sensor

HGPT-50/63-...

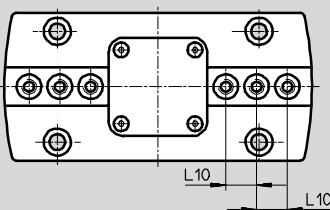

T-slot grippers HGPT

Technical data

∅	B1 ±0.05	B3 ±0.1	B4 ±0.1	B6 -0.05 -0.1	D1	D2 ∅	D3 ∅ H7/h7	D4	D5 ∅ H7	D6 ∅	D7 ∅	D8 ∅	EE
16	24	4	17	6	M3	2.6	5	M3	2	4.6+0.1	2.6	4.6+0.1	M3
20	28	7	22	6.5	M4	3.2	5	M3	3	6+0.2	3.2	6+0.2	M3
25	36	10	27	10	M5	4.2	7	M4	4	8+0.3	4.2	8+0.3	M5
35	42	9	32	12	M5	4.2	9	M6	4	10+0.3	5.3	8+0.3	M5
40	50	13	38	14	M6	5.1	9	M6	5	11+0.3	6.4	9+0.3	M5
50	60	14	45	15.5	M8	6.4	9	M6	6	13.5+0.3	8.4	11+0.3	G½
63	72	12	56	20	M8	6.4	12	M8	6	13.5+0.3	8.4	11+0.3	G½

∅	E1	E2	H1 ±0.05	H2 ±0.05	H3 ±0.1	H4	H5 -0.3	H6 ±0.02 ¹⁾ ±0.1 ²⁾	L1 ±0.5	L2 ±0.5	L3 ±0.1	L4	L5 ±0.1	L6 ±0.02 ¹⁾ ±0.1 ²⁾
16	M2	M3	39	38	12	33.7	1.2	27.5	46	40	35.8	3.8	22.4	29
20	M3	M3	46	45	15	37	1.2	24	58	50	44	0	28	35
25	M3	M5	57	56	20	46	1.4	34	76	64	52	0	28	42
35	M4	M5	67	66	28	53	1.9	38	96	80	64	0	40	52
40	M5	M5	83	82	36	68	1.9	53	120	100	80	0	48	66
50	M5	M5	97	96	30	78	1.9	61	149	125	100	0	56	82
63	M5	M5	117	116	26	92	2.4	67	192	160	125	0	74	100

∅	L7 ±0.02	L8 +0.1	L9 ±0.02 ¹⁾ ±0.1 ²⁾	L10 ±0.02 ¹⁾ ±0.1 ²⁾	L11 ±0.1	L12 ±0.1	T1 min.	T2 +0.1	T3 min.	T4 min.	T5 min.	T6	T7 +0.2
16	20	11	3	6	29	22	5	1.3	4	5	4	15	24
20	24	18	4	8	35	24	6	1.3	4	5	4	19	11
25	20	17	5	12	42	28	10	1.6	4	5	4	24	16
35	40	24	6	15	52	40	10	2.1	6	10	4	27	19
40	50	32	10	18	66	44	12	2.1	6	10	6	33	20
50	60	32	10	12.5	82	56	12	2.1	8	10	8	43	23
63	76	34	10	18	100	70	12	2.6	10	12	10	55	35

1) For centring
2) For through-hole

T-slot grippers HGPT

Technical data and accessories

Ordering data							
Piston \varnothing [mm]	Double-acting without compression spring		Single-acting or with gripping force retention				
	Part No.	Type	open		closed		
	Part No.	Type	Part No.	Type	Part No.	Type	
16	535 858	HGPT-16-A	535 859	HGPT-16-A-G1	535 860	HGPT-16-A-G2	
20	535 861	HGPT-20-A	535 862	HGPT-20-A-G1	535 863	HGPT-20-A-G2	
25	535 864	HGPT-25-A	535 865	HGPT-25-A-G1	535 866	HGPT-25-A-G2	
35	535 867	HGPT-35-A	535 868	HGPT-35-A-G1	535 869	HGPT-35-A-G2	
40	535 870	HGPT-40-A	535 871	HGPT-40-A-G1	535 872	HGPT-40-A-G2	
50	535 873	HGPT-50-A	535 874	HGPT-50-A-G1	535 875	HGPT-50-A-G2	
63	535 876	HGPT-63-A	535 877	HGPT-63-A-G1	535 878	HGPT-63-A-G2	

Accessories

Unmachined gripper finger

BUB-HGPT

(Scope of delivery: 2 pcs.)

Material:
Aluminium

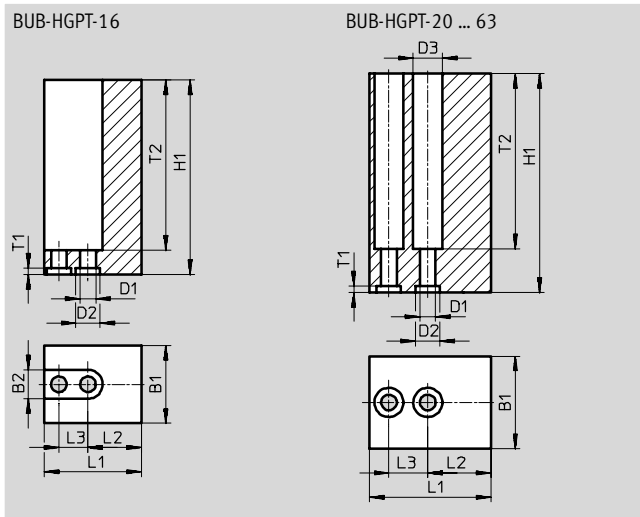

Dimensions and ordering data							
For \varnothing [mm]	B1	B2	D1 \varnothing H13	D2 \varnothing H8	D3 \varnothing +0.22	H1 ± 0.05	L1 ± 0.05
16	16	6	3.2	5	-	40	20
20	19	-	3.2	5	6	45	25
25	24	-	4.3	7	8	60	32
35	28	-	6.4	9	11	70	40
40	34	-	6.4	9	11	75	50
50	40	-	6.4	9	11	100	62.5
63	50	-	8.4	12	13.5	120	80



For \varnothing [mm]	L2 $\pm 0.02^{1)}$ $\pm 0.1^{2)}$	L3 $\pm 0.01^{1)}$ $\pm 0.1^{1)}$	T1 +0.1	T2	Weight per unmachined grripper finger [g]	Part No.	Type
16	11	6	1.3	35	28	537 198	BUB-HGPT-16
20	13	8	1.3	36	53	537 199	BUB-HGPT-20
25	15	12	1.6	51	112	537 200	BUB-HGPT-25
35	19	15	2.1	61	182	537 201	BUB-HGPT-35
40	22	18	2.1	71	312	537 202	BUB-HGPT-40
50	27.5	25	2.1	91	638	537 203	BUB-HGPT-50
63	34	36	2.6	110	1 230	537 204	BUB-HGPT-63

1) For centring
2) For through-hole





T-slot grippers HGPT





Accessories



FESTO

Ordering data – Centring sleeve				Technical data → 1 / 10.1-3		
	For piston Ø [mm]	Weight [g]	Part No.	Type	PU ¹⁾	
Centring sleeve						
	16, 20	1	189 652	ZBH-5	10	
	25	1	186 717	ZBH-7	10	
	35, 40, 50	1	150 927	ZBH-9	10	
	63	1	189 653	ZBH-12	10	
Blanking plug						
	16, 20	0.6	30 979	B-M3-S9	10	
	25, 35, 40	1	174 308	B-M5-B	10	
	50, 63	5	3 568	B-1/8	10	

1) Packaging unit quantity

Ordering data – Proximity sensors for slot type 10, magneto-resistive							Technical data → 1 / 10.2-47		
	Assembly	Switch output	Electrical connection		Cable length [m]	Connection direction	Part No.	Type	
			Cable	Plug M8					
NO contact									
	Insertable from above	PNP	3-core	–	2.5	In-line	525 915	SMT-10F-PS-24V-K2,5L-OE	
			–	3-pin	0.3	In-line	525 916	SMT-10F-PS-24V-K0,3L-M8D	
			–	3-pin	0.3	Lateral	526 675	SMT-10F-PS-24V-K0,3Q-M8D	
	Insertable from end	PNP	–	3-pin	0.3	In-line	173 220	SMT-10-PS-SL-LED-24	
			3-core	–	2.5	In-line	173 218	SMT-10-PS-KL-LED-24	

Ordering data – Proximity sensors for slot type 10, magnetic reed							Technical data → 1 / 10.2-50		
	Assembly	Electrical connection		Cable length [m]	Connection direction	Part No.	Type		
		Cable	Plug M8						
NO contact									
	Insertable from above	–	3-pin	0.3	In-line	525 914	SME-10F-DS-24V-K0,3L-M8D		
		3-core	–	2.5	In-line	525 913	SME-10F-DS-24V-K2,5L-OE		
		2-core	–	2.5	In-line	526 672	SME-10F-ZS-24V-K2,5L-OE		
	Insertable from end	–	3-pin	0.3	In-line	173 212	SME-10-SL-LED-24		
		3-core	–	2.5	In-line	173 210	SME-10-KL-LED-24		

Ordering data – Plug sockets							Technical data → 1 / 10.2-100		
	Assembly	Switch output		Connection	Cable length [m]	Part No.	Type		
		PNP	NPN						
Straight socket									
	Union nut M8	■	■	3-pin	2.5	159 420	SIM-M8-3GD-2,5-PU		
		■	■		5	159 421	SIM-M8-3GD-5-PU		
Angled socket									
	Union nut M8	■	■	3-pin	2.5	159 422	SIM-M8-3WD-2,5-PU		
		■	■		5	159 423	SIM-M8-3WD-5-PU		

 Core Range

