



- Sturdy
- Gripping forces of up to 754 N
- Reliable
- Space-saving

Long-stroke grippers HGPL

Key features

At a glance

- **Space-saving and suitable for high forces**
 - Two parallel and opposing pistons move the gripper jaws directly and without loss of force
- **Reliable**
 - A pinion that synchronises the movement of both gripper jaws ensures controlled, precise and centred gripping
 - The space-saving design of the parallel gripper jaws permits a long guide length for the gripper jaws
- **Sturdy**
 - The T-slot in combination with a long guide length allows the gripper jaws to withstand high forces and torques
- **Flexible range of applications**
 - Double-acting gripper suitable for external and internal gripping.
 - Versatile mounting options and compressed air connections
 - Opening stroke can be adjusted to optimise time

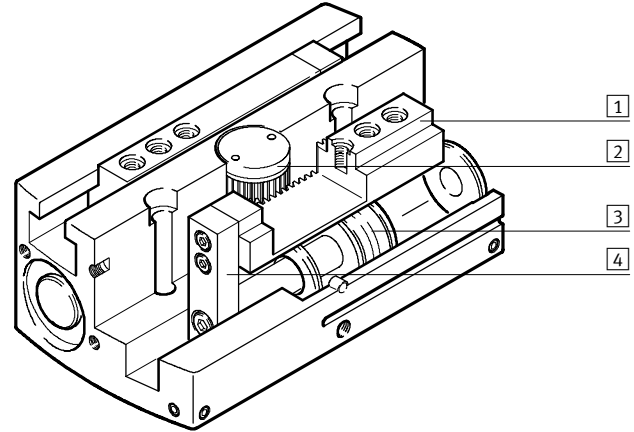

- 1 Gripper jaw
- 2 Synchronising gear
- 3 Piston with magnet
- 4 Driver

Versatile compressed air connections

Direct from the front

Via adapter plate from underneath

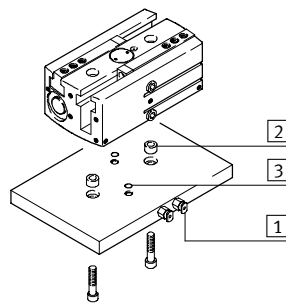
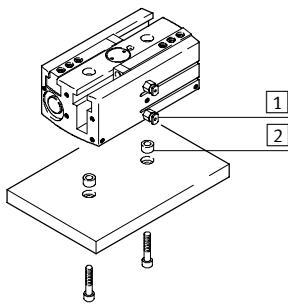

- 1 Compressed air connections
- 2 Centring sleeves
- 3 O-rings

Mounting options

Direct mounting from above

from underneath

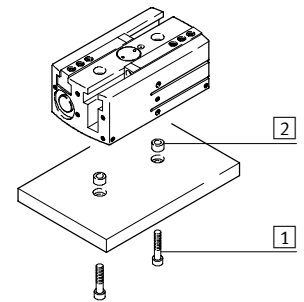
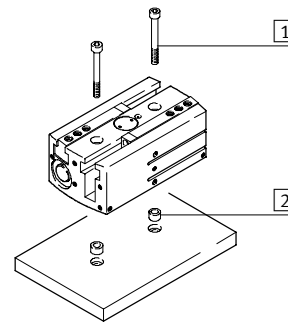

- 1 Mounting screws
- 2 Centring sleeves

 Note

Long-stroke grippers are not designed for the following or similar applications:

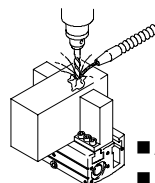

- Aggressive media
- Machining

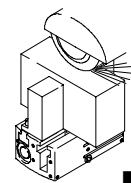

- Grinding dust

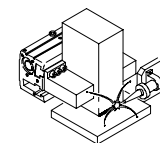

- Welding spatter

Long-stroke grippers HGPL

Peripherals overview and type codes

Peripherals overview

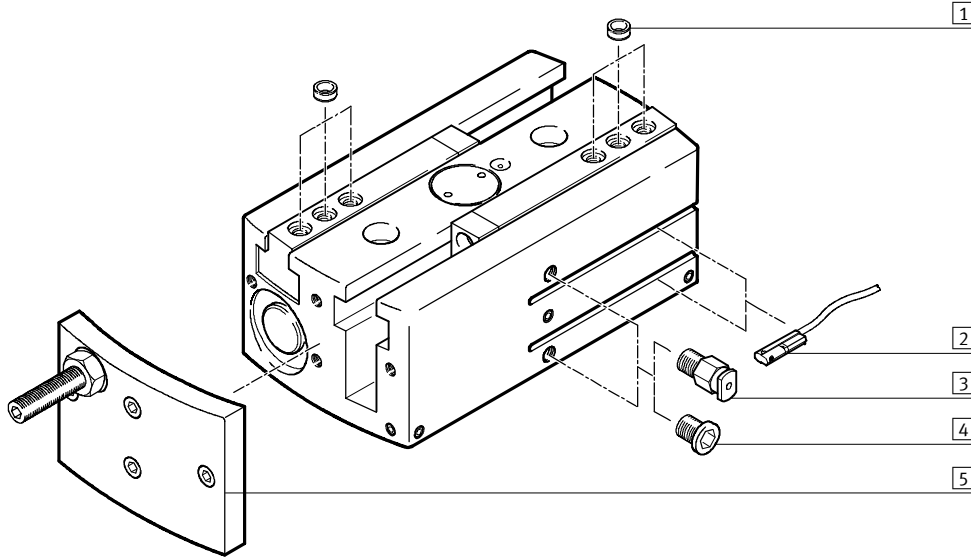

Accessories			
Type	Brief description	→ Page	
1	Centring sleeve ZBH	For centring when attaching gripper fingers	1 / 7.7-47
2	Proximity sensor SME-/SMT-10	For sensing the piston position	1 / 7.7-48
3	Push-in fitting QS	For connecting compressed air tubing with standard external diameters	Volume 3
4	Blanking plug B	For sealing compressed air connections when using air connections at the front	1 / 7.7-47
5	Stroke reducing plate HGPL-HR-...	For reducing the opening stroke	1 / 7.7-46
-	Unmachined gripper finger BUB-HGPL	Unmachined part specially matched to the gripper jaws for custom building of gripper fingers	1 / 7.7-47
-		Drive/gripper connections	Volume 5

Type codes



HGPL		-	14	-	40	-	A
Type							
HGPL	Long-stroke gripper						
Piston Ø							
Stroke [mm]							
Position sensing							
A	Via proximity sensor						

Long-stroke grippers HGPL

Technical data

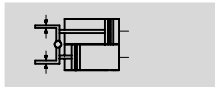
Function
Double-acting
HGPL-...A



-  - Piston \varnothing
14 ... 40 mm
-  - Stroke
80 ... 160 mm

General technical data							
Piston \varnothing	14		25		40		
Design	Synchronised pneumatic pistons Guided motion sequence						
Mode of operation	Double-acting						
Gripper function	Parallel						
Number of gripper jaws	2						
Max. applied load per external gripper finger ¹⁾ [N]	0.8		2.5		4.2		
Stroke per gripper jaw [mm]	40	80	40	80	40	80	
Pneumatic connection	M5						
Repetition accuracy ²⁾ [mm]	< 0.03						
Max. interchangeability [mm]	< 0.2						
Max. gripper jaw backlash ³⁾ [mm]	< 0.05						
Max. operating frequency [Hz]	< 1						
Rotational symmetry [mm]	< \varnothing 0.2						
Position sensing	Via proximity sensor						
Type of mounting	Via through-holes and centring sleeves With female thread and centring sleeves						
Fitting position	Any						

- 1) Valid for unthrottled operation.
- 2) End-position drift under constant conditions of use with 100 consecutive strokes in the direction of movement of the gripper jaws.
- 3) In the direction of the gripper jaw movement.

Operating and environmental conditions							
Piston \varnothing	14		25		40		
Operating pressure [bar]	3 ... 8						
Operating medium	Filtered compressed air, lubricated or unlubricated						
Ambient temperature ¹⁾ [°C]	+5 ... +60						
Corrosion resistance class CRC ²⁾	2						

- 1) Note operating range of proximity sensors.
- 2) Corrosion resistance class 2 according to Festo standard 940 070
Components requiring moderate corrosion resistance. Externally visible parts with primarily decorative surface requirements which are in direct contact with a normal industrial environment or media such as coolants or lubricating agents.

Weight [g]						
Piston \varnothing	14		25		40	
Stroke per gripper jaw	40 mm	440	1400	3300		
	80 mm	720	2200	4800		

Long-stroke grippers HGPL

Technical data

Materials

Sectional view

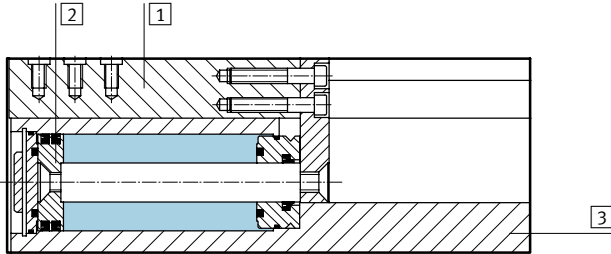

Gripper

1	Gripper jaw	Hardened steel, Citrox-coated
2	Piston	High-alloy steel
3	Housing	Wrought aluminium alloy with CompCote
-	Seals	Nitrile rubber, polyurethane
Note on materials		Free of copper, PTFE and silicone

Theoretical gripping force [N] at 6 bar per gripper jaw

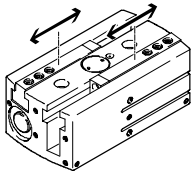

Piston Ø	14	25	40
Opening	75	247	633
Closing	92	295	754

Characteristic load values at the gripper jaws

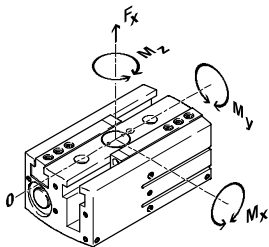

The indicated permissible forces and torques refer to a single gripper jaw. The indicated values include the lever arm, additional applied loads caused

by the workpiece or external gripper fingers, as well as forces which occur during movement. The zero coordinate line (gripper finger guide slot) must be

taken into consideration for the calculation of torques.

Piston Ø	14	25	40	
Max. permissible force F_z	[N]	500	1500	2500
Max. permissible torque M_x	[Nm]	35	100	125
Max. permissible torque M_y	[Nm]	35	60	80
Max. permissible torque M_z	[Nm]	35	70	100

Mass moment of inertia [$\text{kgm}^2 \times 10^{-4}$]

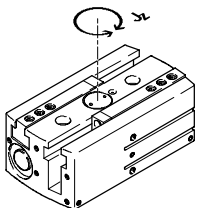

Mass moment of inertia [$\text{kgm}^2 \times 10^{-4}$] for long-stroke grippers in relation to the central axis with no load.

Piston Ø	14	25	40	
Stroke per gripper jaw	40 mm	4.69	18.88	66.83
	80 mm	21.93	78.7	198.87

Long-stroke grippers HGPL

Technical data

Opening and closing times [ms] at 6 bar

without external gripper fingers

with external gripper fingers

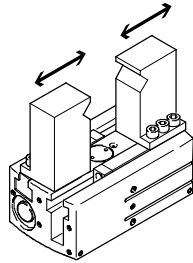
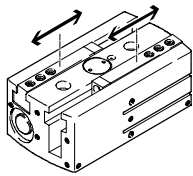

The indicated opening and closing times [ms] have been measured at room temperature and at 6 bar operating pressure with horizontally mounted additional gripper fingers.

The grippers must be throttled for greater applied loads. Opening and closing times must then be adjusted correspondingly.

Piston Ø	14		25		40	
without external gripper fingers – opening						
Stroke per gripper finger	40 mm	104	194	238		
	80 mm	234	360	414		
without external gripper fingers – closing						
Stroke per gripper finger	40 mm	86	192	205		
	80 mm	217	366	438		
with external gripper fingers as a function of applied load						
Stroke per gripper finger	40 mm					
Applied load	1 N	108	–	–		
	2 N	136	–	–		
	3 N	167	210	–		
	4 N	192	243	–		
	5 N	–	272	260		
	6 N	–	–	284		
	8 N	–	–	328		
with external gripper fingers as a function of applied load (80 mm stroke)						
Stroke per gripper finger	80 mm					
Applied load	1 N	243	–	–		
	2 N	343	–	–		
	3 N	420	401	–		
	4 N	485	463	–		
	5 N	–	518	478		
	6 N	–	–	524		
	8 N	–	–	604		

Long-stroke grippers HGPL

Technical data

Gripping force F_{Grip} per gripper jaw as a function of operating pressure and lever arm x

Gripping forces related to operating pressure and lever arm can be determined for the various sizes using the following graphs.

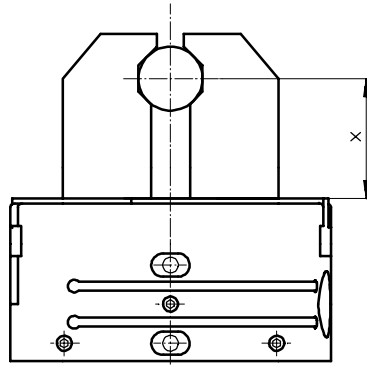

As external gripper: Closing operation

HGPL-14-40-A

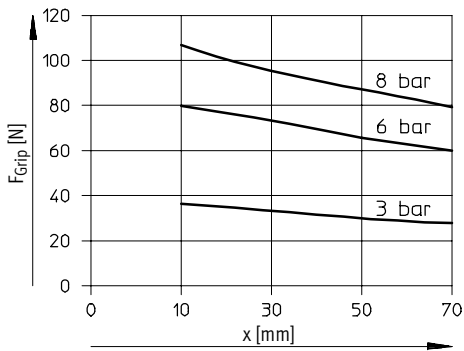

HGPL-14-80-A

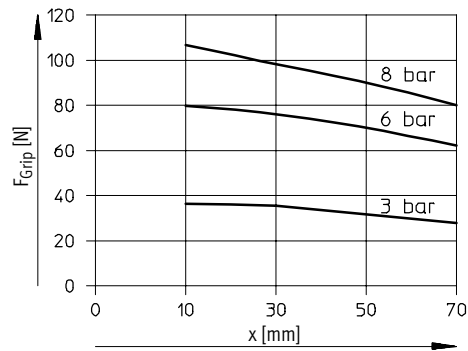

HGPL-25-40-A

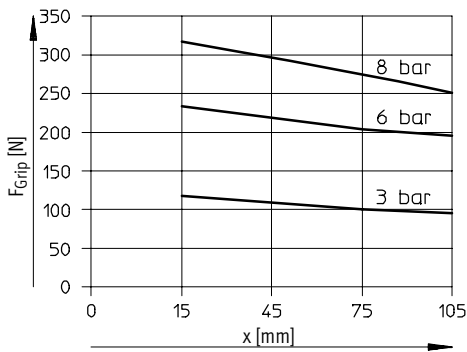

HGPL-25-80-A

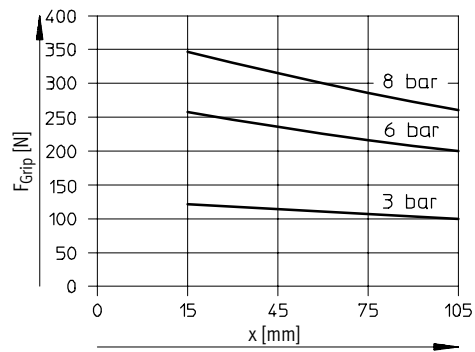

HGPL-40-40-A

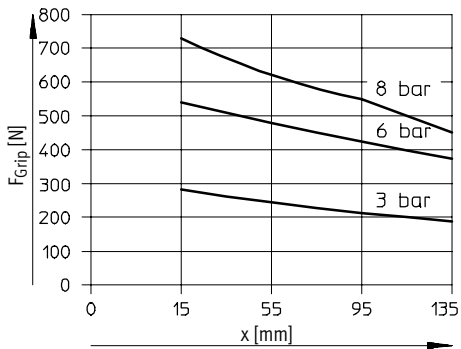

HGPL-40-80-A

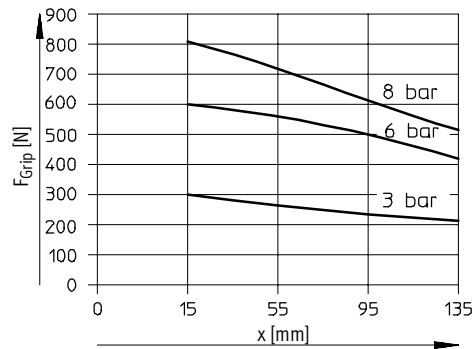

Long-stroke grippers HGPL

Technical data

Gripping force F_{Grip} per gripper jaw as a function of operating pressure and lever arm x
As internal gripper: Opening operation

HGPL-14-40-A

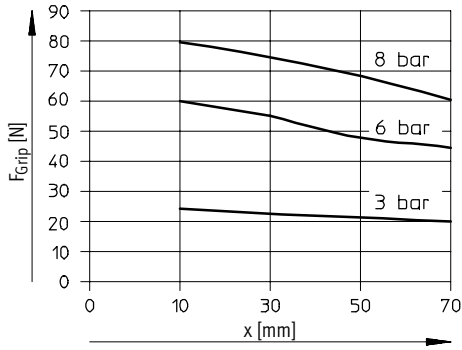

HGPL-14-80-A

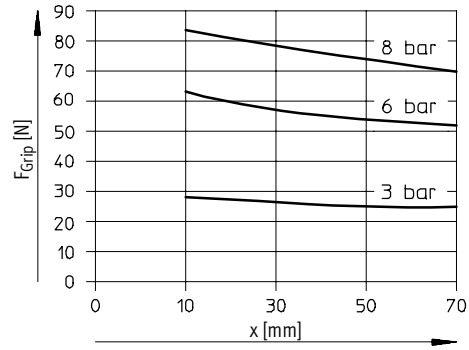

HGPL-25-40-A

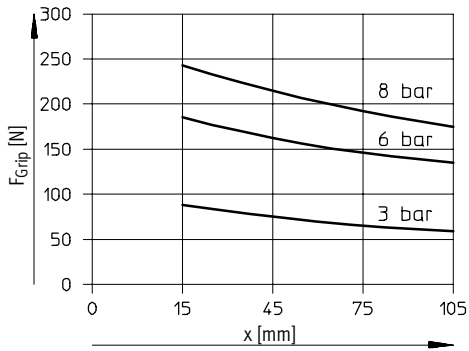

HGPL-25-80-A

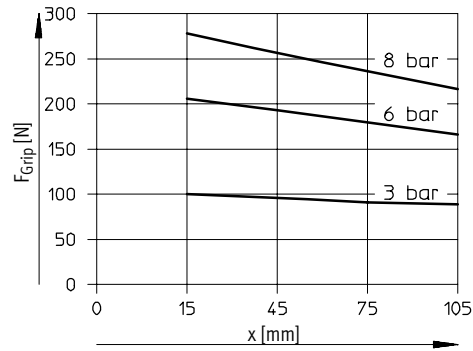

HGPL-40-40-A

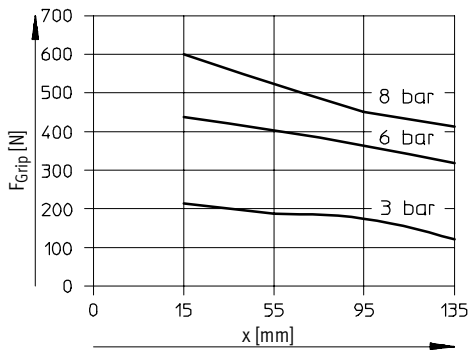

HGPL-40-80-A

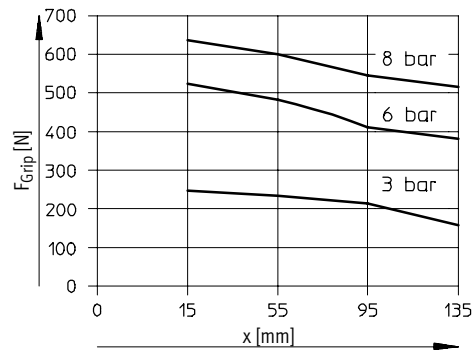

Long-stroke grippers HGPL

Technical data

Gripping force F_{Grip} per gripper jaw as a function of lever arm x and eccentricity y

Gripping forces at 6 bar dependent upon eccentric application of force and the maximum permissible off-centre point of force application can be determined for the various sizes using the following graphs.

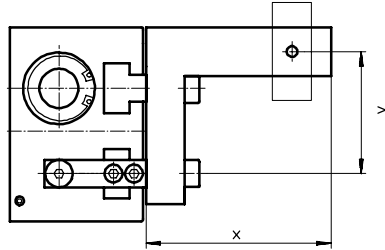

As external gripper: Closing operation

HGPL-14-40-A

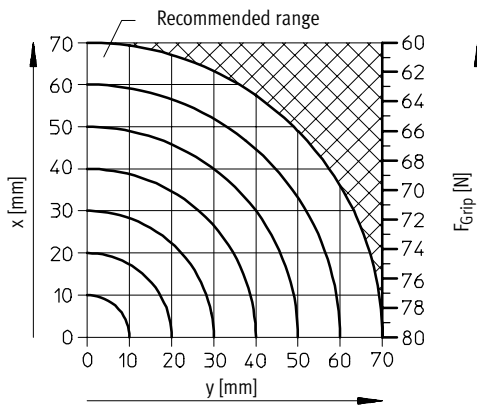

HGPL-14-80-A

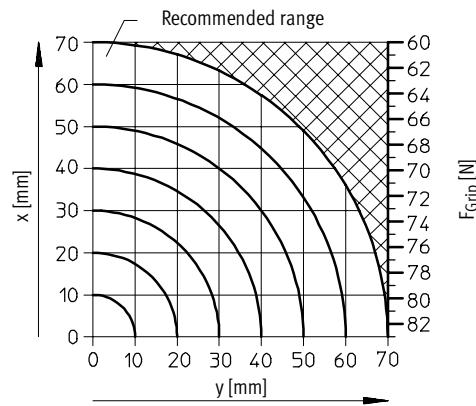

HGPL-25-40-A

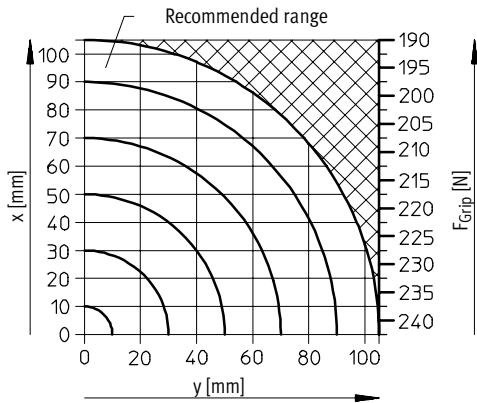

HGPL-25-80-A

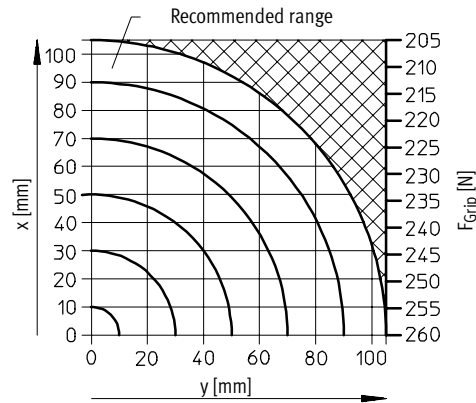

HGPL-40-40-A

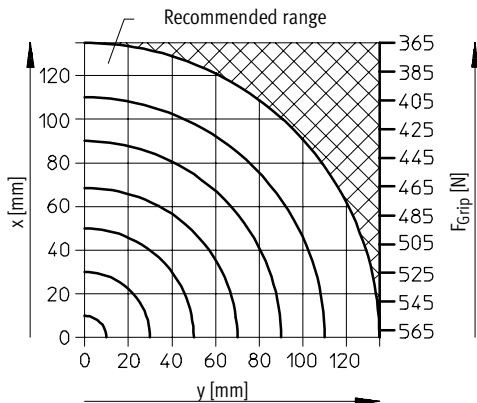

HGPL-40-80-A

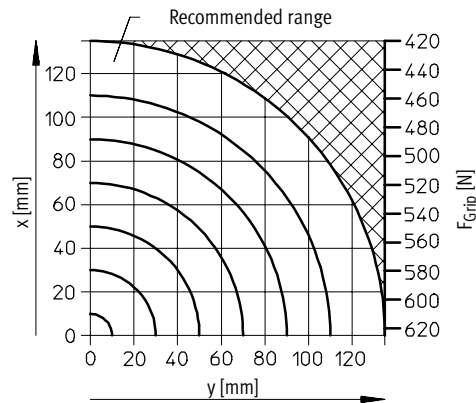

Long-stroke grippers HGPL

Technical data

Gripping force F_{Grip} per gripper jaw as a function of lever arm x and eccentricity y
As external gripper: Opening operation

HGPL-14-40-A

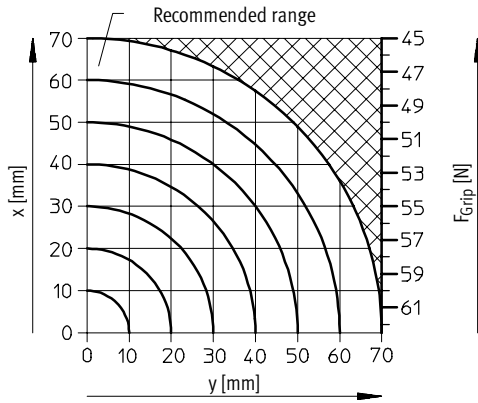

HGPL-14-80-A

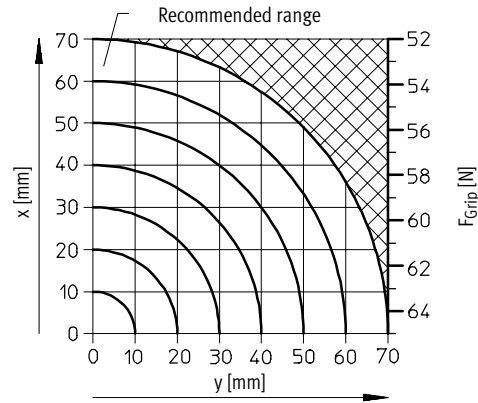

HGPL-25-40-A

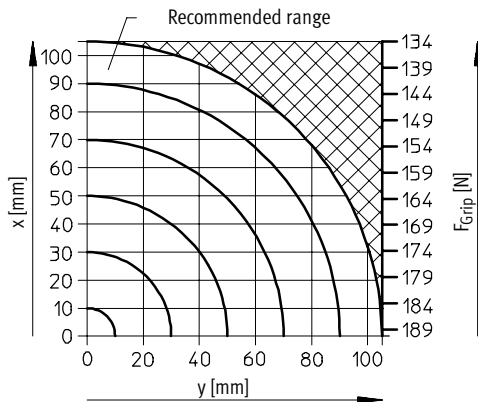

HGPL-25-80-A

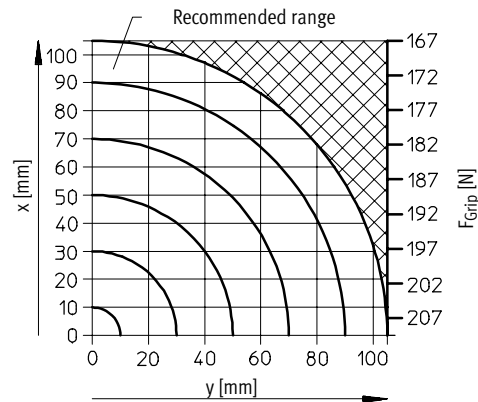

HGPL-40-40-A

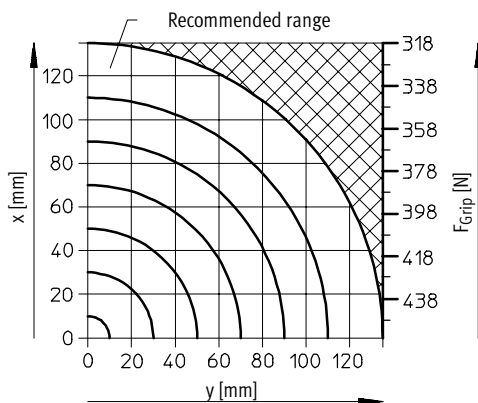

HGPL-40-80-A

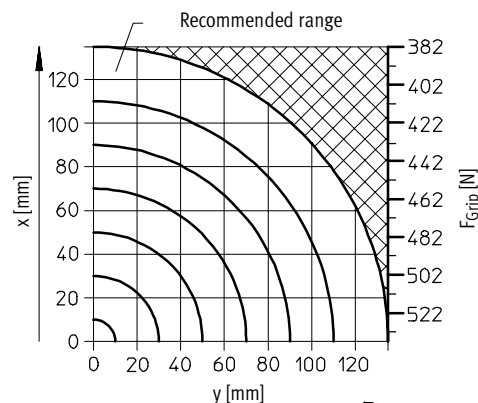

Long-stroke grippers HGPL

Technical data

Gripping force F_{Grip} per gripper jaw as a function of lever arm x and eccentricity y

Calculation example

Given:

Lever arm $x = 32$ mm

Eccentricity $y = 22$ mm

To be found:

Gripping force at 6 bar

Procedure:

- Determine the intersection xy between lever arm x and eccentricity y in the graph for HGPL-14-40-A
- Draw an arc (with centre at origin) through intersection xy
- Determine the intersection between the arc and the Y axis
- Read the gripping force

Result:

Gripping force = approx. 68.3 N

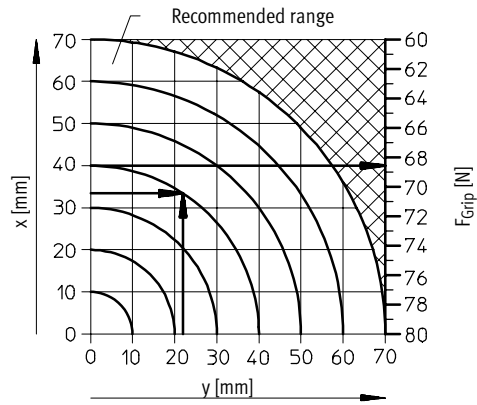

Long-stroke grippers HGPL

Technical data

Dimensions

Download CAD data → www.festo.com/en/engineering

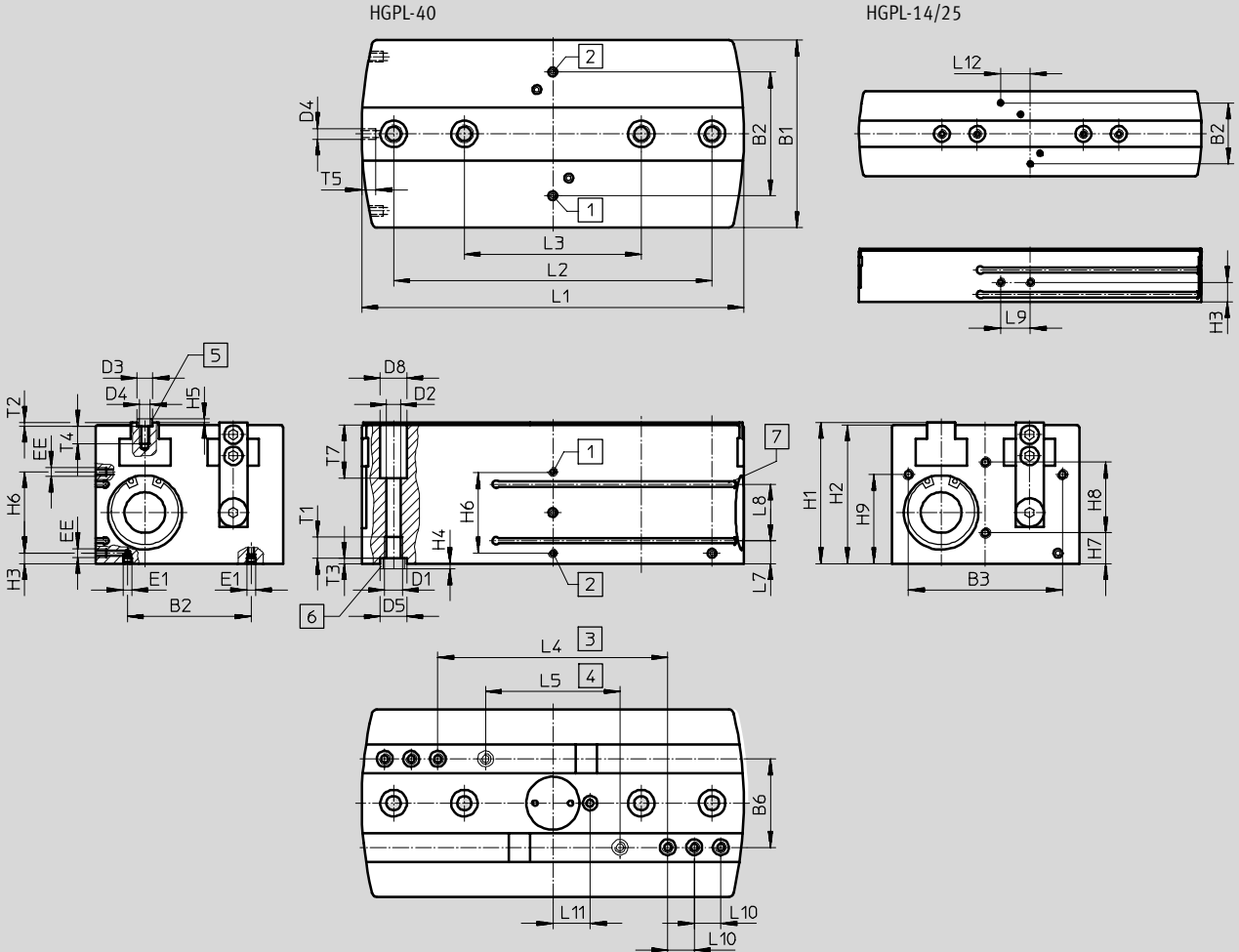

- 1 Compressed air connection opening, either on the side or bottom (bottom connection sealed on delivery)
- 2 Compressed air connection closing, either on the side or bottom (bottom connection sealed on delivery)
- 3 Gripper jaw open
- 4 Gripper jaw closed
- 5 Centring sleeves ZBH (4 included in scope of delivery)
- 6 Centring sleeves ZBH (2 included in scope of delivery)
- 7 Slot for proximity sensor SME-10/SMT-10

Long-stroke grippers HGPL

Technical data

Type	B1 ±0.05	B2 ±0.1	B3 ±0.1	B6 ±0.01	D1	D2 ∅ +0.1	D3 ∅ H8/h7	D4	D5 ∅ H8/h7	D8 ∅ H13	EE	E1
HGPL-14-40	48	34.5	37	22	M5	4.2	5	M3	9	7.4	M5	M3
HGPL-14-80												
HGPL-25-40	80	60	65	38	M6	5.1	7	M5	9	10	M5	M5
HGPL-25-80												
HGPL-40-40	106	70	87	50	M10	8.5	9	M6	15	15	M5	M5
HGPL-40-80												

Type	H1	H2 ±0.1	H3 ±0.1	H4 -0.3	H5 -0.3	H6 ±0.1	H7 ±0.1	H8 ±0.1	H9 ±0.1	L1 ±0.1	L2 ±0.02 ¹⁾ ±0.1 ²⁾	L3 ±0.02 ¹⁾ ±0.1 ²⁾	L4 ±0.5
HGPL-14-40	30	29	11	1.9	1.2	-	10	12	18	113.6	-	60	70
HGPL-14-80										193.6	100	60	150
HGPL-25-40	50	49	18	1.9	1.4	-	18	20	30	126	-	60	64
HGPL-25-80										206	100	60	144
HGPL-40-40	80	78.5	6	2.9	1.9	46	17.5	40	50.5	136	-	100	50
HGPL-40-80										216	100	180	130

Type	L5 ±0.5	L7 ±0.1	L8 ±0.1	L9 ±0.2	L10 ±0.02 ¹⁾ ±0.1 ²⁾	L11 ±0.5	L12 ±0.1	T1 min.	T2 +0.1	T3 +0.1	T4 min.	T5 min.	T7 +0.1
HGPL-14-40	30	4	14	16.8	8	9	16.8	12	1.3	2.1	5	6	10
HGPL-14-80	80												
HGPL-25-40	24	11	14	20	10	17.5	20	12	1.6	2.1	8	7	17
HGPL-25-80	64												
HGPL-40-40	10	13	32	-	15	21	-	15	2.1	3.1	10	8	30
HGPL-40-80	35												

1) For centring
2) For through-hole

Long-stroke grippers HGPL

Technical data and accessories

Ordering data			
Piston \varnothing	Stroke per gripper jaw	Double-acting without compression spring	
[mm]	[mm]	Part No.	Type
14			
	40	535 852	HGPL-14-40-A
	80	535 853	HGPL-14-80-A
25			
	40	535 854	HGPL-25-40-A
	80	535 855	HGPL-25-80-A
40			
	40	535 856	HGPL-40-40-A
	80	535 857	HGPL-40-80-A

Accessories

Stroke reducing plate HGPL-HR

Material:
Aluminium
Free of copper, PTFE and silicone

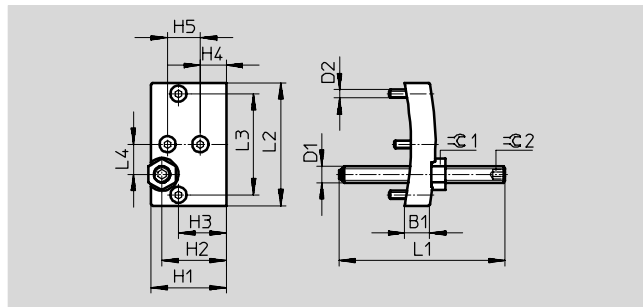

Dimensions and ordering data								
For \varnothing	B1	D1	D2	H1	H2	H3	H4	H5
[mm]	± 0.1			± 0.1	± 0.1	± 0.1	± 0.1	± 0.1
14	9	M6	M3	27.5	23.5	17.5	9.5	12
25	12	M8	M5	47.5	37.5	29.5	17.5	20
40	18	M12	M6	77	63	50	17	40

For \varnothing	L1	L2	L3	L4	$\varnothing C1$	$\varnothing C2$	Weight	Part No.	Type
[mm]	± 1	± 0.1	± 0.1	± 0.1			[g]		
14	61	45	37	11	10	3	45	539 092	HGPL-HR-14
25	61	77	65	19	13	4	150	539 093	HGPL-HR-25
40	61	103	87	25	19	6	455	539 094	HGPL-HR-40

Long-stroke grippers HGPL

Accessories

Accessories

Unmachined gripper finger

BUB-HGPL

(Scope of delivery: 2 pcs.)

Material:

Aluminium

Free of copper, PTFE and silicone

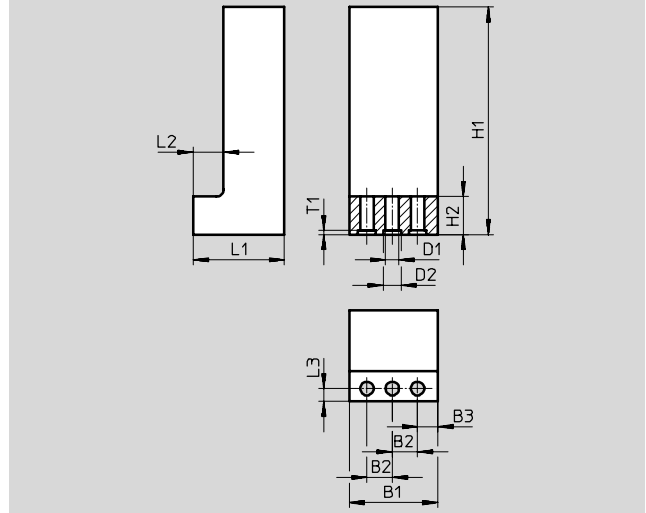

Dimensions and ordering data							
For \varnothing	B1	B2	B3	D1	D2	H1	H2
[mm]	± 0.1	+0.02		\varnothing +0.1	\varnothing H8	\varnothing ± 0.1	
14	25	8	4	3.2	5	80	11
25	35	10	8	5.3	7	120	15
40	50	15	10	6.4	9	150	18

For \varnothing	L1	L2	L3	T1	Weight per unmachined gripper finger [g]	Part No.	Type
[mm]	± 0.1	+0.1	+0.1	+0.1			
14	20.5	8	3.3	1.3	75	537 316	BUB-HGPL-14
25	36	12	5	1.6	295	537 317	BUB-HGPL-25
40	49.5	16.5	8	2.1	720	537 318	BUB-HGPL-40

Ordering data		Technical data \rightarrow 1 / 10.1-3			
	For piston \varnothing [mm]	Weight [g]	Part No.	Type	PU ¹⁾
Centring sleeve for the gripper jaws					
	14	1	189 652	ZBH-5	10
	25	1	186 717	ZBH-7	10
	40	1	150 927	ZBH-9	10
Centring sleeve for the gripper					
	14	1	189 652	ZBH-9	10
	25				
	40	3	191 409	ZBH-15	10
Blanking plug					
	14 (at front)	0.6	30 979	B-M3-S9	10
	14, 25, 40	1	174 308	B-M5-B	10





1) Packaging unit quantity





Core Range







Long-stroke grippers HGPL

Accessories

FESTO

Ordering data – Proximity sensors for slot type 10, magneto-resistive								Technical data → 1 / 10.2-47	
	Assembly	Switch output	Electrical connection		Cable length [m]	Connection direction	Part No.	Type	
			Cable	Plug M8					
NO contact									
	Insertable from above	PNP	3-core	–	2.5	In-line	525 915	SMT-10F-PS-24V-K2,5L-OE	
			–	3-pin	0.3	In-line	525 916	SMT-10F-PS-24V-K0,3L-M8D	
			–	3-pin	0.3	Lateral	526 675	SMT-10F-PS-24V-K0,3Q-M8D	
	Insertable from end	PNP	–	3-pin	0.3	In-line	173 220	SMT-10-PS-SL-LED-24	
			3-core	–	2.5		173 218	SMT-10-PS-KL-LED-24	

Ordering data – Proximity sensors for slot type 10, magnetic reed								Technical data → 1 / 10.2-50	
	Assembly	Electrical connection		Cable length [m]	Connection direction	Part No.	Type		
		Cable	Plug M8						
NO contact									
	Insertable from above	–	3-pin	0.3	In-line	525 914	SME-10F-DS-24V-K0,3L-M8D		
		3-core	–	2.5	In-line	525 913	SME-10F-DS-24V-K2,5L-OE		
		2-core	–	–	–	526 672	SME-10F-ZS-24V-K2,5L-OE		
	Insertable from end	–	3-pin	0.3	In-line	173 212	SME-10-SL-LED-24		
		3-core	–	2.5		173 210	SME-10-KL-LED-24		

Ordering data – Plug sockets							Technical data → 1 / 10.2-100		
	Assembly	Switch output		Connection	Cable length [m]	Part No.	Type		
		PNP	NPN						
Straight socket									
	Union nut M8			3-pin	2.5	159 420	SIM-M8-3GD-2,5-PU		
					5	159 421	SIM-M8-3GD-5-PU		
Angled socket									
	Union nut M8			3-pin	2.5	159 422	SIM-M8-3WD-2,5-PU		
					5	159 423	SIM-M8-3WD-5-PU		

Handling units
T-slot grippers

7.7

 Core Range