

Swivel/gripper units HGDS

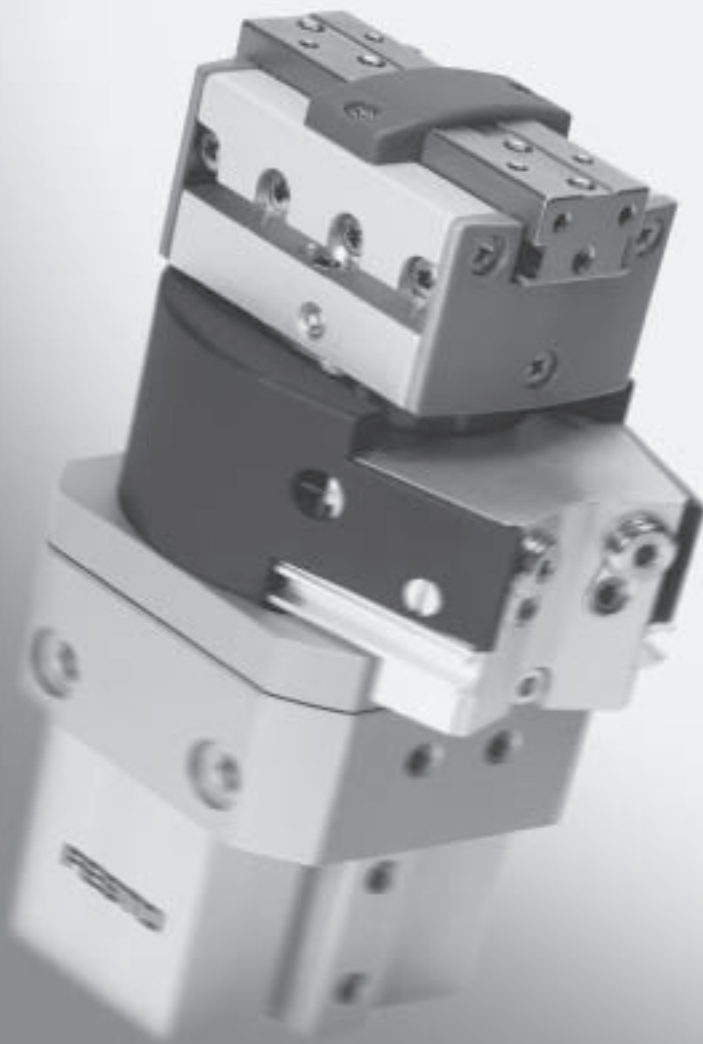

- Swivelling and gripping in one unit
- Cushioning concepts:
Elastomer cushioning or hydraulic cushioning
- Quick, precise and light

Swivel/gripper units HGDS

Key features

At a glance

Combination of precision parallel gripper and swivel module

The power transmission from the linear motion to the gripper motion takes place via the piston rod, which opens and closes the gripper jaws housed in the gripper housing via 2 reversing levers.

The swivel motion takes place via a swivel drive. It can be adjusted almost infinitely via 2 stops (max. 210°). The rotary motion is cushioned either via a flexible cushioning buffer or a hydraulic shock absorber. The swivel angle can be finely adjusted by means of a precision adjustment facility.

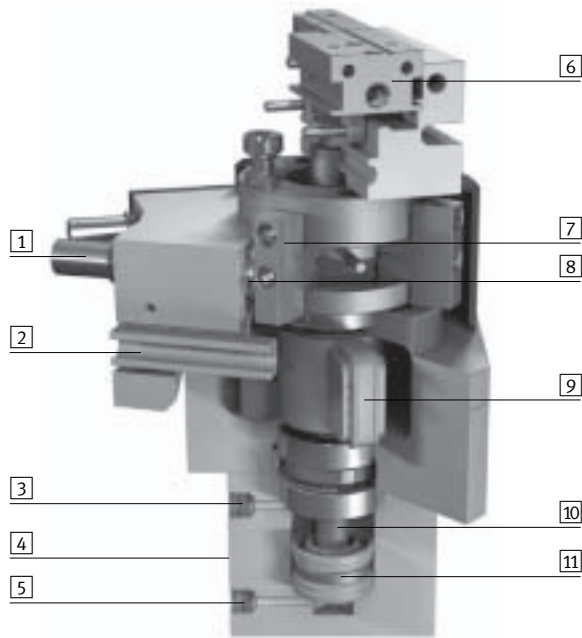

- 1 Flexible cushioning or hydraulic shock absorbers
- 2 Slot for proximity sensor SME-/SMT-10 for sensing the swivel position
- 3 Gripper compressed air connection, closing
- 4 Slot for proximity sensor SME-/SMT-10 for sensing the gripper position
- 5 Gripper compressed air connection, opening
- 6 Gripper jaw
- 7 Adjustable stop plates for the swivel motion, with magnet
- 8 Precise end stop with flexible cushioning or integrated shock absorber
- 9 Rotary vane
- 10 Piston rod for gripping motion
- 11 Piston with magnet

Mounting options

Direct mounting

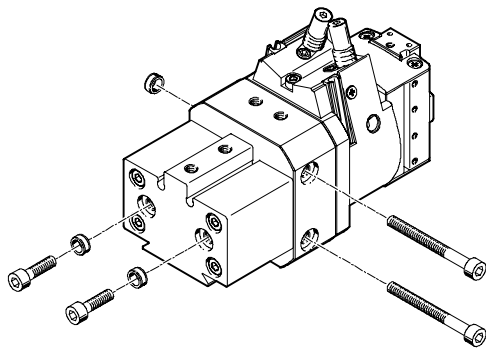

Dovetail connection

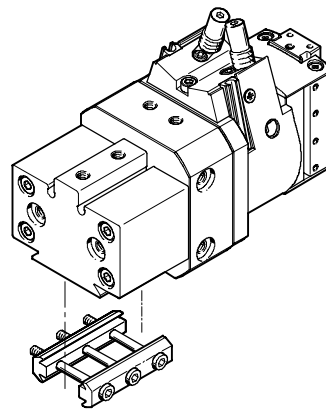

Note
Swivel/gripper units are not suitable for the following or similar applications:

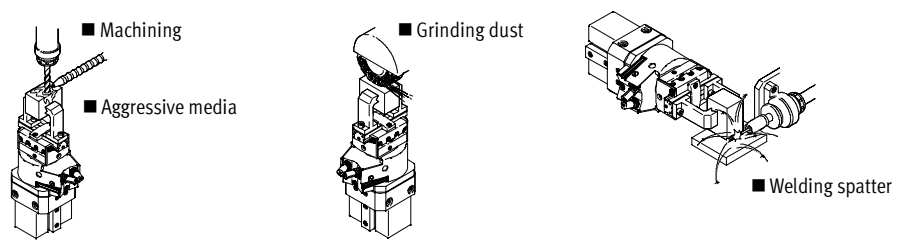

Swivel/gripper units HGDS

Peripherals overview and type codes

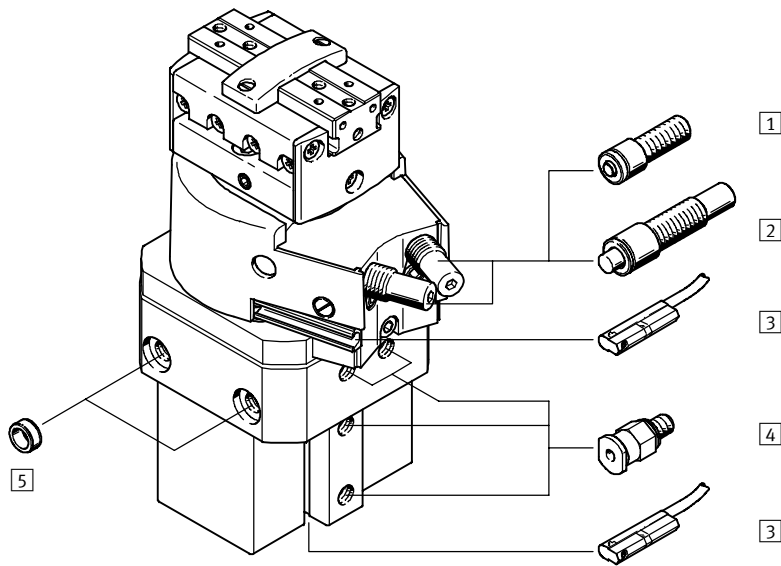

Accessories			
Type	Brief description	→ Page	
1	Cushioning P	Non-adjustable, flexible cushioning. Is used for smaller loads	-
2	Cushioning YSRT	Self-adjusting, hydraulic shock absorber	-
3	Proximity sensor SME-/SMT-10	For sensing the gripper and rotary vane position	1 / 7.8-12
4	Push-in fitting QS	For connecting compressed air tubing with standard external diameters	Volume 3
5	Centring sleeve ZBH	For centring the gripper when mounting (2 included in scope of delivery)	1 / 7.8-12
-		Drive/gripper connections	Volume 5

		HGDS	-	16	-	YSRT	-	A
Type								
HGDS	Swivel/gripper unit							
Size								
Cushioning								
P	Flexible cushioning							
YSRT	Hydraulic cushioning							
Position sensing								
A	Via proximity sensor							

Swivel/gripper units HGDS

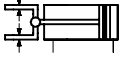

Technical data

Function
Gripping



Swivelling



-  - Size
12, 16, 20
-  - Stroke
5, 9, 14 mm



General technical data				
Size	12		16	20
Design	Semi-rotary drive Parallel gripper with drive			
Mode of operation	Double-acting			
Pneumatic connection	M5			
Type of mounting	With threaded hole and centring hole Via through-holes Clamped in dovetail slot			
Fitting position	Any			
Theoretical gripping force at 6 bar	Opening [N]	60	114	180
	Closing [N]	53.4	82.8	142.8
Relubrication intervals of guide	10 million switching cycles			
Product weight [g]	465	660	1120	

Operating and environmental conditions				
Size	12		16	20
Operating pressure [bar]	3 ... 8			
Operating medium	Filtered compressed air, lubricated or unlubricated			
Ambient temperature ¹⁾ [°C]	+5 ... +60			
Corrosion resistance class CRC ²⁾	2			

- 1) Note operating range of proximity sensors.
 2) Corrosion resistance class 2 according to Festo standard 940 070
 Components requiring moderate corrosion resistance. Externally visible parts with primarily decorative surface requirements which are in direct contact with a normal industrial environment or media such as coolants or lubricating agents.

Materials

Sectional view

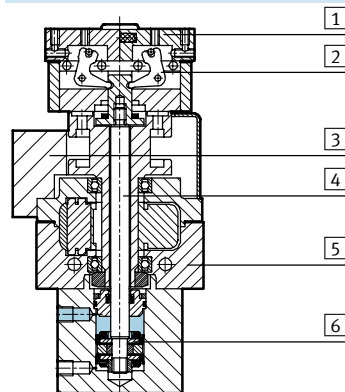

Gripper		
1	Gripper jaw	Wrought aluminium alloy, nickel-plated
2	Lever	Hardened steel
3	Stop	Wrought aluminium alloy, hard-anodised
4	Piston rod	Stainless steel
5	Housing	Wrought aluminium alloy, hard-anodised
6	Piston	Nitrile rubber, polyurethane
-	Rubber buffer	Nitrile rubber

Swivel/gripper units HGDS

Technical data

Technical data – Swivelling

Size	12	16	20
Swivel angle	[°] 0 ... 210 → 1 / 7.8-10		
Theoretical torque ¹⁾	[Nm] 0.85	1.25	2.5
Repetition accuracy ¹⁾	P cushioning	[°] < 0.2	
	YSRT cushioning	[°] < 0.02	
Cushioning	→ 1 / 7.8-6		
Max. swivelling frequency ¹⁾	P cushioning	[Hz] 2	
	YSRT cushioning	[Hz] -	
Position sensing	Via proximity sensor		

1) At 6 bar

Mass moments of inertia J at 6 bar as a function of swivel time t and swivel angle

HGDS-PP-12-P-A

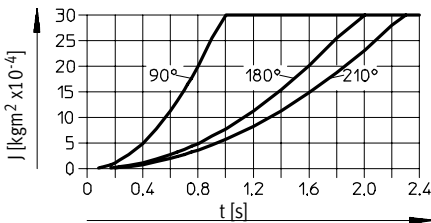

HGDS-PP-16-P-A

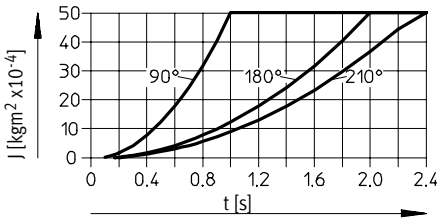

HGDS-PP-16-YSRT-A

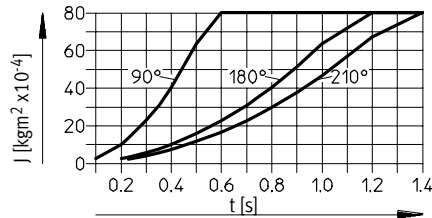

HGDS-PP-20-P-A

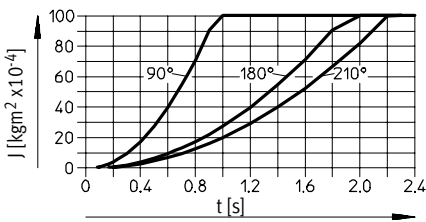

HGDS-PP-20-YSRT-A

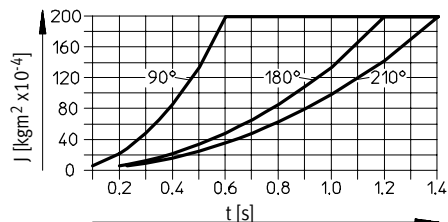

Dependency between operating pressure and swivel time

When the operating pressure of the gripper drive is reduced, the permissible swivel time at the same mass moment of inertia must be increased by 15% per bar of operating pressure.

Example:

Given:

$$J = 40 \text{ kgm}^2 \times 10^{-4}$$

Operating pressure 4 bar (gripper drive)

Swivel time at 6 bar = 0.4 s, see graph opposite

This yields a swivel time at 4 bar:

$$t = 0.4 + 2 \times 15\% = 0.52 \text{ s}$$

Cushioning time of the shock absorber

$$= 0.1 \text{ s}$$

This yields a swivel time of

$$t_{\text{tot.}} = 0.52 \text{ s} + 0.1 \text{ s} = 0.62 \text{ s}$$

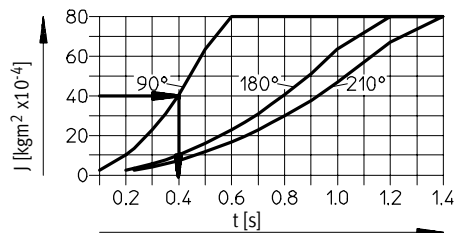

Swivel/gripper units HGDS

Technical data

Precision adjustment of the swivel angle

The swivel angle can be adjusted roughly by means of two stop plates → 1 / 7.8-2. The precision adjustment works as follows:
Variants P and YSRT differ in only one component. The retainer and the fine

adjustment are identical. In both variants, the rotary vane travels to a metallic stop, which can be adjusted with great accuracy via the adjustable sleeve for P cushioning or the shock absorber for YSRT cushioning.

1) Loosen the locking screw underneath the cushioning element

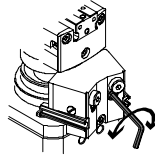

2) Adjust the cushioning element as required. Observe the minimum and maximum settings.

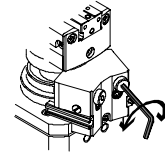

Size			12	16	20
Precision adjustment range	P cushioning	[°]	-6		
	YSRT cushioning	[°]	-2.5		
Swivel angle adjuster per revolution		[°]	3.1	2.8	2.2

Min. setting range, to the inner stop

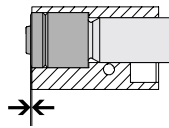

Max. setting range, to the notch

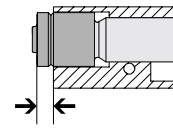

Swivel/gripper units HGDS

Technical data

Technical data – Gripping

Size	12	16	20
Gripper function	Parallel		
Number of gripper fingers	2		
Max. applied load per external gripper finger ¹⁾ [N]	0.3	0.5	1.0
Stroke per gripper jaw [mm]	2.5	4.5	7
Max. gripper jaw backlash [mm]	0		
Max. gripper jaw angular backlash [°]	0		
Repetition accuracy [mm]	< 0.02		
Max. operating frequency [Hz]	4		
Position sensing	Via proximity sensor		

1) Valid for unthrottled operation.

Gripping force F_{Grip} per gripper jaw as a function of operating pressure p

Gripping forces related to operating pressure and lever arm can be determined for the various sizes using the following graphs.

The characteristic curves apply for external and internal gripping.

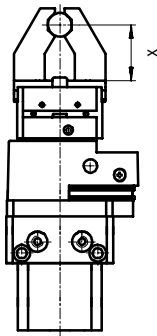

 Note

The gripping force is practically independent of the lever arm. Fluctuation at max. lever arm and max. operating pressure approx. 10%.

for unthrottled operation:

HGDS-12 (max. lever arm x 40 mm)

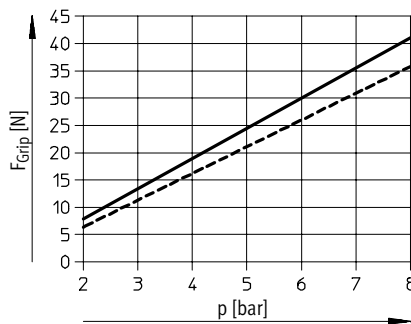

HGDS-16 (max. lever arm x 50 mm)

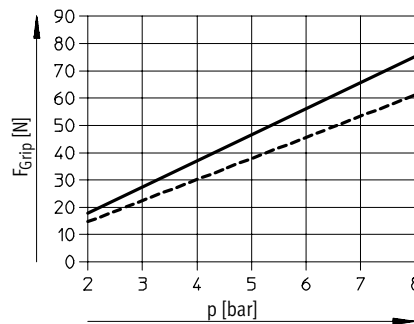

HGDS-20 (max. lever arm x 70 mm)

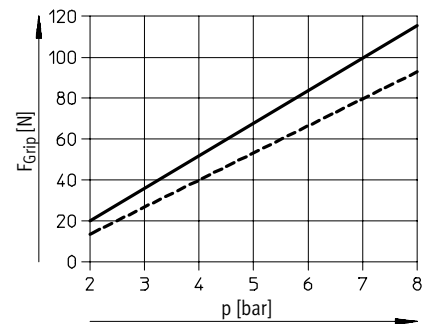

— Opening
- - - Closing

Swivel/gripper units HGDS

Technical data

Opening and closing times [ms] at 6 bar

With gripper jaws

With additional gripper fingers

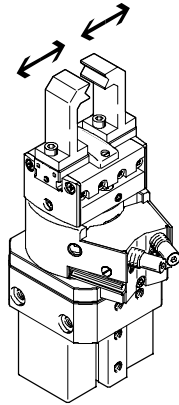
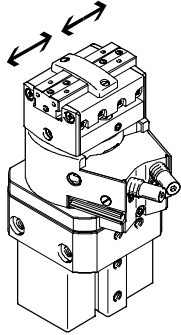

The indicated opening and closing times [ms] have been measured at room temperature and at 6 bar operating pressure with horizontally mounted gripper without external

gripper fingers. The grippers must be throttled for greater applied loads. Opening and closing times must then be adjusted correspondingly.

with additional gripper fingers as a function of applied load

Size	12	16	20	
Max. applied load	0.3 N	0.5 N	1.0 N	
HGDS-...-A unthrottled	Opening	20	50	70
	Closing	30	50	100

with additional gripper fingers as a function of applied load

Size	12		16		20			
	1.0 N	2.0 N	1.0 N	2.0 N	1.0 N	2.0 N		
HGDS-...-A throttled	Closing		100	150	100	200	100	250

Eccentricity y as a function of lever arm x

The dependency on the lever arm and the maximum permissible off-centre point of force application can be determined for the various sizes using the following graphs.

The gripping forces apply, see above.

It is vital that you adhere to the mass moment of inertia $\rightarrow 1 / 7.8-5$ when making your selection.

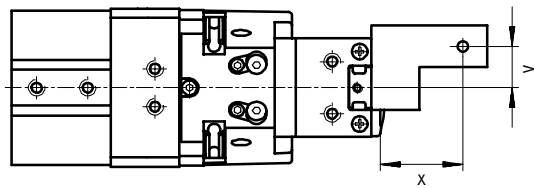

for unthrottled operation:

HGDS-12 (max. lever arm 40 mm)

HGDS-16 (max. lever arm 50 mm)

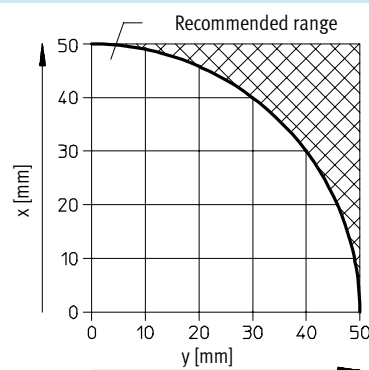
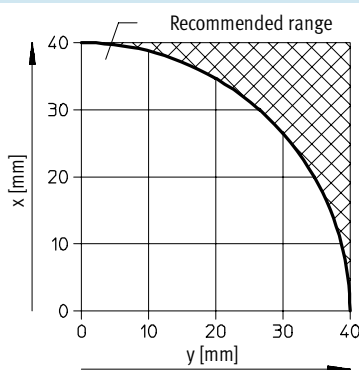

Swivel/gripper units HGDS

Technical data

Eccentricity y as a function of lever arm x

HGDS-20 (max. lever arm 70 mm)

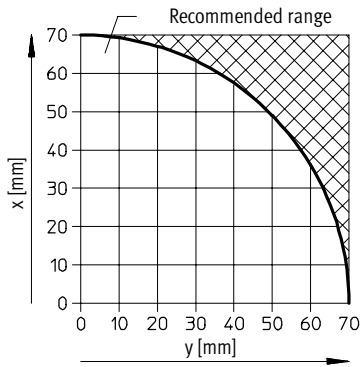

Calculation example

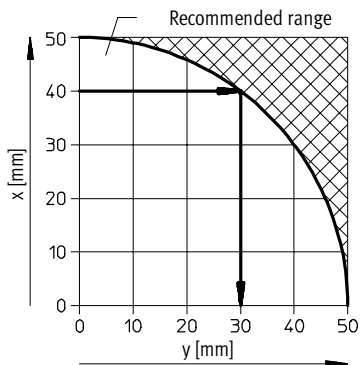

Lever arm $x = 40$ mm

To be found: Eccentricity y

■ Move along the horizontal axis to the point of intersection

■ Then move vertically downwards until you intersect the scale

■ Read the eccentricity

Max. eccentricity = 30 mm

Characteristic load values per gripper jaw

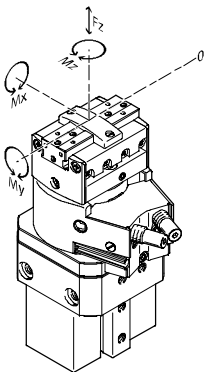

The indicated permissible forces and torques refer to a single gripper jaw. The indicated values include the lever arm, additional applied loads caused by the workpiece or external gripper fingers, as well as forces which occur during movement.

The zero coordinate line (gripper finger guide) must be taken into consideration for the calculation of torques.

Size		12	16	20
Max. permissible force F_z	[N]	20	30	60
Max. permissible torque M_x	[Nm]	1.5	4	8
Max. permissible torque M_y	[Nm]	1.5	4	8
Max. permissible torque M_z	[Nm]	1.5	4	8

Swivel/gripper units HGDS

Technical data

Dimensions

Download CAD data → www.festo.com/en/engineering

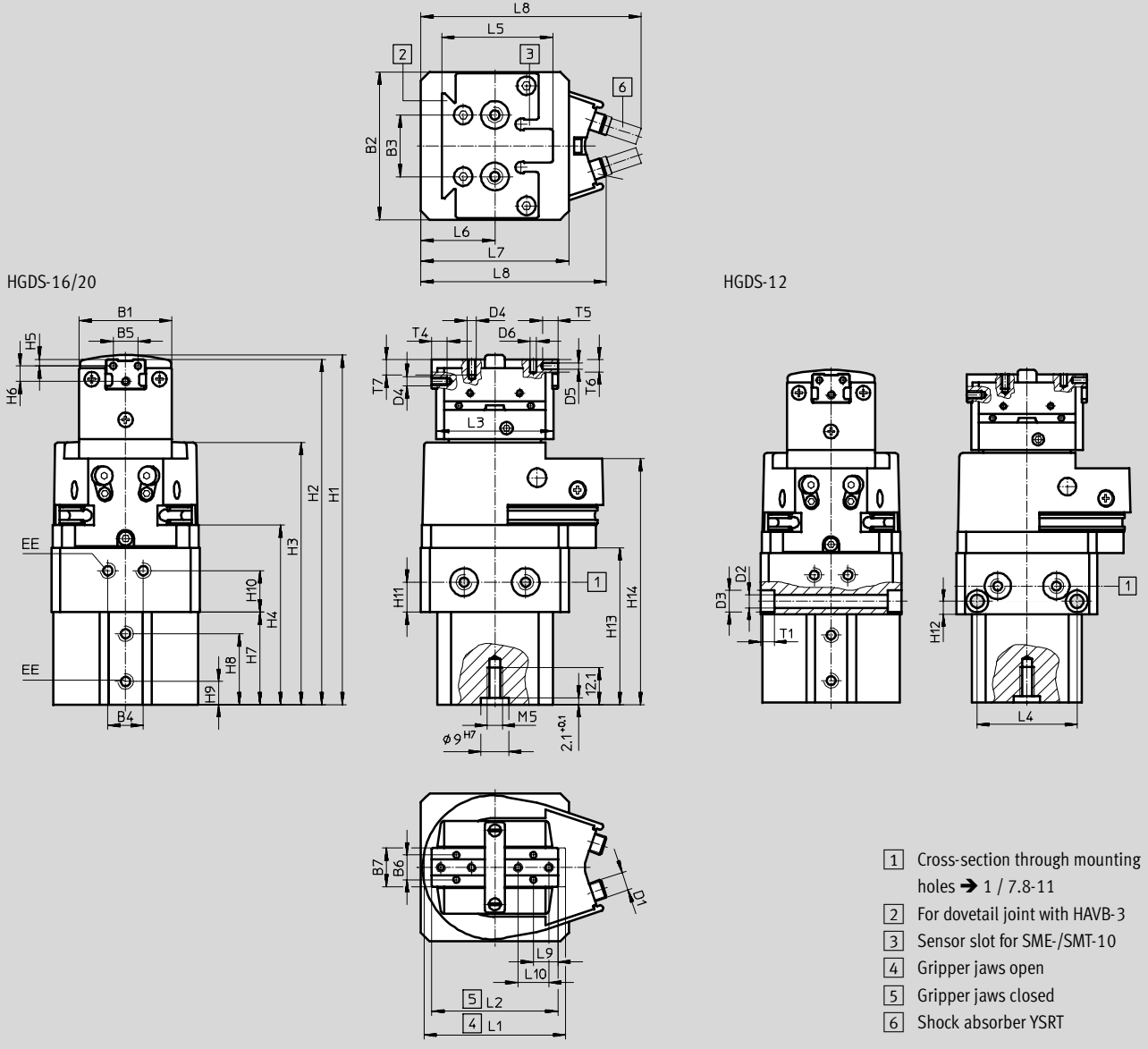

Swivel angle

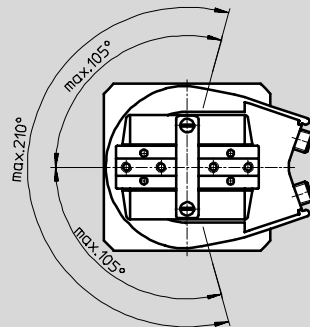

Swivel/gripper units HGDS

Technical data

Cross-section at 1 → 1 / 7.8-10

HGDS-12

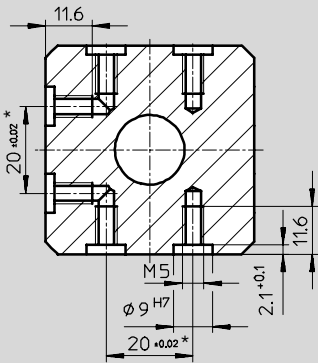

HGDS-16

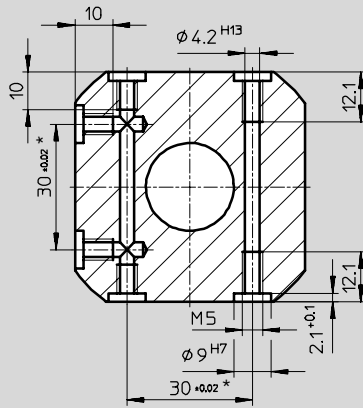

HGDS-20

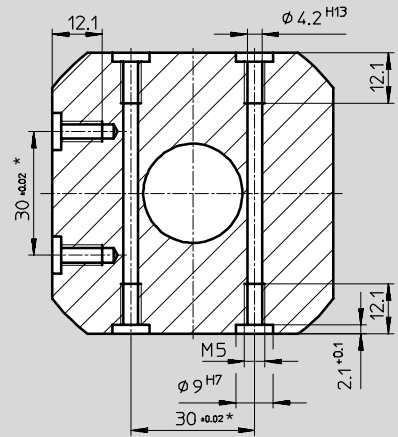

Size	B1	B2 ±0.03	B3 ±0.02*	B4	B5 ±0.02	B6 ±0.02	B7 ±0.1	D1	D2 Ø H13	D3 Ø H13	D4	D5 Ø H8
12	30	48	20	11.5	8	8	12.5	M6x0.5	4.5	7.5	M3	2
16	34	55	30	13	10	10	16	M8x1	-	-	M3	2
20	40	68	30	16	12	12	20	M10x1	-	-	M4	2.5

Size	D6 Ø H8	EE	H1 +1/-0.6	H2 +0.8/-0.4	H3 +1.3/-0.2	H4 +0.8/-0.2	H5 ±0.02	H6 ±0.12	H7 ±0.1	H8 ±0.1	H9
12	2	M5	113.4	111.9	85.1	58.2	2	5	30	23	7.5
16	2	M5	121.7	120.1	92.1	64.3	3	5	34.5	26	8.3
20	2.5	M5	154.8	152.8	112.3	81.7	3	7	43	34.6	8.3

Size	H10	H11 -0.1	H12	H13 +1/-0.2	H14 +1/-0.2	L1 ±0.5	L2 ±0.5	L3 ±0.5	L4 ±0.1	L5	L6 ±0.05
12	13.5	9.7	4.5	51.3	79.8	46	41	38	34	36	24
16	14	8	-	58.2	86.7	58	49	47	-	40.5	27.5
20	19	9	-	73.1	105.6	78	64	61	-	40.5	34

Size	L7 ±0.03	L8 ±1		L9 ±0.02	L10	T1	T4 min.	T5	T6	T7 min.
		P	YSRT							
12	48	59.5	-	8	10	4.6	5	5	4	5
16	55	68.5	80.5	8	10	-	6.5	6	5	5
20	68	85.4	96.4	12	14	-	10	8	7	7

* Tolerance valid for centring hole Ø 9H7

Swivel/gripper units HGDS



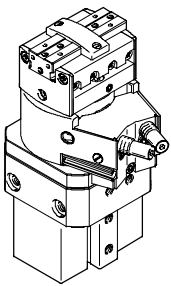



Technical data and accessories

Ordering data				
	Size	With flexible P cushioning		With hydraulic YSRT cushioning
	[mm]	Part No.	Type	Shock absorber Part No. Type
	12	534 278	HGDS-PP-12-P-A ¹⁾	–
	16	534 280	HGDS-PP-16-P-A ¹⁾	534 281 HGDS-PP-16-YSRT-A ¹⁾
	20	534 282	HGDS-PP-20-P-A ¹⁾	534 283 HGDS-PP-20-YSRT-A ¹⁾

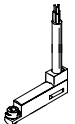
1) Two centring sleeves are included in the scope of delivery.

Ordering data – Centring sleeve					Technical data → 1 / 10.1-3	
	For size	Weight	Part No.	Type	PU ¹⁾	
	[mm]					
Centring sleeve						
	12, 16, 20	1	150 927	ZBH-9	10	

1) Packaging unit quantity

Ordering data – Proximity sensors, connecting cable at right angles						Technical data → 1 / 10.2-47		
	Electrical connection		Cable length	Part No.	Type			
	Cable	Plug M8						[m]
	NO contact, magneto-resistive							
	3-core	–	2.5	526 674	SMT-10F-PS-24V-K2,5Q-OE			
	2-core	–	2.5	526 676	SMT-10F-ZS-24V-K2,5Q-OE			
	–	3-pin	0.3	526 675	SMT-10F-PS-24V-K0,3Q-M8D			
	NO contact, magnetic reed							
	3-core	–	2.5	526 670	SME-10F-DS-24V-K2,5Q-OE			
2-core	–	2.5	526 673	SME-10F-ZS-24V-K2,5Q-OE				
–	3-pin	0.3	526 671	SME-10F-DS-24V-K0,3Q-M8D				

 Core Range







Swivel/gripper units HGDS

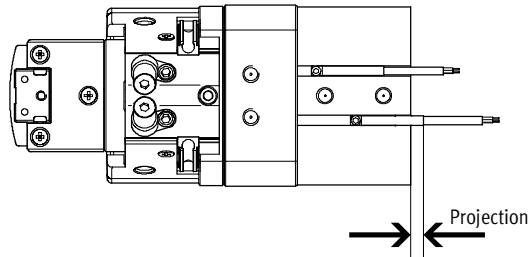

Accessories

If the swivel/gripper unit is mounted **on the front**, proximity sensors with the connecting cable **at right angles** should be used.

When proximity sensors with in-line connecting cables are used, the sensors project beyond the swivel/gripper unit after the switching point has been set.



Ordering data – Proximity sensors, in-line connecting cable							Technical data → 1 / 10.2-50	
Cable	Electrical connection		Cable length [m]	Projection at HGDS in [mm]			Part No.	Type
	Plug M8			∅ 12	∅ 16	∅ 20		
	NO contact, magneto-resistive							
	3-core	–	2.5	8.3	7.1	4.4	525 915	SMT-10F-PS-24V-K2,5L-OE 
	2-core	–	–	–	–	–	526 677	SMT-10F-ZS-24V-K2,5L-OE 
	–	3-pin	0.3	–	–	–	525 916	SMT-10F-PS-24V-K0,3L-M8D 
	NO contact, magnetic reed							
	3-core	–	2.5	2.7	2.1	–	525 913	SME-10F-DS-24V-K2,5L-OE 
2-core	–	–	–	–	–	526 672	SME-10F-ZS-24V-K2,5L-OE 	
–	3-pin	0.3	–	–	–	525 914	SME-10F-DS-24V-K0,3L-M8D 	

Ordering data – Plug sockets						Technical data → 1 / 10.2-100	
Assembly	Switch output		Connection	Cable length [m]	Part No.	Type	
	PNP	NPN					
Straight socket							
	Union nut M8	<input type="checkbox"/>	<input type="checkbox"/>	3-pin	2.5	159 420	SIM-M8-3GD-2,5-PU
		<input type="checkbox"/>	<input type="checkbox"/>		5	159 421	SIM-M8-3GD-5-PU
Angled socket							
	Union nut M8	<input type="checkbox"/>	<input type="checkbox"/>	3-pin	2.5	159 422	SIM-M8-3WD-2,5-PU
		<input type="checkbox"/>	<input type="checkbox"/>		5	159 423	SIM-M8-3WD-5-PU

 Core Range

