

Cover caps

Technical data – Isolating discs

Isolating discs are used to seal air ducts within a valve terminal. This enables different pressure zones to be created, for example.

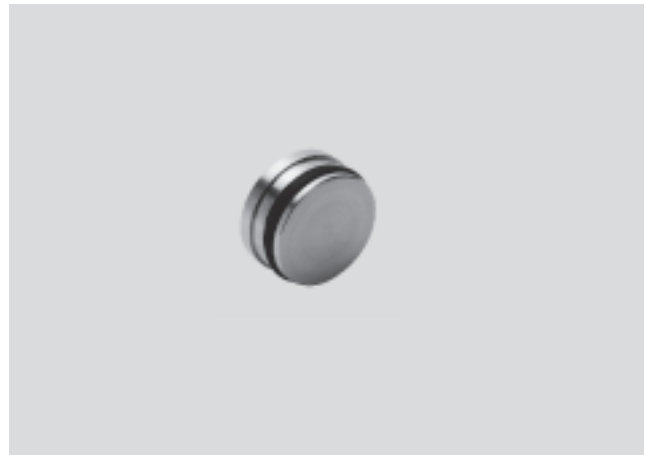

Ordering data							
View	Product weight [g]	Material	Thickness [mm]	O.D. [mm]	Nominal size [inch]	Part No.	Type
	–	Wrought aluminium alloy	6.6	30	1/2	119 743	NSC-1/2-03-7,0
	3.6	Wrought aluminium alloy	1.4	19.65	1/2	161 105	NSC-1/2-01-VDMA
	2	Wrought aluminium alloy	1.4	16.65	3/8	161 113	NSC-3/8-01-VDMA

Example illustrating the fitting of isolating discs

NSC-...-VDMA

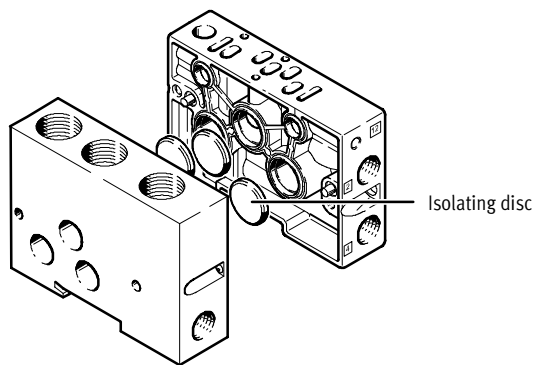

- The figure shows the isolating discs inserted between the adapter plate and valve sub-base.
- Other positioning options are possible (e.g. between two valve sub-bases).

Cover caps

Technical data



Blanking plates allow connections that are not currently required to be sealed off. They guarantee the following functions:

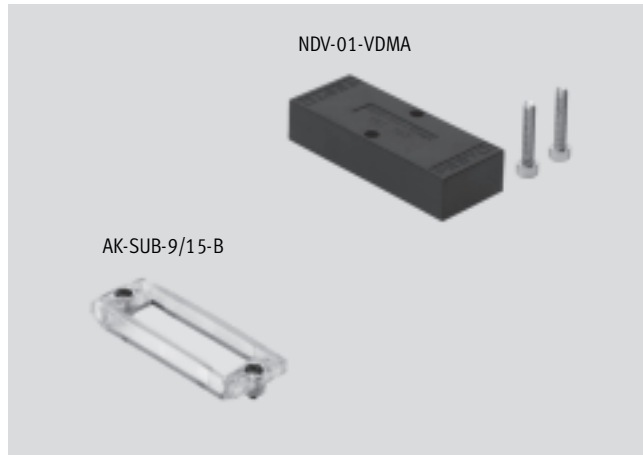

- Operation of the respective component
- Attainment of a protection class
- Hazard prevention (e.g. by covering current carrying parts)



Ordering data								
View	Product weight [g]	Material	Mounting	Operating pressure [bar]	Protection class to EN 60 529 (assembled)	Dimensions (LxWxH) [mm]	Part No.	Type
	20	Polyamide PACM12 (Trogamid), transparent	2 M3x10 screws	–	IP65, IP67	62 x 20 x 8	533 334	AK-SUB-9/15-B
	10	Polyamid PACM12 (Trogamid), transparent	2 M3x14 screws	–	IP65, IP67	20 x 33 x 8	534 496	AK-Rj45
	103	Polypropylene (Celstran)	2 M3x45 screws	–0.9...10	IP65/67	158 x 24 x 42	196 667	CDVI5.0-A-P-1
							193 140	CDVI5.0-A-P-2
	7	Semi-aromatic polyamide (Sucanul)	2 M2x10 screws	10	–	41 x 12.6 x 9.3	527 062	CPASC1-RP
	19	–	–	–0.9...7	IP40	–	527 527	CPASC1-RP-B
	19	–	–	–0.9...7	IP40	–	527 575	CPVSC1-RP
	98	Die-cast aluminium (GD-ALS12)	2 M4x12 screws	–	–	170.6 x 32 x 11	18 068	IAP-02-1/4
	80	Die-cast aluminium (GD-ALS12)	2 M4x12 screws	–	–	159.1 x 26 x 11	18 067	IAP-02-1/8

Cover caps

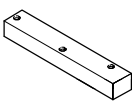
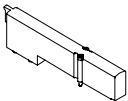
Technical data

Ordering data								
View	Product weight [g]	Material	Mounting	Operating pressure [bar]	Protection class to EN 60 529 (assembled)	Dimensions (LxWxH) [mm]	Part No.	Type
	73	Die-cast aluminium (GD-ALSI12)	2 M4x12 screws	-0.9...10	-	150 x 24 x 17	18 745	IAP-03-7,0
	22	Polyamide 6, (LNP)	3 M3x14 screws	-0.9...10	-	115 x 18 x 8	18 648	IAP-03.4,0
	32	Semi-aromatic polyamide (IXEF 1022)	2 M2x22 screws	Max. 25	-	102.4 x 12.6 x 18.4	533 351	VMPA1-RP¹⁾
	35	Polyamide 6, (LNP)	2 M4x20 screws	Max. 16	-	66 x 26 x 14	161 107	NDV-01-VDMA

1) A self-adhesive label is supplied.

Examples illustrating the attachment of a blanking plate

CPV10-VI-...

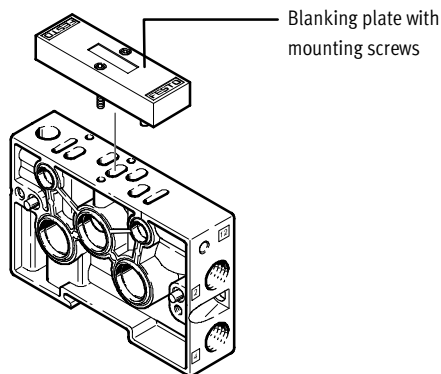

- The blanking plate is mounted instead of a valve on the valve terminal.
- A seal between the blanking plate and sub-base closes the connection with a pressure tight seal.
- The blanking plate AK-SUB-9/15-B is an exception. It is used to cover a vacant electrical connection and is therefore less pressure resistant.

Cover caps

Technical data – Cover caps for manual override



These protective caps allow manual overrides to be locked. They are also protected against accidental actuation.



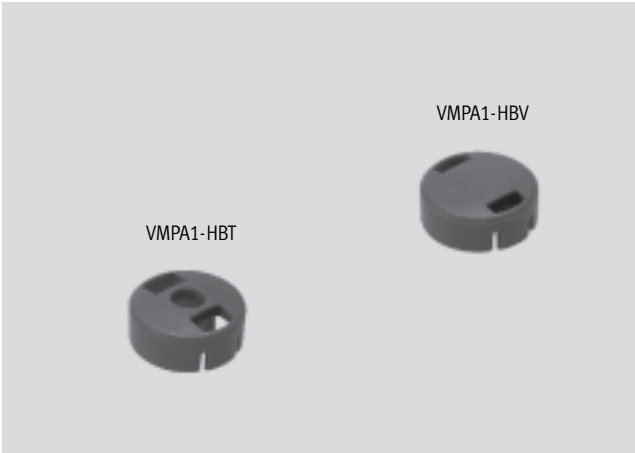

 Note

It is recommended that you use a pointed tool (screwdriver) to remove the covers from the manual override. Re-use is not advisable.



Accessories for valve terminals
Cover caps

5.2

Ordering data						
View	Product weight [g]	Function	Material	Dimensions [mm]	Part No.	Type
	3	Locks the manual override (turning with detent) in the unactuated position and at the same time enables the non-detenting manual override.	Polyacetal (Delrin)	Ø 9.8	533 366	VMPA1-HBT
	3	Locks the manual override (turning with detent) in the unactuated position and at the same time covers the non-detenting manual override.	Polyacetal (Delrin)	Ø 9.8	535 257	VMPA1-HBV
	2	Covers the manual override (turning with detent) in the actuated or unactuated position.	Polyacetal (Delrin)	Ø 10.1	527 393	CPASC1-MO-V
					527 642	CPVSC1-HV
	2.7	Locks the detenting manual override in the actuated or unactuated position. When the detenting manual override is in the unactuated position, the non-detenting manual override is covered at the same time.	Polyacetal CoPo (Hostaform)	HxW: 8.2 x 9.6	530 055	CPV10/14-HV
	7.7				530 056	CPV18-HV
					526 235	CPV18-HHB-VU
	1.7	Locks the detenting manual override in the actuated or unactuated position.	Polyacetal HoPo (Delrin)	HxW: 3.5 x 9.6	526 203	CPV10/14-HS
	5.1				526 204	CPV18-HS
					526 237	CPV18-HHB-T
			Polycarbonate (Makrolon)	HxW: 6.1 x 17.2		

Cover caps

Technical data

Examples illustrating the attachment of protective caps to manual overrides

Manual override, detenting via turning

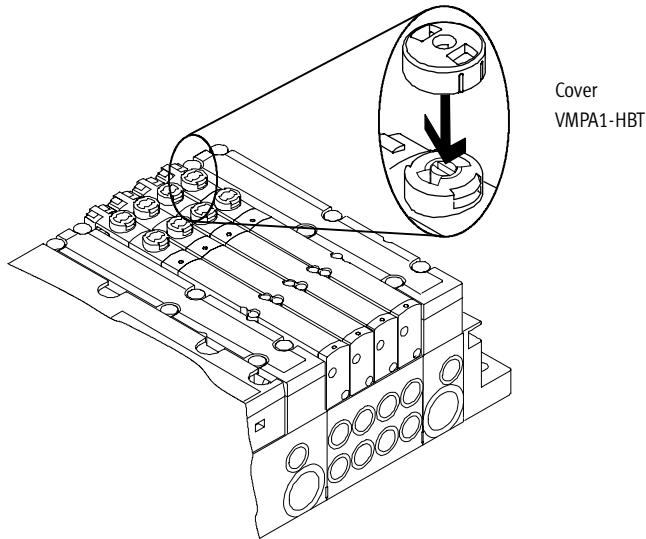

- The protective cap is placed on the manual override and locked into position.

Manual override, detenting with slide

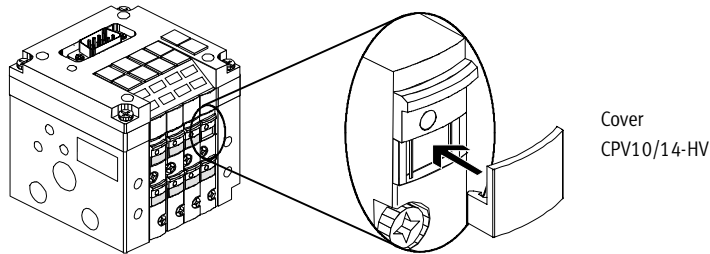

- The manual override is brought into the desired position (unactuated) and the cover is placed on the slide track of the manual override and locked into position.

Cover caps



Technical data – Plugs



Plugs are inserted/screwed into connections that are not required in order to close these. They guarantee the following functions:

- Operation of the respective component
- Attainment of a protection class
- Hazard prevention (e.g. by covering current carrying parts)

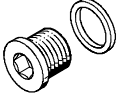



Ordering data								
View	Product weight [g]	Material	Drive	Thread	Length [mm]	Special features	Part No.	Type
	0.8	Wrought aluminium alloy	External hexagon SW7	M5	8	IP65 (assembled)	3 843	B-M5
	1.2	Free cutting steel	Internal hexagon SW2.5	M5	6.5	IP65 (assembled)	174 308	B-M5-B
	2.6		Internal hexagon SW3	M7	8	IP65 (assembled)	174 309	B-M7
	6.8	Galvanised steel	Internal hexagon SW5	G1/8	11	IP65 (assembled)	3 568	B-1/8
	15.3		Internal hexagon SW6	G1/4	15	IP65 (assembled)	3 569	B-1/4
	24		Internal hexagon SW8	G3/8	15	IP65 (assembled)	3 570	B-3/8
	42		Internal hexagon SW10	G1/2	18	IP65 (assembled)	3 571	B-1/2
		Wrought aluminium alloy	External hexagon SW8	M6	14.4	CRC 4 ¹⁾ IP65/67 (assembled)	532 476	CDVI-5.0-B-M6
	9.9		External hexagon SW10	G1/8	14		196 720	CDVI-5.0-B-G1/8
	35.1		External hexagon SW15	G3/8	21.5		196 712	CDVI-5.0-B-G3/8
	6.9	Polyamide 6, (Wellamid)	External hexagon SW11/Phillips screwdriver H3	M8	10.5	IP65 (assembled)	177 672	ISK-M8
	1.5		External hexagon SW14/Phillips screwdriver H3	M12	13.5	IP65 (assembled)	165 592	ISK-M12

¹⁾ Corrosion resistance class 4 according to Festo standard 940 070
Components requiring higher corrosion resistance. Parts used with aggressive media, e.g. food or chemical industry. These applications should be supported with special tests with the media if required.

Cover caps

Technical data – Plugs

Ordering data								
View	Product weight [g]	Material	Drive	Dia. of sealable opening	Length [mm]	Special features	Part No.	Type
	17.4	High-alloy steel (X14CrMoS17), galvanised steel,	External hexagon SW8/slotted head screwdriver	G 1/4	16.2	-0.95 ... 16 bar hermetically sealed	160 997	PRSV-1/8
	26.7	polyacetal, NBR	External hexagon SW10/slotted head screwdriver	G 3/8	17.3	-0.95 ... 16 bar hermetically sealed	160 996	PRSV-1/4
	0.3	Polybuteneter-ephthalate	Pushed in by hand	3 mm	22	-0.95 ... 10 bar hermetically sealed	153 382	QSMC-3H
	0.5			4 mm	28		153 267	QSC-4H
	0.5			6 mm	33		153 268	QSC-6H
	1			8 mm	37		153 269	QSC-8H
	2			10 mm	42		153 270	QSC-10H
	2.5			12 mm	44		153 271	QSC-12H
				7	Polyamide 6, (Ultramid)		Pushed in by hand	2...2.7 mm

Examples illustrating the fitting of plugs

B...

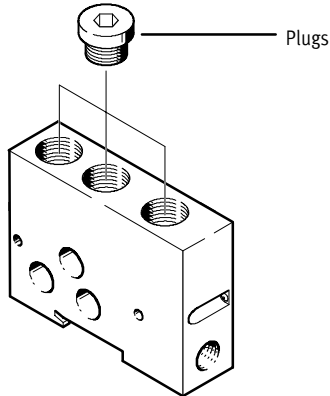

■ Plugs are screwed or pushed into the openings to be sealed.

-  - Note

When re-using plugs, check the seal and replace if necessary.