

Clamping unit cylinders DNCKE, standard port pattern

FESTO



- Holding and clamping in the event of a power failure
- Up to 2,000 mm stroke
- Extensive range of accessories

Clamping unit cylinders DNCKE, standard port pattern

Key features

FESTO

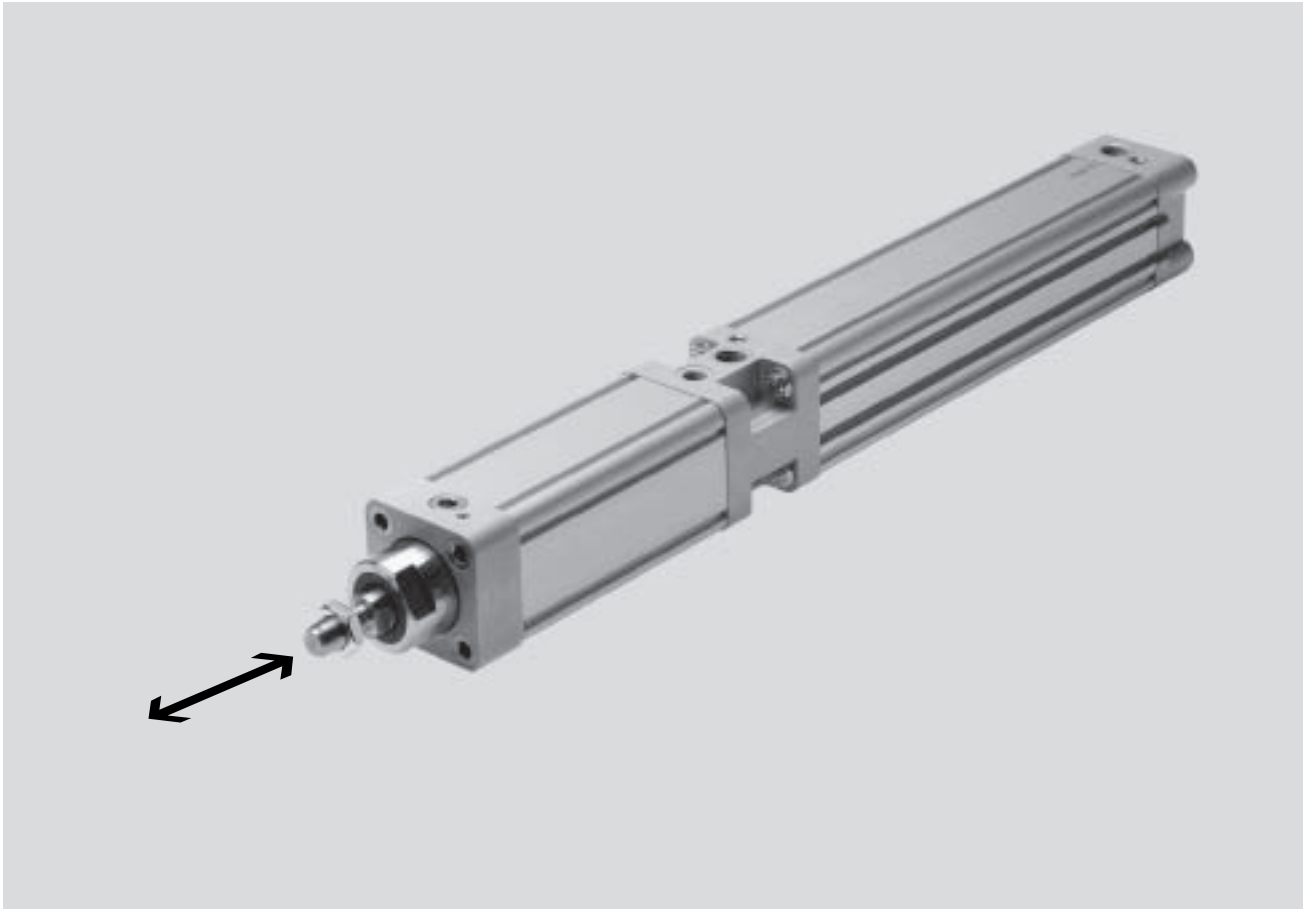

Reliable

- Clamping force is released when compressed air is fed to the clamping unit

Powerful

- Static holding force of up to 8,000 N
- Holding and clamping in the event of a power failure
- Protection against pressure failure and pressure drop

More than the standard

- The cylinders comply with DIN ISO 6431, except where length is concerned.

Easy to assemble

- Wide selection of mounting options

Clamping unit cylinders DNCKE, standard port pattern

Key features and overview

General information

Clamping units are generally used for the friction locking of longitudinally variable rods at any position. The attachment of a clamping unit to a pneumatic cylinder allows the piston

rod to be clamped. This clamping unit is designed to lock the piston rod securely so that the application of external force on the piston rod does not produce any relative motion. The

locking of the piston rod can take place at any position in the stroke, in the end positions as well as the intermediate positions. This provides

protection in the event of a pressure failure and secures the piston rod during intermediate stops for process operations.

Special features when using the DNCKE with safety-related applications

Safety-related applications that are used as cushioning devices are designed to cushion and stop unsafe movements through the application of clamping force on the piston rod. Safety-related applications that are used as holding devices are designed to hold loads in the normal position through the application of clamping force on the piston rod.

The clamping unit cylinder DNCKE is fail-safe and corresponds to category 1 to EN 954-1. It can be used in safety-related sections of control systems belonging to a higher category (EN 954-1) in compliance with other valid standards (e.g. EN 292, EN 1050, EN 983, C standards etc.).

Products intended for use in safety-related applications must be selected, sized and arranged in accordance with the risk assessment (EN 1050) as well as any other valid standards and regulations. This is the responsibility of the system manufacturer.

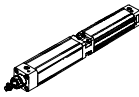
Function	Version	Type	Piston Ø [mm]	Stroke [mm]	Cushioning adjustable PPV	Position sensing A
Double-acting		DNCKE	40	10 ... 2,000	■	■
		With clamping unit	63	10 ... 2,000		
			100	10 ... 2,000		

Clamping unit cylinders DNCKE, standard port pattern

Peripherals overview

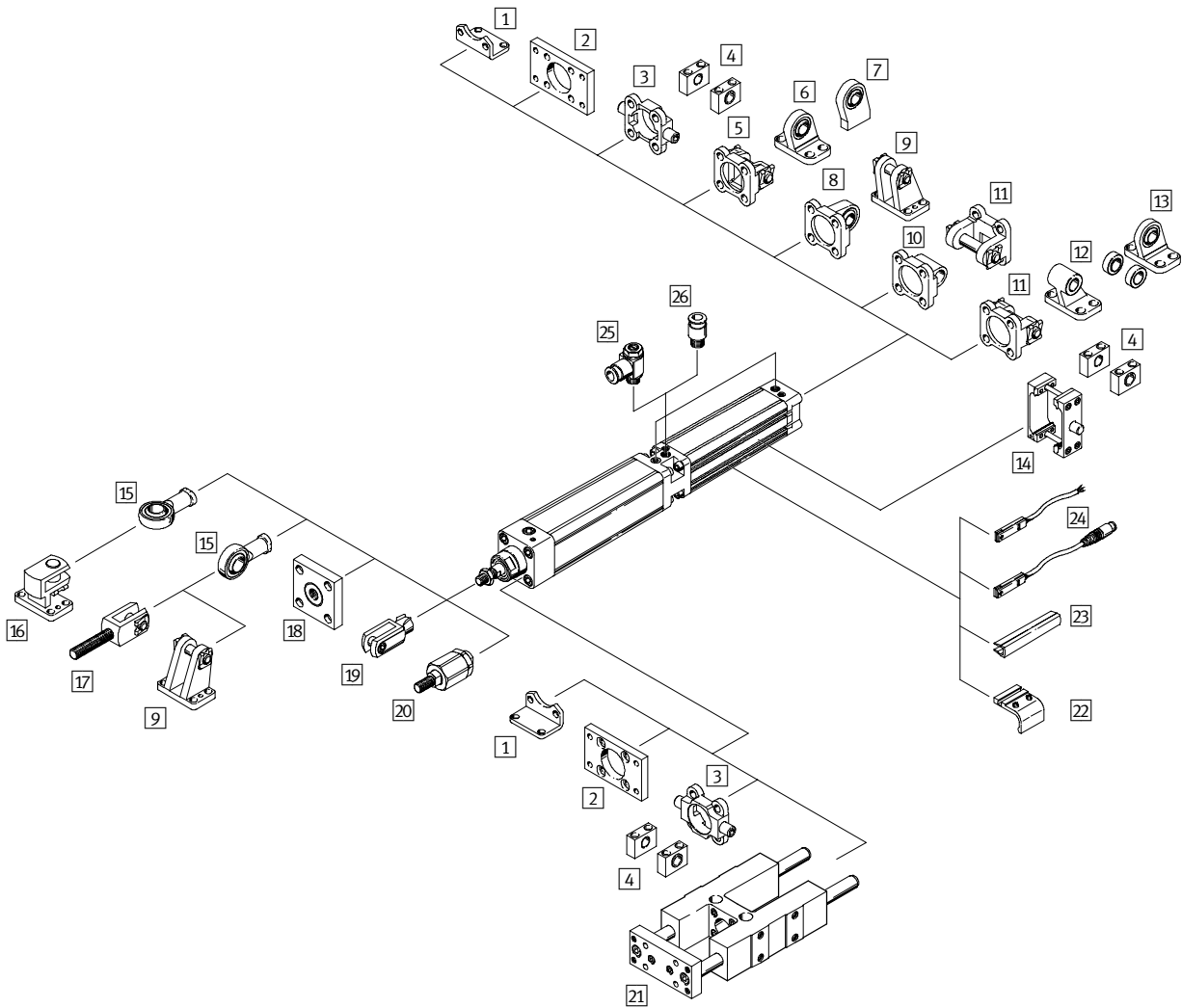

Clamping unit cylinders DNCKE, standard port pattern

Peripherals overview

Mounting attachments and accessories		
	Brief description	→ Page
1	Foot mounting HNC	For bearing or end caps 1 / 5.11-11
2	Flange mounting FNC	For bearing or end caps 1 / 5.11-11
3	Trunnion flange ZNCF	For bearing or end caps 1 / 5.11-12
4	Trunnion support LNZG	– 1 / 5.11-13
5	Swivel flange SNC	For end caps 1 / 5.11-13
6	Clevis foot LSNG	With spherical bearing 1 / 5.11-15
7	Clevis foot LSNSG	Weld-on, with spherical bearing 1 / 5.11-15
8	Swivel flange SNCS	With spherical bearing for end caps 1 / 5.11-14
9	Clevis foot LBG	– 1 / 5.11-15
10	Swivel flange SNCL	For end caps 1 / 5.11-15
11	Swivel flange SNCB	For end caps 1 / 5.11-14
12	Clevis foot LNG	– 1 / 5.11-15
13	Clevis foot LSN	With spherical bearing 1 / 5.11-15
14	Trunnion mounting kit ZNCM	For mounting anywhere along the cylinder profile barrel 1 / 5.11-12
15	Rod eye SGS	With spherical bearing 1 / 5.11-16
16	Right-angle clevis foot LQG	– 1 / 5.11-15
17	Rod clevis SGA	With male thread 1 / 5.11-16
18	Coupling piece KSG	For compensating radial deviations 1 / 5.11-16
19	Rod clevis SG	Permits a swivelling movement of the cylinder in one plane 1 / 5.11-16
20	Self-aligning rod coupler FK	For compensating radial and angular deviations 1 / 5.11-16
21	Guide unit FENG	For protecting standard cylinders from torsion at high torque loads 1 / 5.11-16
22	Mounting kit SMB-8-FENG	For proximity sensor SMT-8 when attaching to cylinders in combination with guide unit FENG 1 / 5.11-17
23	Slot cover ABP-5-S	To protect the sensor cable and keep dirt out of the sensor slots 1 / 5.11-18
24	Proximity sensor SME/SMT-8	Can be integrated in the cylinder profile barrel 1 / 5.11-17
25	One-way flow control valve GRLA	To regulate speed 1 / 5.11-18
26	Push-in fitting QS	For connecting compressed air tubing with standard external diameters to CETOP RP54 P Volume 3

Clamping unit cylinders DNCKE, standard port pattern

Type codes

DNCKE – 63 – 100 – PPV – A

Type

Double-acting
 DNCKE Clamping unit cylinder

Piston \varnothing [mm]

Stroke [mm]

Cushioning

PPV Adjustable at both ends

Position sensing



A With proximity sensor

Clamping unit cylinders DNCKE, standard port pattern

Technical data

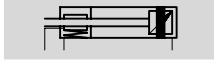
Function



-  - Diameter
40, 63, 100 mm
-  - Stroke length
10 ... 2 000 mm

General technical data				
Piston Ø		40	63	100
Pneumatic connection	Cylinder	G $\frac{1}{4}$	G $\frac{3}{8}$	G $\frac{1}{2}$
	Clamping unit	G $\frac{1}{8}$	G $\frac{1}{4}$	G $\frac{3}{8}$
Piston rod thread		M12x1.25	M16x1.5	M20x1.5
Clamping type with effective direction		Both ends, spring \rightarrow compressed air		
Constructional design		Piston		
		Piston rod		
		Cylinder barrel		
Cushioning		Adjustable at both ends		
Cushioning length [mm]		20	22	32
Position sensing		With proximity sensor		
Type of mounting		With female thread		
		Via accessories		
Mounting position		Any		

Operating and environmental conditions				
Piston Ø		40	63	100
Operating medium		Filtered compressed air, lubricated or unlubricated		
Operating pressure [bar]		0.6 ... 10		
Min. release pressure [bar]		3.8		
Ambient temperature ¹⁾ [°C]		-20 ... +80		
Corrosion resistance class CRC ²⁾		2 (except piston rod and internal hardened steel parts of the clamping unit)		

1) Note operating range of proximity sensors.

2) Corrosion resistance class 2 according to Festo standard 940 070

Components requiring moderate corrosion resistance. Externally visible parts with primarily decorative surface requirements which are in direct contact with a surrounding industrial atmosphere or media such as cooling or lubricating agents.

Clamping unit cylinders DNCKE, standard port pattern

Technical data

Forces [N]			
Piston Ø	40	63	100
Theoretical force at 6 bar, advancing	754	1,870	4,712
Theoretical force at 6 bar, retracting	633	1,682	4,418
Static holding force	1,300	3,200	8,000

 - Note

The specified holding force refers to a static load. If this value is exceeded, slippage may occur. Dynamic forces occurring during operation must not exceed the static holding force if slippage is to be avoided.

The clamping unit is not backlash-free in the clamped condition if varying loads are applied to the piston rod.

Activation:

The clamping unit may only be released when equilibrium of forces is present on the piston rod. Otherwise there is a risk of accident due to the sudden movement of the piston rod. Blocking off the air supply at both ends (e.g. with a 5/3-way valve) does not provide any safety.

Impact energy [J]			
Piston Ø	40	63	100
Max. impact energy at end positions	0.7	1.3	3

Permissible impact velocity:

$$v_{perm.} = \sqrt{\frac{2 \times E_{perm.}}{m_{dead} + m_{load}}}$$

Maximum permissible load:

$$m_{load} = \frac{2 \times E_{perm.}}{v^2} - m_{dead}$$

 - Note

This data represents the maximum values which can be achieved. Values fluctuate in practice relative to the size of the effective load. Allowance must also be made for the limits of the cushioning capacity of the drive and the permissible impact energy.

Weights [g]			
Piston Ø	40	63	100
Product weight at 0 mm stroke	2,340	5,485	18,160
Additional weight per 10 mm stroke	45	73	110
Moving load at 0 mm stroke	500	935	2,150
Additional load per 10 mm stroke	16	25	40

Clamping unit cylinders DNCKE, standard port pattern

Technical data

Materials

Sectional view

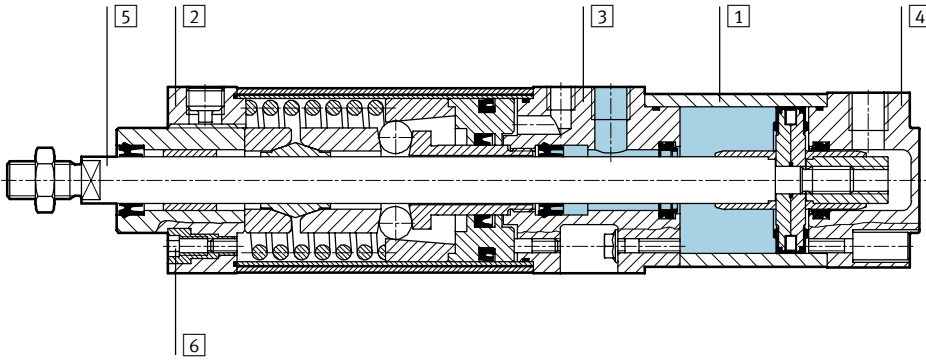

Cylinder

1	Housing	Wrought aluminium alloy
2	Bearing cap	Wrought aluminium alloy
3	Connector cap	Wrought aluminium alloy
4	End cap	Die-cast aluminium
5	Piston rod	Tempered steel
6	Flange screws	Tempered steel
-	Seals	Polyurethane, nitrile rubber

Clamping unit cylinders DNCKE, standard port pattern

Technical data

Dimensions Download CAD data → www.festo.com/en/engineering

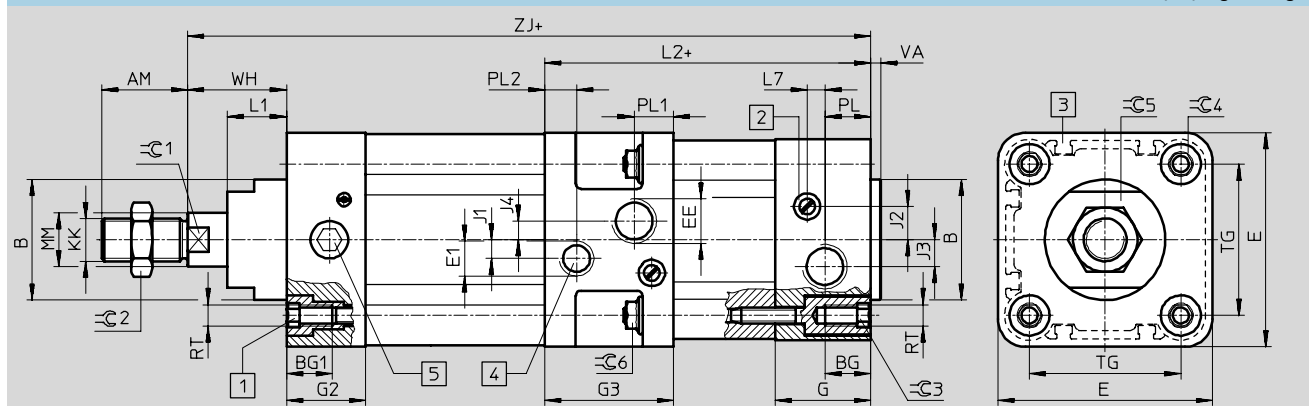

1 Socket head screw with female thread for mounting attachments
2 Regulating screw for adjustable end-position cushioning
3 Sensor slot for proximity sensor
4 Connection to release clamping function
5 Locking screw

+ = plus stroke length

∅	AM	B ∅ d11	BG	BG1	E	EE	E1	G	G2	G3	J1
40	24	35	16	15	54	G ¹ / ₄	G ¹ / ₈	28.8	22	49.6	2
63	32	45	17	17	80	G ³ / ₈	G ¹ / ₄	34.3	29.5	47.9	7
100	42	55	17	17	126	G ¹ / ₂	G ³ / ₈	38	32.5	46.7	15

∅	J2	J3	J4	KK	L1	L2	L7	MM ∅ f8	PL	PL1	PL2
40	8	6	0	M12x1.25	17.9	114.5	3.6	16	14	21.3	9
63	12.4	10	7	M16x1.5	22.1	121.5	6.6	20	17	14.6	11.8
100	12	10	10	M20x1.5	29.2	131.5	8	25	18.8	16.4	14.4

∅	RT	TG	VA	WH	ZJ	∅C1	∅C2	∅C3	∅C4	∅C5	∅C6
40	M6	38	4	30	277	13	19	6	6	30	8
63	M8	56.5	4	37	315	17	24	8	8	36	10
100	M10	89	4	51	408	22	30	6	10	41	13

Ordering data			
Piston ∅ [mm]	Stroke [mm]	Part No.	Type
40	10 ... 2,000	526 482	DNCKE-40-...-PPV-A
63	10 ... 2,000	526 483	DNCKE-63-...-PPV-A
100	10 ... 2,000	526 484	DNCKE-100-...-PPV-A

Clamping unit cylinders DNCKE, standard port pattern



Accessories

Foot mounting HNC

Material:
Galvanised steel
Free of copper, PTFE and silicone

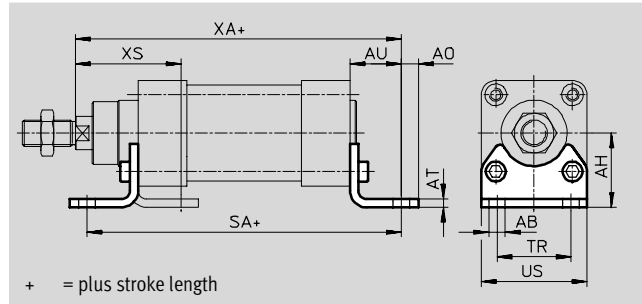

Dimensions and ordering data														
For \varnothing	AB	AH	AO	AT	AU	SA	TR	US	XA	XS	CRC ¹⁾	Weight	Part No.	Type
[mm]	\varnothing											[g]		
40	10	36	9	4	28	303	36	54	305	53	2	180	174 370	HNC-40
63	10	50	12.5	5	32	342	50	75	347	63	2	405	174 372	HNC-63
100	14.5	71	17.5	6	41	439	75	110	449	86	2	1 000	174 374	HNC-100

1) Corrosion resistance class 2 according to Festo standard 940 070
Components requiring moderate corrosion resistance. Externally visible parts with primarily decorative surface requirements which are in direct contact with a surrounding industrial atmosphere or media such as cooling or lubricating agents.

Flange mounting FNC

Material:
Galvanised steel
Free of copper, PTFE and silicone

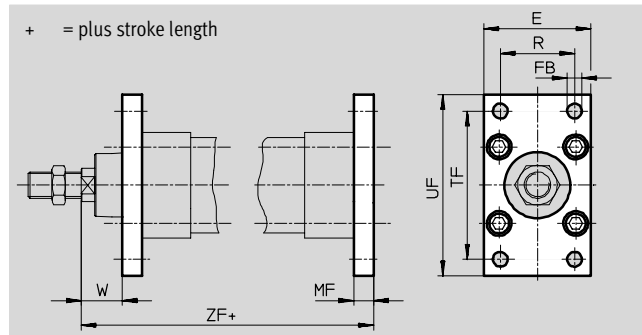

Dimensions and ordering data													
For \varnothing	E	FB	MF	R	TF	UF	W	ZF	CRC ¹⁾	Weight	Part No.	Type	
[mm]		\varnothing H13								[g]			
40	54	9	10	36	72	90	20	287	2	280	174 377	FNC-40	
63	75	9	12	50	100	120	25	327	2	690	174 379	FNC-63	
100	110	14	16	75	150	175	35	424	2	2 400	174 381	FNC-100	

1) Corrosion resistance class 2 according to Festo standard 940 070
Components requiring moderate corrosion resistance. Externally visible parts with primarily decorative surface requirements which are in direct contact with a surrounding industrial atmosphere or media such as cooling or lubricating agents.

Clamping unit cylinders DNCKE, standard port pattern

Accessories



Trunnion flange ZNCF

Material:
Corrosion resistant cast steel
Free of copper, PTFE and silicone

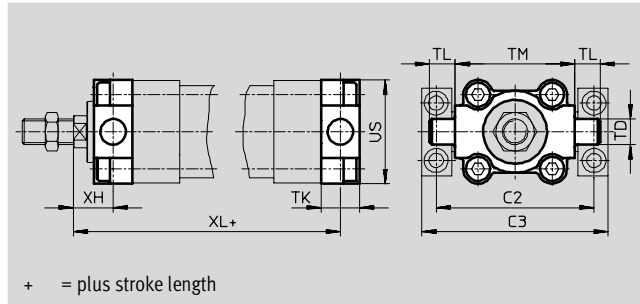

Dimensions and ordering data													
Fo r∅	C2	C3	TD	TK	TL	TM	US	XH	XL	CRC ¹⁾	Weight	Part No.	Type
[mm]			∅ e9								[g]		
40	87	105	16	20	16	63	54	20	287	2	240	174 412	ZNCF-40
63	116	136	20	24	20	90	75	25	327	2	600	174 414	ZNCF-63
100	164	189	25	38	25	132	110	32	427	2	2 030	174 416	ZNCF-100

1) Corrosion resistance class 2 according to Festo standard 940 070
Components requiring moderate corrosion resistance. Externally visible parts with primarily decorative surface requirements which are in direct contact with a surrounding industrial atmosphere or media such as cooling or lubricating agents.

Trunnion mounting kit ZNCM

The mounting kit can be attached at any position along the profile barrel of a cylinder.

Material:
Tempered steel

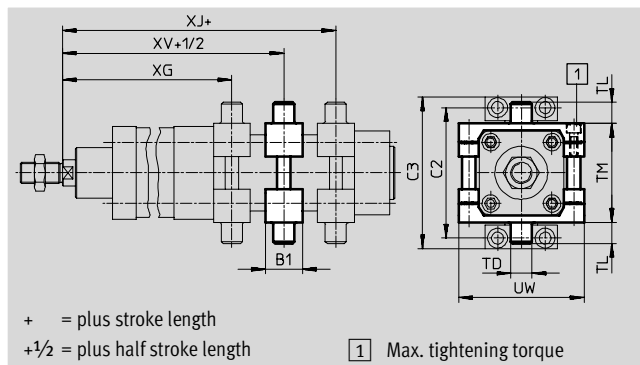

Dimensions and ordering data							
For ∅	B1	C2	C3	TD	TL	TM	UW
[mm]				∅ e9			
40	32	87	105	16	16	63	75
63	41	116	136	20	20	90	105
100	48	164	189	25	25	132	145

For ∅	XG	XJ	XV	Max. tightening torque	CRC ¹⁾	Weights	Part No.	Type
[mm]				[Nm]		[g]		
40	228.1	232.2	230.2	8+1	2	385	163 526	ZNCM-40
63	261.9	260.2	261	18+2	2	890	163 528	ZNCM-63
100	347.2	346	346.6	28+2	2	2,045	163 530	ZNCM-100

1) Corrosion resistance class 2 according to Festo standard 940 070
Components requiring moderate corrosion resistance. Externally visible parts with primarily decorative surface requirements which are in direct contact with a surrounding industrial atmosphere or media such as cooling or lubricating agents.

Core Range

Clamping unit cylinders DNCKE, standard port pattern

Accessories

Trunnion support LNZG

Material:
Galvanised steel
Free of copper, PTFE and silicone

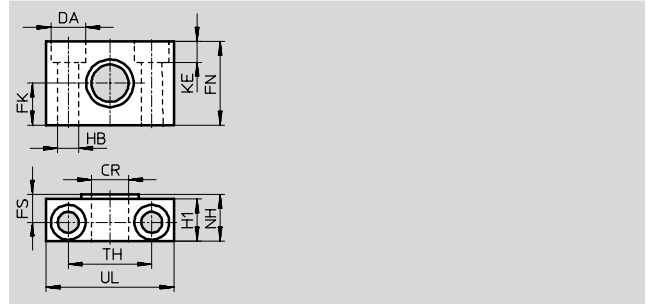
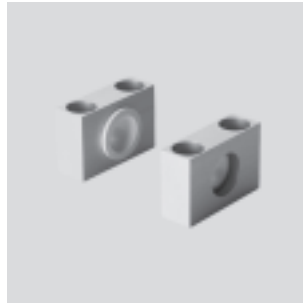

Dimensions and ordering data															
For \varnothing	CR	DA	FK	FN	FS	H1	HB	KE	NH	TH	UL	CRC ¹⁾	Weight	Part No.	Type
[mm]	\varnothing D11	\varnothing H13	\varnothing ± 0.1				\varnothing H13			± 0.2			[g]		
40	16	15	18	36	12	18	9	9	21	36	55	2	400	32 960	LNZG-40/50
63	20	18	20	40	13	20	11	11	23	42	65	2	480	32 961	LNZG-63/80
100	25	20	25	50	16	24.5	14	13	28.5	50	75	2	960	32 962	LNZG-100/125

1) Corrosion resistance class 2 according to Festo standard 940 070
Components requiring moderate corrosion resistance. Externally visible parts with primarily decorative surface requirements which are in direct contact with a surrounding industrial atmosphere or media such as cooling or lubricating agents.

Swivel flange SNC

Material:
Wrought aluminium alloy

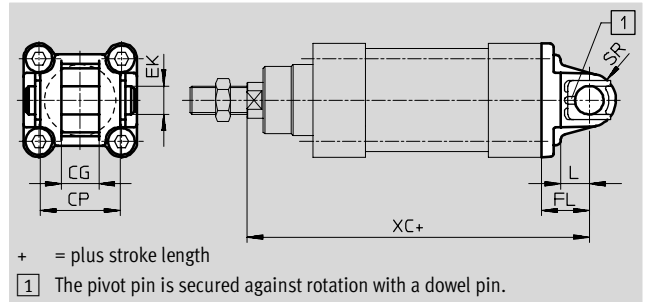

Dimensions and ordering data											
For \varnothing	CG	CP	EK	FL	L	SR	XC	CRC ¹⁾	Weight	Part No.	Type
[mm]	H14	d12	\varnothing	± 0.2					[g]		
40	16	40	12	25	16	12	302	2	120	174 384	SNC-40
63	21	51	16	32	21	16	347	2	320	174 386	SNC-63
100	25	75	20	41	27	20	449	2	830	174 388	SNC-100

1) Corrosion resistance class 2 according to Festo standard 940 070
Components requiring moderate corrosion resistance. Externally visible parts with primarily decorative surface requirements which are in direct contact with a surrounding industrial atmosphere or media such as cooling or lubricating agents.

Clamping unit cylinders DNCKE, standard port pattern

Accessories



Swivel flange SNCB

Material:
Wrought aluminium alloy
Free of copper, PTFE and silicone

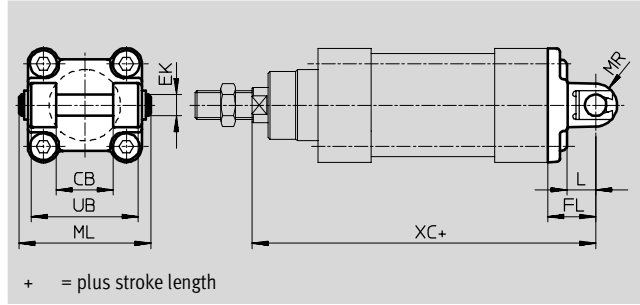

Dimensions and ordering data												
For \varnothing	CB	EK	FL	L	ML	MR	UB	XC	CRC ¹⁾	Weight	Part No.	Type
[mm]	H14	\varnothing e8	± 0.2				h14			[g]		
40	28	12	25	16	63	12	52	302	2	150	174 391	SNCB-40
63	40	16	32	21	83	16	70	347	2	365	174 393	SNCB-63
100	60	20	41	27	127	20	110	449	2	925	174 395	SNCB-100

1) Corrosion resistance class 2 according to Festo standard 940 070
Components requiring moderate corrosion resistance. Externally visible parts with primarily decorative surface requirements which are in direct contact with a surrounding industrial atmosphere or media such as cooling or lubricating agents.

Swivel flange SNCS

Material:
Wrought aluminium alloy

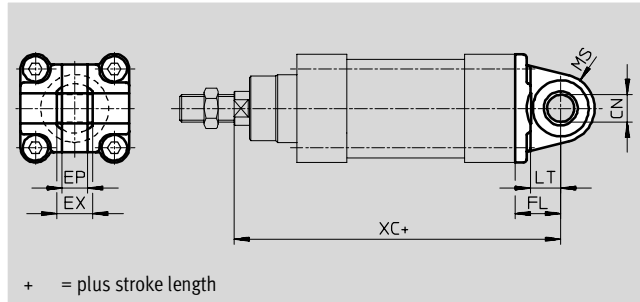
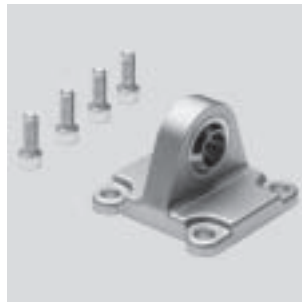

Dimensions and ordering data											
For \varnothing	CN	EP	EX	FL	LT	MS	XC	CRC ¹⁾	Weight	Part No.	Type
[mm]	\varnothing	-0.2		± 0.2					[g]		
40	12	12	16	25	16	17	302	2	125	174 398	SNCS-40
63	16	15	21	32	21	22	347	2	280	174 400	SNCS-63
100	20	18	25	41	27	29	449	2	700	174 402	SNCS-100

1) Corrosion resistance class 2 according to Festo standard 940 070
Components requiring moderate corrosion resistance. Externally visible parts with primarily decorative surface requirements which are in direct contact with a surrounding industrial atmosphere or media such as cooling or lubricating agents.

Core Range

Clamping unit cylinders DNCKE, standard port pattern

Accessories

Swivel flange SNCL

Material:
Wrought aluminium alloy
Free of copper, PTFE and silicone

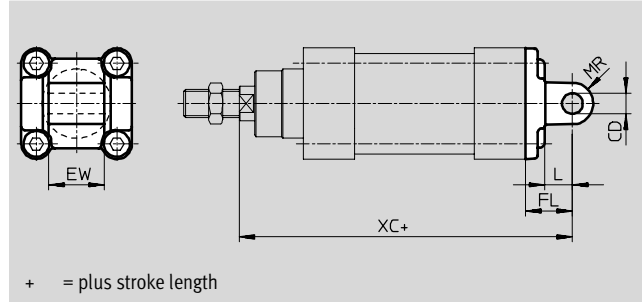
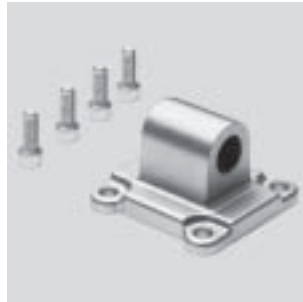

+ = plus stroke length

Dimensions and ordering data										
For Ø	CD	EW	FL	L	MR	XC	CRC ¹⁾	Weight	Part No.	Type
[mm]	Ø	h14	±0.2					[g]		
40	12	28	25	16	12	302	2	100	174 405	SNCL-40
63	16	40	32	21	16	347	2	250	174 407	SNCL-63
100	20	60	41	27	20	449	2	655	174 409	SNCL-100





1) Corrosion resistance class 2 according to Festo standard 940 070
Components requiring moderate corrosion resistance. Externally visible parts with primarily decorative surface requirements which are in direct contact with a surrounding industrial atmosphere or media such as cooling or lubricating agents.

Ordering data – Mounting attachments				Technical data → 1 / 10.1-2			
Designation	For Ø	Part No.	Type	Designation	For Ø	Part No.	Type
Clevis foot LNG				Clevis foot LSN			
	40	33 891	LNG-40		40	5 562	LSN-40
	63	33 893	LNG-63		63	5 564	LSN-63
	100	33 895	LNG-100		100	5 566	LSN-100
Clevis foot LSNG				Clevis foot LSNSG			
	40	31 741	LSNG-40		40	31 748	LSNSG-40
	63	31 743	LSNG-63		63	31 750	LSNSG-63
	100	31 745	LSNG-100		100	31 752	LSNSG-100
Clevis foot LBG				Right-angle clevis foot LQG			
	40	31 762	LBG-40		40	31 769	LQG-40
	63	31 764	LBG-63		63	31 771	LQG-63
	100	31 766	LBG-100		100	31 773	LQG-100

Core Range

Clamping unit cylinders DNCKE, standard port pattern

Accessories

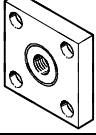
Ordering data – Piston rod attachments				Data sheets → 1 / 10.3-2			
Designation	For Ø	Part No.	Type	Designation	For Ø	Part No.	Type
Rod eye SGS				Rod clevis SGA			
	40	9 262	SGS-M12x1,25		40	10 767	SGA-M12x1,25
	63	9 263	SGS-M16x1,5		63	10 768	SGA-M16x1,5
	100	9 264	SGS-M20x1,5		100	10 769	SGA-M20x1,5
Rod clevis SG				Self-aligning rod coupler FK			
	40	6 145	SG-M12x1,25		40	6 141	FK-M12x1,25
	63	6 146	SG-M16x1,5		63	6 142	FK-M16x1,5
	100	6 147	SG-M20x1,5		100	6 143	FK-M20x1,5
Coupling piece KSG							
	40	32 964	KSG-M12x1,25				
	63	32 965	KSG-M16x1,5				
	100	32 966	KSG-M20x1,5				

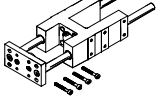
Ordering data – Guide units for fixed strokes (recirculating ball bearing guide only)				Data sheets → 1 / 10.4-2			
	Stroke [mm]	Part No.	Type	Stroke [mm]	Part No.	Type	
	For Ø 40 mm			For Ø 63 mm			
	10 ... 50	34 499	FENG-40-50-KF	10 ... 50	34 513	FENG-63-50-KF	
	10 ... 100	34 500	FENG-40-100-KF	10 ... 100	34 514	FENG-63-100-KF	
	10 ... 160	34 501	FENG-40-160-KF	10 ... 160	34 515	FENG-63-160-KF	
	10 ... 200	34 502	FENG-40-200-KF	10 ... 200	34 516	FENG-63-200-KF	
	10 ... 250	34 503	FENG-40-250-KF	10 ... 250	34 517	FENG-63-250-KF	
	10 ... 320	34 504	FENG-40-320-KF	10 ... 320	34 518	FENG-63-320-KF	
	10 ... 400	150 291	FENG-40-400-KF	10 ... 400	34 519	FENG-63-400-KF	
	10 ... 500	34 505	FENG-40-500-KF	10 ... 500	34 520	FENG-63-500-KF	
	For Ø 100 mm						
	10 ... 50	34 529	FENG-100-50-KF				
	10 ... 100	34 530	FENG-100-100-KF				
	10 ... 160	34 531	FENG-100-160-KF				
	10 ... 200	34 532	FENG-100-200-KF				
	10 ... 250	34 533	FENG-100-250-KF				
	10 ... 320	34 534	FENG-100-320-KF				
	10 ... 400	34 535	FENG-100-400-KF				
	10 ... 500	34 536	FENG-100-500-KF				

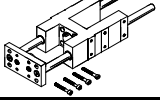







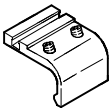

Ordering data – Guide units for variable strokes				Data sheets → 1 / 10.4-2			
	For Ø [mm]	Stroke [mm]	with recirculating ball bearing guide		with plain bearing guide		
			Part No.	Type	Part No.	Type	
	40	10 ... 500	34 488	FENG-40-...-KF	34 482	FENG-40-...	
	63	10 ... 500	34 490	FENG-63-...-KF	34 484	FENG-63-...	
	100	10 ... 500	34 492	FENG-100-...-KF	34 486	FENG-100-...	









 Core Range

Clamping unit cylinders DNCKE, standard port pattern

Accessories

Ordering data – Mounting kit for proximity sensors SMT-8			Data sheets → 1 / 10.2-40	
	For Ø [mm]	Part No.	Type	
	40	175 705	SMB-8-FENG-32/40	
	63	175 706	SMB-8-FENG-50/63	
	100	175 707	SMB-8-FENG-80/100	





Ordering data – Proximity sensor for slot type 8, magneto-resistive						Data sheets → 1 / 10.2-13								
	Mounting	Switch output	Electrical connection			Cable length [m]	Part No.	Type						
			Cable	M8 plug	M12 plug									
NO contact														
	Insertable from above	PNP	3-core	–	–	2.5	525 898	SMT-8F-PS-24V-K2,5-OE						
							525 909	SMT-8F-NS-24V-K2,5-OE						
		–	2-core	–	–	2.5	525 908	SMT-8F-ZS-24V-K2,5-OE						
							PNP	–	3-pin	–	0.3	525 899	SMT-8F-PS-24V-K0,3-M8D	
												525 910	SMT-8F-NS-24V-K0,3-M8D	
–	–	–	3-pin	–	0.3	525 900	SMT-8F-PS-24V-K0,3-M12							
						175 436	SMT-8-PS-K-LED-24-B							
	Insertable from end, flush with the cylinder profile	PNP	3-core	–	–	2.5								
							–	3-pin	–	0.3	175 484	SMT-8-PS-S-LED-24-B		
NC contact														
	Insertable from above	PNP	3-core	–	–	7.5	525 911	SMT-8F-PO-24V-K7,5-OE						

Ordering data – Proximity sensor for slot type 8, magnetic reed					Data sheets → 1 / 10.2-16			
	Mounting	Electrical connection		Cable length [m]	Part No.	Type		
		Cable	M8 plug					
NO contact								
	Insertable from above	3-core	–	2.5	525 895	SME-8F-DS-24V-K2,5-OE		
				5.0	525 897	SME-8F-DS-24V-K5,0-OE		
		2-core	–	2.5	0.3	525 907	SME-8F-ZS-24V-K2,5-OE	
						–	3-pin	–
	Insertable from end, flush with the cylinder profile	3-core	–	2.5	150 855	SME-8-K-LED-24		
				–	3-pin	0.3	150 857	SME-8-S-LED-24
NC contact								
	Insertable from above	3-core	–	7.5	525 906	SME-8F-DO-24V-K7,5-OE		

 Core Range

Clamping unit cylinders DNCKE, standard port pattern

Accessories

Ordering data – Plug sockets						Data sheets → 1 / 10.2-100	
	Mounting	Switch output		Connection	Cable length [m]	Part No.	Type
		PNP	NPN				
Straight socket							
	M8 union nut	■	■	3-pin	2.5	159 420	SIM-M8-3GD-2,5-PU
					5	159 421	SIM-M8-3GD-5-PU
	M12 union nut	■	■	3-pin	2.5	159 428	SIM-M12-3GD-2,5-PU
					5	159 429	SIM-M12-3GD-5-PU
Angled socket							
	M8 union nut	■	■	3-pin	2.5	159 422	SIM-M8-3WD-2,5-PU
					5	159 423	SIM-M8-3WD-5-PU
	M12 union nut	■	■	3-pin	2.5	159 430	SIM-M12-3WD-2,5-PU
					5	159 431	SIM-M12-3WD-5-PU

Ordering data – Slot cover for slot type 8			
	Mounting	Length [m]	Part No. Type
	Insertable from above	2x 0.5	151 680 ABP-5-S

Ordering data – One-way flow control valves				Data sheets → Volume 2	
	Connection		Material	Part No.	Type
	Thread	For tubing O.D.			
	G ¹ / ₈	3	Metal design	193 142	GRLA- ¹ / ₈ -QS-3-D
		4		193 143	GRLA- ¹ / ₈ -QS-4-D
		6		193 144	GRLA- ¹ / ₈ -QS-6-D
		8		193 145	GRLA- ¹ / ₈ -QS-8-D
	G ¹ / ₄	6		193 146	GRLA- ¹ / ₄ -QS-6-D
		8		193 147	GRLA- ¹ / ₄ -QS-8-D
		10		193 148	GRLA- ¹ / ₄ -QS-10-D
	G ³ / ₈	6		193 149	GRLA- ³ / ₈ -QS-6-D
		8		193 150	GRLA- ³ / ₈ -QS-8-D
		10		193 151	GRLA- ³ / ₈ -QS-10-D
	G ¹ / ₂	12		193 152	GRLA- ¹ / ₂ -QS-12-D

 Core Range

- 1 - Type discontinued
Available up until 2005

FESTO

Cylinder with clamping unit DKE

Overview and ordering data

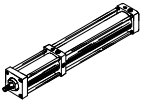
Function	Design	Type	Piston \varnothing [mm]	Stroke [mm]	Cushioning adjustable PPV	Position sensing A
Double-acting		DKE with clamping unit	40	10 ... 2,000	■	■
			63	10 ... 2,000		
			100	10 ... 2,000		



Ordering data		
Piston \varnothing [mm]	Part No.	Type
40	10 093	DKE-40-...-PPV-A ¹⁾
63	10 095	DKE-63-...-PPV-A ¹⁾
100	10 543	DKE-100-...-PPV-A ¹⁾

 **Note**
 For safety-related applications, the cylinder may not be used without additional measures. The cylinder is zero-fault guaranteed as defined by the standard EN 954-1.

To be replaced by clamping unit cylinder DNCKE → 1 / 5.11-2

Technical data
 → The Festo Catalogue on CD-ROM or
 → www.festo.com

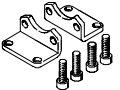
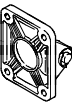
1) The scope of delivery includes a hex nut for the piston rod thread.

Ordering data for accessories – Mounting attachments			
Designation	For \varnothing	Part No.	Type
Foot mounting HN			
	40	5 136	HN-40
	63	5 138	HN-63
	100	5 140	HN-100
Swivel flange SN			
	40	5 154	SN-40
	63	5 156	SN-63
	100	5 158	SN-100
Flange mounting FN			
	40	5 142	FN-40
	63	5 144	FN-63
	100	5 146	FN-100