



- Dynamic and versatile
- Fully compatible with Festo's multi-axis modular system
- Everything from a single source

Toothed belt axes DGE

Key features

At a glance

- Precision, rigid guide
- Highly adaptable, thanks to wide choice of mounting and attachment options
- Wide range of options for attaching drive units
- Comprehensive range of mounting accessories for multi-axis combinations
- Optimally adapted motor controller combinations

Basic version DGE-ZR

- Stroke lengths from 1 ... 4500 mm
- Without guide
- Low characteristic load values



With recirculating ball bearing guide DGE-ZR-KF

- Stroke lengths from 1 ... 4500 mm
- Standard slide or extended slide
- Medium to high characteristic load values



With protected version DGE-ZR-KF-GA

- Stroke lengths from 1 ... 1800 mm
- Standard slide
- Guide and slide are fitted with a cover to protect against the ingress of particles from above and the side



With roller guide DGE-ZR-RF

- Stroke lengths from 1 ... 5000 mm
- Standard slide or extended slide
- Internal, protected roller guide
- Medium characteristic load values
- High speeds possible



With heavy-duty guide DGE-ZR-HD

- Stroke lengths from 1 ... 2000 mm
- High guide precision
- Sturdy construction
- High characteristic load values



Toothed belt axes DGE

Key features

System selection for electromechanical drives

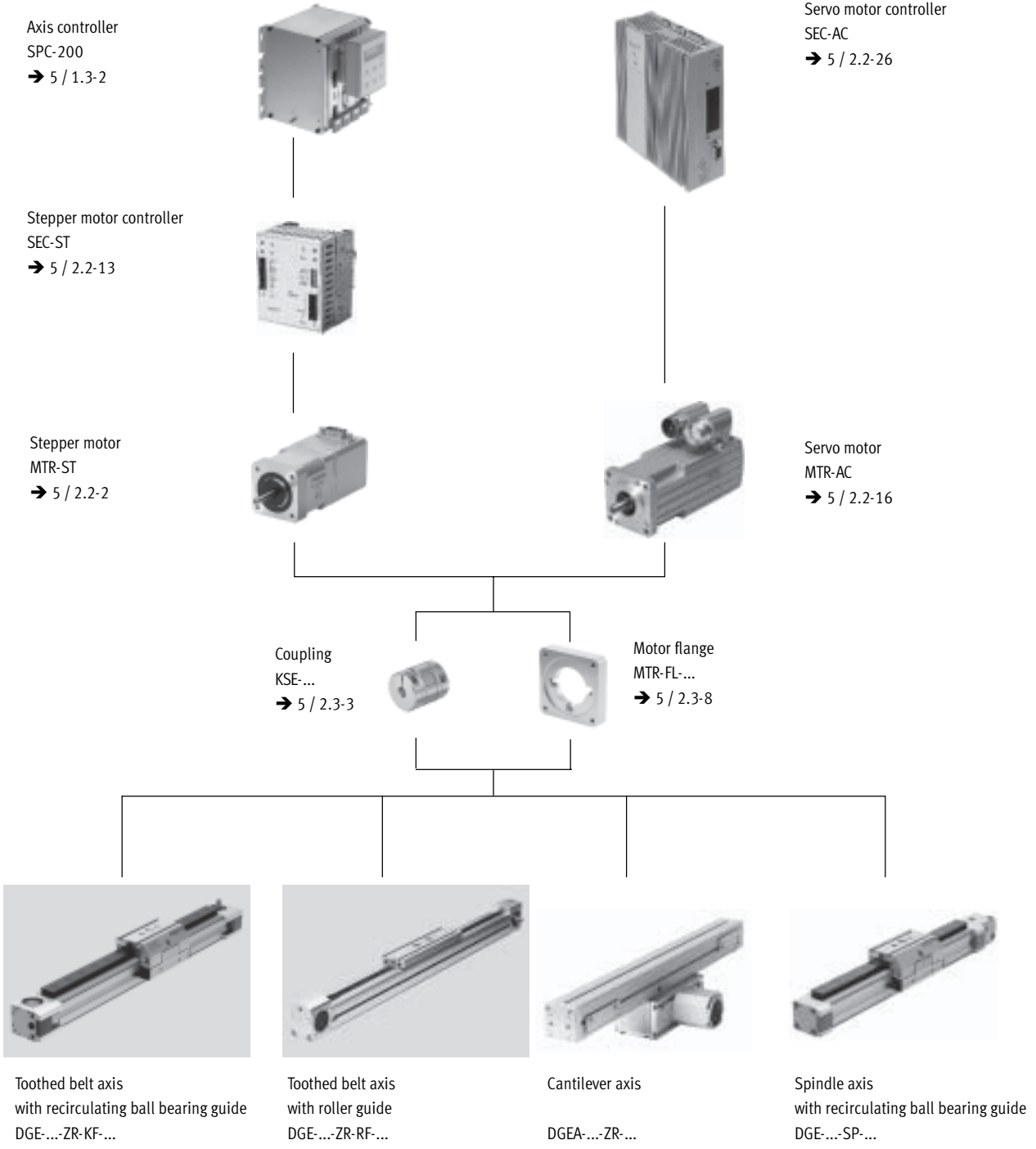

Toothed belt axes DGE

System example

System product for handling and assembly technology

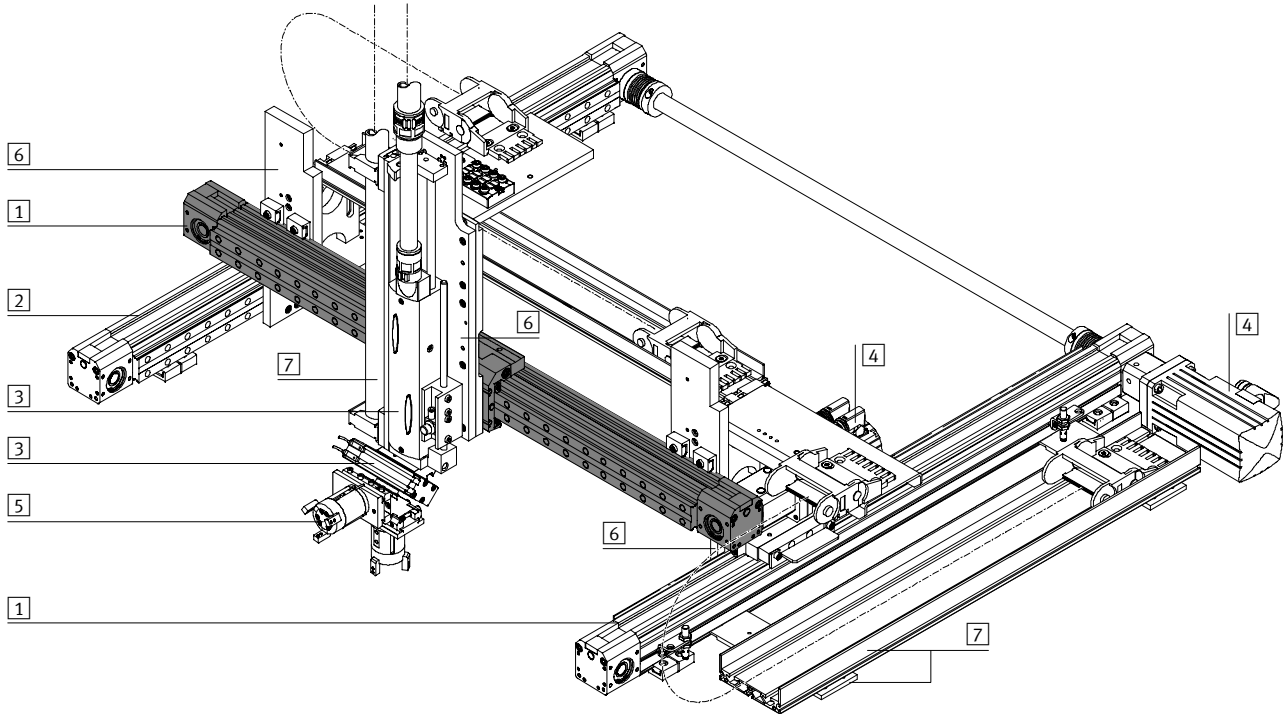

System components and accessories		
Type	Brief description	→ Page
1	Axes	Wide range of combination options within handling and assembly technology Volume 5
2	Passive guide axes	Diverse possible combinations in handling and assembly technology Volume 5
3	Drives	Wide range of combination options within handling and assembly technology Volume 1
4	Motors	Servo and stepper motors, with or without gearing Volume 5
5	Grippers	Wide range of combination options within handling and assembly technology Volume 1
6	Adapters	For combining drives with drives and drives with grippers Volume 5
7	Installation components	For achieving a clear-cut, safe layout for electrical cables and tubing Volume 5

Toothed belt axes DGE

Selection aid

Guide characteristics

The data in the table are maximum values. The precise values for each variant can be found in the corresponding data sheet included in the catalogue.

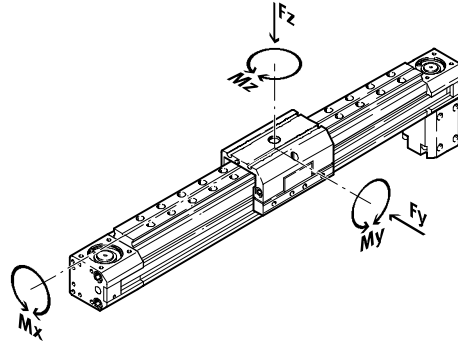

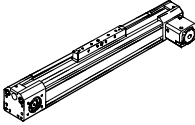
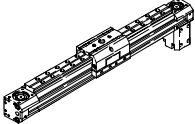
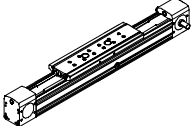
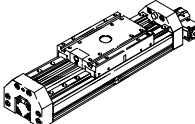
Version	Size	Working stroke ¹⁾ [mm]	Speed [m/s]	Repetition accuracy [mm]	Feed force [N]	Forces and torques					→ Page
						Fy [N]	Fz [N]	Mx [Nm]	My [Nm]	Mz [Nm]	
Basic version without guide ZR											
	8	1 ... 650	1	±0.08	15	-	38	0.15	2	0.3	5 / 2.1-6
	12	1 ... 1000	1.5	±0.08	30	-	59	0.3	4	0.5	
	18	1 ... 1000	2	±0.08	60	-	120	0.5	11	1	
	25	1 ... 3000	5	±0.1	260	-	330	1	20	3	
	40	1 ... 4000	5	±0.1	610	-	800	4	60	8	
	63	1 ... 4500	5	±0.1	1500	-	1600	8	120	24	
With recirculating ball bearing guide ZR-KF											
	8	1 ... 650	1	±0.08	15	255	255	1	3.5	3.5	5 / 2.1-26
	12	1 ... 1000	1.5	±0.08	30	565	565	3	9	9	
	18	1 ... 1000	2	±0.08	60	930	930	7	45	45	
	25	1 ... 3000	3	±0.1	260	3080	3080	45	170	170	
	40	1 ... 4000	3	±0.1	610	7300	7300	170	660	660	
	63	1 ... 4500	3	±0.1	1500	14050	14050	580	1820	1820	
With roller guide ZR-RF											
	25	1 ... 5000	10	±0.1	260	260	150	7	30	30	5 / 2.1-48
	40	1 ... 5000	10	±0.1	610	610	300	18	120	180	
	63	1 ... 5000	10	±0.1	1500	1500	600	65	340	600	
With heavy-duty guide ZR-HD											
	18	1 ... 1000	3	±0.08	60	1820	1820	70	115	112	5 / 2.1-62
	25	1 ... 1000	3	±0.1	260	5400	5600	260	415	400	
	40	1 ... 1000	3	±0.1	610	5400	5600	375	560	540	

1) Special lengths on request

Toothed belt axes DGE-ZR

Peripherals overview

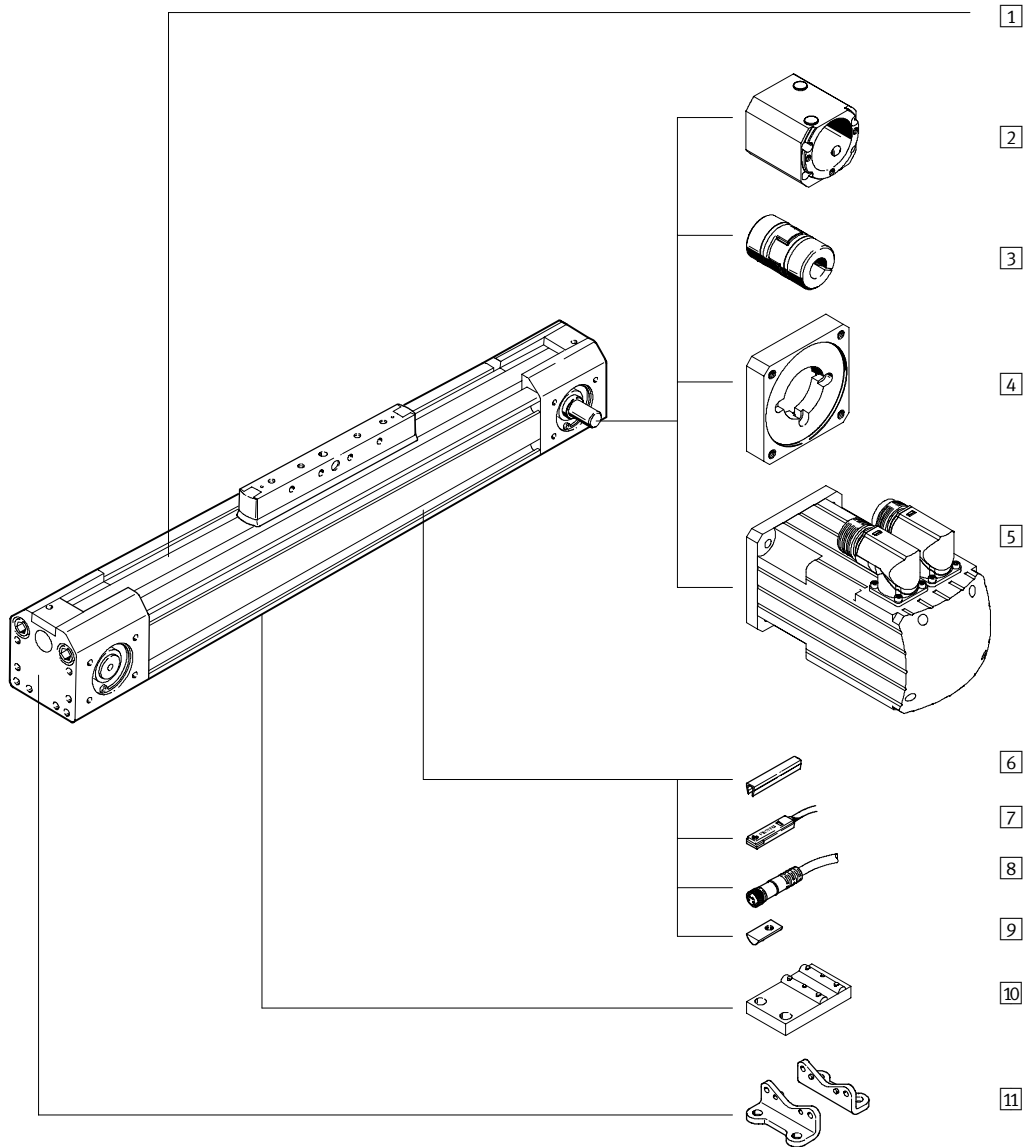

Toothed belt axes DGE-ZR

Peripherals overview

Variants and accessories		
Type	Brief description	→ Page
1	Toothed belt axis DGE-ZR	5 / 2.1-8
2	Coupling housing KG	5 / 2.1-78
3	Coupling KSE	5 / 2.1-78
4	Motor flange MTR-FL	5 / 2.1-78
5	Motor MTR	Motors specially matched to the axis, with or without gearing, with or without brake 5 / 2.1-78
6	Slot cover B/S	For protecting against the ingress of dirt 5 / 2.1-87
7	Proximity sensor G/H/I/J/N	For use as a proximity signal and safety monitoring 5 / 2.1-90
8	Plug socket with cable V	For proximity sensors 5 / 2.1-90
9	Slot nut for mounting slot Y	For mounting attachments 5 / 2.1-87
10	Central support M	For mounting the axis 5 / 2.1-82
11	Foot mounting F	For mounting the axis 5 / 2.1-81

Toothed belt axes DGE-ZR

Type code



		DGE	-	25	-	500	-	ZR	-	LK	-	RV	-	KG	-	SED	-	
Type																		
DGE	Toothed belt drive																	
Size																		
Stroke [mm]																		
Drive function																		
ZR	Toothed belt																	
Drive shaft on left																		
LK	No drive shaft on left																	
LV	Drive shaft on left, front																	
LH	Drive shaft on left, rear																	
LB	Drive shaft on left, front and rear																	
Drive shaft on right																		
RK	No drive shaft on right																	
RV	Drive shaft on right, front																	
RH	Drive shaft on right, rear																	
RB	Drive shaft on right, front and rear																	
Coupling housing																		
KG	Coupling housing																	
Motor type																		
STD	Stepper motor																	
STED	Stepper motor with integrated power electronics																	
STDP	Stepper motor for high performance																	
STG	Stepper motor with gear unit																	
SED	Servo motor																	
SEDP	Servo motor for high performance																	
SEG	Servo motor with gear unit																	
SEI	Servo motor with integrated gearing																	
SEIP	Servo motor with integrated gearing for high performance																	
Motor brake																		
BR	Brake																	

Toothed belt axes DGE-ZR

Type code

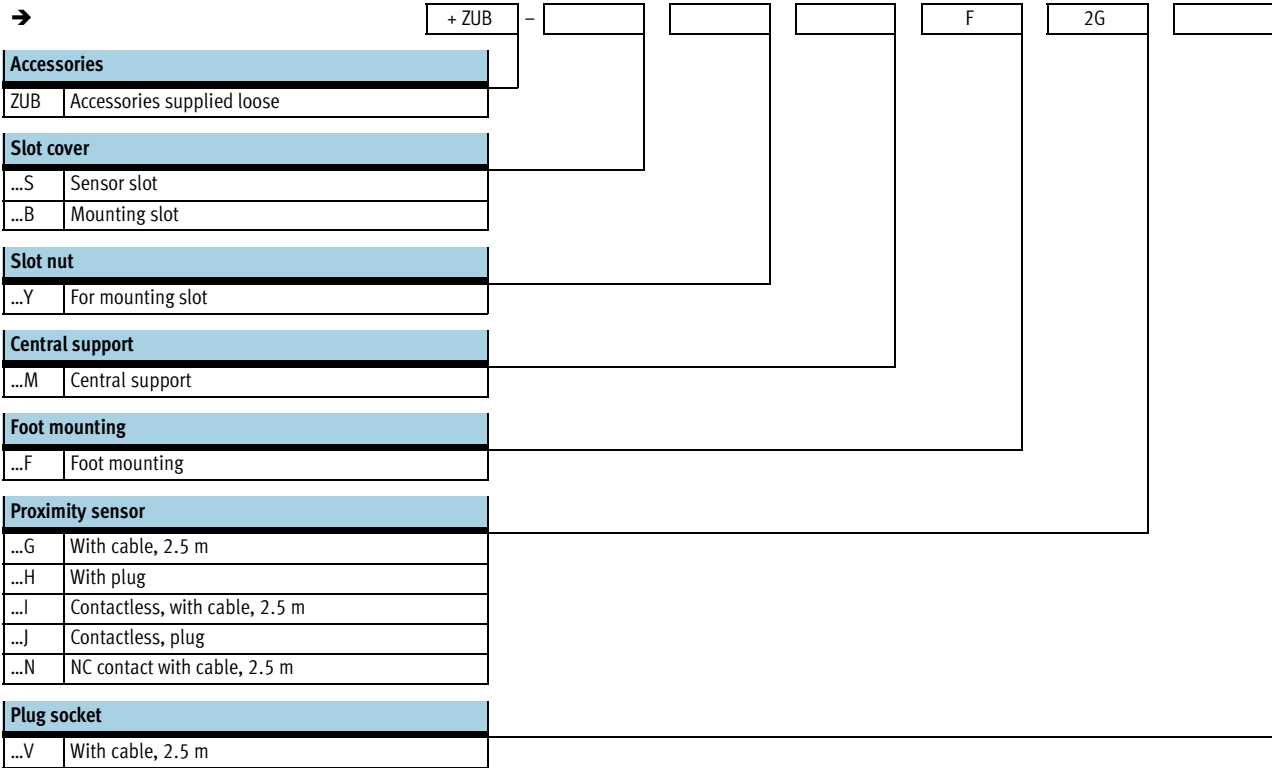

Toothed belt axes DGE-ZR

Technical data



- - Size
8 ... 63
- - Stroke length
1 ... 4500 mm

- - www.festo.com/en/Spare_parts_service



General technical data						
Size	8	12	18	25	40	63
Constructional design	Electromechanical axis with toothed belt					
Guide	-					
Mounting position	Any					
Max. working stroke ¹⁾ [mm]	1 ... 650	1 ... 1000	1 ... 1000	1 ... 3000 ²⁾	1 ... 4000 ²⁾	1 ... 4500 ²⁾
Max. working load [kg]	1.5	3	6	20	50	120
Max. feed force F _x [N]	15	30	60	260	610	1500
Max. driving torque [Nm]	0.08	0.18	0.5	2.6	9.7	42
Max. no-load driving torque ³⁾ [Nm]	0.05	0.08	0.2	0.5	1.0	4.5
Max. speed [m/s]	1	1.5	2	5	5	5
Repetition accuracy [mm]	±0.08			±0.1		

- 1) Total stroke = working stroke + 2x stroke reserve
- 2) Special lengths on request
- 3) Measured at a speed of 0.2m/s

Operating and environmental conditions						
Size	8	12	18	25	40	63
Ambient temperature [°C]	-10 ... +40					
Protection class	IP40					

Weights [kg]						
Size	8	12	18	25	40	63
Basic weight with 0 mm stroke ¹⁾	0.237	0.31	0.862	1.89	6.05	23.2
Additional weight per 100 mm stroke	0.05	0.08	0.16	0.32	0.51	1.8
Moving load	0,012	0,02	0,055	0,28	0,60	1,80

- 1) Including coupling housing

Mass moment of inertia						
Size	8	12	18	25	40	63
J ₀ [kg cm ²]	0.006	0.015	0.064	0.38	2.34	25.6
J _H per metre stroke [kg cm ² /m]	0.003	0.009	0.021	0.078	0.45	3.6
J _L per kg working load [kg cm ² /kg]	0.259	0.365	0.685	1	2.53	7.85

The mass moment of inertia J_A of the entire axis is calculated as follows:

$$J_A = J_0 + J_H \times \text{working stroke [m]} + J_L \times m_{\text{working load [kg]}}$$

Toothed belt axes DGE-ZR

Technical data

Toothed belt							
Size		8	12	18	25	40	63
Tensile stress ¹⁾	[%]	0.04	0.1	0.2	0.11	0.1	0.15
Pitch	[mm]	2	2	2	3	5	8
Effective radius; effective diameter	[mm]	10.18	12.09	16.55	20.05	31.83	56.02
Feed constant	[mm/rev.]	32	38	52	63	100	176

1) At max. feed force

Materials

Sectional view

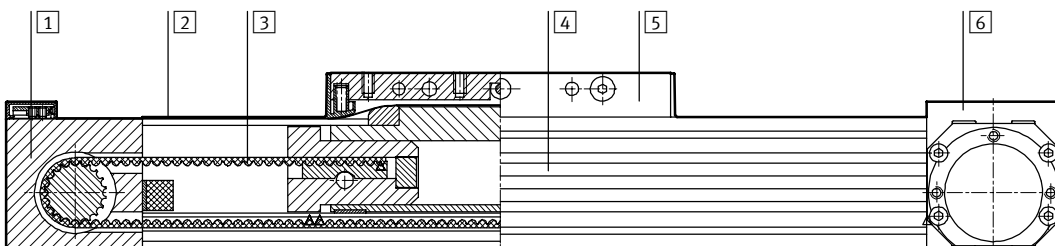

Axis		
1	Return pulley housing	Anodised aluminium
2	Cover strip	Corrosion resistant steel
3	Toothed belt	Polychloroprene with Glascord and nylon coating
4	Profile	Anodised aluminium
5	Slide	Anodised aluminium
6	Drive housing	Anodised aluminium

Stroke reserve

L12 The stroke reserve is a safety distance available on both sides of the axis in addition to the stroke.

L11 Internal mechanical stop

L1+ Overall length of axis

1 Working stroke

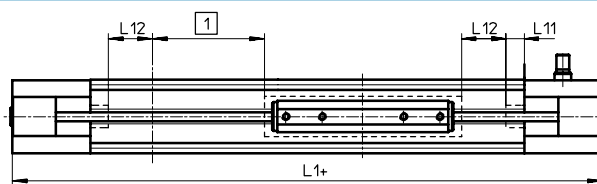

Example:

Type DGE-25-500-ZR

Working stroke = 500 mm

Stroke reserve = (2x 63 mm)
= 126 mm

Total stroke = 500 mm + 126 mm
= 626 mm

Size		8	12	18	25	40	63
L12 per end position	[mm]	27.5	36.5	46.5	63	100	172

Toothed belt axes DGE-ZR

Technical data



Characteristic load values

The indicated forces and torques refer to the centre line of the internal diameter of the profile.

They must not be exceeded in the dynamic range. Special attention must be paid to the cushioning phase.

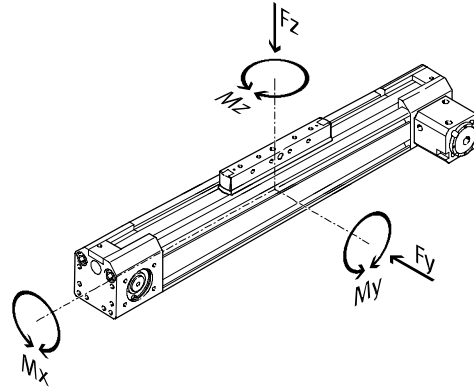

If the drive is subjected to more than two of the indicated forces and torques simultaneously, the following equations must be satisfied in addition to the indicated maximum loads.

$$0.4 \times \frac{F_z}{F_{z_{max}}} + \frac{M_x}{M_{x_{max}}} + \frac{M_y}{M_{y_{max}}} + 0.2 \times \frac{M_z}{M_{z_{max}}} \leq 1$$

$$\frac{F_z}{F_{z_{max}}} \leq 1 \quad \frac{M_z}{M_{z_{max}}} \leq 1$$

Permissible forces and torques

Size		8	12	18	25	40	63
F _y _{max.}	[N]	–	–	–	–	–	–
F _z _{max.}	[N]	38	59	120	330	800	1600
M _x _{max.}	[Nm]	0.15	0.3	0.5	1	4	8
M _y _{max.}	[Nm]	2	4	11	20	60	120
M _z _{max.}	[Nm]	0.3	0.5	1	3	8	24

2nd moment of area

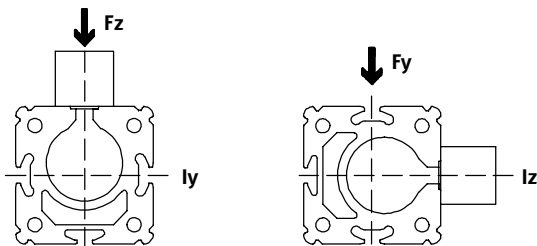

Size		8	12	18	25	40	63
I _y	[mm ⁴]	6.6x10 ³	19.7x10 ³	69.8x10 ³	224x10 ³	673x10 ³	5688x10 ³
I _z	[mm ⁴]	6.7x10 ³	19.1x10 ³	72.3x10 ³	240x10 ³	748x10 ³	6031x10 ³



Design tool

PtTool

www.festo.com/en/engineering

Toothed belt axes DGE-ZR

Technical data

Maximum permissible support span l as a function of the force F

The drive may need to be supported with central supports MUP in order to restrict deflection with long stroke lengths. The following diagrams serve to determine the maximum permissible support span l as a function of the force acting upon the drive F .

1 Force on the surface of the slide

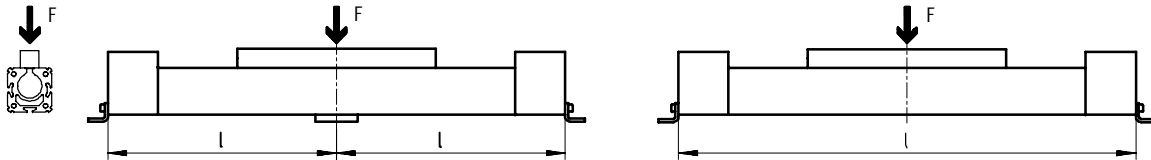

2 Force on the front of the slide

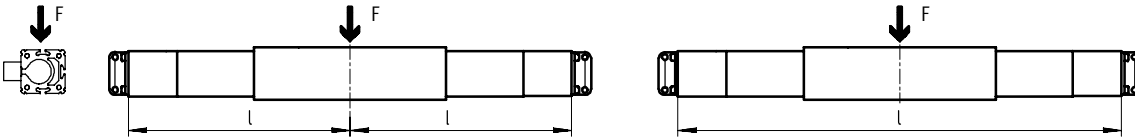

Maximum permissible support span l (without central support) as a function of the force F

DGE-8

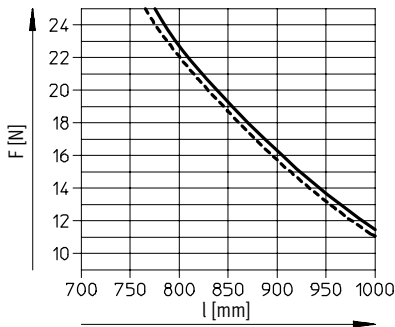

DGE-12

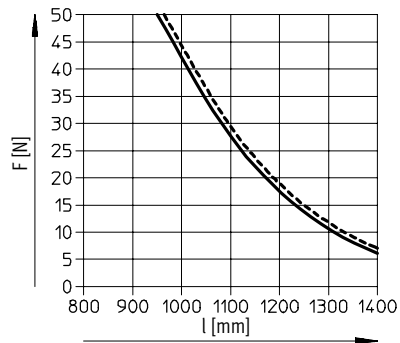

DGE-18

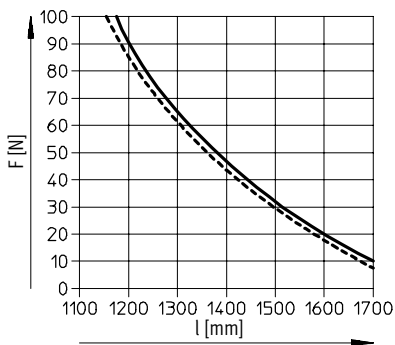

DGE-25

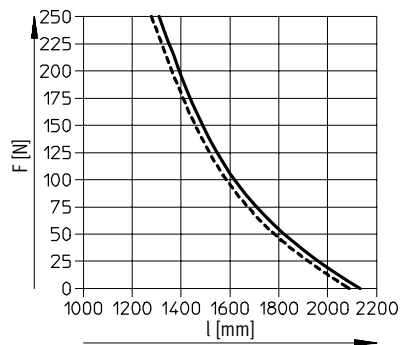

Toothed belt axes DGE-ZR

Technical data



Maximum permissible support span l (without central support) as a function of the force F

DGE-40

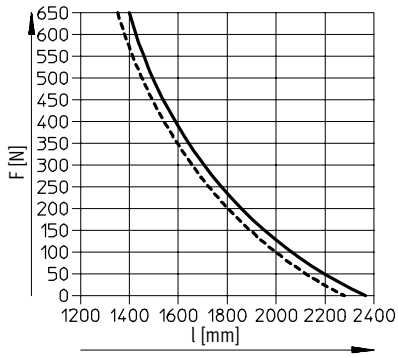

DGE-63

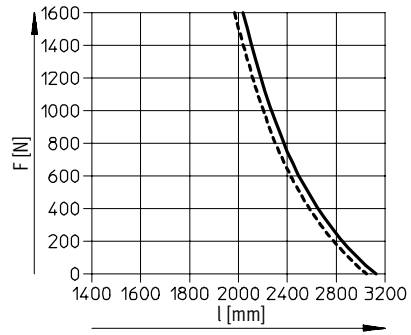

- 1
- - - 2

Toothed belt axes DGE-ZR

Technical data

Maximum permissible acceleration a as a function of the effective load m

DGE-8

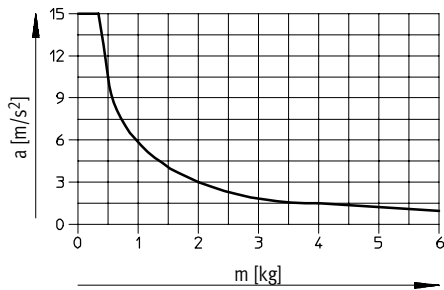

DGE-12

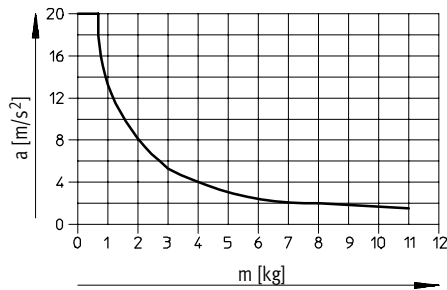

DGE-18

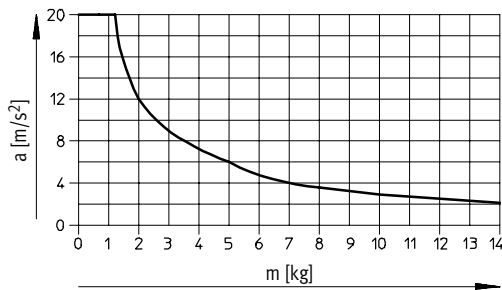

DGE-25

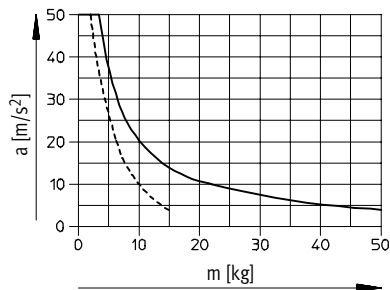

DGE-40

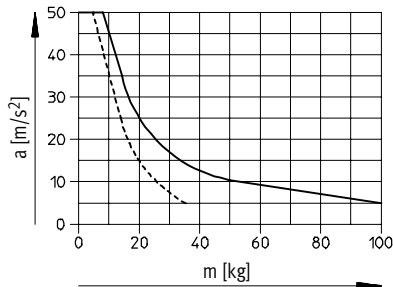

DGE-63

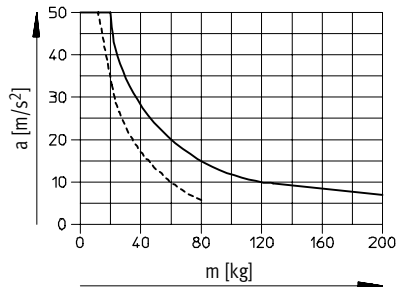

- - - vertical
 — horizontal

Toothed belt axes DGE-ZR

Technical data



Dimensions

Download CAD data → www.festo.com/en/engineering

Size 8 ... 18

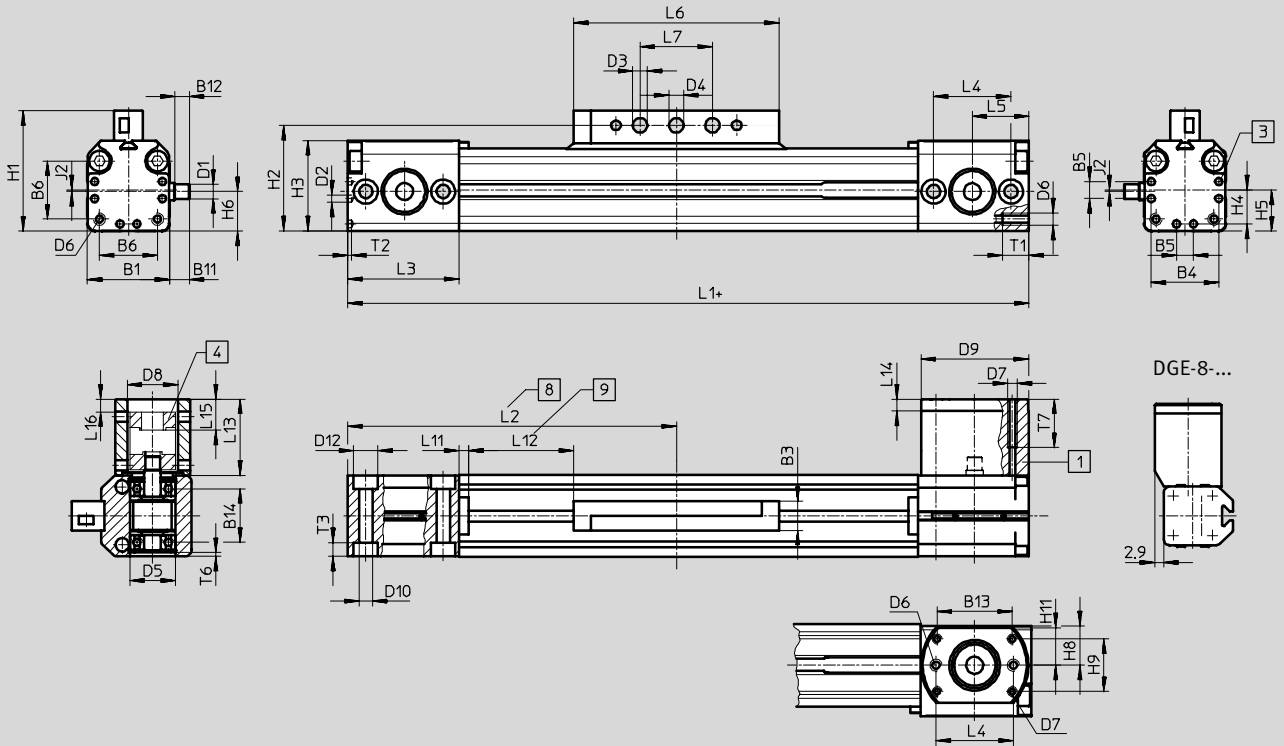

- 1 Coupling housing
- 2 Centring hole for foot mounting
- 3 Coupling
- 4 Slide in end position of the working stroke (including L12)
- 5 Recommended stroke reserve + = plus stroke length

Profile

Size 8

Size 12

Size 18

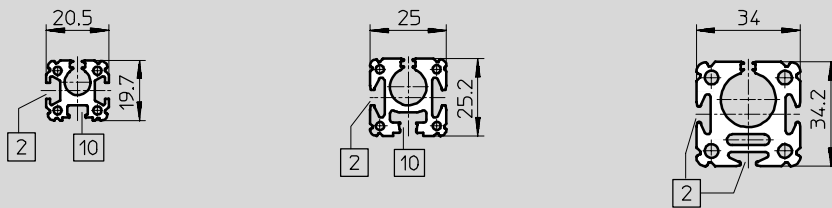

- 2 Sensor slot for proximity sensor
- 10 Not suitable for proximity sensor

Toothed belt axes DGE-ZR



Technical data

Size	B1 +0.2	B3 ±0.1	B4	B5	B6	B11	B12	B13	B14	D1 ∅ g6	D2 ∅	D3 ∅ H11	D4 ∅ H7	D5 ∅	D6	D7
8	20.5	8	16	4	13	7.3	5	–	12	4	2	3.4	4	12	M3	M3
12	25	8	21	6	18.6	8.7	6.5	22.7	16.2	4	2	3.4	4	16	M3	M3
18	34	12	28	7	24	7.7	5.5	31.1	22	6	3	5.4	6	19	M5	M4

Size	D8 ∅	D9 ∅ g7	D10	D12	H1	H2	H3	H4	H5	H6	H8	H9	H11	J2	L1	L2
8	17	28.7	3.4	M4	30	26.5	23.1	8	9.8	8.1	11	0	11	1.7	180	90
12	19	30	3.4	M4	35.5	32	28.6	10.5	12.5	11.8	11	13.1	11	0.7	216	108
18	25	44	5.5	M5	49.8	43.8	37.6	14	17	16.4	15.5	21.8	15.5	0.6	282	141

Size	L3	L4 ±0.1	L5	L6 +4	L7 ±0.1	L11 ±0.1	L12	L13	L14	L15	L16	T1	T2	T3	T6	T7
8	30	21	15.5	52	15	4	27.5	27.5	5	9.7	3.2	7	1.1	3.4	0.7	18.8
12	33	24	17	64	15	4	36.5	29	5	11.3	4.8	7	1.1	3.4	0.8	29
18	46	32	23.5	85	30	4	46.5	31.5	5	12.8	5.3	11	1.6	5.7	1.5	19

Toothed belt axes DGE-ZR

Technical data



Dimensions

Download CAD data → www.festo.com/en/engineering

Size 25 ... 63

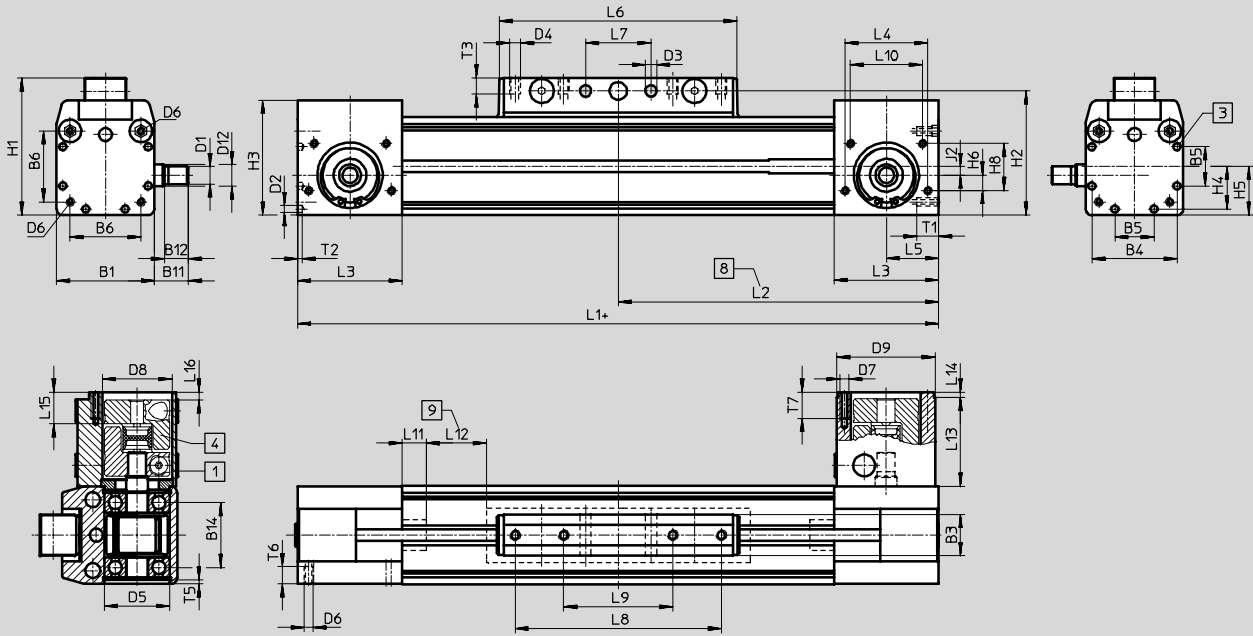

Size 63

Size 25/40

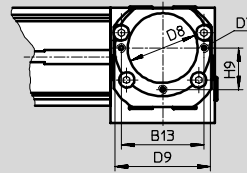
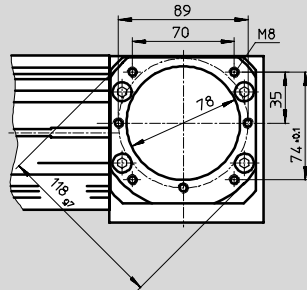

- 1 Coupling housing
- 3 Centring hole for foot mounting HP
- 4 Coupling
- 8 Applies to end positions where stroke reserve is maintained up to the mechanical stop
- 9 Stroke reserve (available safety distance from mechanical end position at both ends)
- + = plus stroke length

Profile

Size 25

Size 40

Size 63

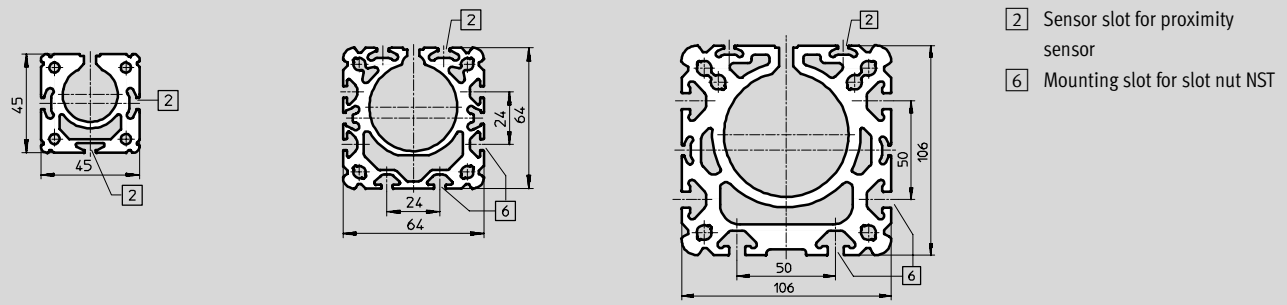

- 2 Sensor slot for proximity sensor
- 6 Mounting slot for slot nut NST

Toothed belt axes DGE-ZR

Technical data

Size	B1	B3 +0.2	B4	B5	B6	B11	B12	B13	B14	D1 ∅ h6	D2 ∅	D3 ∅ +0.2	D4
25	45	19	39.1	18	32.5	15.5	11	38	29.8	8	3.3	5.2	M5
40	64	21	53	28	49	30	24.5	56	43.5	15	4.3	6.5	M6
63	106	24	89	44	83	41	35	-	77.7	25	6.3	8.5	M8

Size	D5 ∅ H7	D6	D7	D8 ∅	D9 ∅ g7	D12 ∅	H1	H2	H3	H4	H5	H6	H8
25	30	M4	M4	32	44	10	63	57	52.8	19.6	22.5	7	21.6
40	40	M5	M6	48	64	17	86	78	71.8	26.5	32	11.5	31
63	62	M8	M8	78	-	31	131	122	115	44.5	53	21.5	49

Size	H9 ±0.1	J2	L1	L2	L3	L4	L5	L6	L7 ±0.1	L8 ±0.1	L9 ±0.1	L10
25	19	4.1	372	186	48	38	24	109	30	-	50	33
40	28	5	569	284.5	67	54	34	171	70	130	40	54
63	35	6.5	882	441	106	84	55	234	110	190	70	84

Size	L11	L12	L13	L14	L15	L16 ¹⁾	T1	T2	T3	T5	T6	T7
25	11	63	40	3.2	14.6	3.6	10	2	7.5	1.4	8	10
40	15	100	65	4	22.8	-2.2	12	3	10.5	1.9	10	13
63	15	172	91	5	35	0	21	4	12.5	4.5	15	16

1) Negative dimension: Protrudes above coupling housing

Toothed belt axes DGE-ZR

Ordering data – Modular products



Order code

Mandatory data

- LK No drive shaft on left
- LV Drive shaft on left, front
- LH Drive shaft on left, rear
- LB Drive shaft on left, front and rear
- RK No drive shaft on right
- RV Drive shaft on right, front
- RH Drive shaft on right, rear
- RB Drive shaft on right, front and rear

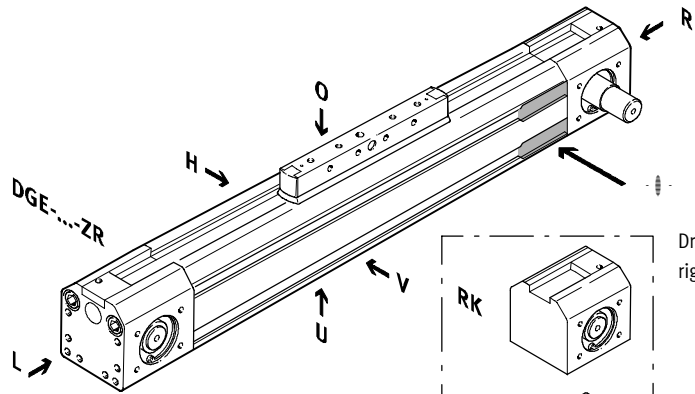

Drive shaft left

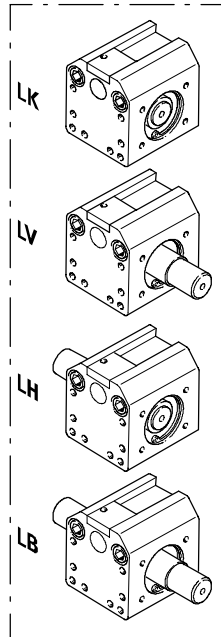

Drive shaft right

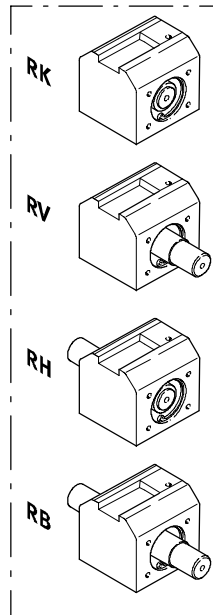

- Note

The insertion point for the proximity sensor is located on the right side of the toothed belt axis DGE-ZR

- O top
- U underneath
- R right
- L left
- V front
- H rear

Toothed belt axes DGE-ZR

Ordering data – Modular products



Order code

Options

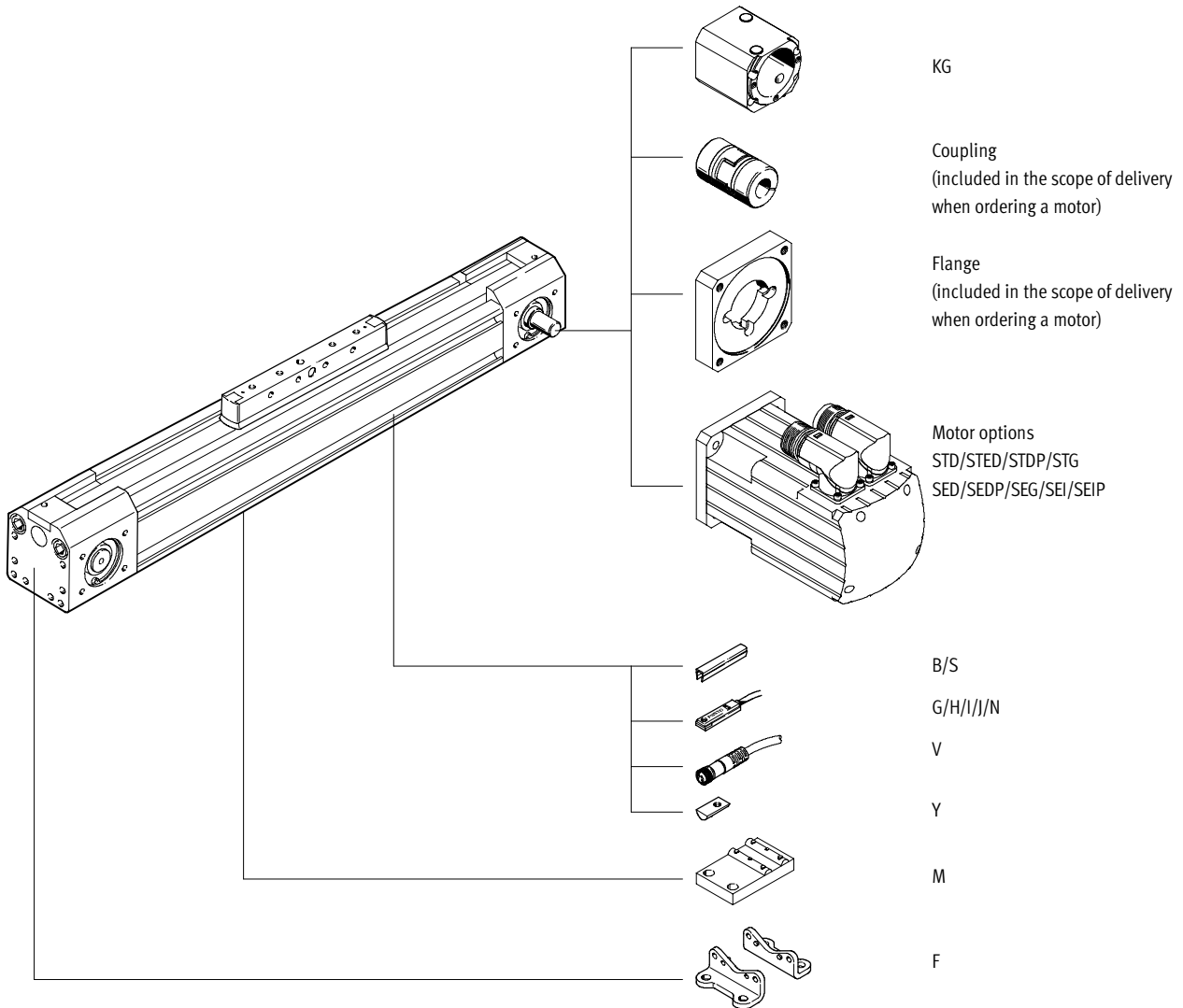

Toothed belt axes DGE-ZR

Ordering data – Modular products



M Mandatory data							O Options →
Module No.	Design	Size	Stroke	Drive function	Drive shaft on left	Drive shaft on right	Coupling housing
193 739	DGE	8	1 ... 4 500	ZR	LK LV LH LB	RK RV RH RB	KG
193 740							
193 741							
193 742							
193 743							
193 744							
Ordering example							
193 742	DGE	- 25	- 500	- ZR	- LK	- RV	- KG

Ordering table											
Size	8	12	18	25	40	63	Condi- tions	Code	Enter code		
M Module No.	193 739	193 740	193 741	193 742	193 743	193 744					
Design	Electromechanical linear axis								DGE	DGE	
Size	8	12	18	25	40	63		-...			
Stroke [mm]	1 ... 650	1 ... 1000		1 ... 3000	1 ... 4000	1 ... 4500	1	-...			
Drive function	Electromechanical drive with toothed belt								-ZR	-ZR	
Drive shaft on left	No drive shaft on left							2	-LK		
	Drive shaft on left, front								-LV		
	Drive shaft on left, rear								-LH		
	Drive shaft on left, front and rear								-LB		
Drive shaft on right	No drive shaft on right							3	-RK		
	Drive shaft on right, front								-RV		
	Drive shaft on right, rear								-RH		
	Drive shaft on right, front and rear								-RB		
O Coupling housing	Coupling housing								-KG		

- 1 **Stroke** Special stroke lengths on request.
- 2 **LK** Not with drive shaft on right RK.

- 3 **RK** Not with drive shaft on left LK.

Transfer order code

	DGE	-		-	ZR	-		-	
--	-----	---	--	---	----	---	--	---	--

Toothed belt axes DGE-ZR

Ordering data – Modular products

Options	
Motor type STD STED STDP STG SED SEDP SEG SEI SEIP - SEG	Brake BR - BR

Ordering table										
Size	8	12	18	25	40	63	Condi- tions	Code	Enter code	
↓ Motor type Stepper motor [0]	Stepper motor					-	-	[4]	-STD	
	with integrated power electronics			-	-	-	-	[4]	-STED	
	-	-	-	for high performance	-	-	[4]	-STDP		
	-	-	-	-	with gear unit	-	[4]	-STG		
	Servo motor		Servo motor				-	[4]	-SED	
	-	for high performance	-	-	for high performance	-	[4]	-SEDP		
	-	-	-	with gear unit	-	-	[4]	-SEG		
	-	-	-	-	with integrated gearing	-	[4]	-SEI		
-	-	-	-	with inte- grated gear- ing for high performance	-	[4]	-SEIP			
↓ Brake	Motor brake						[5]	-BR		

[4] **Motor type** Only with coupling housing KG.

[5] **BR** Only permissible with motor type.

Allocation of order codes to motor types
 → from 5 / 2.1-78
 The motor controller and cable set must be ordered separately.
 Stepper motor → 5 / 2.2-2
 Servo motor → 5 / 2.2-16

Transfer order code

-		-	
---	--	---	--

Toothed belt axes DGE-ZR

Ordering data – Modular products



2.1

Options						
Accessories	Slot cover	Slot nut	Central support	Foot mounting	Proximity sensor	Plug socket
ZUB	...S ...B	...Y	...M	...F	...G ...H ...I ...J ...N	...V
ZUB	- 2S	10Y		F	2G	2V

Ordering table												
Size			8	12	18	25	40	63	Condi- tions	Code	Enter code	
↓ Accessories			Supplied separately							ZUB-	ZUB-	
○ Slot cover	Sensor slot		1 ... 10								...S	
	Mounting slot		-	-	-	-	1 ... 10				...B	
Slot nut	for mounting slot		-	-	1 ... 10						...Y	
Central support			1 ... 10								...M	
Foot mounting (kit)			1 ... 10								...F	
Proximity sensor	with cable 2.5 m		1 ... 10								...G	
	with plug		1 ... 10								...H	
	contactless with cable 2.5 m		1 ... 10								...I	
	contactless, plug		1 ... 10								...J	
	NC contact with cable 2.5 m		1 ... 10								...N	
Plug socket	with cable 2.5 m		1 ... 10								...V	

Transfer order code

ZUB - - - - - -

Toothed belt axes DGE-ZR

Application example

FESTO

Planar surface gantry

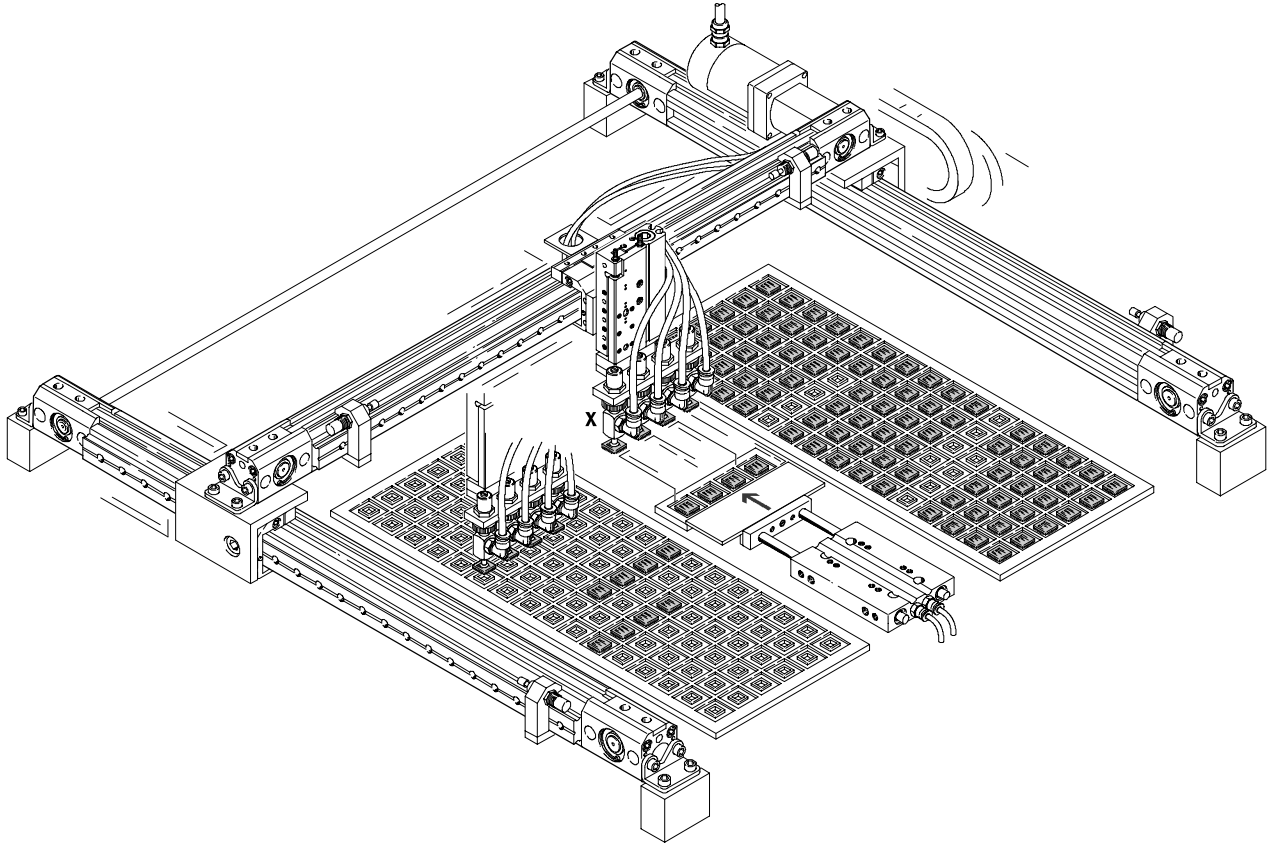

Toothed belt axes DGE-ZR-KF, with recirculating ball bearing guide

Peripherals overview



Electrical positioning systems
Electromechanical drives

2.1

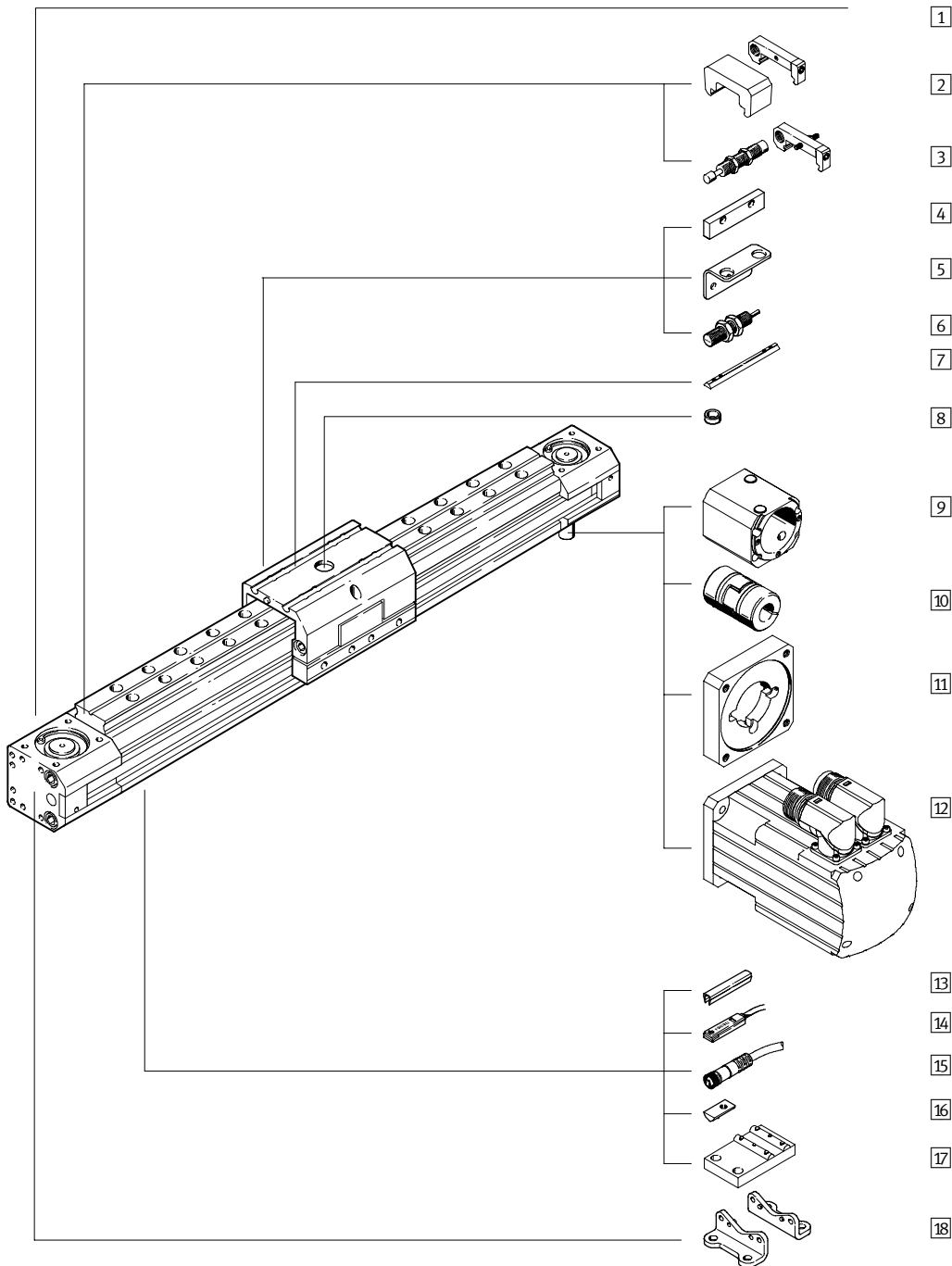

Toothed belt axes DGE-ZR-KF, with recirculating ball bearing guide

Peripherals overview

Variants and accessories					
Type	Brief description	GK/GV	GA	→ Page	
1	Toothed belt axis DGE-ZR-KF	■	■	5 / 2.1-28	
2	Emergency buffer with retainer ¹⁾ A	■	■	5 / 2.1-85	
3	Shock absorber kits C	■	-	5 / 2.1-84	
3	Shock absorber kits E	-	■	5 / 2.1-85	
4	Switching lug L	■	-	5 / 2.1-88	
5	Sensor bracket T	■	-	5 / 2.1-88	
6	Inductive proximity sensor O/P/R/W	■	-	5 / 2.1-90	
7	Slot nut for slide X	■	■	5 / 2.1-87	
8	Centring pins/sleeves Z	■	■	5 / 2.1-87	
9	Coupling housing KG	■	■	5 / 2.1-78	
10	Coupling KSE	■	■	5 / 2.1-78	
11	Motor flange MTR-FL	■	■	5 / 2.1-78	
12	Motor MTR	■	■	5 / 2.1-78	
13	Slot cover B/S	■	■	5 / 2.1-87	
14	Proximity sensor G/H/I/J/N	■	■	5 / 2.1-90	
15	Plug socket with cable V	■	■	5 / 2.1-90	
16	Slot nut for mounting slot Y	■	■	5 / 2.1-87	
17	Central support M	■	■	5 / 2.1-82	
18	Foot mounting F	■	■	5 / 2.1-81	

1) Fitted as standard for GV and GA

Toothed belt axes DGE-ZR-KF, with recirculating ball bearing guide

Type code



		DGE	-	25	-	500	-	ZR	-	LK	-	RV	-	KG	-	KF	-	GK	-	KL	-	SED	-	
Type																								
DGE	Toothed belt drive																							
Size																								
Stroke [mm]																								
Drive function																								
ZR	Toothed belt																							
Drive shaft on left																								
LK	No drive shaft on left																							
LV	Drive shaft on left, front																							
LH	Drive shaft on left, rear																							
LB	Drive shaft on left, front and rear																							
Drive shaft on right																								
RK	No drive shaft on right																							
RV	Drive shaft on right, front																							
RH	Drive shaft on right, rear																							
RB	Drive shaft on right, front and rear																							
Coupling housing																								
KG	Coupling housing																							
Guide																								
KF	Recirculating ball bearing guide																							
Slide																								
GK	Standard slide																							
GV	Extended slide																							
GA	Protected version																							
Additional slide																								
KL	Left																							
KR	Right																							
Motor type																								
STD	Stepper motor																							
STED	Stepper motor with integrated power electronics																							
STDP	Stepper motor for high performance																							
STG	Stepper motor with gear unit																							
SED	Servo motor																							
SEG	Servo motor with gear unit																							
SEGP	Servo motor with gear unit for high performance																							
SEI	Servo motor with integrated gearing																							
SEIP	Servo motor with integrated gearing for high performance																							
Motor brake																								
BR	Brake																							

Toothed belt axes DGE-ZR-KF, with recirculating ball bearing guide

Type code

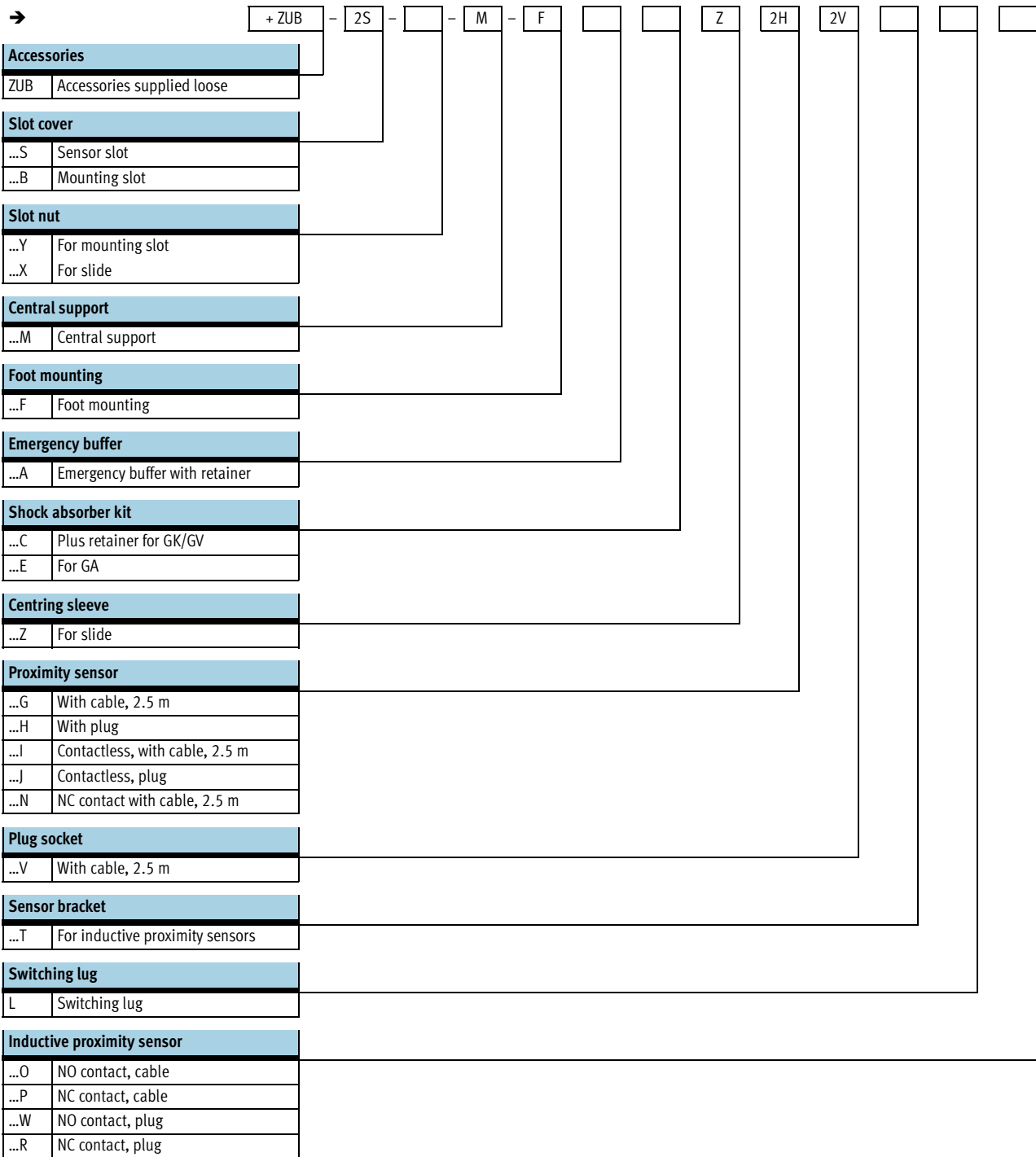

Toothed belt axes DGE-ZR-KF, with recirculating ball bearing guide

Technical data



- - Size
8 ... 63
- - Stroke length
1 ... 4500 mm

- - www.festo.com/en/Spare_parts_service

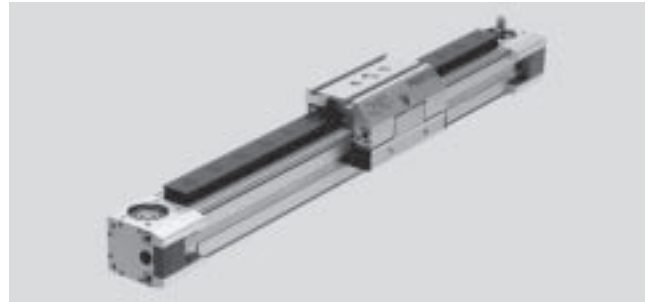

General technical data								
Size		8	12	18	25	40	63	
Constructional design		Electromechanical axis with toothed belt and recirculating ball bearing guide						
Guide		Recirculating ball bearing guide						
Mounting position		Any						
Max. working stroke ¹⁾	GK [mm]	1 ... 650	1 ... 1000	1 ... 1000	1 ... 3000 ²⁾	1 ... 4000 ²⁾	1 ... 4500 ²⁾	
	GV [mm]	–	–	1 ... 920	1 ... 2900	1 ... 3830	1 ... 4250	
	GA [mm]	–	–	–	1 ... 1800	1 ... 1800	–	
Max. working load		[kg]	1.5	3	6	20	50	120
Max. feed force F_x		[N]	15	30	60	260	610	1500
Max. driving torque		[Nm]	0.08	0.18	0.5	2.6	9.7	42
Max. no-load driving torque ³⁾		[Nm]	0.05	0.08	0.2	0.5	1.0	4.5
Max. speed		[m/s]	1	1.5	2	3	3	3
Repetition accuracy		[mm]	±0.08			±0.1		

- 1) Total stroke = working stroke + 2x stroke reserve
- 2) Special lengths on request
- 3) Measured at a speed of 0.2 m/s

Operating and environmental conditions							
Size		8	12	18	25	40	63
Ambient temperature		[°C]	–10 ... +40				
Protection class			IP40				

Weights [kg]								
Size		8	12	18	25	40	63	
Basic weight with 0 mm stroke ¹⁾	GK	0.32	0.66	1.16	2.6	7.6	30.3	
	GV	–	–	1.62	3.52	9.52	40.2	
	GA	–	–	–	3.51	9.67	–	
Additional weight per 100 mm stroke	GK/GV	0.095	0.14	0.26	0.47	0.94	2.6	
	GA	–	–	–	0.56	1.06	–	
Moving load	GK	0,085	0,14	0,32	0,71	1,8	5	
	GV	–	–	0,48	0,97	2,52	7,46	
	GA	–	–	–	1,27	3,17	–	
Additional slide		KL/KR	–	–	0.25	0.38	1.06	3.1

- 1) Including coupling housing and slide

Toothed belt axes DGE-ZR-KF, with recirculating ball bearing guide

Technical data

Mass moment of inertia		8	12	18	25	40	63
J ₀	GK [kg cm ²]	0.025	0.058	0.247	0.81	5.25	50.7
	GV [kg cm ²]	–	–	0.355	1.08	7.14	70.9
	GA [kg cm ²]	–	–	–	1.37	8.71	–
J _H per metre stroke	[kg cm ² /m]	0.003	0.009	0.021	0.078	0.45	3.6
J _L per kg working load	[kg cm ² /kg]	0.259	0.365	0.685	1	2.53	7.85

The mass moment of inertia J_A of the entire axis is calculated as follows:

$$J_A = J_0 + J_H \times \text{working stroke [m]} + J_L \times m_{\text{working load [kg]}}$$

Toothed belt		8	12	18	25	40	63
Tensile stress ¹⁾	[%]	0.04	0.1	0.2	0.11	0.1	0.15
Pitch	[mm]	2	2	2	3	5	8
Effective radius; effective diameter	[mm]	10.18	12.09	16.55	20.05	31.83	56.02
Feed constant	[mm/rev.]	32	38	52	63	100	176

1) At max. feed force

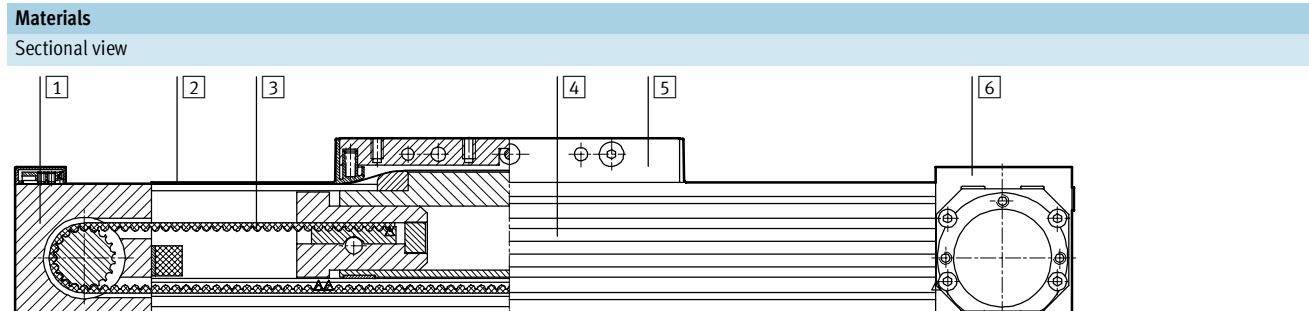

Axis		
1	Return pulley housing	Anodised aluminium
2	Cover strip	Corrosion resistant steel
3	Toothed belt	Polychloroprene with Glascord and nylon coating
4	Profile	Anodised aluminium
5	Slide	Anodised aluminium
6	Drive housing	Anodised aluminium

Toothed belt axes DGE-ZR-KF, with recirculating ball bearing guide

Technical data



Characteristic load values for axis with standard slide GK or protected version GA

The indicated forces and torques refer to the centre of the guide rail. They must not be exceeded in the dynamic range. Special attention must be paid to the cushioning phase.

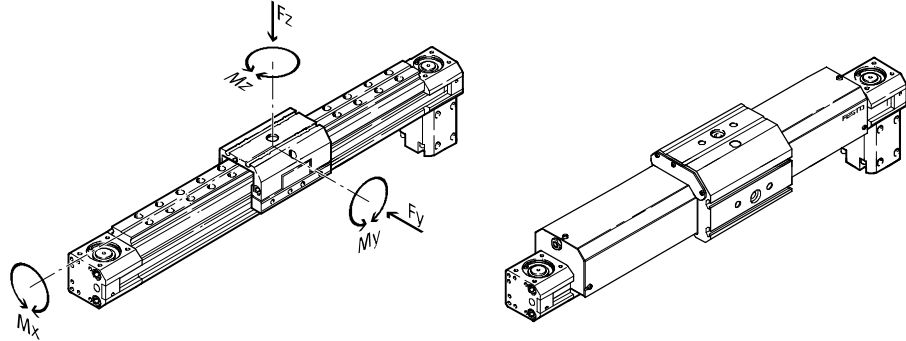

If the axis is subjected to more than two of the indicated forces and torques simultaneously, the following equations must be satisfied in addition to the indicated maximum loads.

$$\frac{F_y}{F_{y_{max}}} + \frac{F_z}{F_{z_{max}}} + \frac{M_x}{M_{x_{max}}} + \frac{M_y}{M_{y_{max}}} + \frac{M_z}{M_{z_{max}}} \leq 1$$

Permissible forces and torques		8	12	18	25	40	63
F _y _{max.}	[N]	255	565	930	3080	7300	14050
F _z _{max.}	[N]	255	565	930	3080	7300	14050
M _x _{max.}	[Nm]	1	3	7	45	170	580
M _y _{max.}	[Nm]	3.5	9	23	85	330	910
M _z _{max.}	[Nm]	3.5	9	23	85	330	910

2nd moment of area

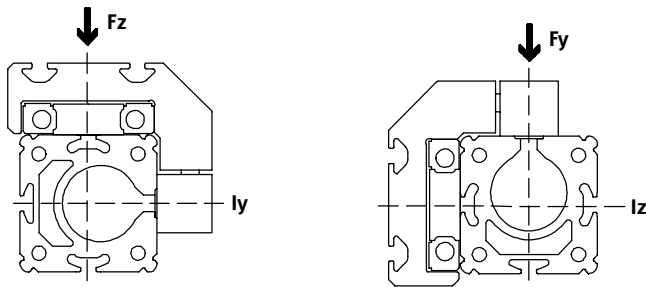

Size		8	12	18	25	40	63
l _y	[mm ⁴]	16.9x10 ³	46x10 ³	172x10 ³	551x10 ³	1908x10 ³	13677x10 ³
l _z	[mm ⁴]	7x10 ³	21x10 ³	73.7x10 ³	250x10 ³	875x10 ³	6987x10 ³



 Design tool
 PtTool
www.festo.com/en/engineering

Toothed belt axes DGE-ZR-KF, with recirculating ball bearing guide

Technical data

Characteristic load values for axis with extended slide GV

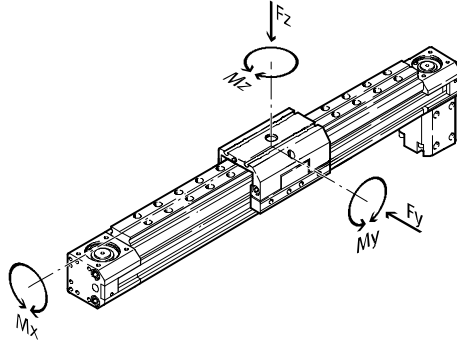
The indicated forces and torques refer to the centre of the guide rail. They must not be exceeded in the dynamic range. Special attention must be paid to the cushioning phase.



If the axis is subjected to more than two of the indicated forces and torques simultaneously, the following equations must be satisfied in addition to the indicated maximum loads.

$$\frac{F_y}{F_{y_{max}}} + \frac{F_z}{F_{z_{max}}} + \frac{M_x}{M_{x_{max}}} + \frac{M_y}{M_{y_{max}}} + \frac{M_z}{M_{z_{max}}} \leq 1$$

Permissible forces and torques							
Size		8	12	18	25	40	63
F _{y_{max.}}	[N]	255	565	930	3080	7300	14050
F _{z_{max.}}	[N]	255	565	930	3080	7300	14050
M _{x_{max.}}	[Nm]	1	3	7	45	170	580
M _{y_{max.}}	[Nm]	-	-	45	170	660	1820
M _{z_{max.}}	[Nm]	-	-	45	170	660	1820

2nd moment of area

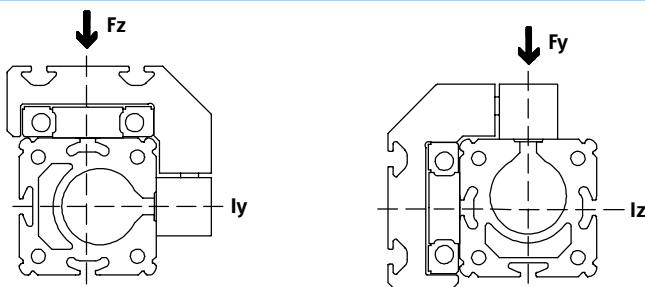

Size		8	12	18	25	40	63
l _y	[mm ⁴]	16.9x10 ³	46x10 ³	172x10 ³	551x10 ³	1908x10 ³	13677x10 ³
l _z	[mm ⁴]	7x10 ³	21x10 ³	73.7x10 ³	250x10 ³	875x10 ³	6987x10 ³

Toothed belt axes DGE-ZR-KF, with recirculating ball bearing guide

Technical data



Stroke reserve

L12 The stroke reserve is a safety distance available on both sides of the axis in addition to the stroke.

L17 Slide length

L11 Internal mechanical stop

L1+ Overall length of axis

1 Working stroke

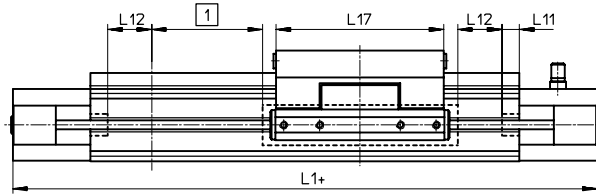

Example:

Type DGE-25-500-ZR

Working stroke = 500 mm

Stroke reserve = (2x 63 mm)

= 126 mm

Total stroke = 500 mm + 126 mm

= 626 mm

Size	8	12	18	25	40	63
L12 per end position [mm]	27.5	36.5	46.5	63	100	172

Working stroke reduction with standard slide GK or extended slide GV and additional slide KL/KR

L17 = Slide/additional slide length

L18 = Distance between both slides

4 Additional slide

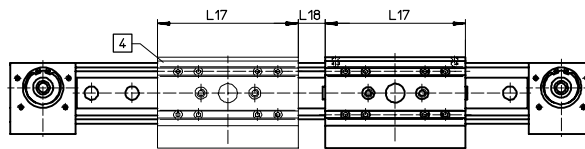

For a toothed belt axis with additional slide, the working stroke is reduced by the length of the additional slide and the distance between both slides.

Example:

Type DGE-25-500-ZR-...-KF-GK-KL

Working stroke without

additional slide = 500 mm

L18 = 20 mm

L17 = 105 mm

Working stroke with

additional slide = 375 mm

(500 mm – 20 mm – 105 mm)

Toothed belt axes DGE-ZR-KF, with recirculating ball bearing guide

Technical data

Maximum permissible support span l as a function of the force F

The axis may need to be supported with central supports MUP in order to restrict deflection with long stroke lengths. The following diagrams serve to determine the maximum permissible support span l as a function of the force acting upon the axis F .

1 Force on the surface of the slide

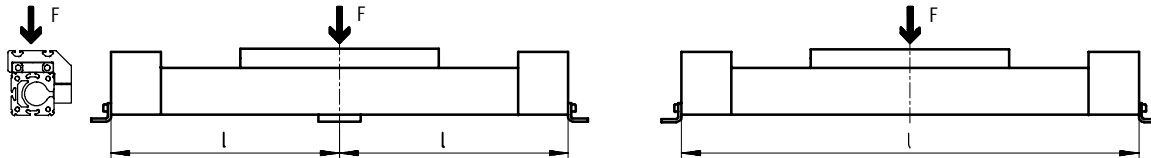

2 Force on the front of the slide

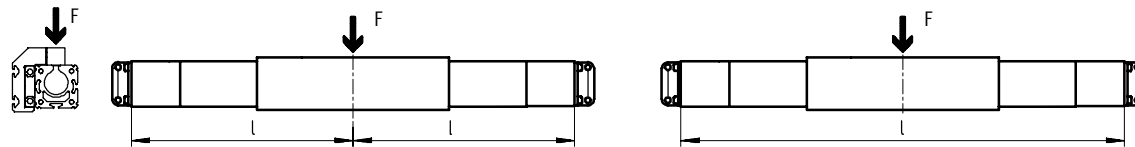

Maximum support span l (without central support) as a function of the force F

DGE-8

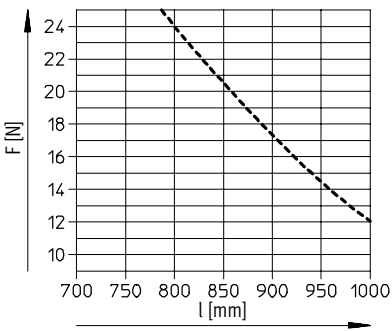

DGE-12

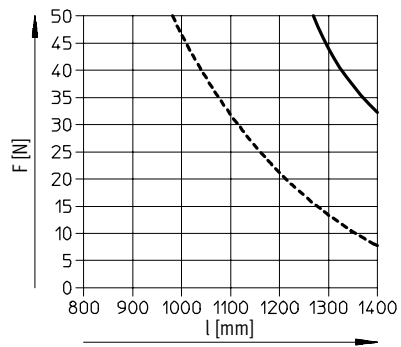

DGE-18

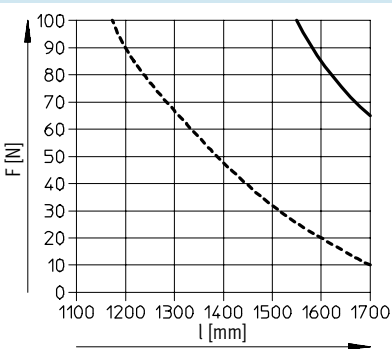

DGE-25

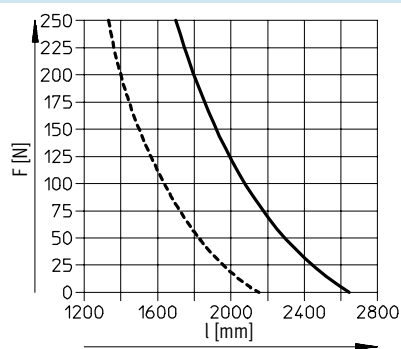

- 1
- - - 2

Toothed belt axes DGE-ZR-KF, with recirculating ball bearing guide

Technical data



Maximum support span l (without central support) as a function of the force F

DGE-40

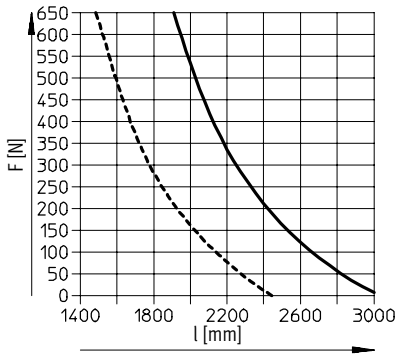

DGE-63

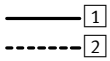
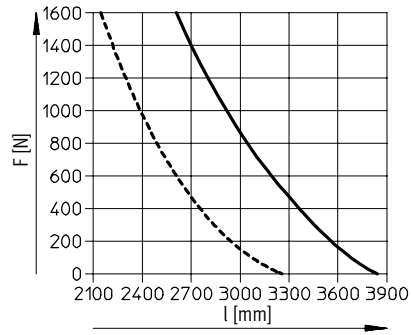

Maximum permissible acceleration a as a function of the effective load m

DGE-8

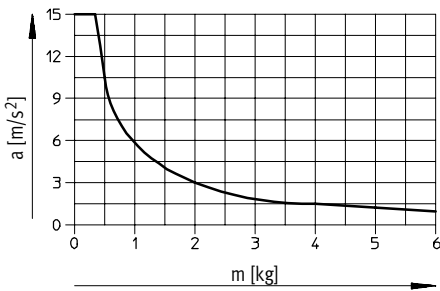

DGE-12

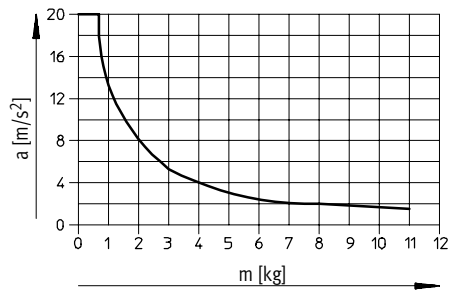

DGE-18

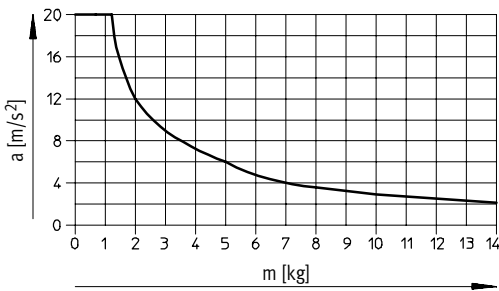

DGE-25

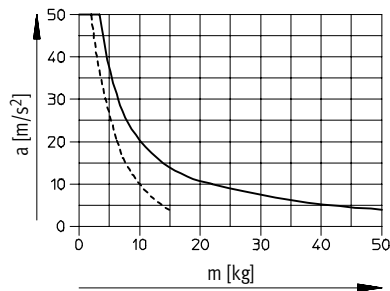

DGE-40

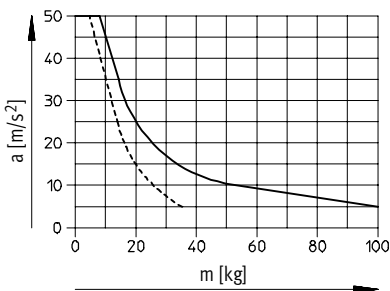

DGE-63

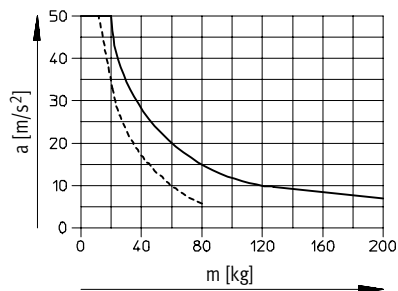

- - - vertical
— horizontal

Toothed belt axes DGE-ZR-KF, with recirculating ball bearing guide

Technical data

Dimensions Download CAD data → www.festo.com/en/engineering

Standard slide GK
Size 8 ... 18

5 Hole for centring pin ZBS-5
 + = plus stroke length

Basic dimensions
→ 5 / 2.1-16

Additional slide KL/KR
Size 18

5 Hole for centring pin ZBS-5
6 Additional slide
 + = plus stroke length

Extended slide GV
Size 18

2 Shock absorber retainer KYP
3 Emergency buffer NPE
5 Hole for centring pin ZBS-5
 + = plus stroke length

Profile

Size 8

Size 12

Size 18

2 Sensor slot for proximity sensor
10 Not suitable for proximity sensor

Size	B7	B8	D11	D13	H7	H10	H12	L1	L13	L17	L18	L19	T4 max.	T8
8	21.5	32	M4	-	35.5	12	-	180	27.5	52	-	-	7	-
12	22	36.5	M4	-	43.5	14	-	216	29	64	-	-	8.5	-
18	32	50.5	M5	M4	57	17	4.3	282	31.5	85	20	78	10	9

Toothed belt axes DGE-ZR-KF, with recirculating ball bearing guide

Technical data



Dimensions

Download CAD data → www.festo.com/en/engineering

Standard slide GK

Size 25 ... 63

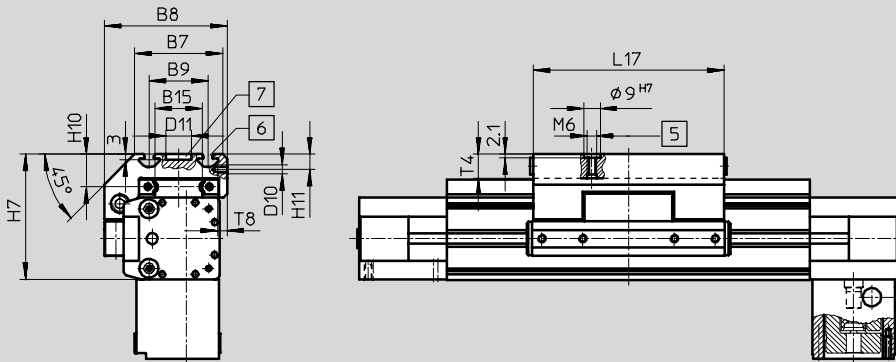

- 5 Hole for centring sleeve ZBH-9
- 6 Mounting slot for slot nut NSTL
- 7 Hole for central mounting SLZZ

Basic dimensions
→ 5 / 2.1-18

Size 40/63

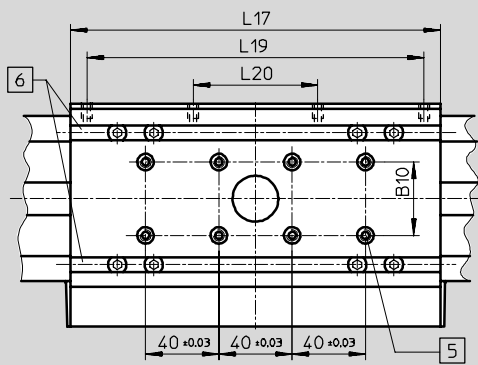

- 5 Hole for centring sleeve ZBH-9
- 6 Mounting slot for slot nut NSTL

Size 25 ... 63

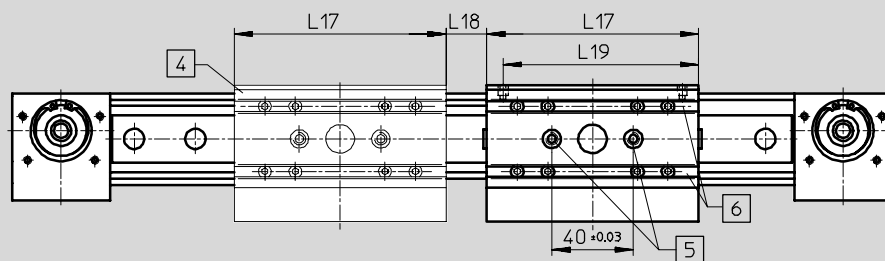

- 4 Additional slide
DGE-...-KL/KR
- 5 Hole for centring sleeve ZBH-9
- 6 Mounting slot for slot nut NSTL

Toothed belt axes DGE-ZR-KF, with recirculating ball bearing guide

Technical data

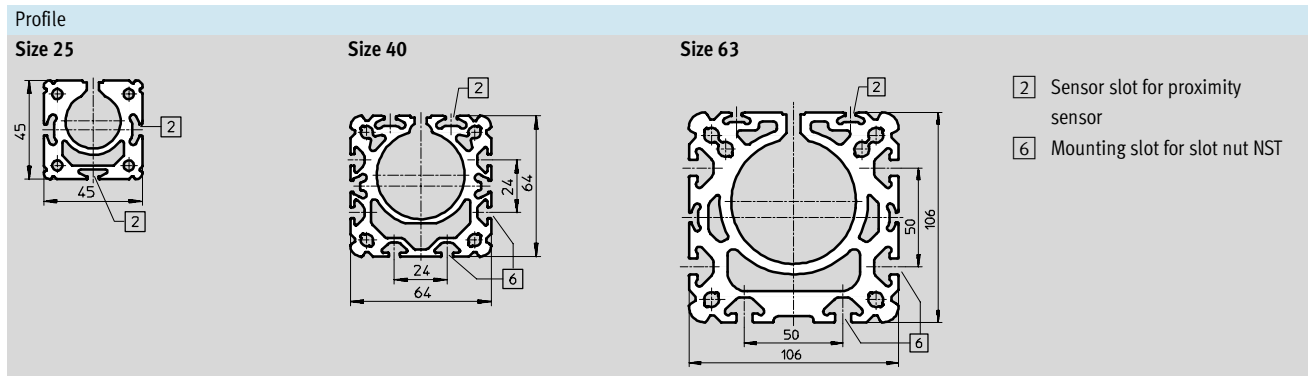

Size	B7	B8	B9	B10	B15	D10	D11	H7
			±0.2				∅ G7	
25	48	67	32	–	23.5	M5	14	68.5
40	78.5	96.5	55	20	42	M5	25	90.5
63	121	142	90	40	71	M8	25	144.5

Size	H10	H11	L17	L18 ¹⁾	L19	L20	T4	T8
					±0.1	±0.1	max.	
25	18.5	8.2	105	20	88	–	12.5	8.5
40	20	7	167	20	150	58	12.5	8.5
63	30	12.5	230	27	200	72	20.5	10.5

1) Recommended minimum distance for access to lubrication nipple.

Toothed belt axes DGE-ZR-KF, with recirculating ball bearing guide

Technical data



Dimensions

Download CAD data → www.festo.com/en/engineering

Extended slide GV

Size 25 ... 63

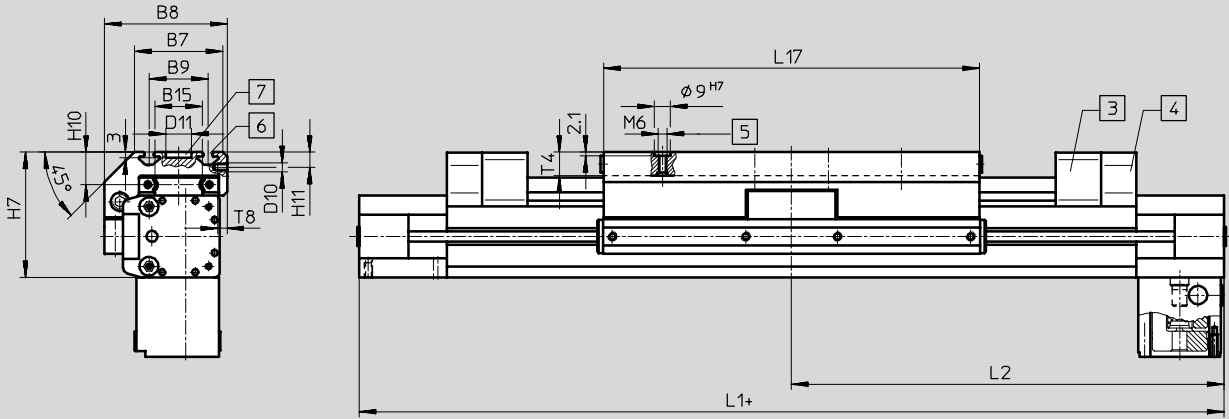

- | | | | |
|--------------------------------------|---|---|----------------------------------|
| 3 Emergency buffer NPE | 5 Hole for centring sleeve ZBH-9 | 7 Hole for central mounting SLZZ | Basic dimensions
→ 5 / 2.1-18 |
| 4 Shock absorber retainer KYP | 6 Slot for slot nut NSTL | + = plus stroke length | |

Size 25

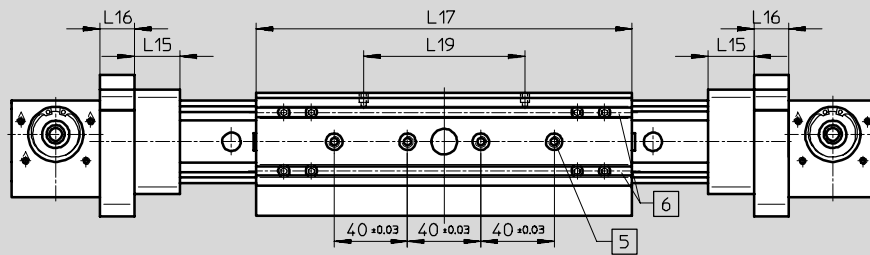

- | |
|---|
| 5 Hole for centring sleeve ZBH-9 |
| 6 Slot for slot nut NSTL |

Size 40/63

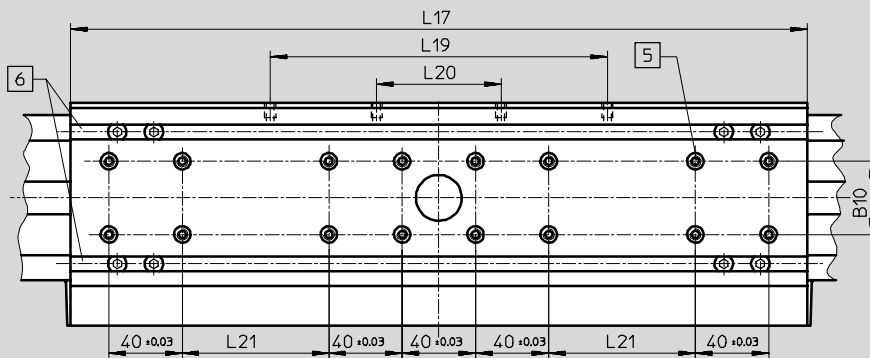

- | |
|---|
| 5 Hole for centring sleeve ZBH-9 |
| 6 Slot for slot nut NSTL |

Toothed belt axes DGE-ZR-KF, with recirculating ball bearing guide

FESTO

Technical data

Size	B7	B8	B9 ±0.2	B15	D10	D11 ∅ G7	H7	H10	H11
25	48	67	32	23.5	M5	14	68.5	18.5	8.2
40	78.5	96.5	55	42	M5	25	90.5	20	7
63	121	142	90	71	M8	25	144.5	30	12.5

Size	L1	L2	l15	L16	L17 ±0.2	L19 ±0.1	L20 ±0.1	L21 ±0.1	T4 max.	T8
25	472	236	25	19	205	88	–	–	12.5	8.5
40	739	369.5	40	32	337	150	58	40	12.5	8.5
63	1132	566	60	44	480	200	72	120	20.5	10.5

Toothed belt axes DGE-ZR-KF, with recirculating ball bearing guide

Technical data



Dimensions

Download CAD data → www.festo.com/en/engineering

Protected version GA

Size 25

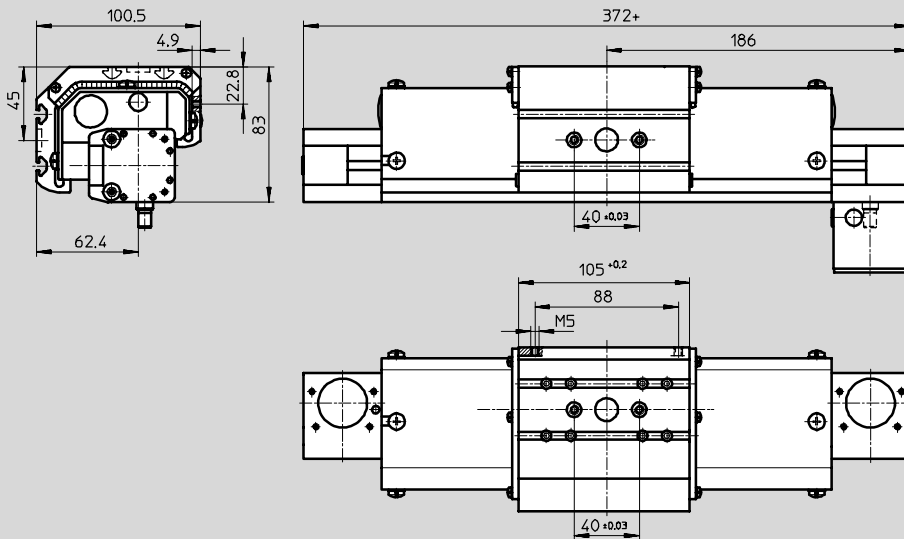

+ = plus stroke length

Size 40

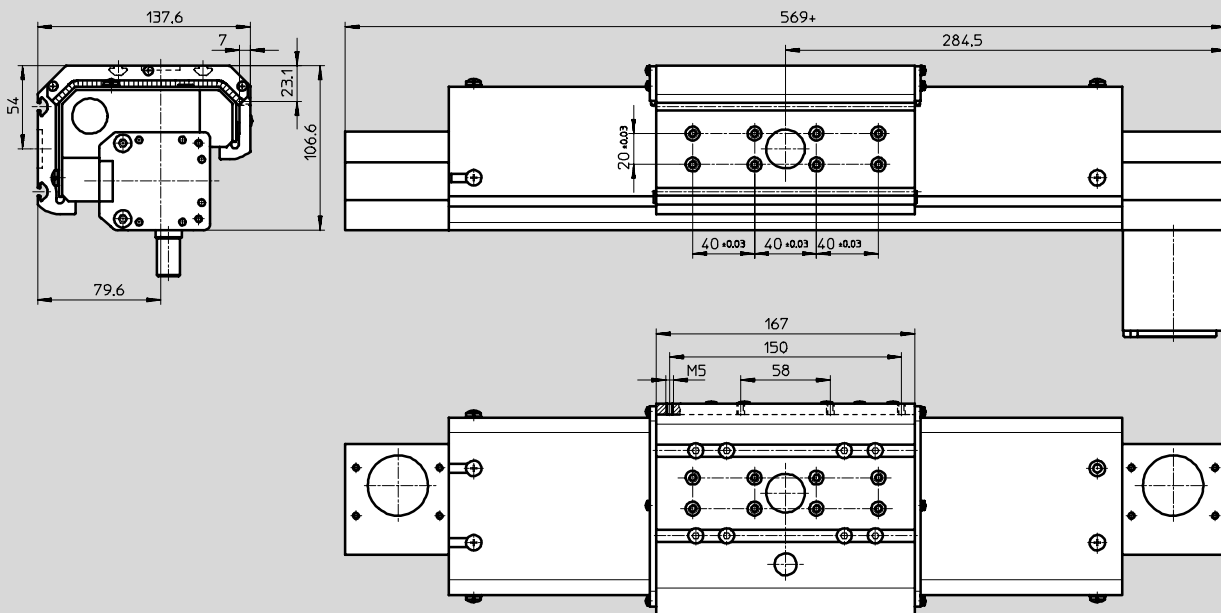

Toothed belt axes DGE-ZR-KF, with recirculating ball bearing guide

Ordering data – Modular products

Order code
Mandatory data

Standard slide GK

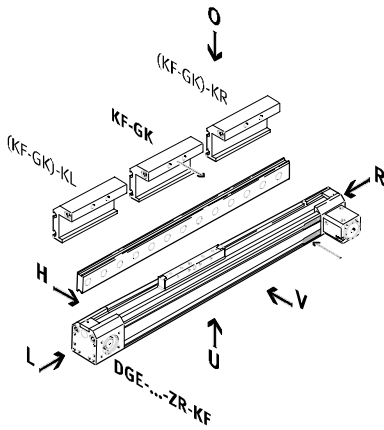

Extended slide GV

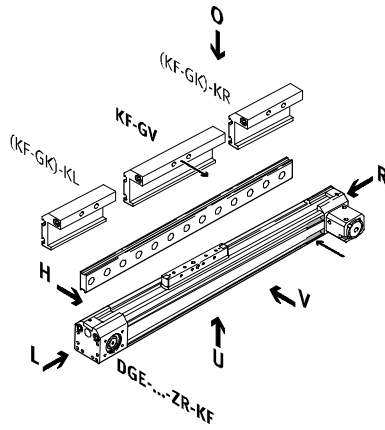

Protected version GA

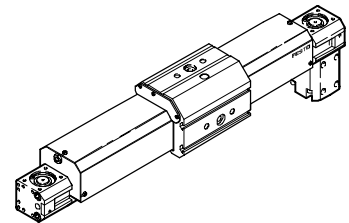

Drive shaft

- LK No drive shaft on left
- LV Drive shaft on left, front
- LH Drive shaft on left, rear
- LB Drive shaft on left, front and rear
- RK No drive shaft on right
- RV Drive shaft on right, front
- RH Drive shaft on right, rear
- RB Drive shaft on right, front and rear

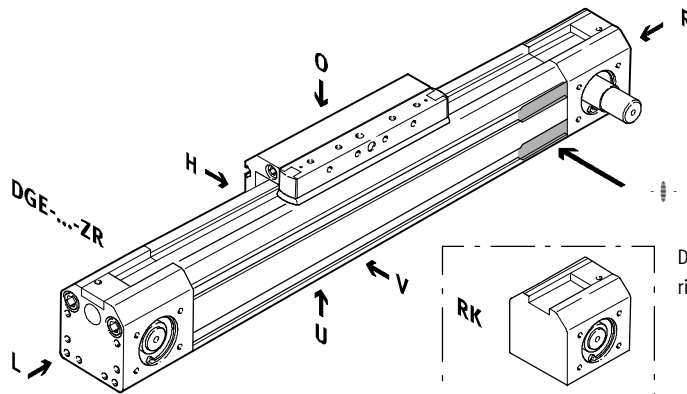

Drive shaft left

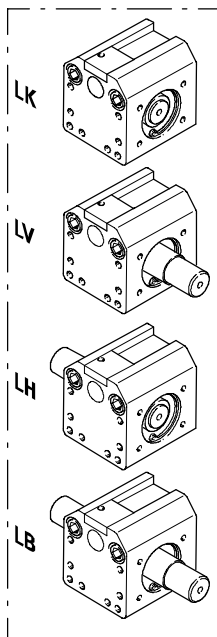

Drive shaft right

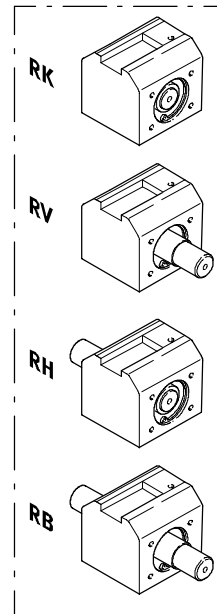

Note
The insertion point for the proximity sensor is located on the right side of the toothed belt axis

- O top
- U underneath
- R right
- L left
- V front
- H rear

Toothed belt axes DGE-ZR-KF, with recirculating ball bearing guide

Ordering data – Modular products

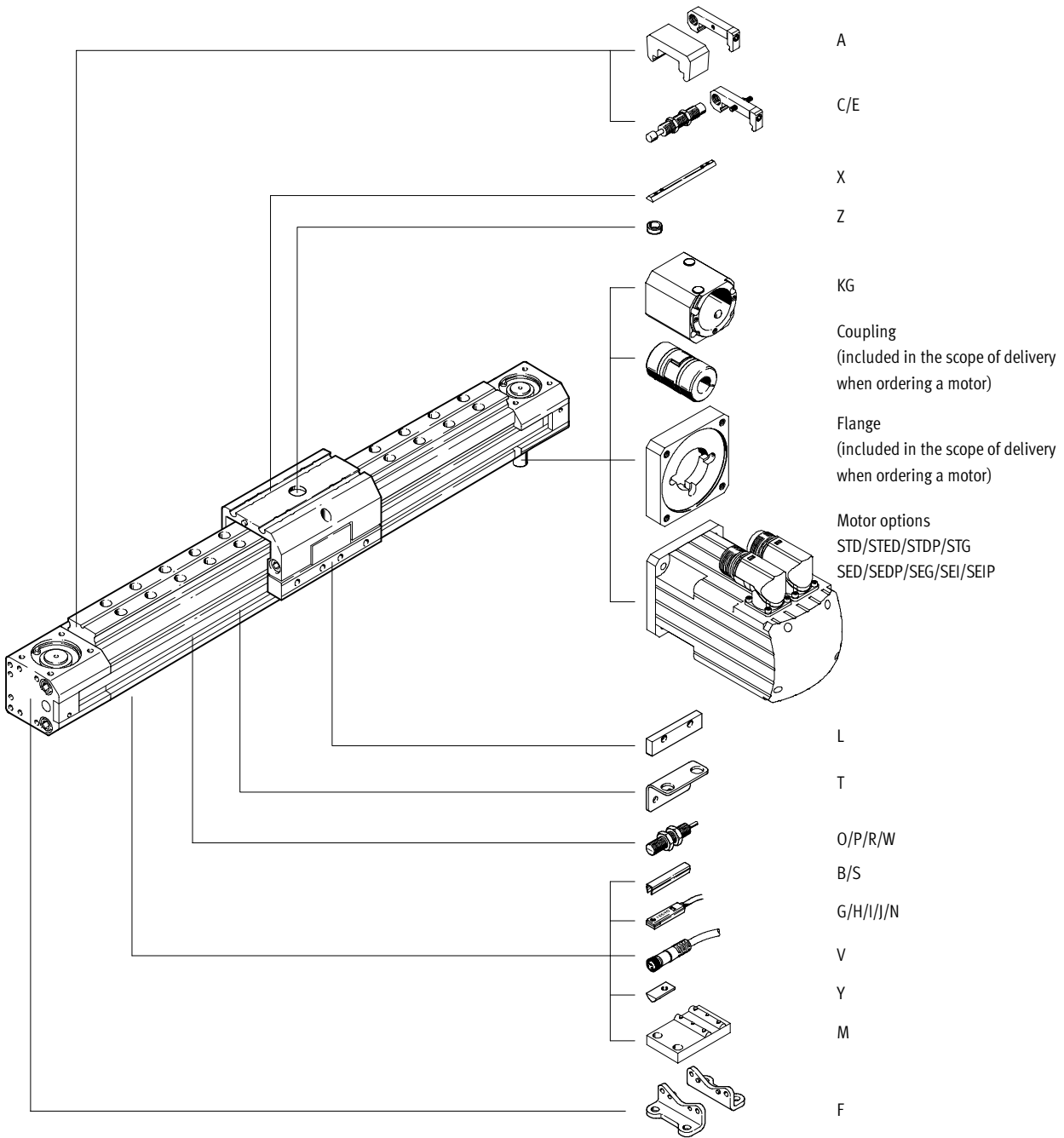

Toothed belt axes DGE-ZR-KF, with recirculating ball bearing guide



Ordering data – Modular products

M Mandatory data							O Options		
Module No.	Design	Size	Stroke	Drive function	Drive shaft on left	Drive shaft on right	Coupling housing	Guide	Slide
193 739	DGE	8	1 ... 4500	ZR	LK	RK	KG	KF	GK GV GA
193 740		12							
193 741		18							
193 742		25							
193 743		40							
193 744		63							
Ordering example									
193 743	DGE	- 40	- 800	- ZR	- LK	- RV	- KG	- KF	- GK

Ordering table											
Size	8	12	18	25	40	63	Condi- tions	Code	Enter code		
M Module No.	193 739	193 740	193 741	193 742	193 743	193 744					
Design	Electromechanical linear axis								DGE	DGE	
Size	8	12	18	25	40	63		-...			
Stroke [mm]	1 ... 650	1 ... 1000		1 ... 3000	1 ... 4000	1 ... 4500	1	-...			
Drive function	Electromechanical drive with toothed belt								-ZR	-ZR	
Drive shaft on left	No drive shaft on left							2	-LK		
	Drive shaft on left, front								-LV		
	Drive shaft on left, rear								-LH		
	Drive shaft on left, front and rear								-LB		
Drive shaft on right	No drive shaft on right							3	-RK		
	Drive shaft on right, front								-RV		
	Drive shaft on right, rear								-RH		
	Drive shaft on right, front and rear								-RB		
O Coupling housing	Coupling housing								-KG		
Guide	Recirculating ball bearing guide							4	-KF	-KF	
Slide	Standard								-GK		
	Extended (maximum stroke for DGE-...-ZR-KF-GV)	-	-	Extended (920 mm)	(2 900 mm)	(3 830 mm)	(4 250 mm)		-GV		
	Dust protection (maximum stroke for DGE-...-ZR-KF-GA)	-	-	-	Dust proof version (1 800 mm)	(1 800 mm)	-		-GA		

1 Stroke Special stroke lengths on request.
2 LK Not with drive shaft on right RK.

3 RK Not with drive shaft on left LK.
4 KF Only with slide GK, GV, GA.

Transfer order code

Toothed belt axes DGE-ZR-KF, with recirculating ball bearing guide

Ordering data – Modular products



Options

Additional slide	Motor type	Brake
KL KR	STD STED STDP STG SED SEDP SEG SEI SEIP	BR
-	- SEIP	- BR

Electrical positioning systems
Electromechanical drives

2.1

Ordering table

Size	8	12	18	25	40	63	Condi- tions	Code	Enter code	
Additional slide	Left (effective stroke reduction)	-	-	Standard slide left (85 mm) (105 mm)	(167 mm)	(230 mm)	5	-KL		
	Right (effective stroke reduction)	-	-	Standard slide right (85 mm) (105 mm)	(167 mm)	(230 mm)	5	-KR		
Motor type	Stepper motor	Stepper motor				-	-	6	-STD	
		with integrated power electronics				-	-	6	-STED	
		-				for high performance	-	-	6	-STDP
		-				-	with gear unit	-	6	-STG
		-				-	-	-	6	-SEG
	Servo motor	Servo motor				-	-	6	-SED	
		for high performance				-	for high performance	-	6	-SEDP
		-				with gear unit	-	-	6	-SEG
		-				-	with integrated gearing	-	6	-SEI
		-				with integrated gearing for high performance	-	-	6	-SEIP
Brake	Motor brake						7	-BR		

5 **KL, KR** Only with slide GK or GV.

7 **BR** Only permissible with motor type.

6 **Motor type** Only with coupling housing KG.

Allocation of order codes to motor types

→ from 5 / 2.1-78

The motor controller and cable set must be ordered separately.

Stepper motor → 5 / 2.2-2

Servo motor → 5 / 2.2-16

Transfer order code

- - -

Toothed belt axes DGE-ZR-KF, with recirculating ball bearing guide

Ordering data – Modular products



Options												
Accessories	Slot cover	Slot nut	Central support	Foot mounting	Emergency buffer and retainer	Shock absorber	Centring sleeve	Proximity sensor	Plug socket	Sensor bracket	Switching lug	Inductive sensor
ZUB	...S ...B	...Y ...X	...M	...F	...A	...C ...E	...Z	...G ...H ...I ...J ...N	...V	...T	...L	...O ...P ...W ...R
ZUB	2S2B	10Y2X		F				2I				

Ordering table												
Size		8	12	18	25	40	63	Condi- tions	Code	Enter code		
↓	Accessories	Supplied separately								ZUB-	ZUB-	
0	Slot cover	Sensor slot	1 ... 10								...S	
		Mounting slot	-	-	-	-	1 ... 10		...B			
	Slot nut	for mounting slot	-	-	1 ... 10				...Y			
		for slide	-	-	-	1 ... 10			...X			
	Central support	1 ... 10								...M		
	Foot mounting (kit)	1 ... 10								...F		
	Emergency buffer and retainer for KF	-	-	1 ... 2				8	...A			
	Shock absorber and retainer for KF-GK, KF-GV	1 ... 2							9	...C		
		for KF-GA	-	-	-	1 ... 2		-	10	...E		
	Centring sleeve (pack of 10)	10, 20, 30, 40, 50, 60, 70, 80, 90								...Z		
	Proximity sensor	with cable 2.5 m	1 ... 10								...G	
		with plug	1 ... 10								...H	
		contactless with cable 2.5 m	1 ... 10								...I	
		contactless, plug	1 ... 10								...J	
		NC contact with cable 2.5 m	1 ... 10								...N	
	Plug socket with cable 2.5 m	1 ... 10								...V		
	Sensor bracket for inductive sensors	-	-	1 ... 5				9	...T			
	Switching lug	-	-	1				9	L			
	Inductive sensor	NO contact, cable	-	-	1 ... 5			9	...O			
		NC contact, cable	-	-	1 ... 5			9	...P			
		NO contact, plug	-	-	1 ... 5			9	...W			
		NC contact, plug	-	-	1 ... 5			9	...R			

8 A Only with slide GK.
Mounted as standard for slide GV, GA

10 E Only with slide GA.

9 C, T, L, O, P, W, R
Not with slide GA.

Transfer order code

ZUB -

Toothed belt axes DGE-ZR-RF, with roller guide

Peripherals overview



Electrical positioning systems
Electromechanical drives

2.1

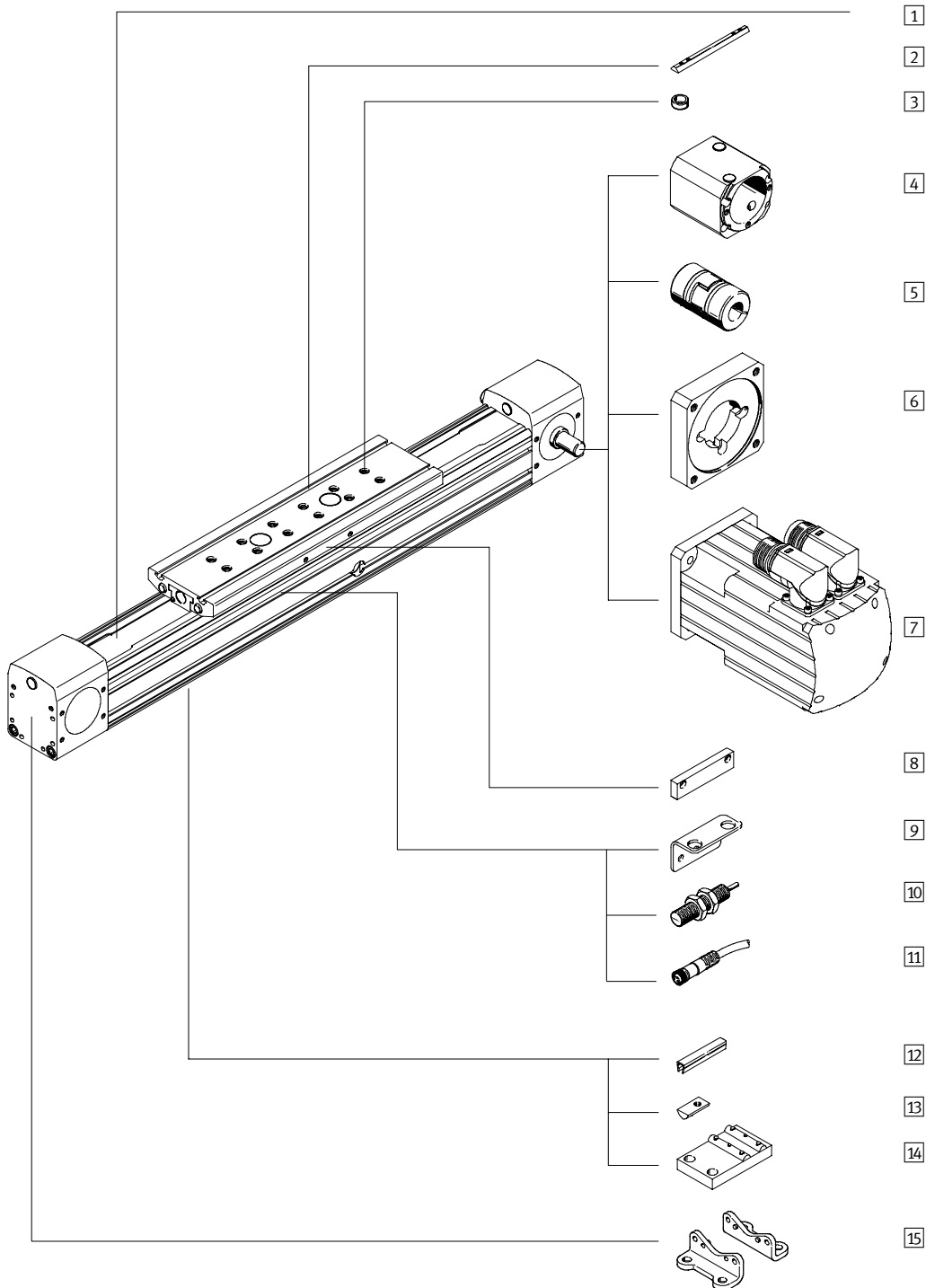

Toothed belt axes DGE-ZR-RF, with roller guide

Peripherals overview

Variants and accessories		
Type	Brief description	→ Page
1 Toothed belt axis DGE-RF	Electromechanical axis with roller guide	5 / 2.1-52
2 Slot nut for slide X	For mounting loads and attachments on the slide	5 / 2.1-87
3 Centring sleeve Z	For centring loads and attachments on the slide	5 / 2.1-87
4 Coupling housing KG	Adapter for mounting the motor on the axis	5 / 2.1-78
5 Coupling KSE	Connecting element between axis and motor	5 / 2.1-78
6 Motor flange MTR-FL	Connecting element between coupling housing and motor	5 / 2.1-78
7 Motor MTR	Motors specially matched to the axis, with or without gearing, with or without brake	5 / 2.1-78
8 Switching lug L	For sensing the slide position	5 / 2.1-88
9 Sensor bracket T	Adapter for mounting the sensors on the axis	5 / 2.1-88
10 Inductive proximity sensor O/P/W/R	For use as a proximity signal and safety monitor	5 / 2.1-90
11 Plug socket with cable V	For proximity sensors	5 / 2.1-90
12 Slot cover B	For protecting against the ingress of dirt	5 / 2.1-87
13 Slot nut for profile slot Y	For mounting attachments	5 / 2.1-87
14 Central support M	For mounting the axis	5 / 2.1-82
15 Foot mounting F	For mounting the axis	5 / 2.1-81

Toothed belt axes DGE-ZR-RF, with roller guide

Type code

DGE - 25 - 500 - ZR - RF - LK - RV - GK - KG - SED -

Type	
DGE	Toothed belt drive
Size	
25	
500	
Stroke [mm]	
500	
Drive function	
ZR	Toothed belt
Guide	
RF	Roller guide
Drive shaft on left	
LK	No drive shaft on left
LV	Drive shaft on left, front
LH	Drive shaft on left, rear
LB	Drive shaft on left, front and rear
Drive shaft on right	
RK	No drive shaft on right
RV	Drive shaft on right, front
RH	Drive shaft on right, rear
RB	Drive shaft on right, front and rear
Slide length	
GK	Standard slide
GV	Extended slide
Coupling housing	
KG	Coupling housing
Motor type	
SED	Servo motor
SEG	Servo motor with gear unit
SEGP	Servo motor with gear unit for high performance
SEI	Servo motor with integrated gearing
SEIP	Servo motor with integrated gearing for high performance
Motor brake	
BR	Brake

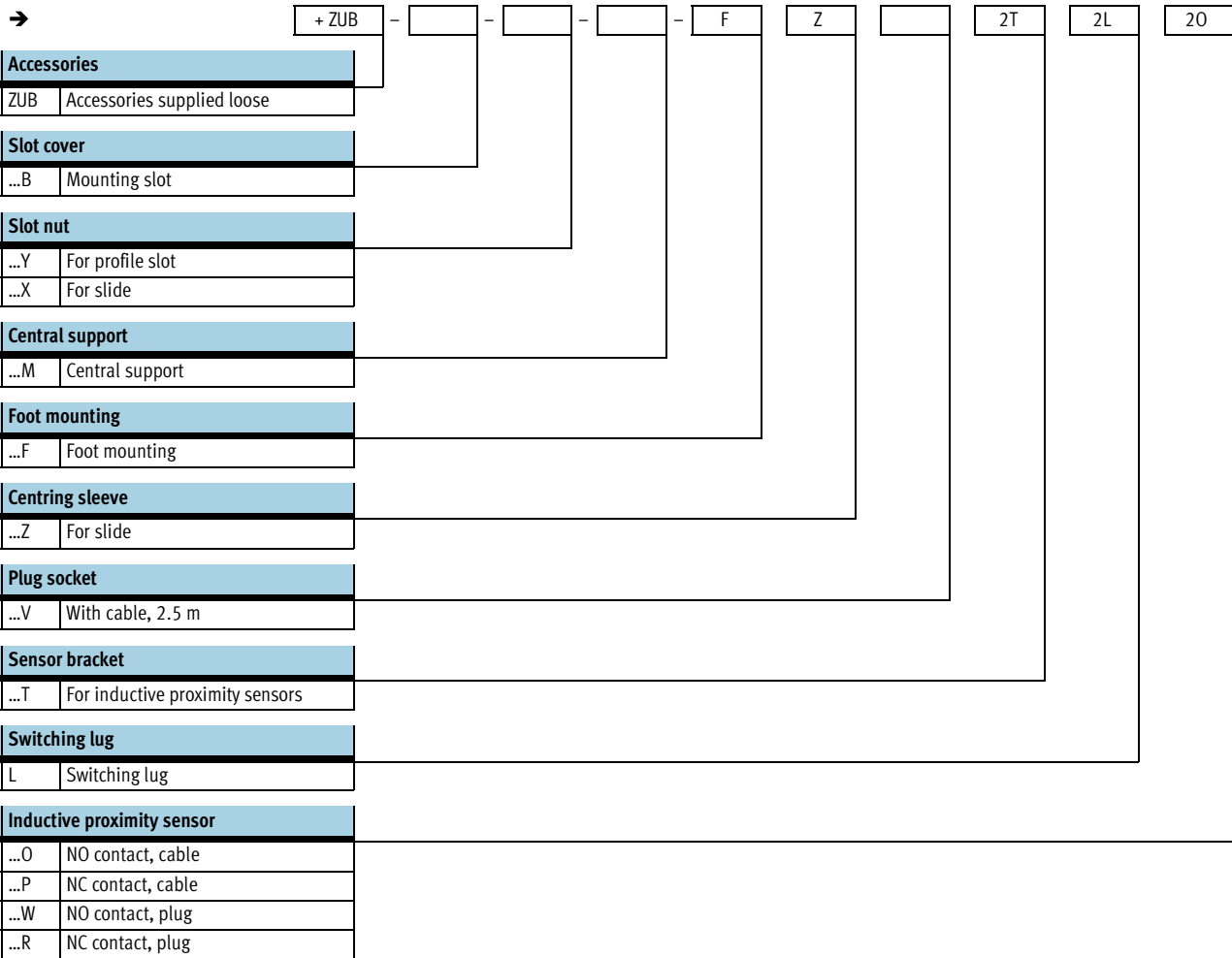

Toothed belt axes DGE-ZR-RF, with roller guide

Type code



Toothed belt axes DGE-ZR-RF, with roller guide

Technical data

-  - Size
25, 40 and 63
-  - Stroke length
1 ... 5000 mm



General technical data			
Size	25	40	63
Constructional design	Electromechanical axis with toothed belt and internal roller guide		
Guide	Internal roller guide		
Mounting position	Any		
Max. working stroke ¹⁾ [mm]	1 ... 5000	1 ... 5000	1 ... 5000 ²⁾
Max. working load [kg]	15	30	60
Max. feed force F _x [N]	260	610	1 500
Max. driving torque [Nm]	3.7	12.1	55.38
Max. no-load torque [Nm]	0.5	1.0	4.5
Max. speed [m/s]	10		
Repetition accuracy [mm]	±0.1		

- 1) Total stroke = working stroke + 2x stroke reserve
- 2) In the case of the variant with extended slide (-GV), the maximum working stroke is 4,800 mm.

Operating and environmental conditions			
Size	25	40	63
Ambient temperature [°C]	0 ... +60		
Protection class	IP40		

Weights [kg]						
Size	25		40		63	
	GK	GV	GK	GV	GK	GV
Basic weight with 0 mm stroke	2.61	3.15	7.75	9.32	29.81	34.91
Additional weight per 100 mm stroke	0.30		0.61		1.44	
Moving load	0,62	0,85	2,00	2,70	5,20	7,00

Mass moment of inertia						
Size	25		40		63	
	GK	GV	GK	GV	GK	GV
J ₀ [kg cm ²]	1.75	2.75	9.89	15.37	108.11	156.71
J _H per metre stroke [kg cm ² /m]	0.188		0.933		7.605	
J _L per kg working load [kg cm ² /kg]	2.052		3.958		13.634	

The mass moment of inertia J_A of the entire axis is calculated as follows:

$$J_A = J_0 + J_H \times \text{working stroke [m]} + J_L \times m_{\text{working load [kg]}}$$

Toothed belt axes DGE-ZR-RF, with roller guide

Technical data

Toothed belt				
Size		25	40	63
Tensile stress ¹⁾	[%]	0.16	0.11	0.15
Pitch	[mm]	3	5	8
Effective radius; effective diameter	[mm]	28.65	39.79	73.85
Feed constant	[mm]	90	125	232

1) At max. feed force

Materials

Sectional view

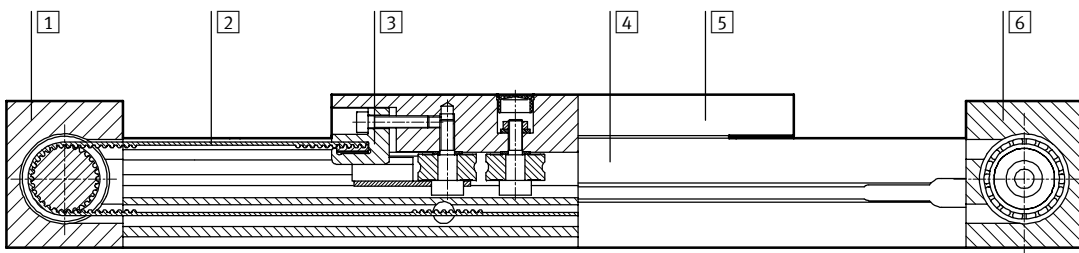

Axis		
1	Return pulley housing	Anodised aluminium
2	Toothed belt	Polychloroprene with Glascord and nylon coating
3	Clamping component	Special steel casting
4	Profile	Anodised aluminium
5	Slide	Anodised aluminium
6	Drive housing	Anodised aluminium

Stroke reserve

L9 The stroke reserve is a safety distance available on both sides of the axis in addition to the stroke.

L6 Slide length

L8 Stop element

L1+ Overall length of axis

1 Working stroke

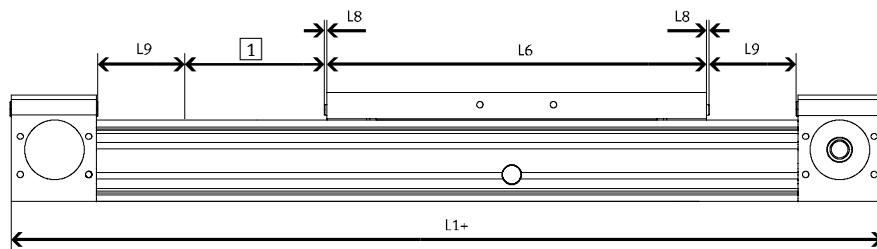

Example:

Type DGE-25-500-ZR-RF

Working stroke = 500 mm

Stroke reserve = (2x 63 mm)

= 126 mm

Total stroke = 500 mm + 126 mm

= 626 mm

Size	25	40	63
L9 per end position [mm]	63	100	172

Toothed belt axes DGE-ZR-RF, with roller guide

Technical data



Characteristic load values

The indicated forces and torques refer to the centre of the guide. They must not be exceeded in the dynamic range. Special attention must be paid to the cushioning phase.

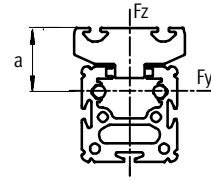
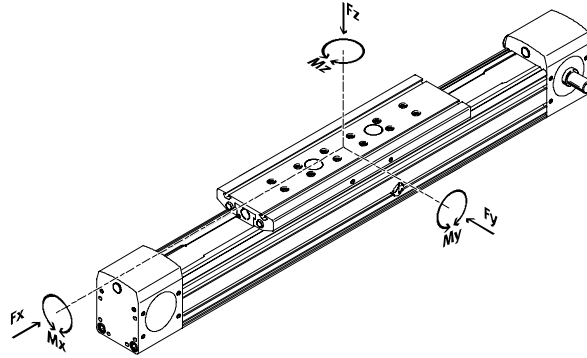

Distance a with:
 DGE-25: 30 mm
 DGE-40: 37 mm
 DGE-63: 44.6 mm

If the drive is subjected to more than two of the indicated forces and torques simultaneously, the following equations must be satisfied in addition to the indicated maximum loads.

$$\frac{F_y}{F_{y_{max}}} + \frac{F_z}{F_{z_{max}}} + \frac{M_x}{M_{x_{max}}} + \frac{M_y}{M_{y_{max}}} + \frac{M_z}{M_{z_{max}}} \leq 1$$

Permissible forces and torques								
Size	25			40		63		
	Slide design			GK	GV	GK	GV	
$F_{x_{max}}$	[N]	260			610		1500	
$F_{y_{max}}$	[N]	150			300		600	
$F_{z_{max}}$	[N]	150			300		600	
$M_{x_{max}}$	[Nm]	7			18		65	
$M_{y_{max}}$	[Nm]	15	30	60	120	170	340	
$M_{z_{max}}$	[Nm]	15	30	90	180	300	600	

2nd moment of area

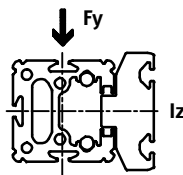
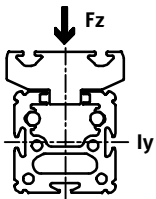

Size		25	40	63
I_y	[mm ⁴]	5.947×10^5	2.479×10^6	1.664×10^7
I_z	[mm ⁴]	2.372×10^5	9.463×10^5	5.997×10^6



Design tool
 PtTool
www.festo.com/en/engineering

Toothed belt axes DGE-ZR-RF, with roller guide

Technical data

Maximum permissible support span l as a function of the applied load m

The axis may need to be supported with central supports MUP in order to restrict deflection with long stroke lengths. The following diagrams serve

to determine the maximum permissible support span as a function of the applied load acting upon the axis.

A distinction is made here between forces acting upon the surface of the slide and forces acting upon the front of the slide.

1 Load on the surface of the slide

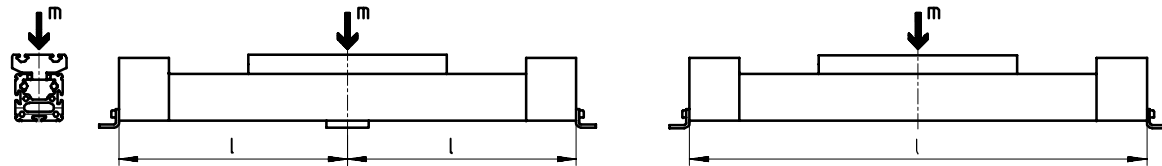

2 Load on the front of the slide

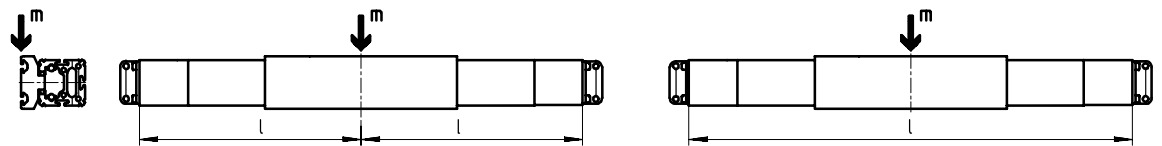

Maximum support span l (without central support) as a function of the applied load m

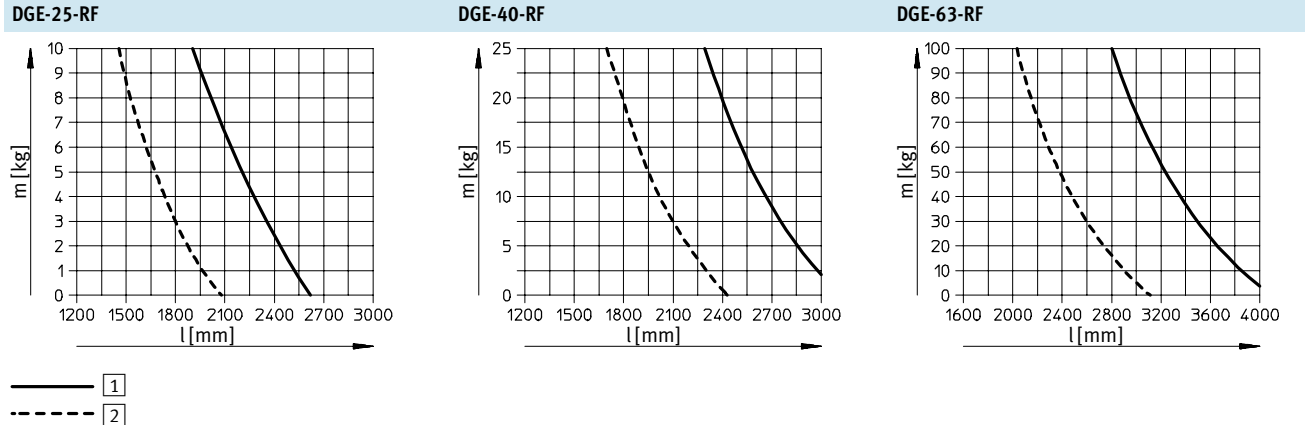

Maximum acceleration as a function of the applied load m

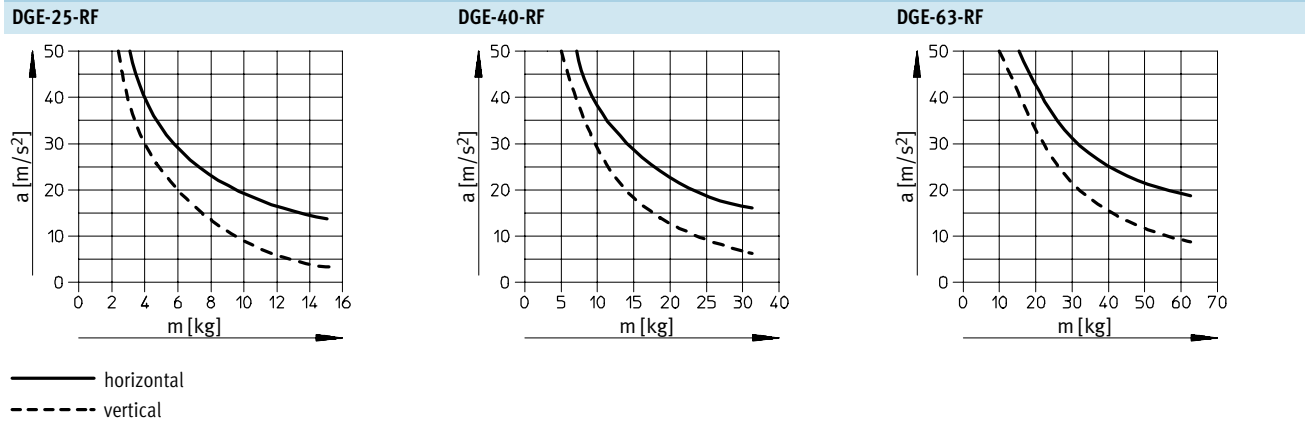

Toothed belt axes DGE-ZR-RF, with roller guide

Technical data

Dimensions

Download CAD data → www.festo.com/en/engineering

DGE-25/-40/-63

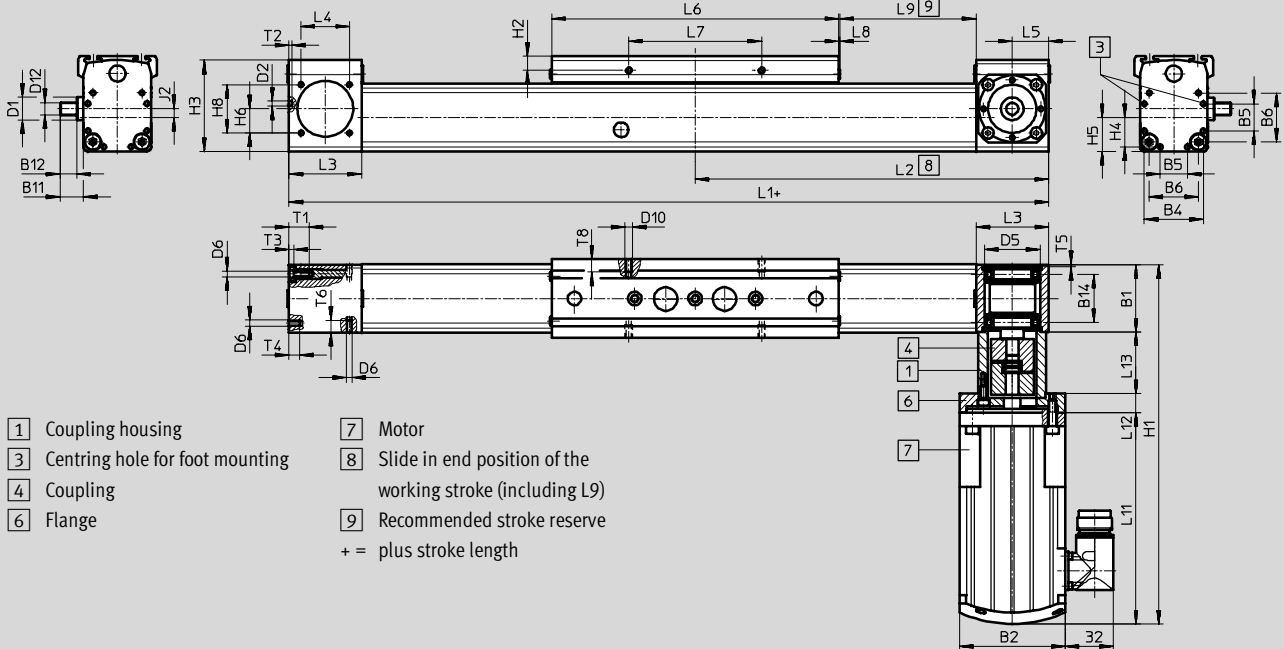

- 1 Coupling housing
- 2 Centring hole for foot mounting
- 3 Coupling
- 4 Flange
- 5 Motor
- 6 Slide in end position of the working stroke (including L9)
- 7 Recommended stroke reserve
- + = plus stroke length

DGE-25

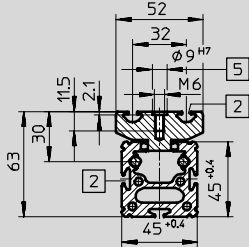

- 2 Slot for slot nuts
- 5 Hole for centring sleeve ZBH-9 and mounting thread

DGE-40

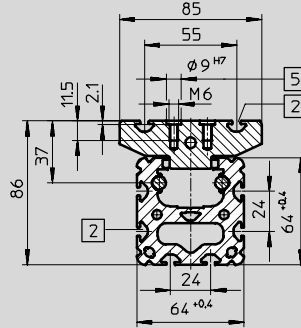

DGE-63

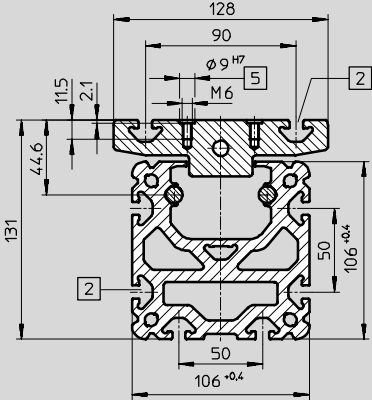

DGE-25-GK

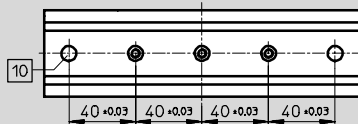

DGE-40-GK

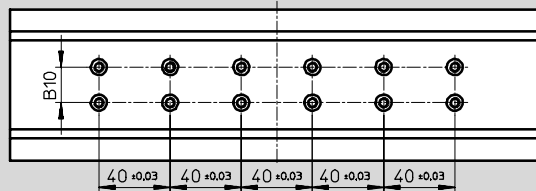

DGE-25-GV

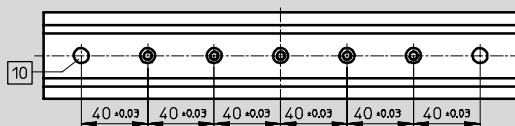

DGE-40-GV, DGE-63-GK

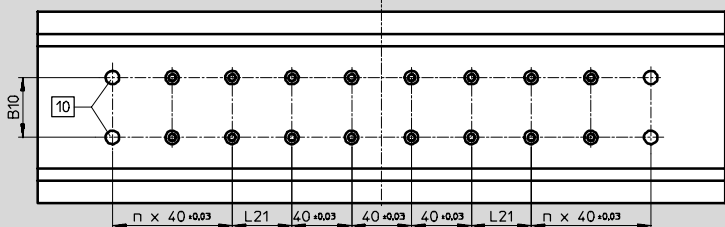

- 10 Hole for centring sleeve ZBH-9

Toothed belt axes DGE-ZR-RF, with roller guide

Technical data

DGE-63-GV

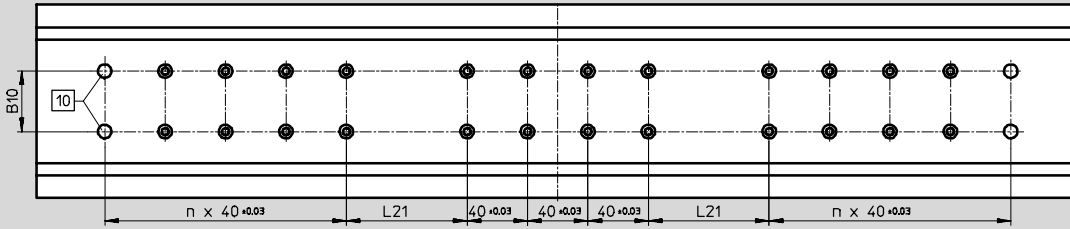

Size		B1	B4	B5	B6	B10 ±0.03	B11	B12	B14	D1 ∅	D2	D5 H7	D6	D10	D12 ∅ h6
25	GK	45	39.1	18	32.5	-	15.6	11	31.8	15	3.3 _{+0.1}	37	M4	M5	8
	GV														
40	GK	64	53	28	49	20	29.6	24.5	45.5	20	4.4 _{H13}	47	M5	M5	15
	GV														
63	GK	106	89	44	83	40	41.1	35.2	74.3	35	6.4 _{+0.1}	80	M8	M8	25
	GV														

Size		H2	H3	H4	H5	H6	H8	J2	L1	L2	L3	L4	L5	L6	L7
25	GK	9.3	60.4	19.6	22.5	16	32	5.8	414	207	48	32	24	190	88
	GV								509	254.5				285	
40	GK	9.5	83.8	26.5	32	19.5	30	8.8	638	319	67	54	34	300	58
	GV								778	389				440	
63	GK	10.5	129.3	44.5	52.8	27.5	49	10.1	1020	510	106	84	55	460	72
	GV								1250	625				690	

Size		L8	L9	L13	L21 ±0.03	n	T1	T2	T3	T4	T5	T6	T8
25	GK	1	63	40	-	-	10	2	3	7	< 1.6	8	8.5
	GV												
40	GK	2	100	65	40	-	12	3	5	12	< 2.9	12	8.5
	GV					2							
63	GK	2	172	91	40	2	21	4	6.5	22	< 5.1	15	12
	GV				80	4							

Size	Motor type	B2	H1	L11	L12	L13	
25	SEG	55	324	219	20	40	
	SEG + BR		341	236			
	SED	70	237.3	139.8	12.5		
	SED + BR		259.3	161.8			
	SEGP		329.3	231.8			
	SEGP + BR		351.3	253.8			
40	SEI	100.5	391.6	241.6	21	65	
	SEI + BR		412.7	262.7			
	SED		423.2	273.2			
	SED + BR		444.3	294.3			
63	SEI		100.5	463.6	241.6	25	91
	SEI + BR			484.7	262.7		
	SEIP			565.6	343.6		
	SEIP + BR			586.7	364.7		

Toothed belt axes DGE-ZR-RF, with roller guide

Ordering data – Modular products

Order code

Mandatory data

GK Standard slide

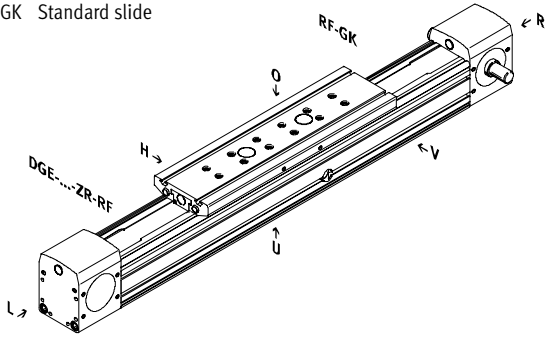

GV Extended slide

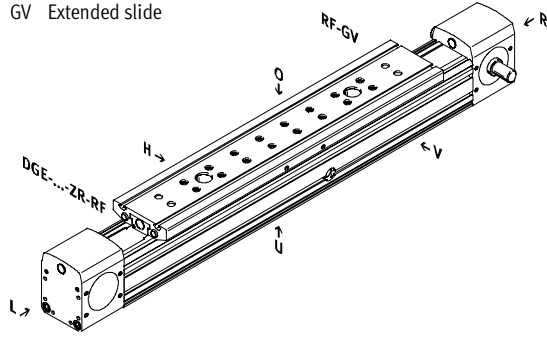

Drive shaft

- LK No drive shaft on left
- LV Drive shaft on left, front
- LH Drive shaft on left, rear
- LB Drive shaft on left, front and rear
- RK No drive shaft on right
- RV Drive shaft on right, front
- RH Drive shaft on right, rear
- RB Drive shaft on right, front and rear

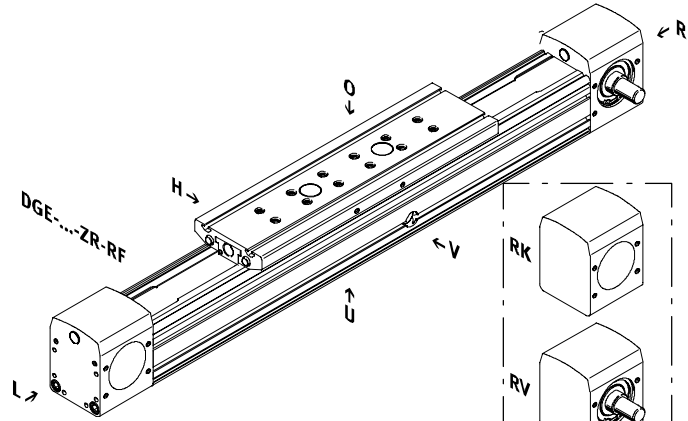

Drive shaft left

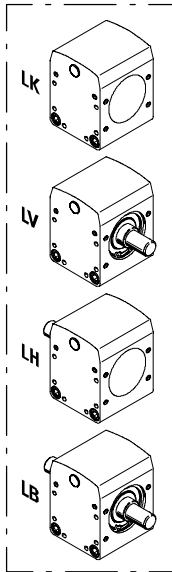

Drive shaft right

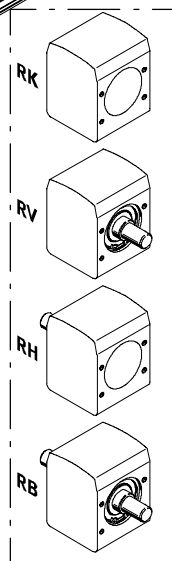

- O top
- U underneath
- R right
- L left
- V front
- H rear

Toothed belt axes DGE-ZR-RF, with roller guide

Ordering data – Modular products

Order code
Options

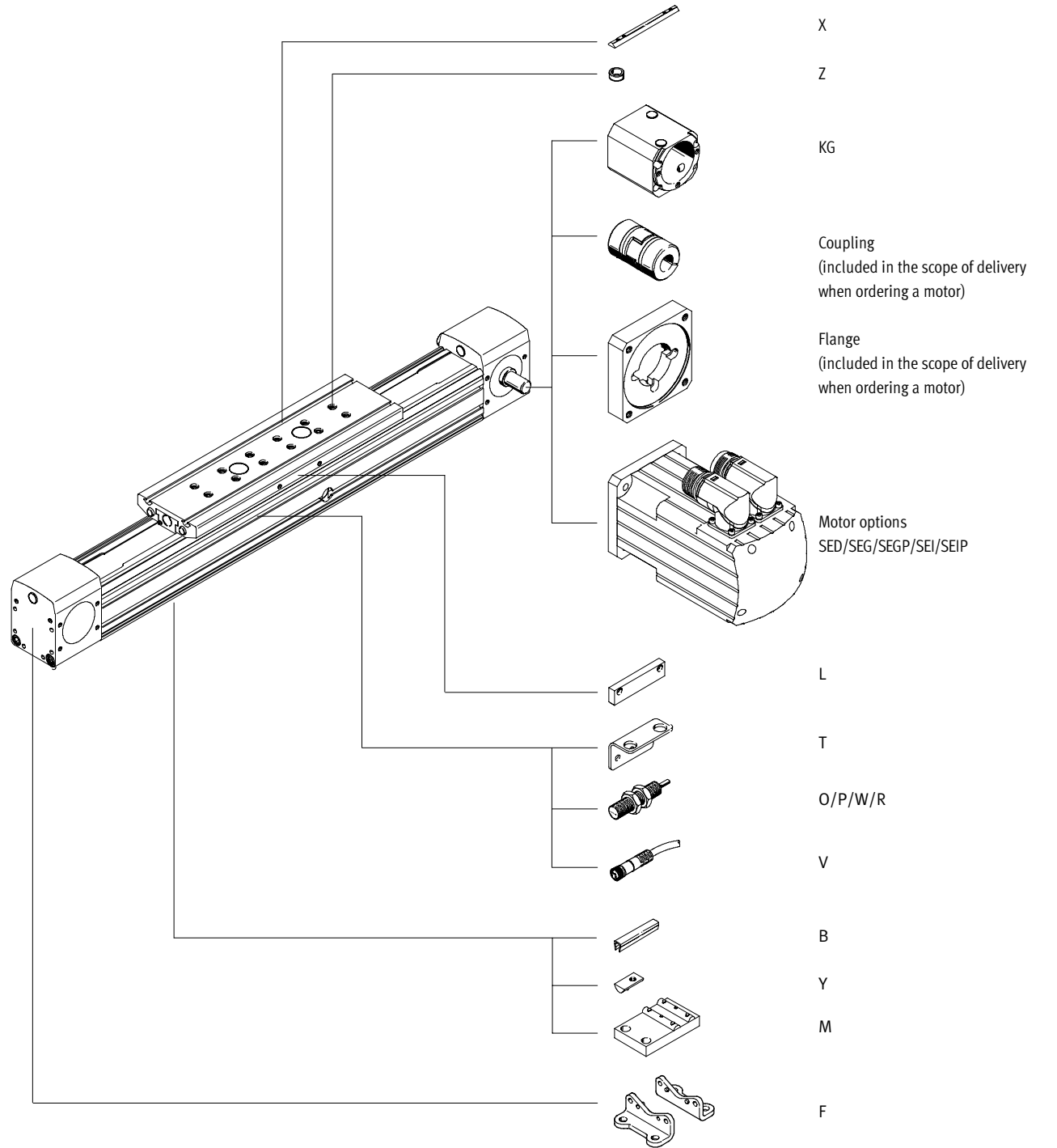

Toothed belt axes DGE-ZR-RF, with roller guide

Ordering data – Modular products



2.1

Mandatory data								
Module No.	Design	Size	Stroke	Drive function	Guide	Drive shaft on left	Drive shaft on right	Slide
534 391	DGE	25	1 ... 5 000	ZR	RF	LK	RK	GK GV
534 392		40				LV	RV	
534 393		63				LH LB	RH RB	
Ordering example								
534 391	DGE	- 25	- 600	- ZR	- RF	- LK	- RV	- GK

Ordering table							
Size	25	40	63	Condi- tions	Code	Enter code	
M Module No.	534 391	534 392	534 393				
Design	Electromechanical linear drive				DGE	DGE	
Size	25	40	63		-...		
Stroke [mm]	1 ... 5000	1 ... 5000	1 ... 5000		-...		
Drive function	Electromechanical drive with toothed belt				-ZR	-ZR	
Guide	Roller guide				-RF	-RF	
Drive shaft on left	No drive shaft on left			1	-LK		
	Drive shaft on left, front				-LV		
	Drive shaft on left, rear				-LH		
	Drive shaft on left, front and rear				-LB		
Drive shaft on right	No drive shaft on right			2	-RK		
	Drive shaft on right, front				-RV		
	Drive shaft on right, rear				-RH		
	Drive shaft on right, front and rear				-RB		
Slide	Standard slide				-GK		
	Extended slide			3	-GV		

- 1 LK Not with drive shaft on right RK.
- 2 RK Not with drive shaft on left LK.

- 3 GV Maximum stroke: Size 63: 4800 mm

Allocation of order codes to motor types
 → 5 / 2.1-80 The motor controller and cable set must be ordered separately.
 Servo motor → 5 / 2.2-16

Transfer order code

Toothed belt axes DGE-ZR-RF, with roller guide

Ordering data – Modular products

Options			
Coupling housing	Motor type	Brake	Accessories
KG	SED SEG SEGP SEI SEIP	BR	...B ...Y ...X ...M ...F ...Z ...V ...T L ...O ...P ...W ...R
- KG	- SEGP	- BR	+ 2X2T202P

Ordering table						
Size	25	40	63	Condi- tions	Code	Enter code
Options						
Coupling housing	Coupling housing			[4]	-KG	
Motor type	Servo motor		-	[5]	-SED	
	Servo motor with gear unit	-	-	[5]	-SEG	
	Servo motor with gear unit for high performance	-	-	[5]	-SEGP	
	-	Servo motor with integrated gearing		[5]	-SEI	
	-	-	Servo motor with integrated gearing for high performance	[5]	-SEIP	
	Brake	Motor brake				-BR
Accessories	Supplied separately				+	+
Slot cover for mounting slot	1 ... 10				...B	
Slot nut	for profile slot				...Y	
	for slide				...X	
Central support	1 ... 10				...M	
Foot mounting (kit)	1 ... 10				...F	
Centring sleeve (pack of 10)	10, 20, 30, 40, 50, 60, 70, 80, 90				...Z	
Plug socket with cable, 2.5 m	1 ... 10				...V	
Sensor bracket for inductive sensors	1 ... 5				...T	
Switching lug	1				L	
Inductive proximity sensor	NO contact with cable	1 ... 5			...O	
	NC contact with cable	1 ... 5			...P	
	NO contact with plug	1 ... 5			...W	
	NC contact with plug	1 ... 5			...R	

[4] **KG** Mounted if only one drive shaft available, otherwise supplied loose.

[5] **SED, SEG, SEGP, SEI, SEIP**
Only with coupling housing KG, motor supplied loose.

Transfer order code

- - - +

Toothed belt axes DGE-ZR-HD, with heavy-duty guide

Peripherals overview

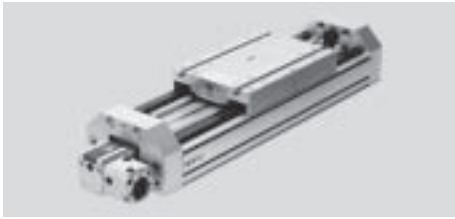

Electrical positioning systems
Electromechanical drives

2.1

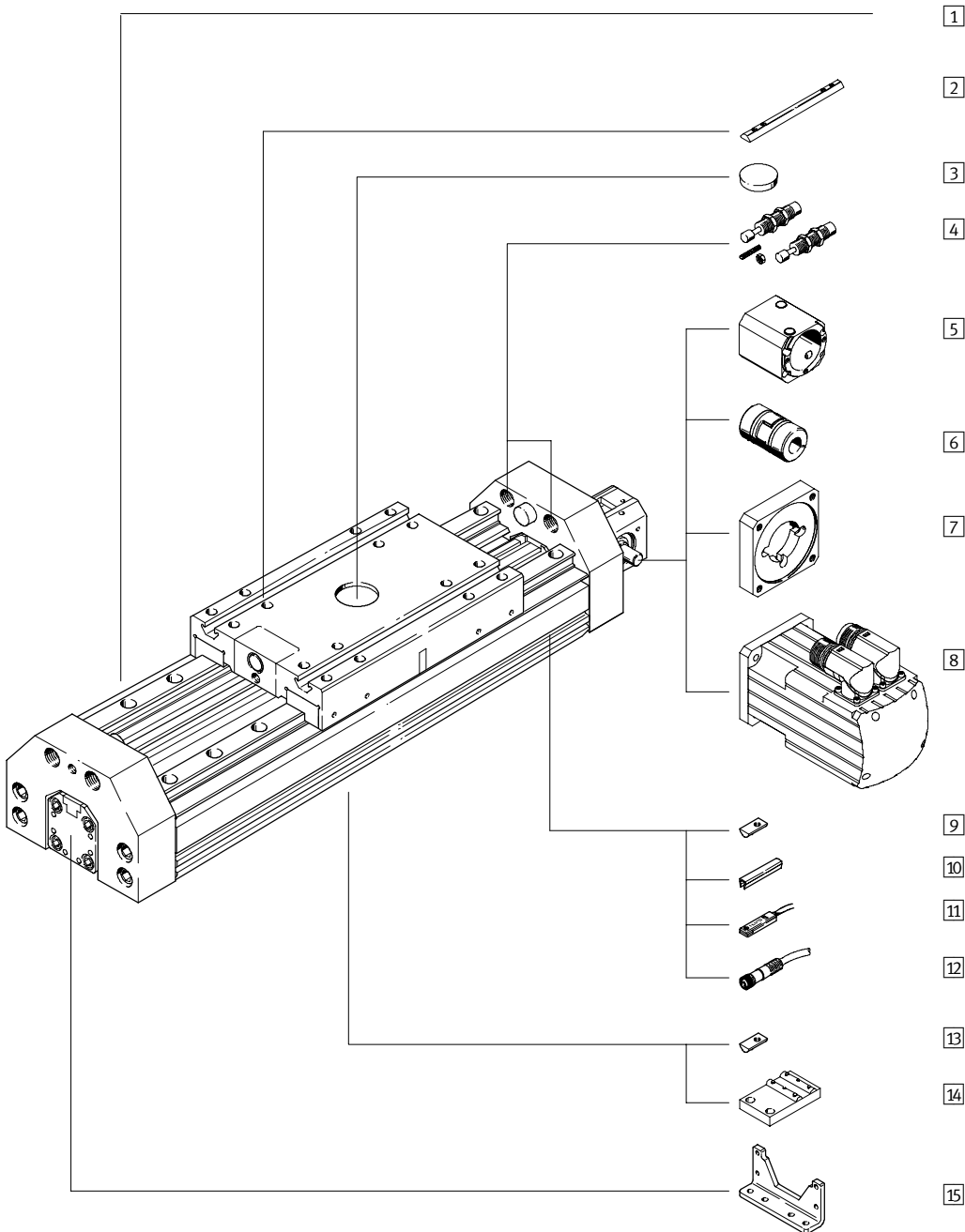

Toothed belt axes DGE-ZR-HD, with heavy-duty guide

Peripherals overview

Variants and accessories		
Type	Brief description	→ Page
1 Toothed belt axis DGE-ZR-HD	Electromechanical axis with heavy-duty guide	5 / 2.1-64
2 Slot nut for slide X	For mounting loads and attachments on the slide	5 / 2.1-87
3 Central mounting Q	For centring loads and attachments on the slide	5 / 2.1-87
4 Shock absorber kits D	For avoiding damage at the end stop in the event of malfunction	5 / 2.1-86
5 Coupling housing KG	Adapter for mounting the motor on the axis	5 / 2.1-78
6 Coupling KSE	Connecting element between axis and motor	5 / 2.1-78
7 Motor flange MTR-FL	Connecting element between coupling housing and motor	5 / 2.1-78
8 Motor MTR	Motors specially matched to the axis, with or without gearing, with or without brake	5 / 2.1-78
9 Slot nut for profile slot Y	For mounting attachments	5 / 2.1-87
10 Slot cover B/S	For protecting against dirt	5 / 2.1-87
11 Proximity sensor G/H/I/J/N	For use as a signal or safety check	5 / 2.1-90
12 Plug socket with cable V	For proximity sensors	5 / 2.1-90
13 Slot nut for HD underneath U	For mounting attachments	5 / 2.1-87
14 Central support M	For mounting the axis	5 / 2.1-83
15 Foot mounting F	For mounting the axis	5 / 2.1-83

Toothed belt axes DGE-ZR-HD, with heavy-duty guide

Type code

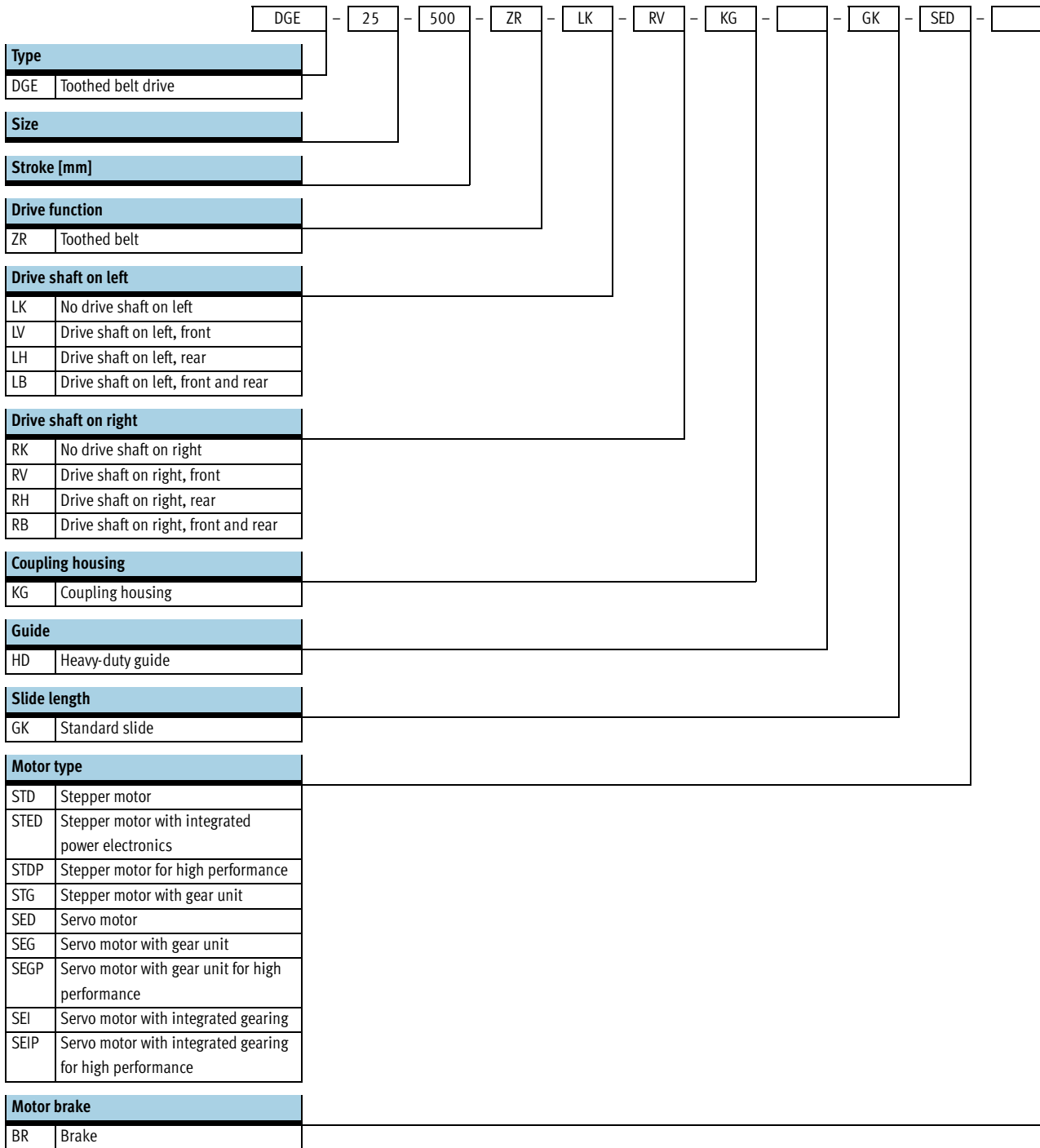

Toothed belt axes DGE-ZR-HD, with heavy-duty guide

Type code

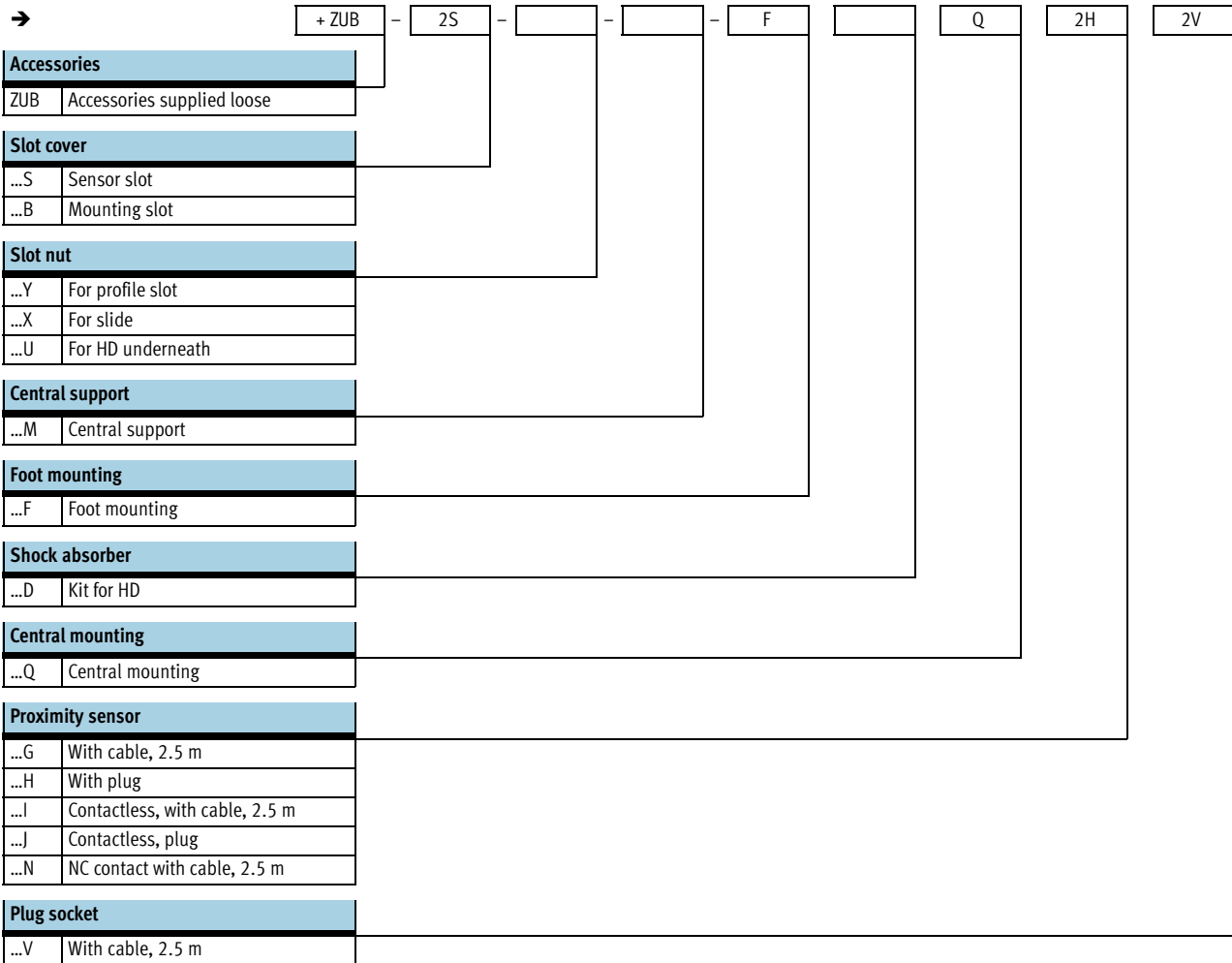

Toothed belt axes DGE-ZR-HD, with heavy-duty guide

Technical data



- - Size
18 ... 40
- - Stroke length
1 ... 2000 mm

- - www.festo.com/en/Spare_parts_service

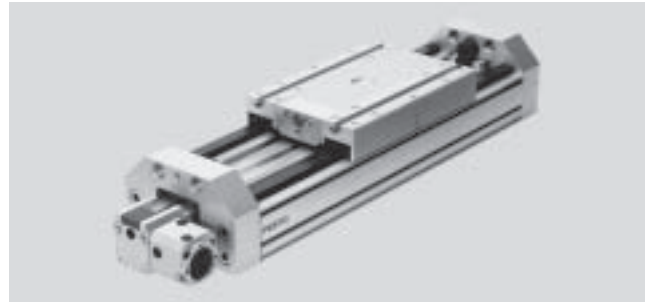

General technical data				
Size	18-HD18	25-HD25	25-HD40	40-HD40
Constructional design	Electromechanical axis with heavy-duty guide			
Guide	Recirculating ball bearing guide			
Mounting position	Any			
Max. working stroke [mm]	1 ... 1000	1 ... 2000	1 ... 2000	1 ... 2000
Max. working load [kg]	4.2	18	16	48
Max. feed force F_x [N]	60	260	260	610
Max. driving torque [Nm]	0.5	2.6	2.6	9.7
Max. no-load driving torque ¹⁾ [Nm]	0.2	0.5	0.5	1
Max. speed [m/s]	3			
Repetition accuracy [mm]	±0.08	±0.1		

1) Measured at a speed of 0.2 m/s

Operating and environmental conditions				
Size	18-HD18	25-HD25	25-HD40	40-HD40
Ambient temperature [°C]	-10 ... +40			
Protection class	IP40			

Weights [kg]				
Size	18-HD18	25-HD25	25-HD40	40-HD40
Basic weight with 0 mm stroke ¹⁾	3.812	5.63	14.33	17.75
Additional weight per 100 mm stroke	0.883	1.51	2.1	2.42

1) Including coupling housing and slide

Mass moment of inertia				
Size	18-HD18	25-HD25	25-HD40	40-HD40
J_0 [kg cm ²]	0.372	2.32	4.23	12
J_H per metre stroke [kg cm ² /m]	0.021	0.078	0.078	0.45
J_L per kg working load [kg cm ² /kg]	0.685	1	1	2.53

The mass moment of inertia J_A of the entire axis is calculated as follows:

$$J_A = J_0 + J_H \times \text{working stroke [m]} + J_L \times m_{\text{working load [kg]}}$$

Toothed belt axes DGE-ZR-HD, with heavy-duty guide

Technical data

Toothed belt					
Size		18-HD18	25-HD25	25-HD40	40-HD40
Tensile stress ¹⁾	[%]	0.2	0.11	0.11	0.1
Pitch	[mm]	2	3	3	5
Effective radius; effective diameter	[mm]	16.55	20.05	20.05	31.83
Feed constant	[mm]	52	63	63	100

1) At max. feed force

Materials

Sectional view

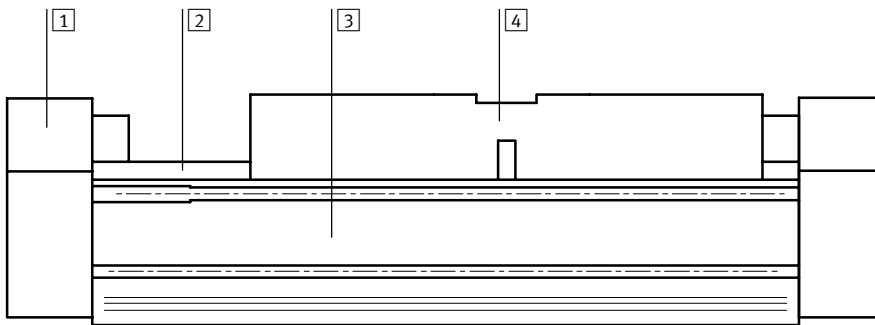

Axis		
1	End cap	Anodised aluminium
2	Guide	Rolled steel
3	Profile	Anodised aluminium
4	Slide	Anodised aluminium

Toothed belt axes DGE-ZR-HD, with heavy-duty guide

Technical data



Characteristic load values

The indicated forces and torques refer to the centre of the heavy-duty guide.

They must not be exceeded in the dynamic range. Special attention must be paid to the cushioning phase.

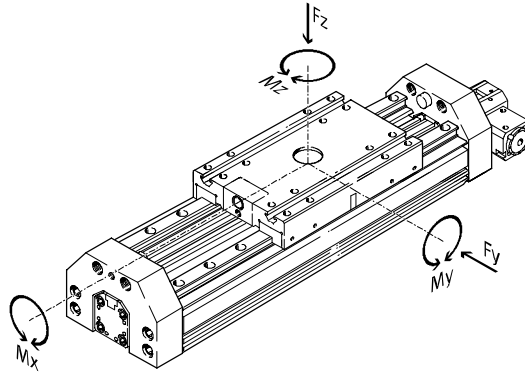

If the drive is subjected to more than two of the indicated forces and torques simultaneously, the following equations must be satisfied in addition to the indicated maximum loads.

$$\frac{F_y}{F_{y_{max}}} + \frac{F_z}{F_{z_{max}}} + \frac{M_x}{M_{x_{max}}} + \frac{M_y}{M_{y_{max}}} + \frac{M_z}{M_{z_{max}}} \leq 1$$

Permissible forces and torques

Size		18-HD18	25-HD25	25-HD40	40-HD40
F _y _{max.}	[N]	1820	5400	5400	5400
F _z _{max.}	[N]	1820	5600	5600	5600
M _x _{max.}	[Nm]	70	260	260	375
M _y _{max.}	[Nm]	115	415	415	560
M _z _{max.}	[Nm]	112	400	400	540



Design tool

PtTool

www.festo.com/en/engineering

Toothed belt axes DGE-ZR-HD, with heavy-duty guide

Technical data

Maximum permissible support span l as a function of the force F

The axis may need to be supported with central supports MUP in order to restrict deflection with long stroke lengths. The following diagrams serve to determine the maximum permissible support span l as a function of the force acting upon the axis F .

Force on the surface of the slide

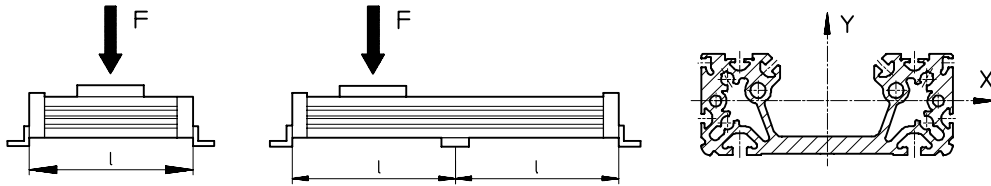

Maximum permissible support span l (without central support) as a function of the force F

Deflection around the X axis

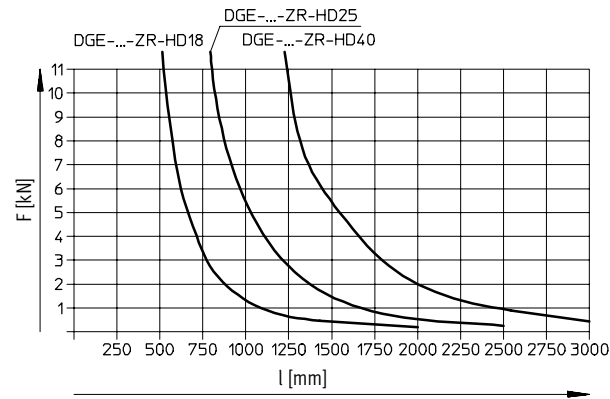

Deflection around the Y axis

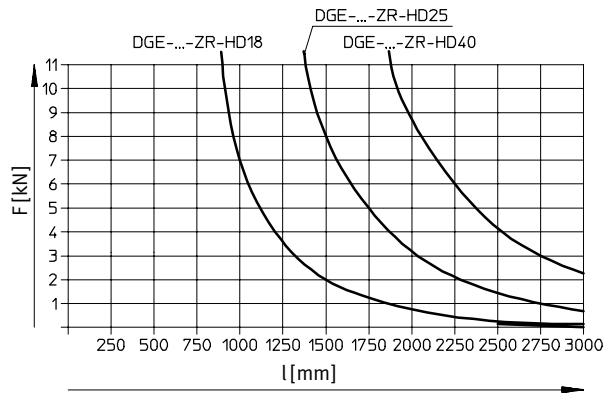

Toothed belt axes DGE-ZR-HD, with heavy-duty guide

Technical data



Maximum permissible acceleration a as a function of the effective load m

DGE-18-...-ZR-HD18

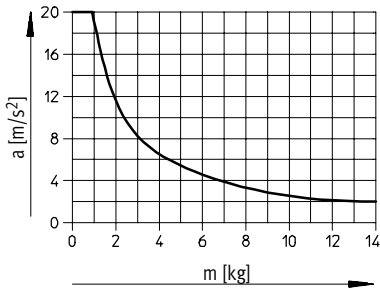

DGE-25-...-ZR-HD25

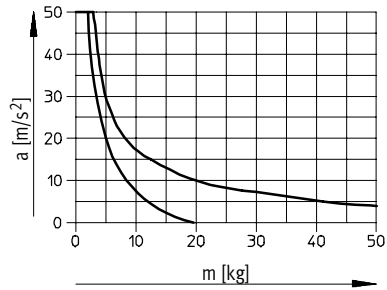

DGE-25-...-ZR-HD40

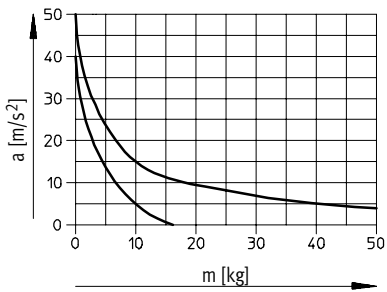

DGE-40-...-ZR-HD40

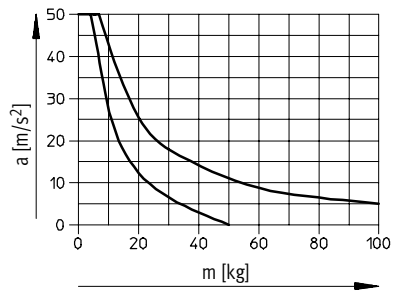

- - - vertical
— horizontal

Toothed belt axes DGE-ZR-HD, with heavy-duty guide

Technical data



Dimensions

Download CAD data → www.festo.com/en/engineering

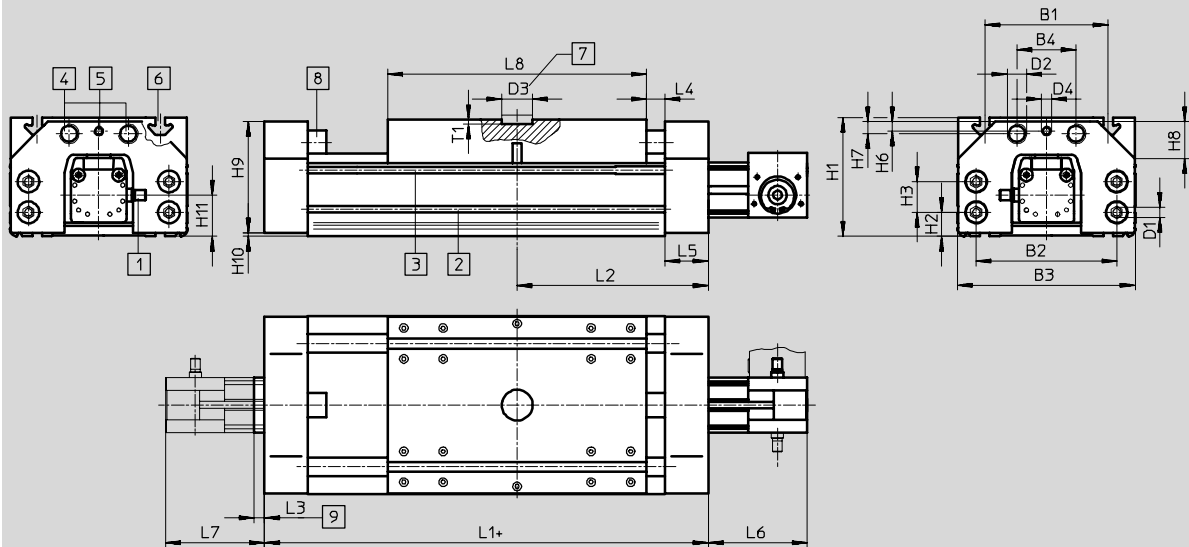

- | | | | |
|------------------------------------|-----------------------------------|--|------------------------|
| 1 Drive spigot | 4 Thread for shock absorber | 7 Hole for central mounting SLZZ | + = plus stroke length |
| 2 Mounting slot for slot nut NST | 5 Thread for threaded pin | 8 Rubber buffer | |
| 3 Sensor slot for proximity sensor | 6 Mounting slot for slot nut NSTH | 9 Dimension for motor connection on one side | |

Profile

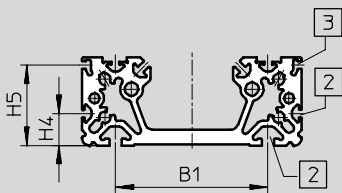

- | | |
|---|----------------------------------|
| 2 | Mounting slot for slot nut NST |
| 3 | Sensor slot for proximity sensor |

Size	B1	B2	B3	B4	D1	D2	D3	D4	H1	H2	H3	H4	H5	H6
18-HD-18	80	85	116 ±0,2	40	M5	M12x1	25	M6	70	12.8	19.5±0,1	14	42.3	5.9
25-HD-25	100	114	144	48	M8	M16x1	25	M8	93.5	18.5	25±0,2	21	52.8	9
25-HD-40	140	156	185	54	M8	M22x1.5	25	M8	124.5	21	48±0,2	35	82.8	5.5
40-HD-40	140	156	185	54	M8	M22x1.5	25	M8	124.5	21	48±0,2	35	82.8	5.5

Size	H7	H8	H9	H10	H11	L1	L2	L3	L4	L5	L6	L7	L8	T1
18-HD-18	8.7	20x45°	68	0.8	24.9	240	120	–	15	25	70	59	160	3.5
25-HD-25	9.8	30x45°	90	2	28.9	310	155	–	15	35	80	61	210	3.5
25-HD-40	15.5	35x45°	120	2	54.9	354	177	–	15	32	82	63	260	4
40-HD-40	15.5	35x45°	120	2	42.5	354	177	15	15	32	109	82	260	4

Toothed belt axes DGE-ZR-HD, with heavy-duty guide

Ordering data – Modular products



Order code

Mandatory data

- LK No drive shaft on left
- LV Drive shaft on left, front
- LH Drive shaft on left, rear
- LB Drive shaft on left, front and rear
- RK No drive shaft on right
- RV Drive shaft on right, front
- RH Drive shaft on right, rear
- RB Drive shaft on right, front and rear

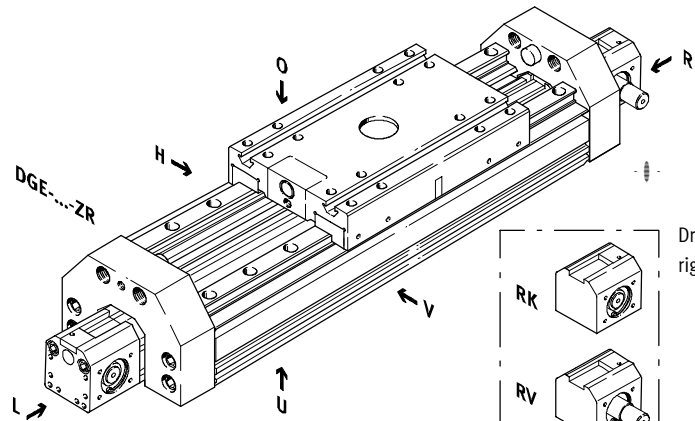

Drive shaft left

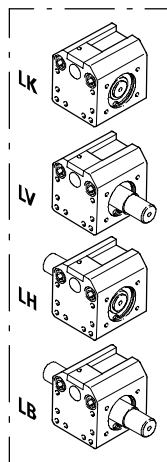

Drive shaft right

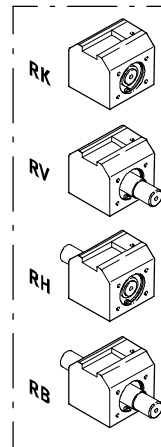

- - Note

The insertion point for the proximity sensor is located on the right side of the heavy-duty guide.

O top
U underneath
R right
L left
V front
H rear

Toothed belt axes DGE-ZR-HD, with heavy-duty guide

Ordering data – Modular products



Order code

Options

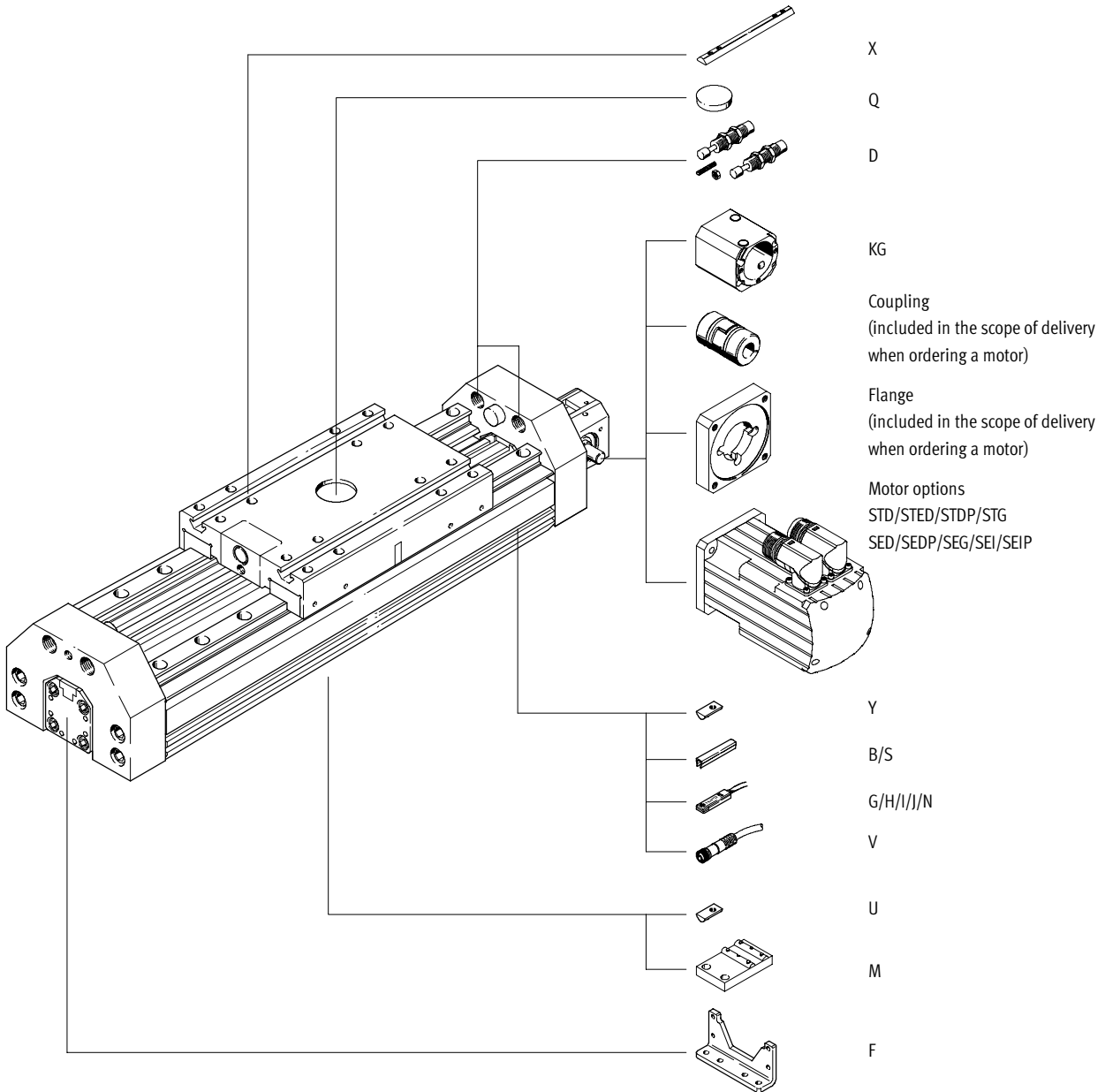

Toothed belt axes DGE-ZR-HD, with heavy-duty guide

Ordering data – Modular products



Mandatory data							Options		
Module No.	Design	Size	Stroke	Drive function	Drive shaft on left	Drive shaft on right	Coupling housing	Guide	Slide
193 741	DGE	18	1 ... 2000	ZR	LK	RK	KG	HD18	GK
193 742		25			LV	RV		HD25	
193 743		40			LH	RH		HD40	
Ordering example									
193 742	DGE	- 25	- 800	- ZR	- LK	- RV	- KG	- HD40	- GK

Ordering table										
Size	18	25	40	Condi- tions	Code	Enter code				
M	Module No.	193 741	193 742	193 743						
	Design	Electromechanical linear axis				DGE	DGE			
	Size	18	25	40		-...				
	Stroke [mm]	1 ... 1000	1 ... 2000	1 ... 2000		-...				
	Drive function	Electromechanical drive with toothed belt				-ZR	-ZR			
	Drive shaft on left	No drive shaft on left			1	-LK				
		Drive shaft on left, front				-LV				
		Drive shaft on left, rear				-LH				
		Drive shaft on left, front and rear				-LB				
	Drive shaft on right	No drive shaft on right			2	-RK				
		Drive shaft on right, front				-RV				
		Drive shaft on right, rear				-RH				
		Drive shaft on right, front and rear				-RB				
	O	Coupling housing	Coupling housing				-KG			
	Guide	Heavy-duty guide HD18		-	-	-HD18	-HD...			
		-	Heavy-duty guide HD25		-	-	-HD25			
		-	Heavy-duty guide HD40		Heavy-duty guide HD40		-HD40			
	Slide	Standard				-GK	-GK			

1 LK Not with drive shaft on right RK.

2 RK Not with drive shaft on left LK.

Transfer order code

	DGE	-		-	ZR	-		-		-	HD...	-	GK
--	-----	---	--	---	----	---	--	---	--	---	-------	---	----

Toothed belt axes DGE-ZR-HD, with heavy-duty guide

Ordering data – Modular products

Options	
<p>Motor type</p> <p>STD STDP STG SED SEDP SEG SEI SEIP</p> <p>- STD</p>	<p>Brake</p> <p>BR</p> <p>- BR</p>

Ordering table						
Size	18	25	40	Condi- tions	Code	Enter code
↓ Motor type [0] Stepper motor Servo motor ↓ Brake	Stepper motor		–	[3]	-STD	
	–	for high performance	–	[3]	-STDP	
	–	–	with gear unit	[3]	-STG	
	Servo motor		–	[3]	-SED	
	–	–	for high performance	[3]	-SEDP	
	–	with gear unit	–	[3]	-SEG	
	–	–	with integrated gearing	[3]	-SEI	
	–	–	with integrated gearing for high performance	[3]	-SEIP	
	Motor brake	–	–	[4]	-BR	

[3] **Motor type** Only with coupling housing KG.

[4] **BR** Only permissible with motor type.

Allocation of order codes to motor types → from 5 / 2.1-78	The motor controller and cable set must be ordered separately. Stepper motor → 5 / 2.2-2 Servo motor → 5 / 2.2-16
---	---

Transfer order code

– –

Toothed belt axes DGE-ZR-HD, with heavy-duty guide

Ordering data – Modular products



Options								
Accessories	Slot cover	Slot nut	Central support	Foot mounting	Shock absorber	Central mounting	Proximity sensor	Plug socket
ZUB	...S ...B	...Y ...X ...U	...M	...F	...D	...Q	...G ...H ...I ...J ...N	...V
ZUB	2S2B	10U		F		2Q	2H	2V

Ordering table							
Size		18	25	40	Condi- tions	Code	Enter code
↓	Accessories	Supplied separately				ZUB-	ZUB-
0	Slot cover	Sensor slot	1 ... 10			...S	
		Mounting slot	1 ... 10			...B	
	Slot nut	for mounting slot	1 ... 10			...Y	
		for slide	1 ... 10			...X	
		for HD underneath	1 ... 10			...U	
	Central support	1 ... 10				...M	
	Foot mounting (kit)	1 ... 10				...F	
	Shock absorber Kit for HD	1 ... 2				...D	
	Central mounting	1 ... 10				...Q	
	Proximity sensor	with cable 2.5 m	1 ... 10			...G	
		with plug	1 ... 10			...H	
		contactless with cable 2.5 m	1 ... 10			...I	
		contactless, plug	1 ... 10			...J	
		NC contact with cable 2.5 m	1 ... 10			...N	
	Plug socket with cable 2.5 m	1 ... 10				...V	

Transfer order code

ZUB -

Toothed belt axes DGE-ZR-HD, with heavy-duty guide

Application example

FESTO

Planar surface gantry

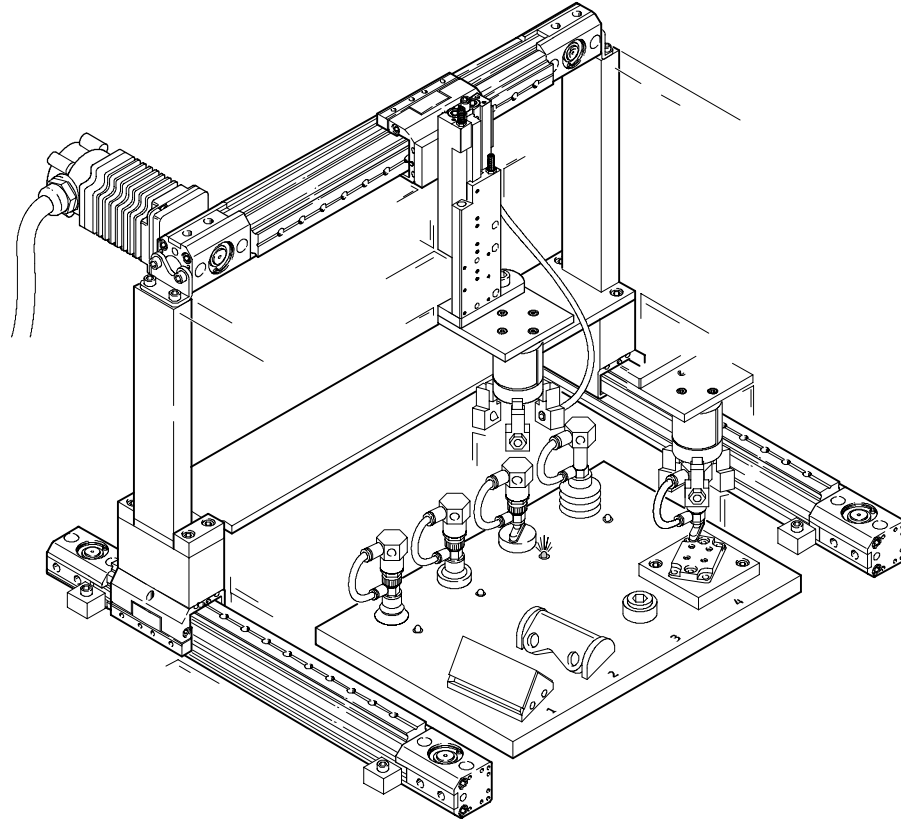

Toothed belt axes DGE

Accessories







Permissible axis and servo motor combinations								
Axis	Servo motor		Motor flange		Coupling		Coupling housing	
DGE-ZR DGE-ZR-KF DGE-ZR-HD								
Order code	Part No.	Type	Part No.	Type	Part No.	Type	Part No.	Type
For DGE-12								
	without gearing/without brake							
SEDP	526 723	MTR-AC-55-3S-AA	534 807	MTR-FL30-AC55	184 262	KSE-15-D04-D09	171 185	DGE-KG-12-ZR-FL30
	without gearing/with brake							
SEDP + BR	526 724	MTR-AC-55-3S-AB	534 807	MTR-FL30-AC55	184 262	KSE-15-D04-D09	171 185	DGE-KG-12-ZR-FL30
For DGE-18								
	without gearing/without brake							
SED	526 723	MTR-AC-55-3S-AA	529 942	MTR-FL44-AC55	184 263	KSE-19-D06-D09	170 375	DGE-KG-18-ZR-FL44
	without gearing/with brake							
SED + BR	526 724	MTR-AC-55-3S-AB	529 942	MTR-FL44-AC55	184 263	KSE-30-D06-D09	170 375	DGE-KG-18-ZR-FL44
For DGE-25								
	without gearing/without brake							
SED	526 727	MTR-AC-70-3S-AA	529 943	MTR-FL44-AC70	123 042	KSE-30-D08-D11	124 628	DGE-KG-25-ZR-FL44
	without gearing/with brake							
SED + BR	526 728	MTR-AC-70-3S-AB	529 943	MTR-FL44-AC70	123 042	KSE-30-D08-D11	124 628	DGE-KG-25-ZR-FL44
	with gearing/without brake							
SEG	526 729	MTR-AC-70-3S-GA	529 943	MTR-FL44-AC70	123 043	KSE-30-D08-D12	124 628	DGE-KG-25-ZR-FL44
	with gearing/with brake							
SEG + BR	526 730	MTR-AC-70-3S-GB	529 943	MTR-FL44-AC70	123 043	KSE-30-D08-D12	124 628	DGE-KG-25-ZR-FL44
For DGE-40								
	without gearing/without brake							
SED	526 731	MTR-AC-100-3S-AA	529 947	MTR-FL64-AC100	176 033	KSE-40-D15-D24	124 629	DGE-KG-40-ZR-FL64
SEDP	526 735	MTR-AC-100-5S-AA	529 947	MTR-FL64-AC100	176 033	KSE-40-D15-D24	124 629	DGE-KG-40-ZR-FL64
	without gearing/with brake							
SED + BR	526 732	MTR-AC-100-3S-AB	529 947	MTR-FL64-AC100	176 033	KSE-40-D15-D24	124 629	DGE-KG-40-ZR-FL64
SEDP + BR	526 736	MTR-AC-100-5S-AB	529 947	MTR-FL64-AC100	176 033	KSE-40-D15-D24	124 629	DGE-KG-40-ZR-FL64
	with integrated gearing/without brake							
SEI	526 733	MTR-AC-100-3S-GA	529 947	MTR-FL64-AC100	176 033	KSE-40-D15-D24	124 629	DGE-KG-40-ZR-FL64
SEIP	526 737	MTR-AC-100-5S-GA	529 947	MTR-FL64-AC100	176 033	KSE-40-D15-D24	124 629	DGE-KG-40-ZR-FL64
	with integrated gearing/with brake							
SEI + BR	526 734	MTR-AC-100-3S-GB	529 947	MTR-FL64-AC100	176 033	KSE-40-D15-D24	124 629	DGE-KG-40-ZR-FL64
SEIP + BR	526 738	MTR-AC-100-5S-GB	529 947	MTR-FL64-AC100	176 033	KSE-40-D15-D24	124 629	DGE-KG-40-ZR-FL64
For DGE-63								
	with integrated gearing/without brake							
SEI	526 737	MTR-AC-100-5S-GA	529 949	MTR-FL118-AC100	123 852	KSE-65-D24-D25	124 630	DGE-KG-63-ZR-FL118
	with integrated gearing/with brake							
SEI + BR	526 738	MTR-AC-100-5S-GB	529 949	MTR-FL118-AC100	123 852	KSE-65-D24-D25	124 630	DGE-KG-63-ZR-FL118

- - Note
 The reduction ratio of the gearing is Technical data for servo motors
 4 : 1. → 5 / 2.2-16

Toothed belt axes DGE

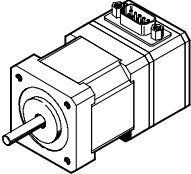
Accessories



Permissible axis and stepper motor combinations								
Axis	Stepper motor		Motor flange		Coupling		Coupling housing	
DGE-ZR DGE-ZR-KF DGE-ZR-HD								
Order code	Part No.	Type	Part No.	Type	Part No.	Type	Part No.	Type
For DGE-8								
	without gearing/without brake							
STD	530 057	MTR-ST-42-48S-AA	530 080	MTR-FL28-ST42	530 084	KSE-15-D04-D05	171 186	DGE-KG-8-ZR-FL28
STED	530 059	MTRE-ST-42-48S-AA	530 080	MTR-FL28-ST42	530 084	KSE-15-D04-D05	171 186	DGE-KG-8-ZR-FL28
	without gearing/with brake							
STD + BR	530 058	MTR-ST-42-48S-AB	530 080	MTR-FL28-ST42	530 084	KSE-15-D04-D05	171 186	DGE-KG-8-ZR-FL28
STED + BR	530 060	MTRE-ST-42-48S-AB	530 080	MTR-FL28-ST42	530 084	KSE-15-D04-D05	171 186	DGE-KG-8-ZR-FL28
For DGE-12								
	without gearing/without brake							
STD	530 057	MTR-ST-42-48S-AA	530 079	MTR-FL30-ST42	530 084	KSE-15-D04-D05	171 185	DGE-KG-12-ZR-FL30
STED	530 059	MTRE-ST-42-48S-AA	530 079	MTR-FL30-ST42	530 084	KSE-15-D04-D05	171 185	DGE-KG-12-ZR-FL30
	without gearing/with brake							
STD + BR	530 058	MTR-ST-42-48S-AB	530 079	MTR-FL30-ST42	530 084	KSE-15-D04-D05	171 185	DGE-KG-12-ZR-FL30
STED + BR	530 060	MTRE-ST-42-48S-AB	530 079	MTR-FL30-ST42	530 084	KSE-15-D04-D05	171 185	DGE-KG-12-ZR-FL30
For DGE-18								
	without gearing/without brake							
STD	530 061	MTR-ST-57-48S-AA	530 081	MTR-FL44-ST57	530 086	KSE-19-D06-D06,35	170 375	DGE-KG-18-ZR-FL44
	without gearing/with brake							
STD + BR	530 062	MTR-ST-57-48S-AB	530 081	MTR-FL44-ST57	530 086	KSE-19-D06-D06,35	170 375	DGE-KG-18-ZR-FL44
For DGE-25								
	without gearing/without brake							
STD	530 061	MTR-ST-57-48S-AA	530 081	MTR-FL44-ST57	530 088	KSE-30-D06,35-D08	124 628	DGE-KG-25-ZR-FL44
STDP	530 065	MTR-ST-87-48S-AA	530 082	MTR-FL44-ST87	123 042	KSE-30-D08-D11	124 628	DGE-KG-25-ZR-FL44
	without gearing/with brake							
STD + BR	530 062	MTR-ST-57-48S-AB	530 081	MTR-FL44-ST57	530 088	KSE-30-D06,35-D08	124 628	DGE-KG-25-ZR-FL44
STDP + BR	530 066	MTR-ST-87-48S-AB	530 082	MTR-FL44-ST87	123 042	KSE-30-D08-D11	124 628	DGE-KG-25-ZR-FL44
For DGE-40								
	with gearing/without brake							
STG	530 067	MTR-ST-87-48S-GA	533 139	MTR-FL64-PL80	123 845	KSE-40-D15-D20	124 629	DGE-KG-40-ZR-FL64
	with gearing/with brake							
STG + BR	530 068	MTR-ST-87-48S-GB	533 139	MTR-FL64-PL80	123 845	KSE-40-D15-D20	124 629	DGE-KG-40-ZR-FL64



-  - Note

The reduction ratio of the gearing is 4 : 1. Technical data for stepper motors → 5 / 2.2-16

Toothed belt axes DGE

Accessories

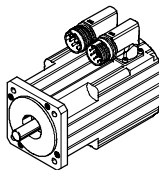
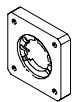
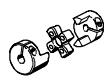

Permissible axis and servo motor combinations								
	Servo motor		Flange		Coupling		Coupling housing	
DGE-ZR-RF								
Order code	Part No.	Type	Part No.	Type	Part No.	Type	Part No.	Type
For DGE-25-ZR-RF								
	without gearing/without brake							
SED	526 727	MTR-AC-70-3S-AA	529 943	MTR-FL-44-AC70	123 042	KSE-30-D08-D11	534 394	DGE-KG-25-ZR-RF-FL44
	without gearing/with brake							
SED + BR	526 728	MTR-AC-70-3S-AB	529 943	MTR-FL-44-AC70	123 042	KSE-30-D08-D11	534 394	DGE-KG-25-ZR-RF-FL44
	with gearing/without brake							
SEG	526 725	MTR-AC-55-3S-GA	529 944	MTR-FL-44-PL60	123 042	KSE-30-D08-D11	534 394	DGE-KG-25-ZR-RF-FL44
SEGP	526 729	MTR-AC-70-3S-GA	529 943	MTR-FL-44-AC70	123 043	KSE-30-D08-D12	534 394	DGE-KG-25-ZR-RF-FL44
	with gearing/with brake							
SEG + BR	526 726	MTR-AC-55-3S-GB	529 944	MTR-FL-44-PL60	123 042	KSE-30-D08-D11	534 394	DGE-KG-25-ZR-RF-FL44
SEGP + BR	526 730	MTR-AC-70-3S-GB	529 943	MTR-FL-44-AC70	123 043	KSE-30-D08-D12	534 394	DGE-KG-25-ZR-RF-FL44
For DGE-40-ZR-RF								
	without gearing/without brake							
SED	526 735	MTR-AC-100-5S-AA	529 947	MTR-FL-64-AC100	123 844	KSE-40-D15-D19	534 395	DGE-KG-40-ZR-RF-FL64
	without gearing/with brake							
SED + BR	526 736	MTR-AC-100-5S-AB	529 947	MTR-FL-64-AC100	123 844	KSE-40-D15-D19	534 395	DGE-KG-40-ZR-RF-FL64
	with integrated gearing/without brake							
SEI	526 733	MTR-AC-100-3S-GA	529 947	MTR-FL-64-AC100	176 033	KSE-40-D15-D24	534 395	DGE-KG-40-ZR-RF-FL64
	with integrated gearing/with brake							
SEI + BR	526 734	MTR-AC-100-3S-GB	529 947	MTR-FL-64-AC100	176 033	KSE-40-D15-D24	534 395	DGE-KG-40-ZR-RF-FL64
For DGE-63-ZR-RF								
	with integrated gearing/without brake							
SEI	526 733	MTR-AC-100-3S-GA	529 949	MTR-FL-118-AC100	123 852	KSE-65-D25-D24	534 396	DGE-KG-63-ZR-RF-FL118
SEIP	526 737	MTR-AC-100-5S-GA	529 949	MTR-FL-118-AC100	123 852	KSE-65-D25-D24	534 396	DGE-KG-63-ZR-RF-FL118
	with integrated gearing/with brake							
SEI + BR	526 734	MTR-AC-100-3S-GB	529 949	MTR-FL-118-AC100	123 852	KSE-65-D25-D24	534 396	DGE-KG-63-ZR-RF-FL118
SEIP + BR	526 738	MTR-AC-100-5S-GB	529 949	MTR-FL-118-AC100	123 852	KSE-65-D25-D24	534 396	DGE-KG-63-ZR-RF-FL118

 Note

The reduction ratio of the gearing is
4 : 1.

Technical data for servo motors
→ 5 / 2.2-16

Toothed belt axes DGE

Accessories



Foot mounting HP
(order code F)

Material:
Galvanised steel
Free of copper, PTFE and silicone



HP-25

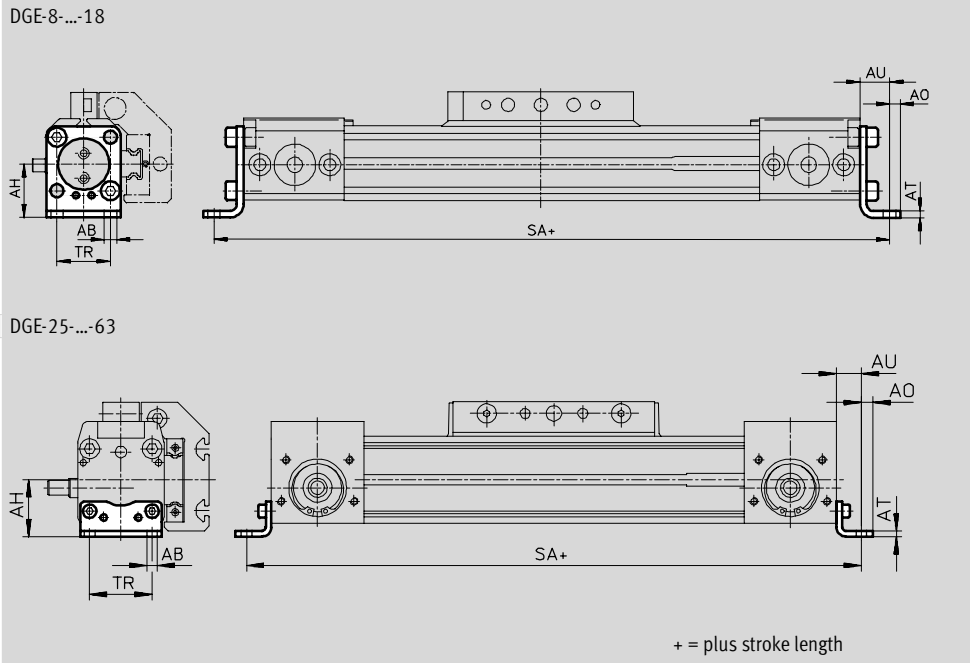

Dimensions and ordering data						
for size	AB ∅	AH	AO	AT	AU	TR
8	3.4	13.8	3	2	9	13
12	3.4	16.5	3	2	9	18.6
18	5.5	24	4.8	3	13.3	24
25	5.5	29.5	6	3	13	32.5
40	6.6	46	8.5	5	17.5	45
63	11	69	13.5	6	28	75

for size	SA				Weight [g]	Part No.	Type
	for DGE-ZR/DGE-ZR-KF		for DGE-ZR-RF				
	GK	GV	GK	GV			
8	198	-	-	-	17	158 470	HP-8
12	234	-	-	-	23	158 471	HP-12
18	308.6	388.6	-	-	70	158 472	HP-18
25	398	498	440	535	61	150 731	HP-25
40	604	774	673	813	188	150 733	HP-40
63	938	1188	1076	1306	305	150 735	HP-63

Core Range

Toothed belt axes DGE

Accessories



Central support MUP
(order code M)

Material:
Galvanised steel
Free of copper, PTFE and silicone



MUP-40

DGE-8-...-25

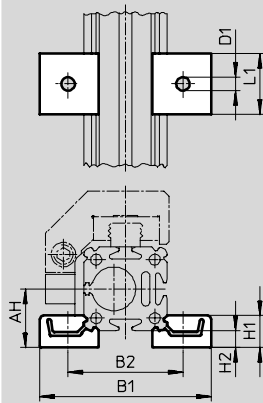

DGE-40-...-63

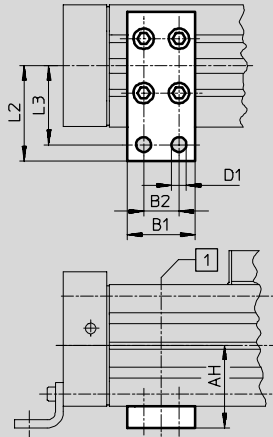

1 Position of the central support along the profile is freely selectable

Dimensions and ordering data

for size	AH	B1	B2	D1 ∅	H1	H2	L1	L2	L3	Weight [g]	Part No.	Type
8	13.8	40.5	28.5	3.5	8	4	15	-	-	8	160 909	MUP-8/12
12	16.5	46	34	3.5	8	4	15	-	-	8	160 909	MUP-8/12
18	24	70.5	47	5.5	13	7	25	-	-	33	150 736	MUP-18/25
25	29.5	81	58	5.5	13	7	25	-	-	33	150 736	MUP-18/25
40	46	35	22	6.6	-	-	-	47	40	126	150 738	MUP-40
63	69	50	26	11	-	-	-	77	65	340	150 800	MUP-63

Core Range

Toothed belt axes DGE

Accessories



Foot mounting HHP

for heavy-duty guide

(order code F)

Material:

Galvanised steel



Central support MUP

for heavy-duty guide

(order code M)

Material:

Galvanised steel

Free of copper, PTFE and silicone

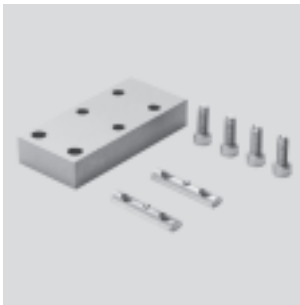

DGE-...-HD18/-HD25/-HD40

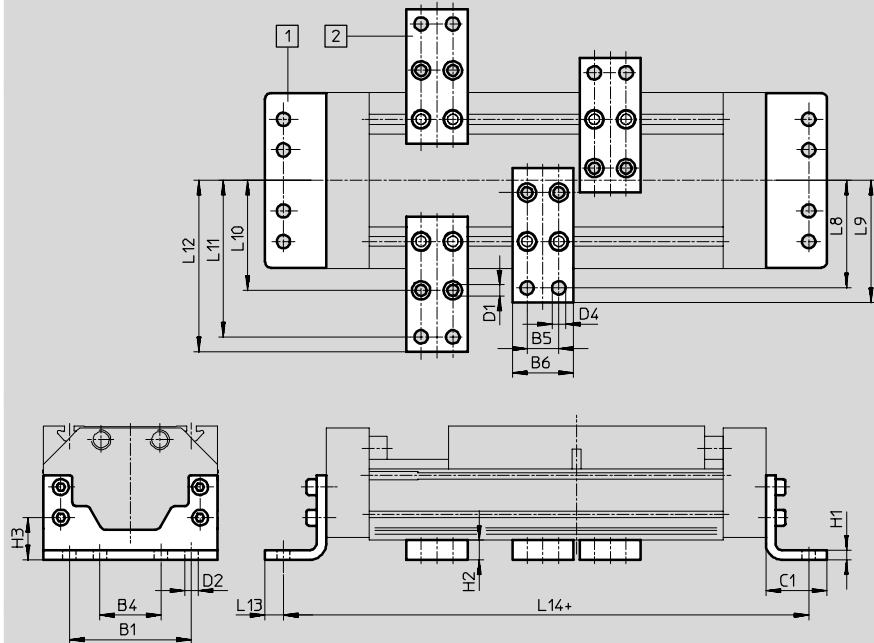

- 1 Foot mounting HHP
- 2 Central support MUP

+ = plus stroke length

Dimensions and ordering data											
for heavy-duty guide	B1	B4	B5	B6	C1	D1	D2	D4	H1	H2	H3
HD18	80	40	22	35	34	5.5	6.6	6.6	8	14	26.8
HD25	100	50	26	50	50	9	11	11	8	16	34.5
HD40	140	70	26	50	50	9	11	11	10	16	37

for heavy-duty guide	L8	L9	L10	L11	L12	L13	L14	Weight [g]	Part No.	Type
HD18	68	75	64	92	99	9	290	357	161 993	HHP-18
								126	150 738	MUP-40
HD25	88	100	90	128	140	15	380	794	161 994	HHP-25
								347	150 739	MUP-50
HD40	108	120	110	148	160	15	424	1318	161 995	HHP-40
								347	150 739	MUP-50

Core Range

Toothed belt axes DGE

Accessories

Shock absorber YSR-...-C

(order code C)

Material:

Housing: galvanised steel; piston rod:

high-alloy steel,

seals: perbunan, polyurethane

Free of copper, PTFE and silicone



Note

Shock absorber YSRW with progressive characteristics

➔ Volume 1

Ordering data			
for size	Weight [g]	Part No.	Type
8	9	158 981	YSR-5-5-C
12	9	158 981	YSR-5-5-C
18	30	34 571	YSR-8-8-C
25	70	34 572	YSR-12-12-C
40	140	34 573	YSR-16-20-C
63	240	34 574	YSR-20-25-C

Shock absorber retainer KYP

(order code C)

Material:

Retainer: Aluminium

Sleeve: Corrosion resistant steel

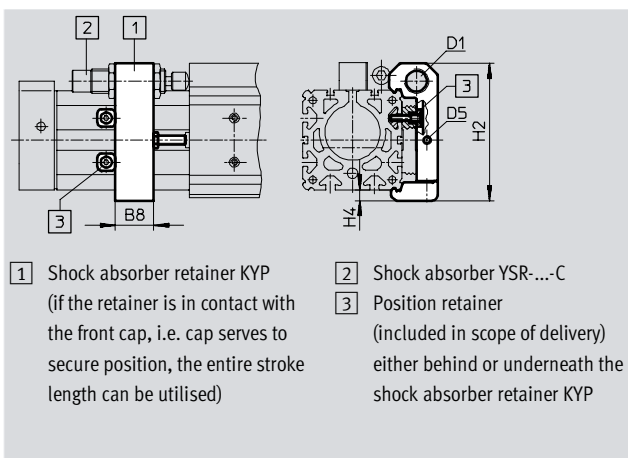

Dimensions and ordering data								
for size	B8	D1	D5	H2	H4	Weight [g]	Part No.	Type
8	8	M8x1	M3	31.5	3	36	158 905	KYP-8
12	11	M8x1	M4	37	3	44	158 906	KYP-12
18	14	M12x1	M4	50.5	4.5	66	158 907	KYP-18
25	19	M16x1	M5	69.5	6	95	158 908	KYP-25
40	32	M22x1.5	M5	102	8	209	158 910	KYP-40
63	44	M26x1.5	M10	152.5	11.5	609	158 912	KYP-63

Core Range

Toothed belt axes DGE

Accessories



Emergency buffer NPE (order code A)

Material:
Polyurethane

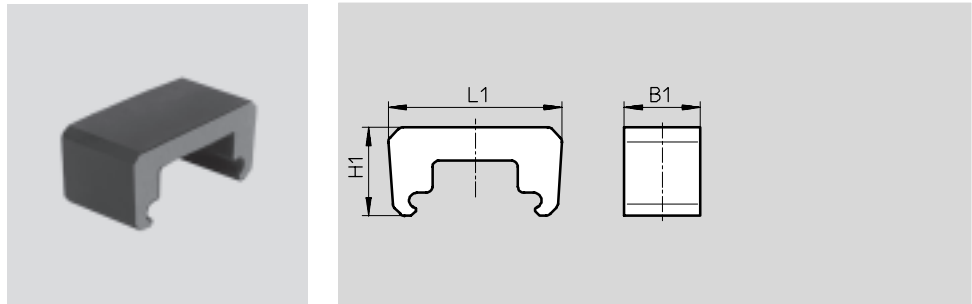

Dimensions and ordering data						
for size	B1	L1	H1	Weight [g]	Part No.	Type
18	15	43.1	28.5	6	193 901	NPE-18
25	25	57	29	12	193 902	NPE-25
40	40	80.5	36	41	193 904	NPE-40
63	60	128.6	55	152	193 906	NPE-63

 Note
The emergency buffer can only be used in conjunction with shock absorber retainer KYP. → 5 / 2.1-84 (A threaded pin and nut are not required.)

Shock absorber DG-GA for protected version GA (order code E)

Material:
Housing: galvanised steel; piston rod: high-alloy steel,
seals: perbunan, polyurethane
Free of copper, PTFE and silicone



Ordering data			
for size	Weight [g]	Part No.	Type
25	70	192 875	DG-GA-25-YSR
40	140	192 877	DG-GA-40-YSR

Toothed belt axes DGE

Accessories

Shock absorber kit YHD
for heavy-duty guide
(order code D)

Material:
Housing: Galvanised steel
Seals: TPE-U(PU) NBR
Free of copper, PTFE and silicone





Ordering data		Part No.	Type
for heavy-duty guide	Weight [g]		
HD18	203	174 544	YHD-18
HD25	293	174 545	YHD-25
HD40	515	174 546	YHD-40

Toothed belt axes DGE

Accessories

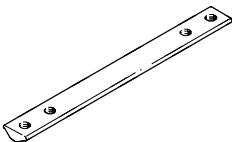

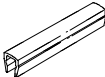
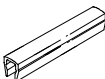
Ordering data				Technical data → Volume 1		
	for size	Remarks	Order code	Part No.	Type	PU ¹⁾
Slot nut NST						
	18, 25	For mounting slot/profile slot	Y	526 091	NST-HMV-M4	1
	40			150 914	NST-5-M5	1
	63			150 915	NST-8-M6	1
	HD18, HD25	For heavy-duty guide: mounting slot	Y	150 914	NST-5-M5	1
	HD40			150 915	NST-8-M6	1
	HD18	For heavy-duty guide:	U	150 914	NST-5-M5	1
	HD25, HD40	HD underneath		150 915	NST-8-M6	1
Slot nut NSTL						
	25	For slide	X	158 410	NSTL-25	1
	40			158 412	NSTL-40	1
	63			158 414	NSTL-63	1
	HD18	For heavy-duty guide: slide	X	161 020	NSTH-18	1
	HD25			161 021	NSTH-25	1
	HD40			161 022	NSTH-40	1
Centring pin/sleeve ZBS/ZBH						
	8 ... 18	For slide	Z	150 928	ZBS-5	10
	25 ... 63			150 927	ZBH-9	10
Central mounting SLZZ						
	HD18	For heavy-duty guide: slide	Q	150 901	SLZZ-25/16	1
	HD25					
	HD40					
Slot cover ABP						
	40	For mounting slot each 0.5 m	B	151 681	ABP-5	2
	63			151 682	ABP-8	
	HD18, HD25	For mounting slot at side and underneath, each 0.5 m		151 681	ABP-5	
	HD40			151 682	ABP-8	
Slot cover ABP-S						
	8 ... 63	For sensor slot each 0.5 m	S	151 680	ABP-5-S	2
	25	For mounting slot for DGE-ZR-RF	B			

1) Packaging unit quantity

 Core Range

Toothed belt axes DGE

Accessories



Sensor bracket HWS

for sensors
(order code T)

Material:
Galvanised steel



DGE-18/25-...ZR-KF-...

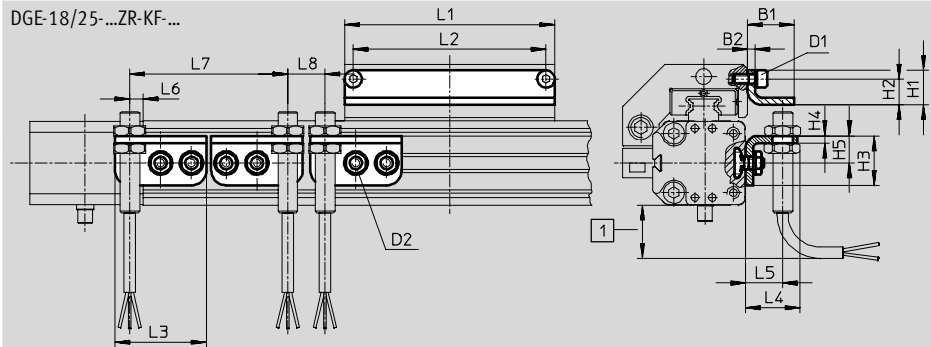

DGE-40/-63-...ZR-KF-...

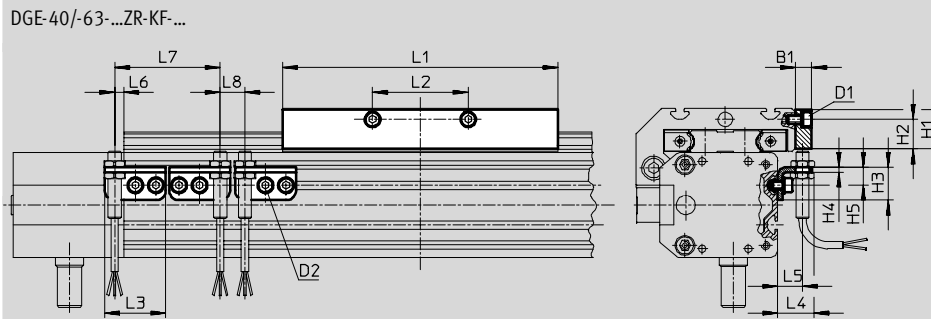

DGE-18/25-...ZR-RF-...

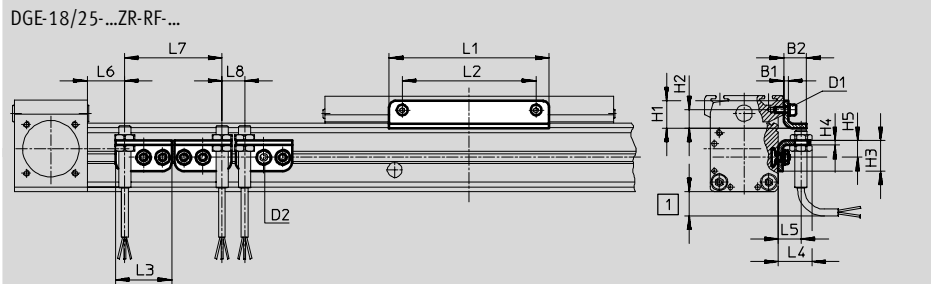

DGE-40/-63-...ZR-RF-...

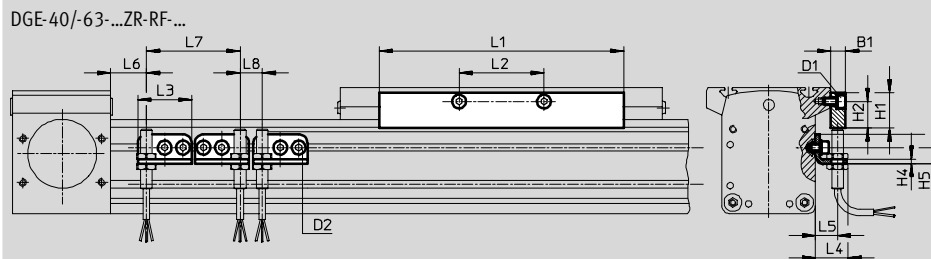

1 Protruding sensor cable, ensure sufficient installation space

Switching lug SF

(order code L)

Material:
Galvanised steel



Toothed belt axes DGE

Accessories



Dimensions and ordering data														
for size	D1	D2	B1	B2	H1	H2	H3	H4	H5	L1	L2	L3	L4	L5
18	M4	M5	19	3	14	10.5	20	3	11	85	78	37	22.5	15
25	M5	M5	15	3	18	12	20	3	11	105	88	37	22.5	15
40	M5	M5	10	-	24	18	20	3	11	167	58	37	22.5	15
63	M8	M5	10	-	35	25	20	3	11	230	72	37	22.5	15

for size	L6			L7 min.	L8 min.	Weight [g]	Part No.	Type
	DGE-ZR-KF max.	DGE-ZR-RF GK	GV					
18	5.5	-	-	64	15	30	188 968	HWS-18/25-M8
						60	188 964	SF-18
25	5.5	43.5	91	64	15	30	188 968	HWS-18/25-M8
						80	188 965	SF-25
40	5.5	68.5	138.5	64	15	40	188 969	HWS-40-M8
						310	188 966	SF-40
63	5.5	117	232	64	15	40	188 970	HWS-63-M8
						630	188 967	SF-63

Toothed belt axes DGE

Accessories



Ordering data – Proximity sensors for slot type 8, magnetic reed						Technical data → Volume 1	
	Assembly	Electrical connection		Cable length [m]	Part No.	Type	
		Cable	Plug M8				
NO contact							
	Insertable from end, flush with the cylinder profile	3-wire	–	2.5	150 855	SME-8-K-LED-24	
		–	3-pin	0.3	150 857	SME-8-S-LED-24	
NC contact							
	Insertable from above	3-wire	–	7.5	525 906	SME-8F-DO-24V-K7,5-OE	

Ordering data – Proximity sensors for slot type 8, magneto-resistive						Technical data → Volume 1		
	Assembly	Switch output	Electrical connection		Cable length [m]	Part No.	Type	
			Cable	Plug M8				
NO contact								
	Insertable from end, flush with the cylinder profile	PNP	3-pin	–	2.5	175 436	SMT-8-PS-K-LED-24-B	
			–	3-pin	0.3	175 484	SMT-8-PS-S-LED-24-B	
NC contact								
	Insertable from above	PNP	3-wire	–	7.5	525 911	SMT-8F-PO-24V-K7,5-OE	

Ordering data – Inductive proximity sensors M8						Technical data → Volume 4		
	Electrical connection		Switch output	LED	Cable length [m]	Part No.	Type	
	Cable	Plug M8						
NO contact								
	3-wire	–	PNP		2.5	150 386	SIEN-M8B-PS-K-L	
	–	3-pin	PNP			150 387	SIEN-M8B-PS-S-L	
NC contact								
	3-wire	–	PNP		2.5	150 390	SIEN-M8B-PO-K-L	
	–	3-pin	PNP			150 391	SIEN-M8B-PO-S-L	

Ordering data – Plug sockets						Technical data → Volume 1		
	Assembly	Switch output		Connection	Cable length [m]	Part No.	Type	
		PNP	NPN					
Straight socket								
	M8 locknut			3-pin	2.5	159 420	SIM-M8-3GD-2,5-PU	
					5	159 421	SIM-M8-3GD-5-PU	
Angled socket								
	M8 locknut			3-pin	2.5	159 422	SIM-M8-3WD-2,5-PU	
					5	159 423	SIM-M8-3WD-5-PU	

Core Range