



- Precision with flexibility
- Fully compatible with Festo's multi-axis modular system
- Everything from a single source

Spindle axes DGE

Key features

At a glance

- Precision, rigid guide
- Highly adaptable, thanks to wide choice of mounting and attachment options
- Wide range of options for attaching drive units
- Comprehensive range of mounting accessories for multi-axis combinations
- Optimally adapted motor controller combinations

Basic version DGE-SP

- Stroke lengths from 100 ... 2000 mm
- Without guide
- Low characteristic load values



With recirculating ball bearing guide DGE-SP-KF-GK/-GV

- Stroke lengths from 100 ... 2000 mm
- Standard slide or extended slide
- Medium to high characteristic load values



With protected version DGE-SP-KF-GA

- Stroke lengths from 140 ... 1500 mm
- Guide and slide are fitted with a cover to protect against the ingress of particles from above and from the side



With heavy-duty guide DGE-SP-HD

- Stroke lengths from 100 ... 1500 mm
- High guide precision
- Sturdy construction
- High characteristic load values



Spindle axes DGE

Key features

System selection for electromechanical drives

Axis controller
SPC-200
→ 5 / 1.3-2



Servo motor controller
SEC-AC
→ 5 / 2.2-26



Stepper motor controller
SEC-ST
→ 5 / 2.2-13



Stepper motor
MTR-ST
→ 5 / 2.2-2



Servo motor
MTR-AC
→ 5 / 2.2-16



Coupling
KSE-...
→ 5 / 2.3-3



Motor flange
MTR-FL-...
→ 5 / 2.3-8



Spindle axis
with recirculating ball bearing guide
DGE-...-SP-KF...



Toothed belt axis
with recirculating ball bearing guide
DGE-...-ZR-KF...



Toothed belt axis
with roller guide
DGE-...-ZR-RF...



Cantilever axis
DGEA-...-ZR-...

Spindle axes DGE

System example

System product for handling and assembly technology

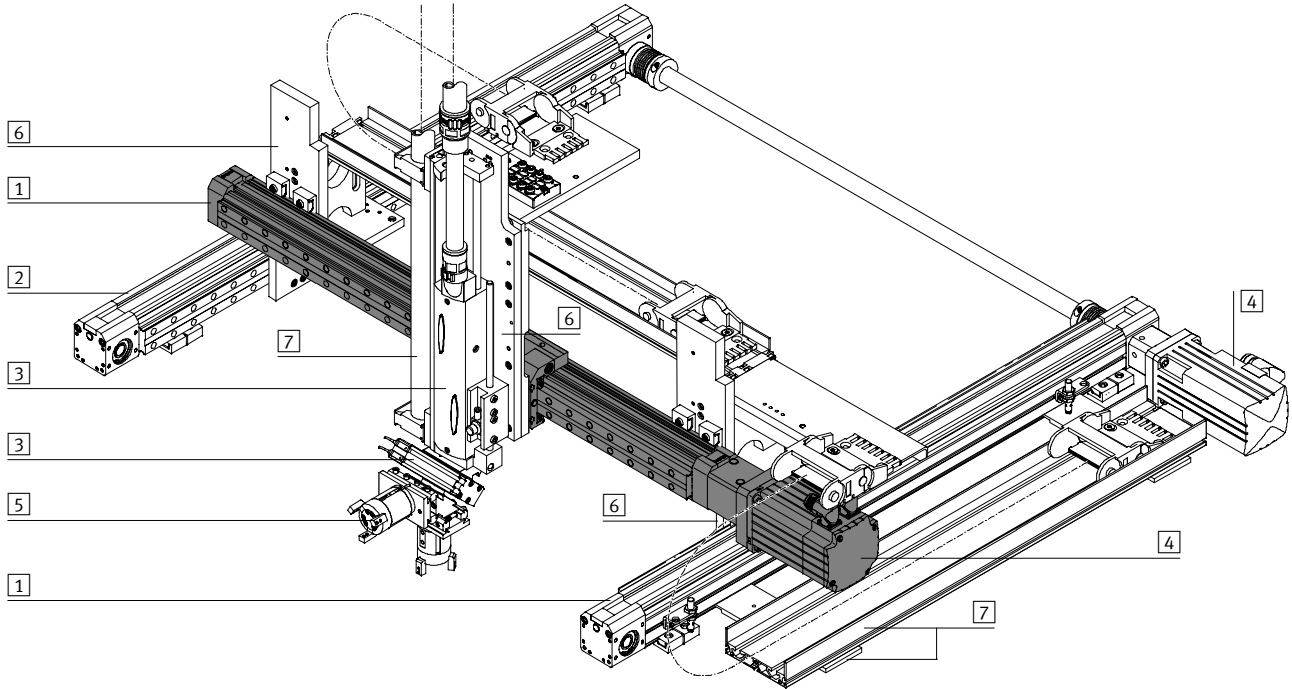

System components and accessories

Type	Brief description	→ Page
1 Axes	Wide range of combination options within handling and assembly technology	Volume 5
2 Passive guide axes	Diverse possible combinations in handling and assembly technology	Volume 5
3 Drives	Wide range of combination options within handling and assembly technology	Volume 1
4 Motors	Servo and stepper motors, with or without gearing	Volume 5
5 Grippers	Wide range of combination options within handling and assembly technology	Volume 1
6 Adapters	For combining drives with drives and drives with grippers	Volume 5
7 Installation components	For achieving a clear-cut, safe layout for electrical cables and tubing	Volume 5

Spindle axes DGE

Selection aid

Guide characteristics

The data in the table are maximum values. The precise values for each variant can be found in the corresponding data sheet included in the catalogue.

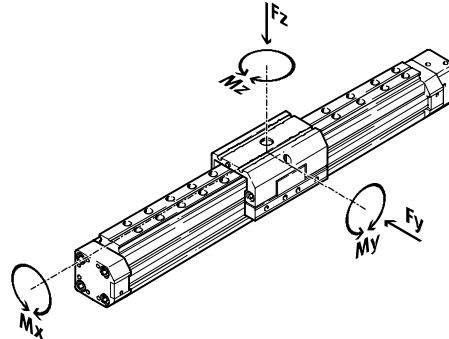

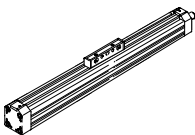
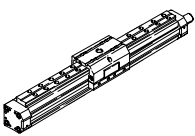
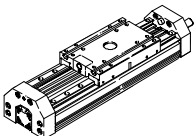
Version	Size	Working stroke [mm]	Speed [m/s]	Repetition accuracy [mm]	Feed force [N]	Forces and torques					→ Page
						Fy [N]	Fz [N]	Mx [Nm]	My [Nm]	Mz [Nm]	
Basic version without guide SP											
	18	100 ... 500	0.2	±0.02	140	–	1.8	0.5	0.8	0.8	5 / 2.1-118
	25	100 ... 1000	0.5	±0.02	250	–	2	1	1.5	1.5	
	40	200 ... 1500	1	±0.02	600	–	15	4	4	4	
	63	300 ... 2000	1.2	±0.02	1600	–	106	8	18	18	
With recirculating ball bearing guide SP-KF											
	18	100 ... 500	0.2	±0.02	140	930	930	7	45	45	5 / 2.1-132
	25	100 ... 1000	0.5	±0.02	250	3080	3080	45	170	170	
	40	140 ... 1500	1	±0.02	600	7300	7300	170	660	660	
	63	150 ... 2000	1.2	±0.02	1600	14050	14050	580	1820	1820	
With heavy-duty guide SP-HD											
	18	100 ... 400	0.2	±0.02	140	1820	1820	70	115	112	5 / 2.1-154
	25	100 ... 900	0.5	±0.02	250	5400	5600	260	415	400	
	40	200 ... 1500	1	±0.02	600	5400	5600	375	560	540	

Spindle axes DGE-SP

Peripherals overview



2.1

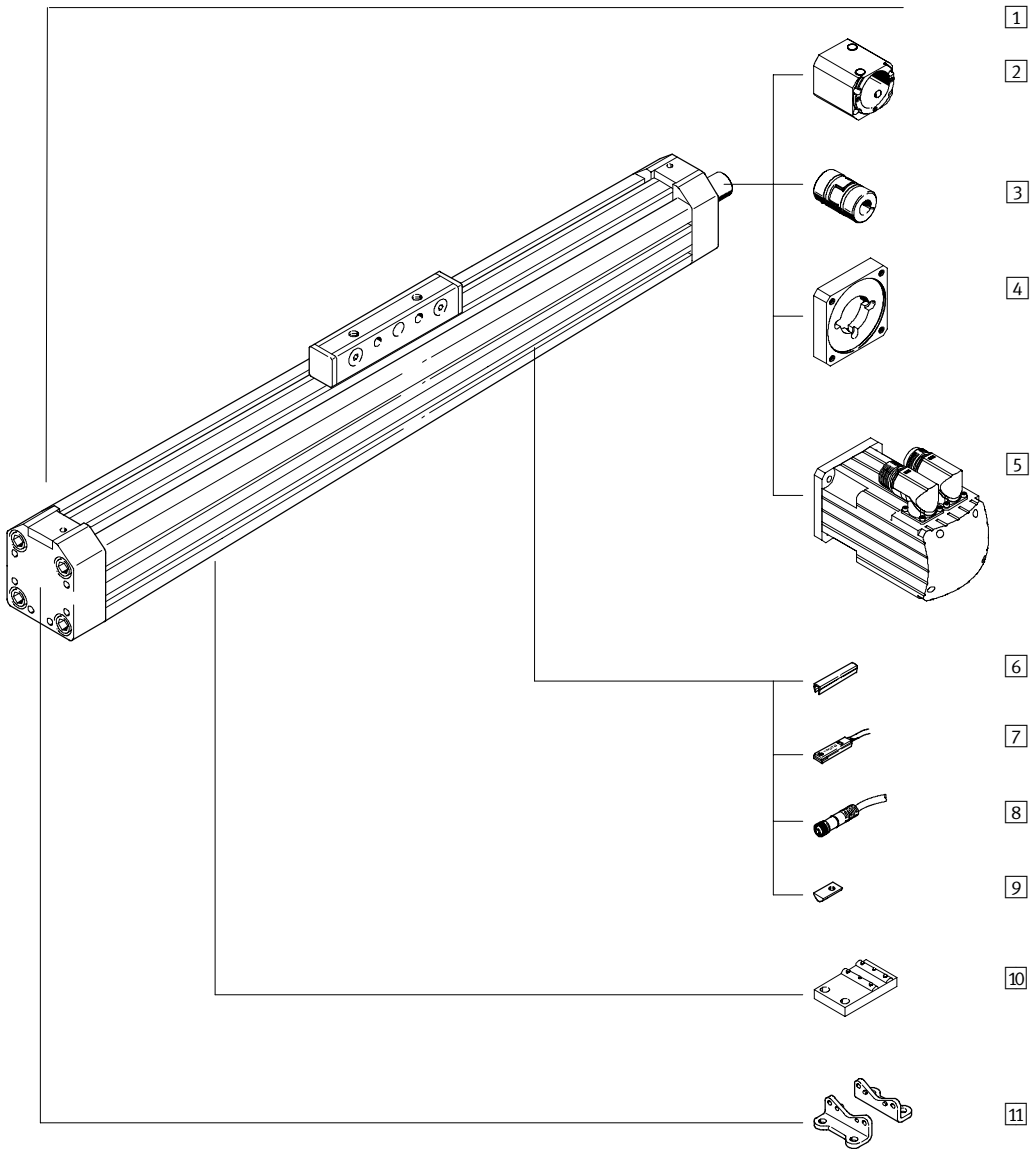

Spindle axes DGE-SP

Peripherals overview

Variants and accessories		
Type	Brief description	→ Page
1 Spindle axis DGE-SP	Electromechanical axis without guide	5 / 2.1-120
2 Coupling housing KG	Adapter for mounting the motor on the axis	5 / 2.1-168
3 Coupling KSE	Connecting element between axis and motor	5 / 2.1-168
4 Motor flange MTR-FL	Connecting element between coupling housing and motor	5 / 2.1-168
5 Motor MTR	Motors specially matched to the axis, with or without gearing, with or without brake	5 / 2.1-168
6 Slot cover B/S	For protecting against the ingress of dirt	5 / 2.1-175
7 Proximity sensor G/H/I/J/N	For use as a signal generator and safety monitoring	5 / 2.1-177
8 Plug socket with cable V	For proximity sensors	5 / 2.1-177
9 Slot nut for mounting slot Y	For mounting attachments	5 / 2.1-175
10 Central support M	For mounting the axis	5 / 2.1-170
11 Foot mounting F	For mounting the axis	5 / 2.1-170

Spindle axes DGE-SP

Type code



		DGE	-	25	-	500	-	SP	-	KG	-	SED	-	
Type														
DGE	Spindle axis													
Size														
Stroke [mm]														
Drive function														
SP	Spindle													
Coupling housing														
KG	Coupling housing													
LG	Coupling housing attached, large design													
Type of motor														
STD	Stepper motor													
STED	Stepper motor with integrated power electronics													
STG	Stepper motor with gearing													
SED	Servo motor													
SEDP	Servo motor for high performance													
Motor brake														
BR	Brake													

Spindle axes DGE-SP

Type code



Spindle axes DGE-SP

Technical data



- - Size
18 ... 63
- - Stroke length
100 ... 2000 mm

- - www.festo.com/en/Spare_parts_service

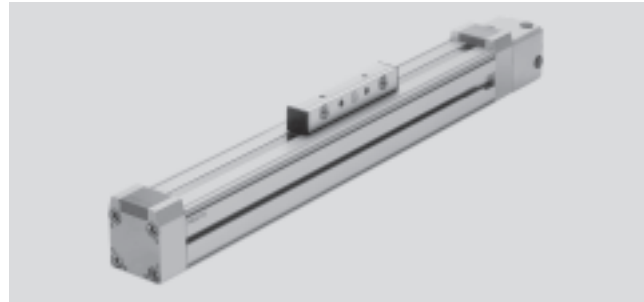

General technical data					
Size		18	25	40	63
Constructional design		Electromechanical axis with spindle and driver			
Guide		-			
Mounting position		Any			
Max. working stroke ¹⁾	[mm]	100 ... 500	100 ... 1000 ²⁾	200 ... 1500 ²⁾	300 ... 2000 ²⁾
Max. working load	[kg]	6	25	50	150
Max. feed force F_x	[N]	140	250	600	1600
Max. driving torque	[Nm]	0.1	0.45	2.1	8.5
Max. no-load driving torque ³⁾	[Nm]	0.05	0.15	0.5	1.4
Max. speed	[m/s]	0.2	0.5	1	1.2
Repetition accuracy	[mm]	±0.02			

- 1) Total stroke = working stroke + 2x stroke reserve
- 2) The maximum speed is dependent on the stroke length → 5 / 2.1-126
- 3) Measured at a speed of 0.2 m/s

Operating and environmental conditions					
Size		18	25	40	63
Ambient temperature	[°C]	0 ... +40			
Protection class		IP40			

Weights [kg]					
Size		18	25	40	63
Basic weight with 0 mm stroke ¹⁾		0.55	1.4	4.3	12.5
Additional weight per 100 mm stroke		0.21	0.41	0.71	2.53
Moving load		0,13	0,25	0,67	2,17

- 1) Including coupling housing

Mass moment of inertia					
Size		18	25	40	63
J_0	[kg cm ²]	0.007	0.029	0.364	3.15
J_H per metre stroke	[kg cm ² /m]	0.031	0.121	1	6.67
J_L per kg working load	[kg cm ² /kg]	0.005	0.025	0.101	0.228

The mass moment of inertia J_A of the entire axis is calculated as follows:

$$J_A = J_0 + J_H \times \text{working stroke [m]} + J_L \times m_{\text{working load [kg]}}$$

Spindle axes DGE-SP

Technical data

Spindle					
Size		18	25	40	63
Diameter	[mm]	8	12	20	32
Pitch	[mm/rev.]	4	10	20	30

Materials

Sectional view

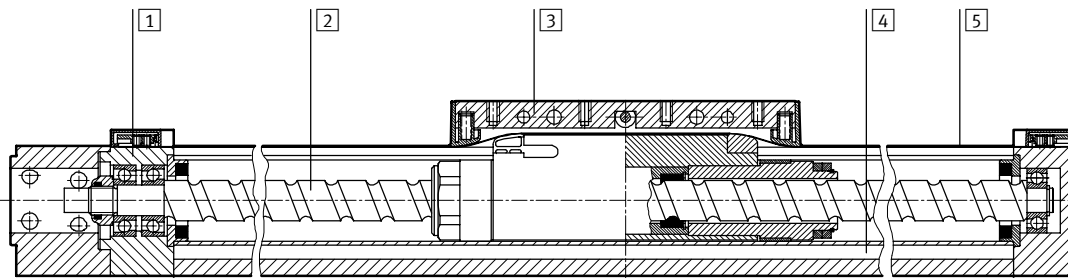

Axis		
1	End cap	Anodised aluminium
2	Spindle	Rolled steel
3	Driver	Anodised aluminium
4	Profile	Anodised aluminium
5	Cover strip	Corrosion resistant steel

Stroke reserve

L12 The stroke reserve is a safety distance available on both sides of the axis in addition to the stroke.

L11 Internal mechanical stop

L1+ Overall length of axis

1 Working stroke

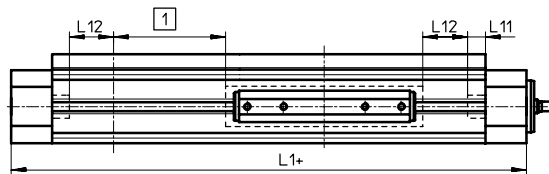

Example:

Type DGE-25-500-SP

Working stroke = 500 mm

Stroke reserve = (2x 10 mm)

= 20 mm

Total stroke = 500 mm + 20 mm

= 520 mm

Size		18	25	40	63
L12 per end position	[mm]	6.5	10	20	30

Spindle axes DGE-SP

Technical data



Characteristic load values

The indicated forces and torques refer to the centre line of the internal diameter of the profile.

They must not be exceeded in the dynamic range. Special attention must be paid to the cushioning phase.

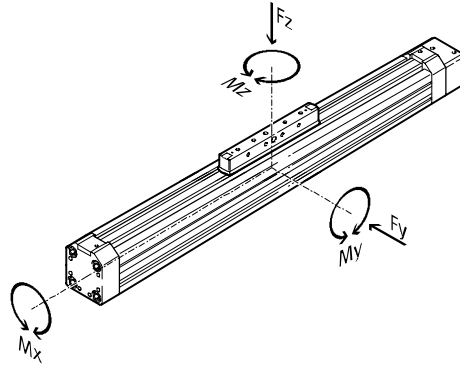

If the axis is subjected to more than two of the indicated forces and torques simultaneously, the following equations must be satisfied in addition to the indicated maximum loads:

$$\frac{F_z}{F_{z_{max}}} + \frac{M_y}{M_{y_{max}}} + \frac{M_z}{M_{z_{max}}} \leq 1$$

$$\frac{M_x}{M_{x_{max}}} \leq 1$$

Permissible forces and torques

Size	18	25	40	63
F _y _{max.} [N]	–	–	–	–
F _z _{max.} [N]	1.8	2	15	106
M _x _{max.} [Nm]	0.5	1	4	8
M _y _{max.} [Nm]	0.8	1.5	4	18
M _z _{max.} [Nm]	0.8	1.5	4	18

2nd moment of area

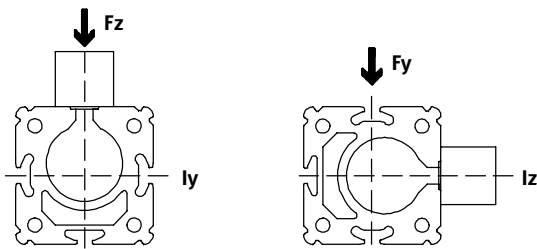

Size	18	25	40	63
ly [mm ⁴]	69.8x10 ³	224x10 ³	673x10 ³	5688x10 ³
lz [mm ⁴]	72.3x10 ³	240x10 ³	748x10 ³	6031x10 ³



PtTool
design tool
www.festo.com/en/engineering

Spindle axes DGE-SP

Technical data

Maximum permissible support span l as a function of the force F

The axis may need to be supported with central supports in order to restrict deflection with long stroke lengths. The following diagrams serve to determine the maximum permissible support span l as a function of the force acting upon the axis F .

1 Force on the surface of the driver

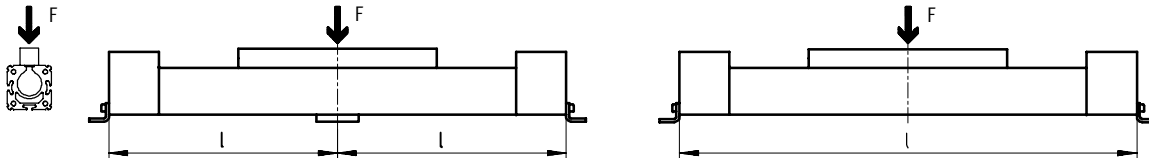

2 Force on the front of the driver

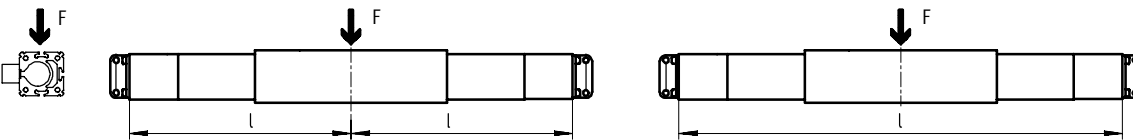

Maximum permissible support span l (without central support) as a function of the force F

DGE-18

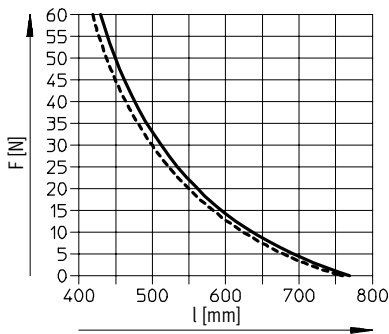

DGE-25

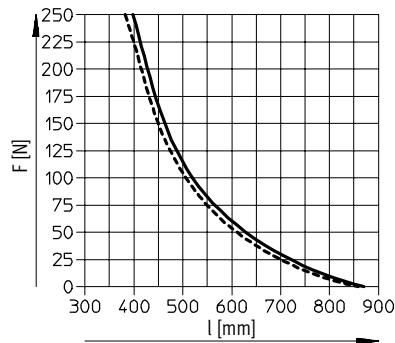

DGE-40

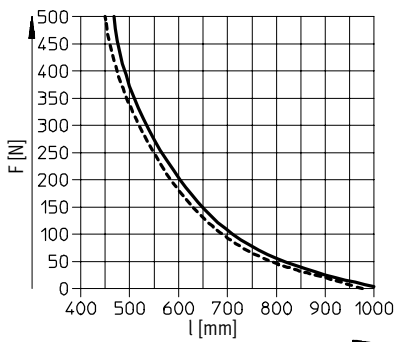

DGE-63

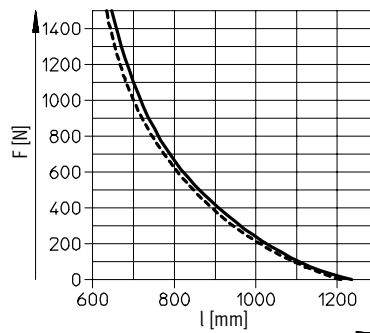

- 1
- - - 2

Spindle axes DGE-SP

Technical data



Maximum permissible speed v or drive rpm n as a function of the stroke l

DGE-18

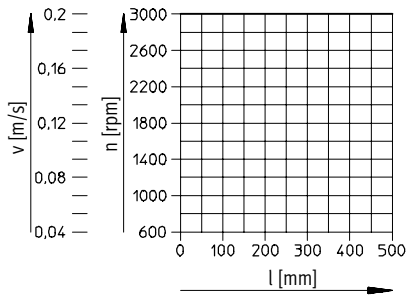

DGE-25

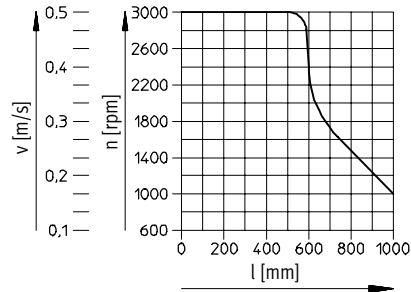

DGE-40

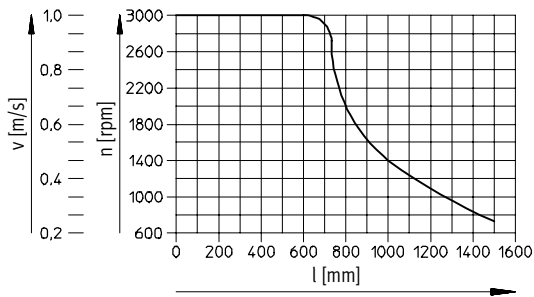

DGE-63

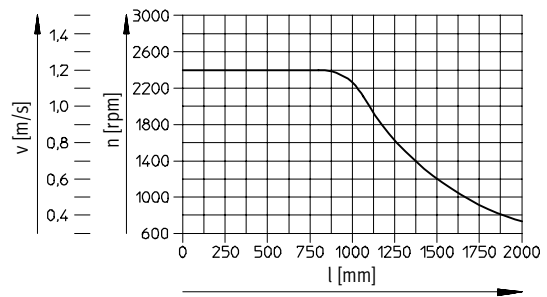

Spindle axes DGE-SP

Technical data



Dimensions

Download CAD data → www.festo.com/en/engineering

Size 18

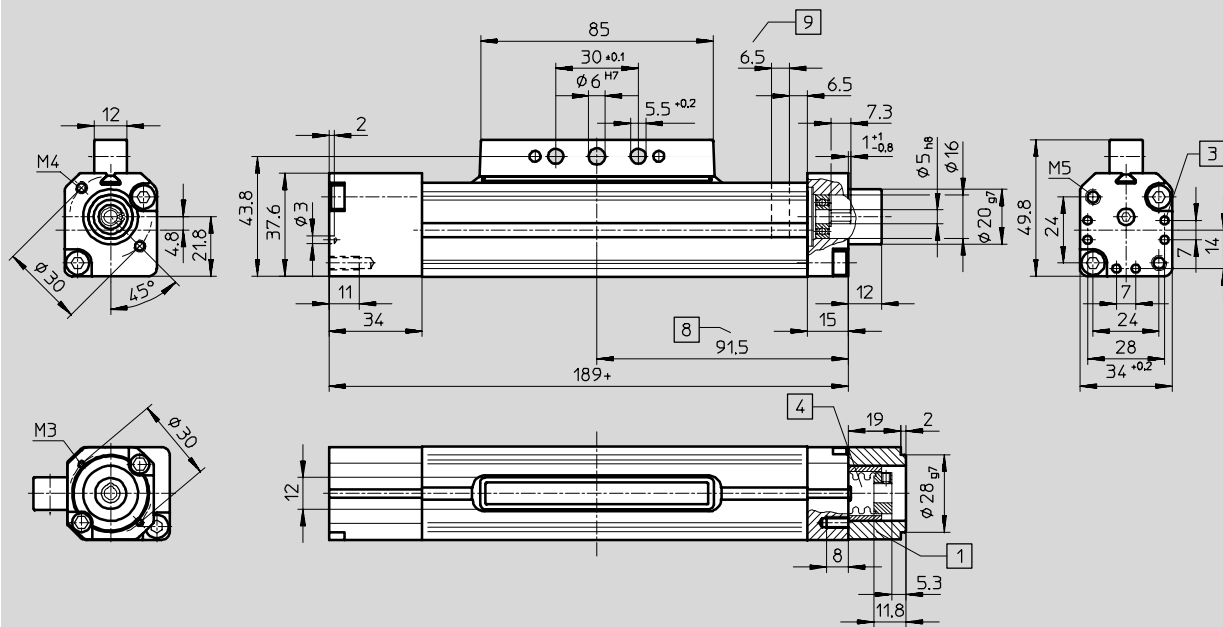

- 1 Coupling housing
 - 2 Sensor slot for proximity sensor
 - 3 Centring hole for foot mounting HP
 - 4 Coupling
 - 8 Driver in end position of the working stroke
 - 9 Recommended stroke reserve
- + = plus stroke length

Profile

Size 18

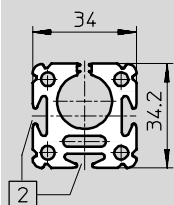

Spindle axes DGE-SP

Technical data



Dimensions

Download CAD data → www.festo.com/en/engineering

Size 25 ... 63

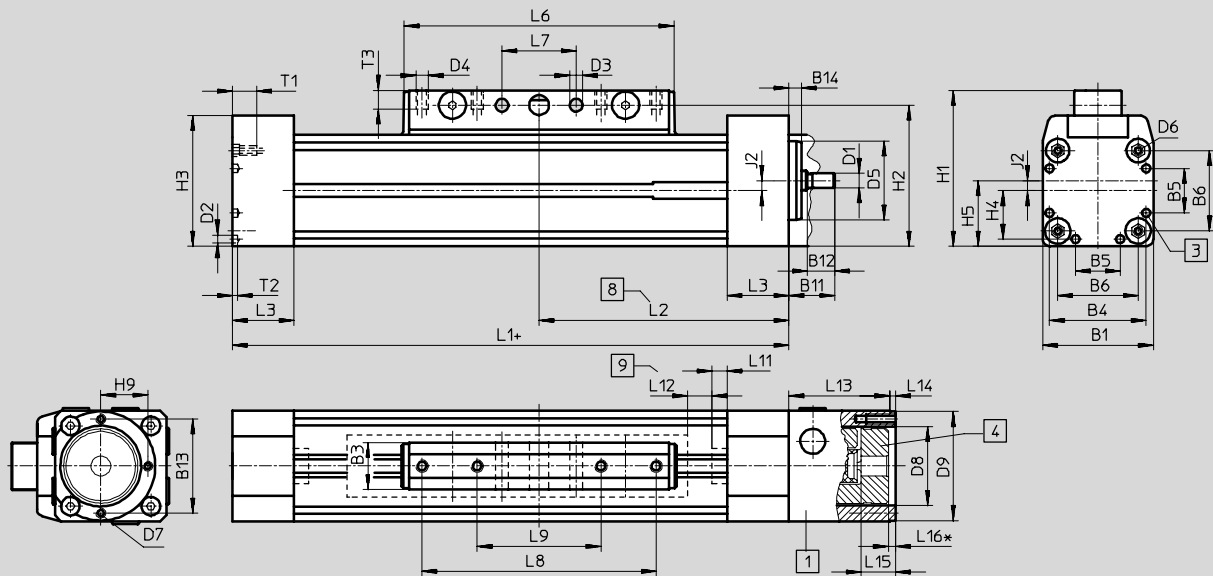

- 1 Coupling housing
- 3 Centring hole for foot mounting HP
- 4 Coupling
- 8 Applies to end positions where stroke reserve is maintained up to the mechanical stop
- 9 Stroke reserve (available safety distance from mechanical end position at both ends)
- + = plus stroke length

Profile

Size 25

Size 40

Size 63

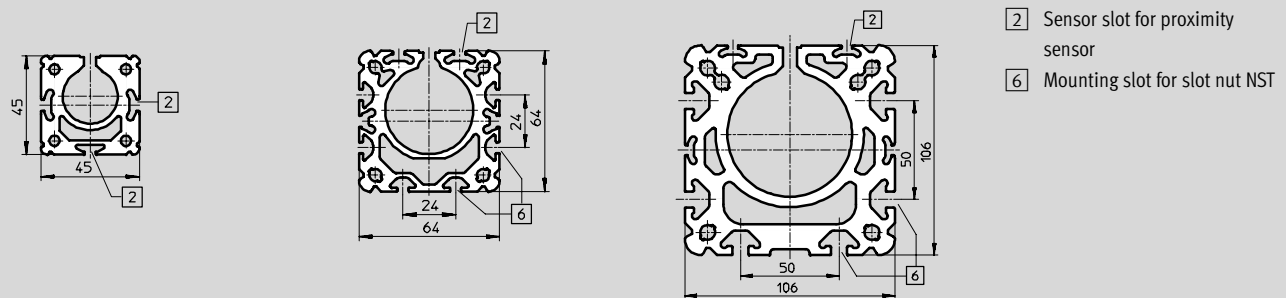

Size	B1	B3 +0.2	B4	B5	B6	B11	B12	B13	B14	D1 ∅ h6	D2 ∅	D3 ∅ +0.2	D4	D5 ∅ g7	D6	D7	D8 ∅	D9 ∅ g7	H1	H2	H3
25	45	19	39.1	18	32.5	18.5	11	38	4	6	3.3	5.2	M5	32	M4	M4	32	44	63	57	52.8
40	64	21	53	28	49	22.5	12	38	5	12	4.4	6.5	M5	48	M5	M4	32	44	86	78	71.8
63	106	24	89	44	83	47.5	25	56	7	20	6.4	8.5	M8	72	M8	M6	48	64	131	122	115

Size	H4	H5	H9	J2	L1	L2	L3	L6	L7	L8	L9	L11	L12	L13	L14	L15	L16 ¹⁾	T1	T2	T3
25	19.6	26.5	19	4	213	101.5	25	109	30	–	50	6	10	43	2.5	14	3	13	2	7.5
40	26.5	37	19	5	315	153	31	171	70	130	40	7	20	46	3	14.5	3.5	13	3	10.5
63	44.5	61	28	8	410	200	63	234	110	190	70	9	30	83	4	23	–2	21	4	12.5

1) Negative dimension: Protrudes beyond coupling housing

Spindle axes DGE-SP

Ordering data – Modular products



Order code

Mandatory data

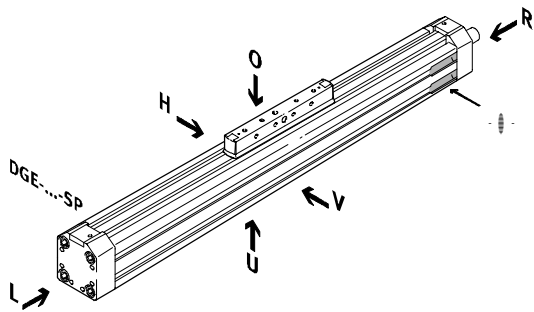

- - Note

The insertion point for the proximity sensor is located on the right-hand side of the spindle axis DGE-...-SP

- O top
- U underneath
- V front
- H rear
- R right
- L left

Order code

Options

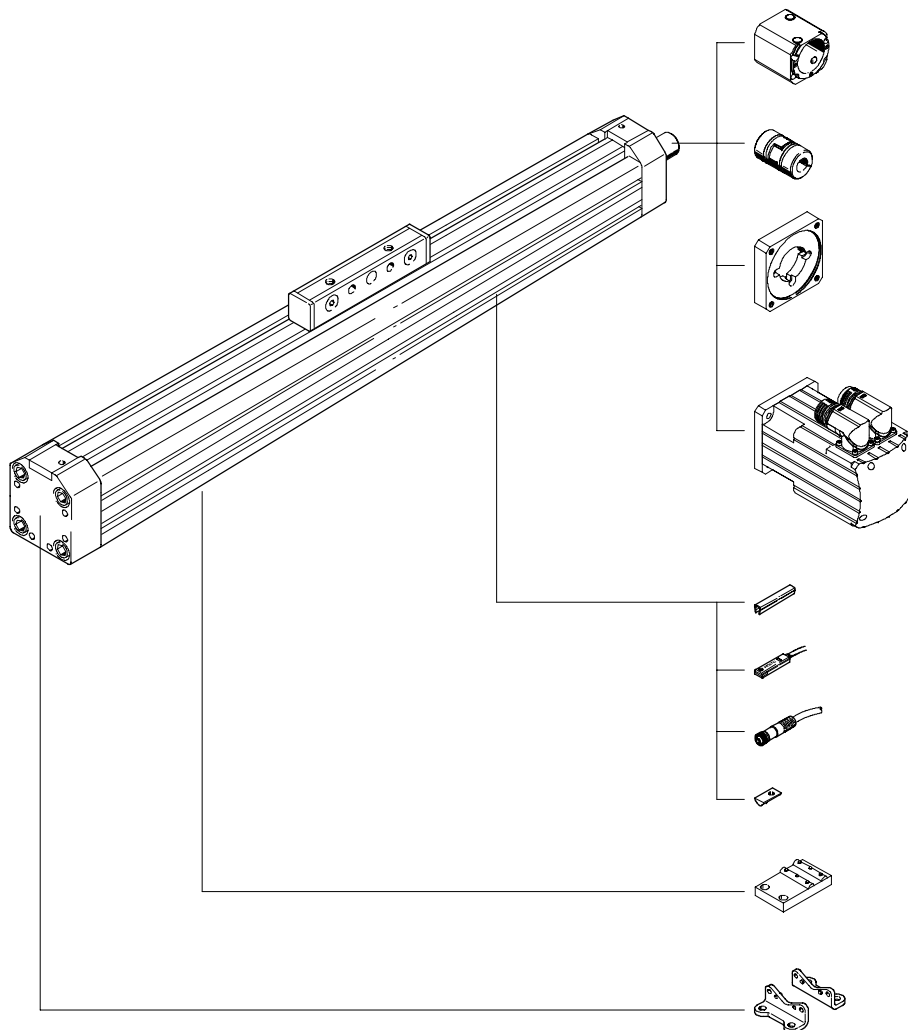

KG

Coupling
(included in the scope of delivery when ordering a motor)

Flange
(included in the scope of delivery when ordering a motor)

Motor options
SED/SEDP
STD/STED/STG

B/S

G/H/I/J/N

V

Y

M

F

Spindle axes DGE-SP

Ordering data – Modular products



M Mandatory data					O Options →		
Module No.	Design	Size	Stroke	Drive function	Coupling housing	Type of motor	Brake
193 745	DGE	18	1 ... 2 000	SP	KG LG	STD STED STG SED SEDP	BR
193 746		25					
193 747		40					
193 748		63					
Ordering example							
193 747	DGE	- 40	- 800	- SP	- LG	- SEDP	- BR

Ordering table							
Size	18	25	40	63	Condi- tions	Code	Enter code
M Module No.	193 745	193 746	193 747	193 748			
Design	Electromechanical linear axis						DGE
Size	18	25	40	63		-...	
Stroke [mm]	100, 200, 300, 400, 500	100, 200, 300, 400, 500, 600, 700, 800, 900, 1000	200, 300, 400, 500, 600, 800, 1000, 1200, 1400, 1500	300, 400, 500, 600, 800, 1000, 1200, 1400, 1500, 180 0, 2000		-...	
	-	1 ... 1000	1 ... 1500	1 ... 2000			
Drive function	Electromechanical drive with ball screw						-SP
O Coupling housing	Coupling housing						-KG
	-	-	Attached, large design	-			-LG
Type of motor	Stepper motor	Stepper motor			-	1 2	-STD
		with integrated power electronics			-	1	-STED
		-			with gearing	1	-STG
	Servo motor	Servo motor			-	1 3	-SED
-			for high performance	-	1 2	-SEDP	
Brake	Motor brake					4	-BR

1 STD, STED, STG, SED, SEDP

For sizes 18, 25, 63 only with coupling housing KG.

2 STD, SEDP

For size 40 only with coupling housing LG.

3 SED

For size 40 only with coupling housing KG.

4 BR

Only permissible with motor type.

Allocation of order codes to motor types

→ from 5 / 2.1-168

The motor controller and cable set must be ordered separately.

Stepper motor → 5 / 2.2-2

Servo motor → 5 / 2.2-16

Transfer order code

	DGE	-		-		-	SP	-		-		-	
--	-----	---	--	---	--	---	----	---	--	---	--	---	--

Spindle axes DGE-SP

Ordering data – Modular products



Options

Accessories	Slot cover	Slot nut	Central support	Foot mounting	Proximity sensor	Plug socket
ZUB	...S ...B	...Y	...M	...F	...G ...H ...I ...J ...N	...V
ZUB	- 2S2B	10Y		F	2G	

Ordering table		18	25	40	63	Condi- tions	Code	Enter code
↓	Accessories	Supplied separately					ZUB-	ZUB-
0	Slot cover	Sensor slot	1 ... 10				...S	
		Mounting slot	–	–	1 ... 10		...B	
	Slot nut	for mounting slot	1 ... 10				...Y	
	Central support		1 ... 10				...M	
	Foot mounting (kit)		1 ... 10				...F	
	Proximity sensor	with cable, 2.5 m	1 ... 10				...G	
		with plug	1 ... 10				...H	
		contactless with cable, 2.5 m	1 ... 10				...I	
		contactless, plug	1 ... 10				...J	
		NC contact with cable, 2.5 m	1 ... 10				...N	
	Plug socket	with cable, 2.5 m	1 ... 10				...V	

Electrical positioning systems
Electromechanical drives

2.1

Transfer order code

ZUB	-						
-----	---	--	--	--	--	--	--

Spindle axes DGE-SP-KF, with recirculating ball bearing guide

Peripherals overview

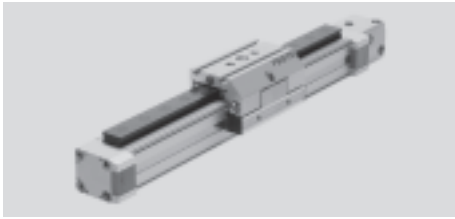

Electrical positioning systems
Electromechanical drives

2.1

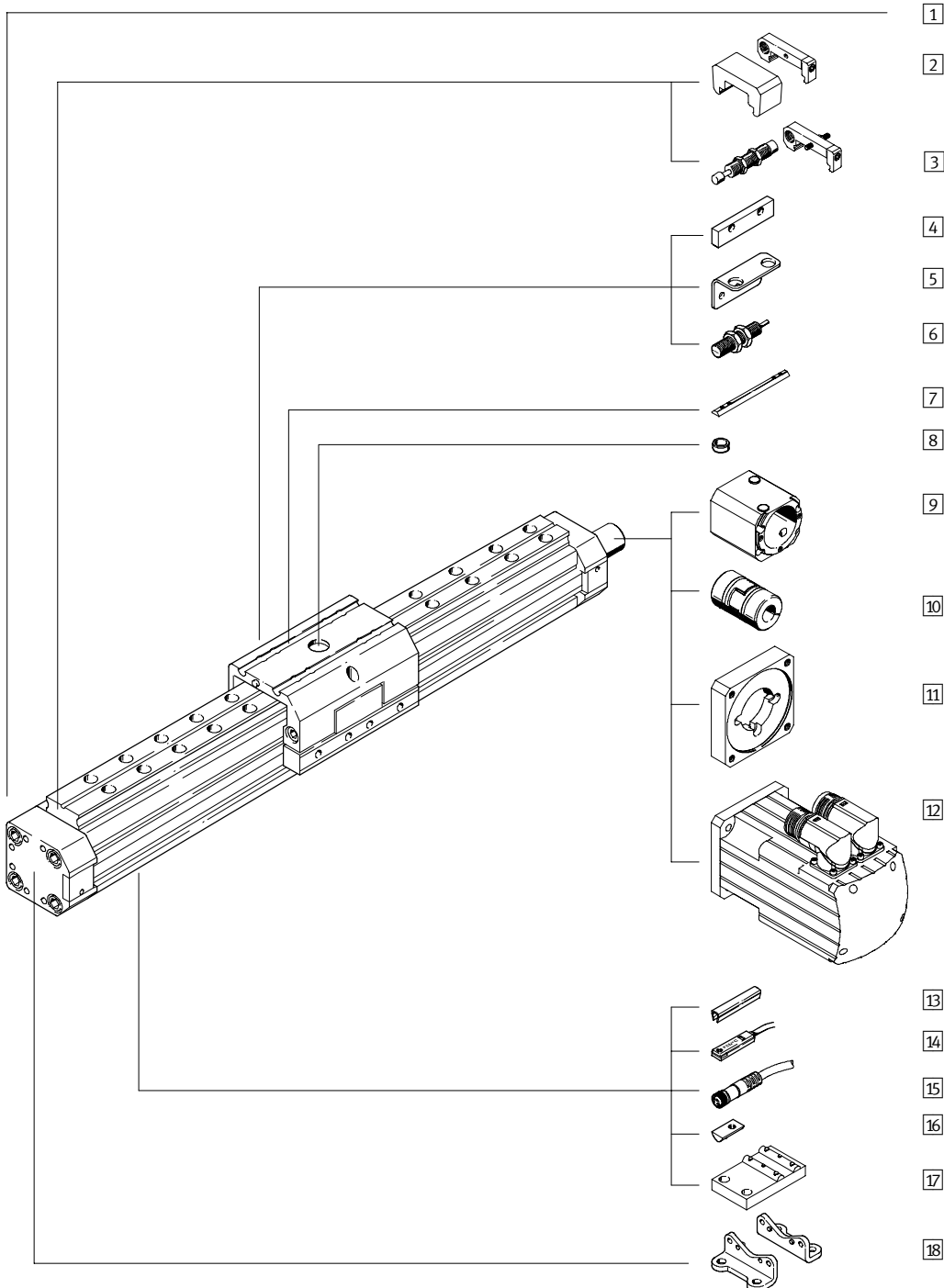

Spindle axes DGE-SP-KF, with recirculating ball bearing guide

Peripherals overview

Variants and accessories					
Type	Brief description	GK/GV	GA	→ Page	
1	Spindle axis DGE-SP-KF	Electromechanical axis with spindle and recirculating ball bearing guide	■	■	5 / 2.1-134
2	Emergency buffer with retainer ¹⁾ A	For avoiding damage at the end stop in the event of malfunction	■	■	5 / 2.1-173
3	Shock absorber kit C	For avoiding damage at the end stop in the event of malfunction	■	-	5 / 2.1-172
3	Shock absorber kit E	For avoiding damage at the end stop in the event of malfunction	-	■	5 / 2.1-173
4	Switching lug L	For sensing the slide position	■	-	5 / 2.1-176
5	Sensor bracket T	Adapter for mounting the inductive proximity sensors on the axis	■	-	5 / 2.1-176
6	Inductive proximity sensor O/P/R/W	For use as a signal generator and safety monitoring	■	-	5 / 2.1-177
7	Slot nut for slide X	For mounting loads and attachments on the slide	■	■	5 / 2.1-175
8	Centring pins/sleeves Z	For centring loads and attachments on the slide	■	■	5 / 2.1-175
9	Coupling housing KG	Adapter for mounting the motor on the axis	■	■	5 / 2.1-168
10	Coupling KSE	Connecting element between axis and motor	■	■	5 / 2.1-168
11	Motor flange MTR-FL	Connecting element between coupling housing and motor	■	■	5 / 2.1-168
12	Motor MTR	Motors specially matched to the axis, with or without gearing, with or without brake	■	■	5 / 2.1-168
13	Slot cover B/S	For protecting against the ingress of dirt	■	■	5 / 2.1-175
14	Proximity sensor G/H/I/J/N	For use as a signal or safety check	■	■	5 / 2.1-177
15	Plug socket with cable V	For proximity sensors	■	■	5 / 2.1-177
16	Slot nut for mounting slot Y	For mounting attachments	■	■	5 / 2.1-175
17	Central support M	For mounting the axis	■	■	5 / 2.1-170
18	Foot mounting F	For mounting the axis	■	■	5 / 2.1-170

1) Fitted as standard for GV and GA.

Spindle axes DGE-SP-KF, with recirculating ball bearing guide

Type code



		DGE	-	25	-	500	-	SP	-	KG	-	KF	-	GK	-	SV	-		-	SED	-	
Type																						
DGE	Spindle axis																					
Size																						
Stroke [mm]																						
Drive function																						
SP	Spindle																					
Coupling housing																						
KG	Coupling housing																					
LG	Coupling housing attached, large design																					
Guide																						
KF	Recirculating ball bearing guide																					
Slide																						
GK	Standard slide																					
GV	Extended slide																					
GA	Protected version																					
Slide attachment position																						
SV	At front																					
SH	At rear																					
Additional slide																						
KL	Left																					
KR	Right																					
Type of motor																						
STD	Stepper motor																					
STED	Stepper motor with integrated power electronics																					
STG	Stepper motor with gearing																					
SED	Servo motor																					
SEDP	Servo motor for high performance																					
Motor brake																						
BR	Brake																					

Spindle axes DGE-SP-KF, with recirculating ball bearing guide

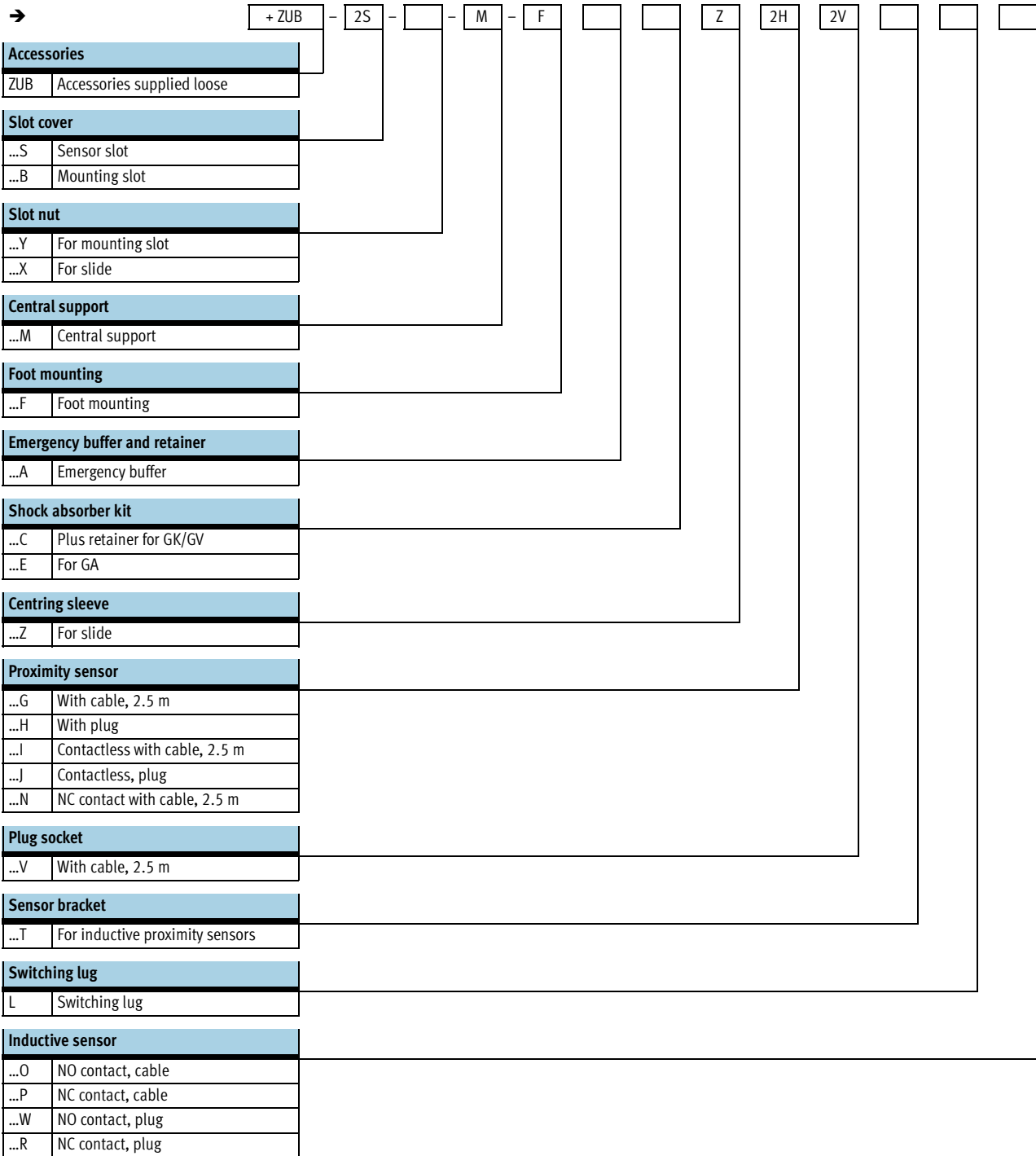

Type code



Spindle axes DGE-SP-KF, with recirculating ball bearing guide

Technical data



-  - Size
18 ... 63
-  - Stroke length
100 ... 2000 mm

-  - www.festo.com/en/Spare_parts_service

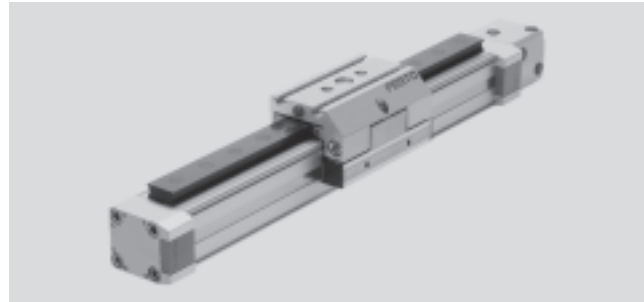

General technical data						
Size			18	25	40	63
Constructional design	Electromechanical axis with spindle and recirculating ball bearing guide					
Guide	Recirculating ball bearing guide					
Mounting position	Any					
Max. working stroke ¹⁾	GK	[mm]	100 ... 500	100 ... 1000 ²⁾	200 ... 1500 ²⁾	300 ... 2000 ²⁾
	GV	[mm]	110 ... 410	170 ... 870 ²⁾	170 ... 1270 ²⁾	150 ... 1650 ²⁾
	GA	[mm]	–	170 ... 970 ²⁾	140 ... 1440 ²⁾	–
Max. working load		[kg]	6	25	50	150
Max. feed force F_x		[N]	140	250	600	1600
Max. driving torque		[Nm]	0.1	0.45	2.1	8.5
Max. no-load driving torque ³⁾		[Nm]	0.05	0.15	0.5	1.4
Max. speed		[m/s]	0.2	0.5	1	1.2
Repetition accuracy		[mm]	±0.02			

- 1) Total stroke = working stroke + 2x stroke reserve → 5 / 2.1-140
- 2) The maximum speed is dependent on the stroke length → 5 / 2.1-142
- 3) Measured at a speed of 0.2m/s

Operating and environmental conditions						
Size			18	25	40	63
Ambient temperature		[°C]	0 ... +40			
Protection class	IP40					

Weights [kg]						
Size			18	25	40	63
Basic weight with 0 mm stroke ¹⁾	GK		1	2.1	6.4	18.1
	GV		1.52	3.26	10.04	32.2
	GA		–	3.1	8.97	–
Additional weight per 100 mm stroke	GK		0.3	0.56	1.14	3.31
	GV		0.3	0.56	1.14	3.31
	GA		–	0.65	1.26	–
Moving load	GK		0,45	0,68	1,82	5,38
	GV		0,61	0,94	2,54	7,84
	GA		–	1,24	3,19	–
Additional slide	KL/KR		0.25	0.38	1.06	3.1

- 1) Including coupling housing and slide

Spindle axes DGE-SP-KF, with recirculating ball bearing guide

Technical data

Mass moment of inertia						
Size			18	25	40	63
J ₀	GK	[kg cm ²]	0.008	0.04	0.48	3.88
	GV	[kg cm ²]	0.0117	0.0617	0.782	6.77
	GA	[kg cm ²]	–	0.0573	0.678	–
J _H per metre stroke		[kg cm ² /m]	0.031	0.121	1	6.67
J _L per kg working load		[kg cm ² /kg]	0.005	0.025	0.101	0.228
J _W for additional slide		[kg cm ²]	0.001	0.0096	0.107	0.707

The mass moment of inertia J_A of the entire axis is calculated as follows:

$$J_A = J_0 + J_H \times \text{working stroke [m]} + J_L \times m_{\text{working load [kg]}}$$

Spindle						
Size			18	25	40	63
Diameter		[mm]	8	12	20	32
Pitch		[mm/rev.]	4	10	20	30

Materials

Sectional view

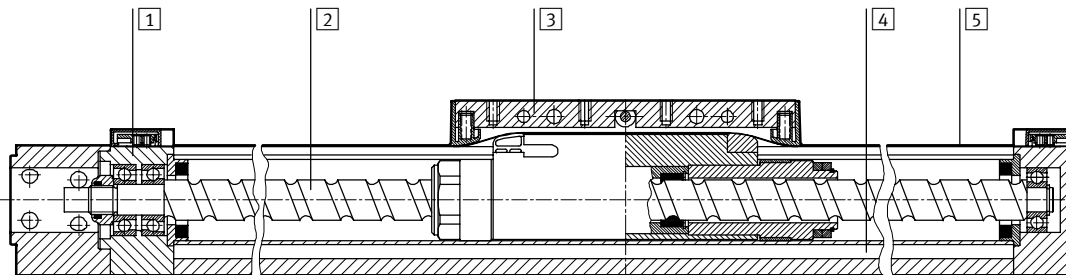

Axis		
1	End cap	Anodised aluminium
2	Spindle	Rolled steel
3	Slide	Anodised aluminium
4	Profile	Anodised aluminium
5	Cover strip	Corrosion resistant steel

Spindle axes DGE-SP-KF, with recirculating ball bearing guide

Technical data



Characteristic load values for axis with standard slide GK or protected version GA

The indicated forces and torques refer to the centre of the guide rail. They must not be exceeded in the dynamic range. Special attention must be paid to the cushioning phase.

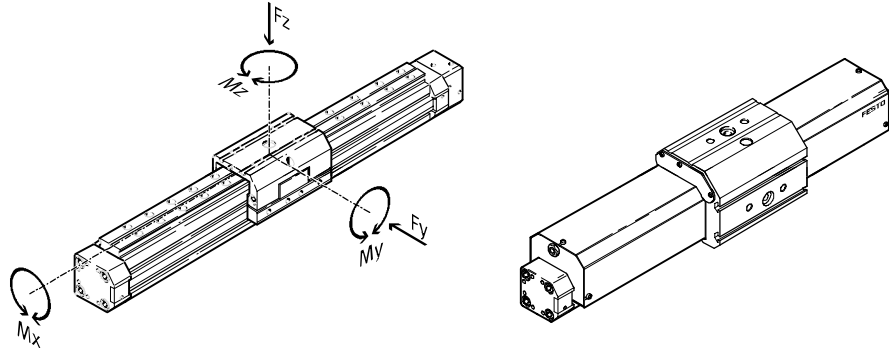

If the drive is subjected to more than two of the indicated forces and torques simultaneously, the following equations must be satisfied in addition to the indicated maximum loads:

$$\frac{F_y}{F_{y_{max}}} + \frac{F_z}{F_{z_{max}}} + \frac{M_x}{M_{x_{max}}} + \frac{M_y}{M_{y_{max}}} + \frac{M_z}{M_{z_{max}}} \leq 1$$

Permissible forces and torques GK/-GA

Size	18	25	40	63
F _y _{max.} [N]	930	3080	7300	14050
F _z _{max.} [N]	930	3080	7300	14050
M _x _{max.} [Nm]	7	45	170	580
M _y _{max.} [Nm]	23	85	330	910
M _z _{max.} [Nm]	23	85	330	910

2nd moment of area

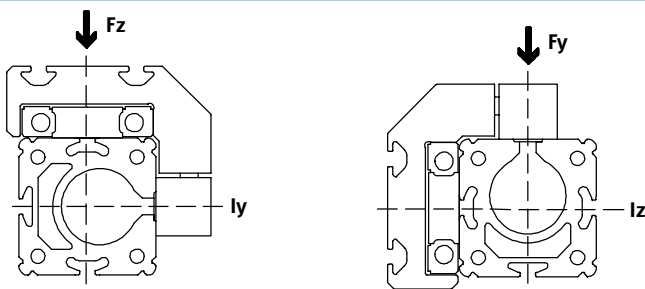

Size	18	25	40	63
l _y [mm ⁴]	172.3x10 ³	551x10 ³	1908x10 ³	13677x10 ³
l _z [mm ⁴]	73.7x10 ³	250x10 ³	875x10 ³	6987x10 ³



PtTool
design tool
www.festo.com/en/engineering

Spindle axes DGE-SP-KF, with recirculating ball bearing guide

Technical data

Characteristic load values for axis with extended slide GV

The indicated forces and torques refer to the centre of the guide rail. They must not be exceeded in the dynamic range. Special attention must be paid to the cushioning phase.

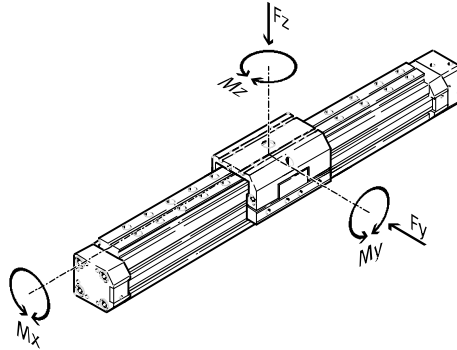

If the drive is subjected to more than two of the indicated forces and torques simultaneously, the following equations must be satisfied in addition to the indicated maximum loads:

$$\frac{F_y}{F_{y_{max}}} + \frac{F_z}{F_{z_{max}}} + \frac{M_x}{M_{x_{max}}} + \frac{M_y}{M_{y_{max}}} + \frac{M_z}{M_{z_{max}}} \leq 1$$

Permissible forces and torques					
Size		18	25	40	63
F _y _{max.}	[N]	930	3080	7300	14050
F _z _{max.}	[N]	930	3080	7300	14050
M _x _{max.}	[Nm]	7	45	170	580
M _y _{max.}	[Nm]	45	170	660	1820
M _z _{max.}	[Nm]	45	170	660	1820

2nd moment of area

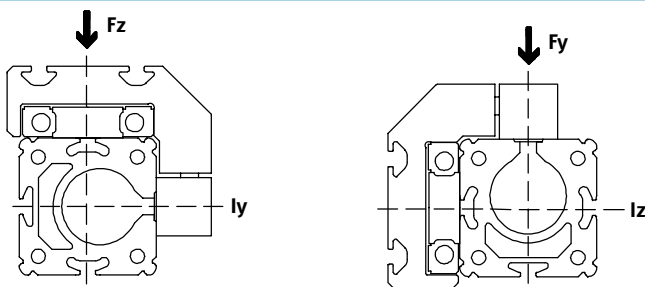

Size		18	25	40	63
l _y	[mm ⁴]	172.3x10 ³	551x10 ³	1908x10 ³	13677x10 ³
l _z	[mm ⁴]	73.7x10 ³	250x10 ³	875x10 ³	6987x10 ³

Spindle axes DGE-SP-KF, with recirculating ball bearing guide

Technical data



Stroke reserve

L12 The stroke reserve is a safety distance available on both sides of the axis in addition to the stroke.

L17 Slide length

L11 Internal mechanical stop

L1+ Overall length of axis

1 Working stroke

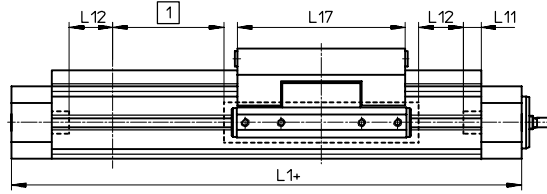

Example:

Type DGE-25-500-SP

Working stroke = 500 mm

Stroke reserve = (2x 10 mm)

= 20 mm

Total stroke = 500 mm + 20 mm

= 520 mm

Size	18	25	40	63
L12 per end position [mm]	6.5	10	20	30

Working stroke reduction with standard slide GK or extended slide GV and additional slide KL/KR

L17 = Slide/additional slide length

L18 = Distance between both slides

4 Additional slide

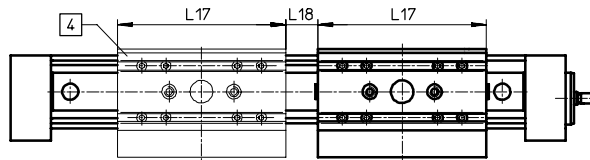

For a spindle axis with additional slide, the working stroke is reduced by the length of the additional slide and the distance between both slides.

Example:

Type DGE-25-500-SP-...-KF-GK-KL

Working stroke without

additional slide = 500 mm

L18 = 20 mm

L17 = 105 mm

Working stroke with

additional slide = 375 mm

(500 mm – 20 mm – 105 mm)

Working stroke reduction with standard slide GK with optional emergency buffer

2 Working stroke reduction

3 Emergency buffer

4 Shock absorber retainer

L12 Stroke reserve

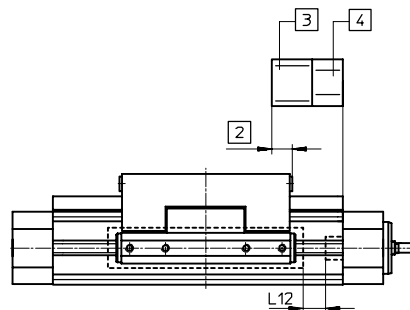

For a spindle axis with optional emergency buffer, the working stroke is reduced, as the stroke reserve is smaller than the overall dimensions of the emergency buffer and shock absorber retainer. The working stroke reduction varies depending on the size of the axis.

Size	18	25	40	63
Working stroke reduction [mm]	10	30	60	100

Spindle axes DGE-SP-KF, with recirculating ball bearing guide

Technical data

Maximum permissible support span l as a function of the force F

The axis may need to be supported with central supports in order to restrict deflection with long stroke lengths. The following diagrams serve to determine the maximum permissible support span l as a function of the force acting upon the axis F .

1 Force on the surface of the slide

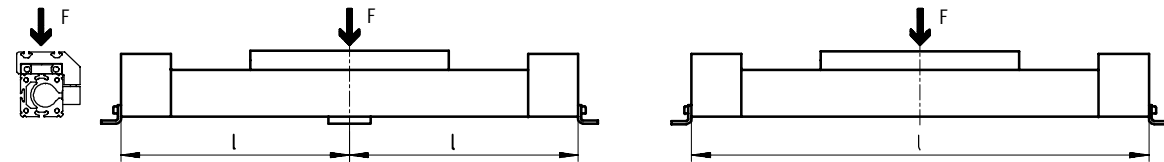

2 Force on the front of the slide

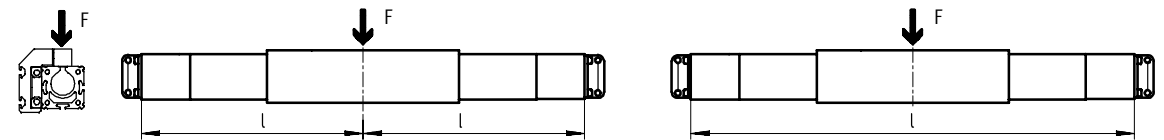

Maximum permissible support span l (without central support) as a function of the force F

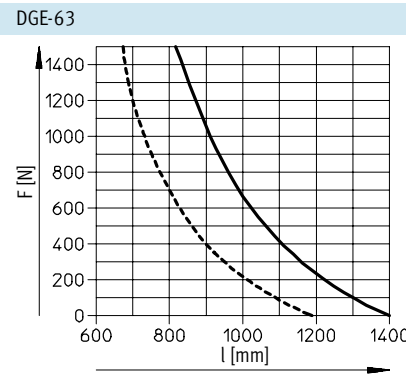
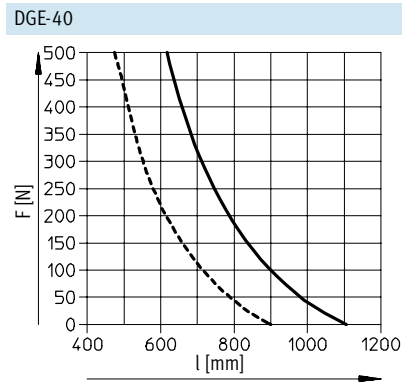
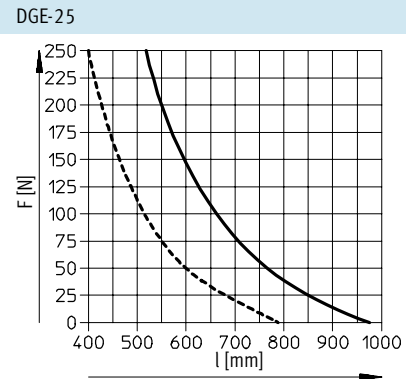
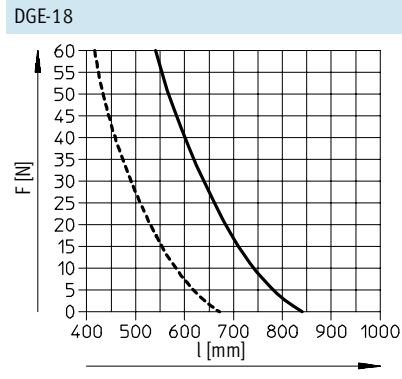

- 1
- - - 2

Spindle axes DGE-SP-KF, with recirculating ball bearing guide

Technical data



Maximum permissible speed v or drive rpm n as a function of the stroke l

DGE-18

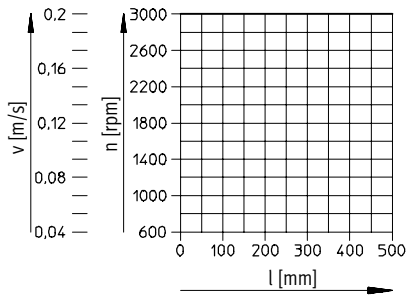

DGE-25

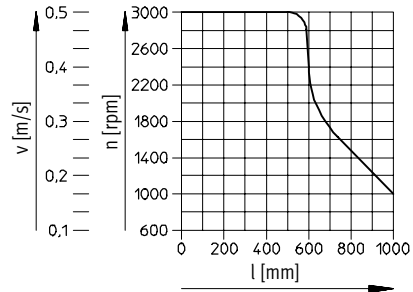

DGE-40

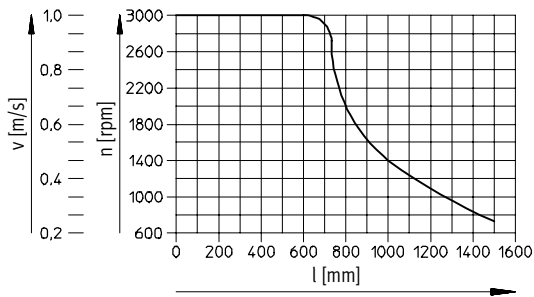

DGE-63

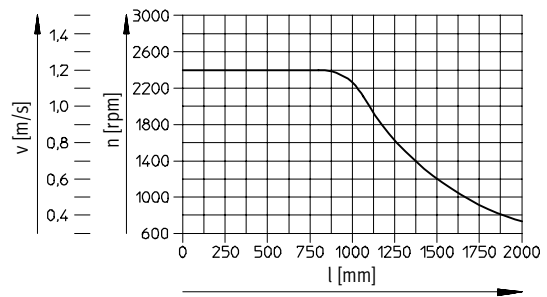

Spindle axes DGE-SP-KF, with recirculating ball bearing guide

Technical data



Dimensions Download CAD data → www.festo.com/en/engineering

Standard slide GK
Size 18

5 Hole for centring pin ZBS-5
 + = plus stroke length

Basic dimensions
→ 5 / 2.1-127

Additional slide KL/KR
Size 18

5 Hole for centring pin ZBS-5
6 Additional slide
 DGE-18-...-KL/KR
 + = plus stroke length

Extended slide GV
Size 18

2 Shock absorber retainer KYP
3 Emergency buffer NPE
5 Hole for centring pin ZBS-5
 + = plus stroke length

Profile
Size 18

2 Sensor slot for proximity sensor

Spindle axes DGE-SP-KF, with recirculating ball bearing guide

Technical data



Dimensions

Download CAD data → www.festo.com/en/engineering

Standard slide GK

Size 25 ... 63

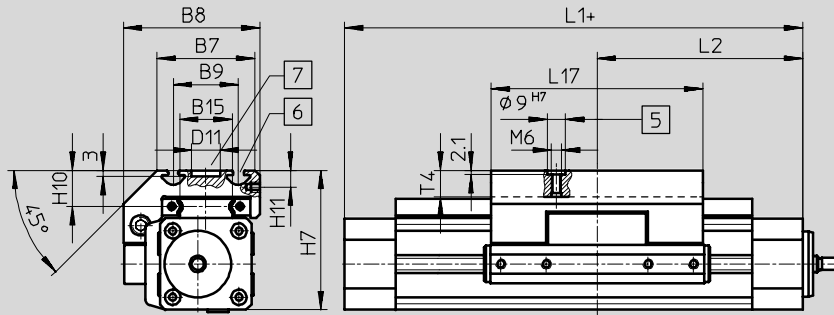

- 5 Hole for centring sleeve ZBH-9
- 6 Mounting slot for slot nut NSTL
- 7 Hole for central mounting SLZZ
- + = plus stroke length

Basic dimensions

→ 5 / 2.1-128

Size 40/63

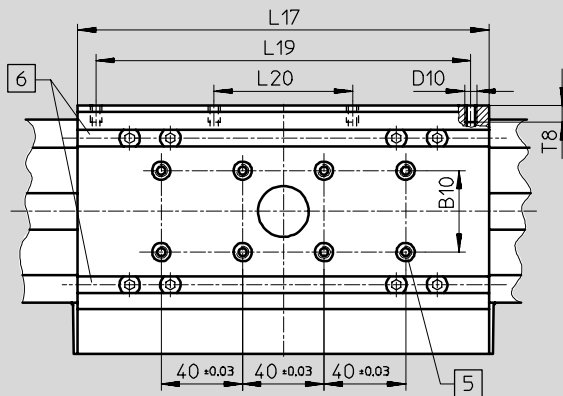

- 5 Hole for centring sleeve ZBH-9
- 6 Mounting slot for slot nut NSTL
- + = plus stroke length

Size 25 ... 63

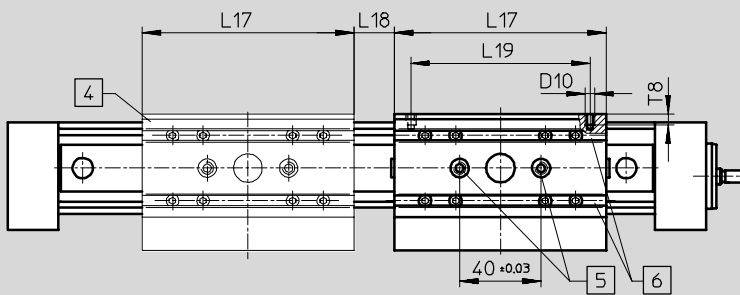

- 4 Additional slide
DGE-...-...-KL/KR
- 5 Hole for centring sleeve ZBH-9
- 6 Mounting slot for slot nut NSTL
- + = plus stroke length

Spindle axes DGE-SP-KF, with recirculating ball bearing guide

Technical data

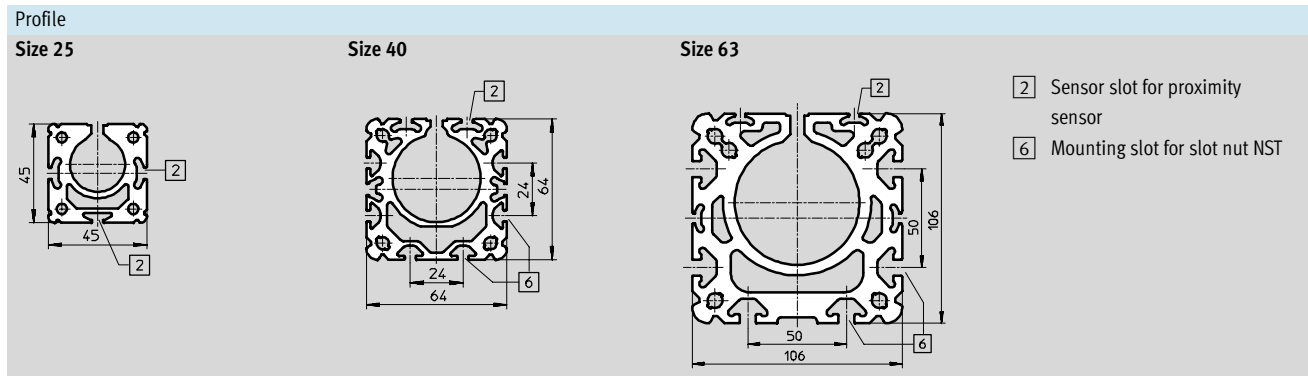

Size	B7	B8	B9 ±0.2	B10	B15	D10	D11 ∅ G7	H7	H10
25	48	67	32	–	23.5	M5	14	68.5	18.5
40	78.5	96.5	55	20	42	M5	25	90.5	20
63	121	142	90	40	71	M8	25	144.5	30

Size	H11	L1	L2	L17	L18 ¹⁾	L19 ±0.1	L20 ±0.1	T4 max.	T8
25	8.2	213	101.5	105	20	88	–	12.5	8.5
40	7	315	153	167	20	150	58	12.5	8.5
63	12.5	410	200	230	27	200	72	20.5	10.5

1) Recommended minimum distance for access to lubrication nipple

Spindle axes DGE-SP-KF, with recirculating ball bearing guide

Technical data



Dimensions

Download CAD data → www.festo.com/en/engineering

Extended slide GV

Size 25 ... 63

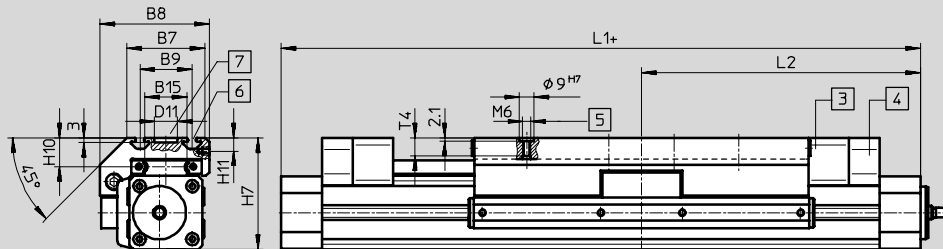

- 3 Emergency buffer NPE
 - 4 Shock absorber retainer KYP
 - 5 Hole for centring sleeve ZBH-9
 - 6 Slot for slot nut NSTL
 - 7 Hole for central mounting SLZZ
- + = plus stroke length

Basic dimensions
→ 5 / 2.1-128

Size 25

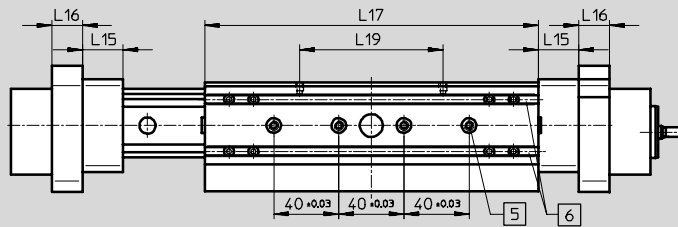

- 5 Hole for centring sleeve ZBH-9
 - 6 Mounting slot for slot nut NSTL
- + = plus stroke length

Size 40/63

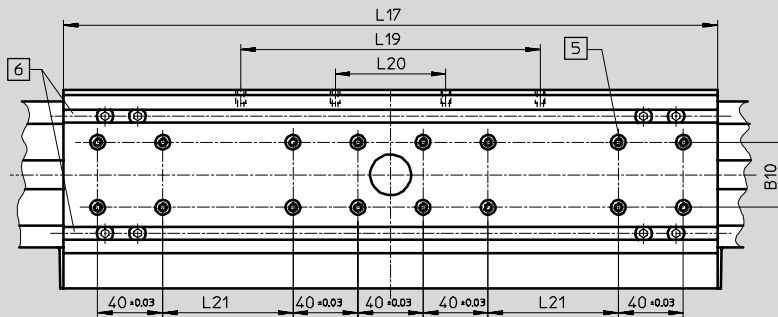

- 5 Hole for centring sleeve ZBH-9
 - 6 Mounting slot for slot nut NSTL
- + = plus stroke length

Spindle axes DGE-SP-KF, with recirculating ball bearing guide



Technical data

Size	B7	B8	B9 ±0.2	B10	B15	D10	D11 ∅ G7	H7	H10	H11
25	48	67	32	–	23.5	M5	14	68.5	18.5	8.2
40	78.5	96.5	55	20	42	M5	25	90.5	20	7
63	121	142	90	40	71	M8	25	144.5	30	12.5

Size	L1	L2	L15	L16	L17 ±0.2	L19 ±0.1	L20 ±0.1	L21 ±0.1	T4 max.	T8
25	343	171.5	25	19	205	88	–	–	12.5	8.5
40	545	271.5	40	32	337	150	58	40	12.5	8.5
63	760	380	60	44	480	200	72	120	20.5	10.5

Spindle axes DGE-SP-KF, with recirculating ball bearing guide

Technical data



Dimensions

Download CAD data → www.festo.com/en/engineering

Protected version GA

Size 25

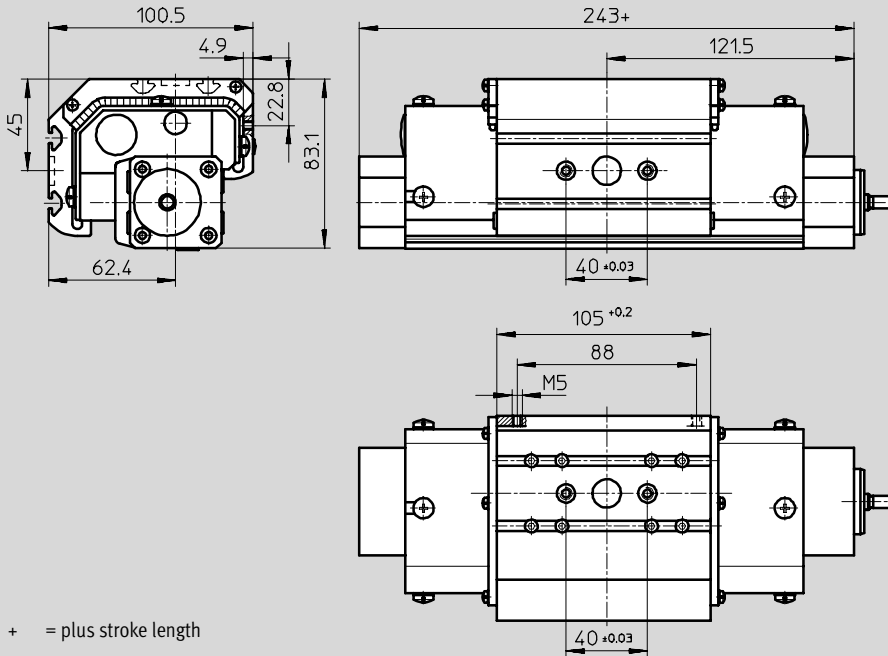

+ = plus stroke length

Size 40

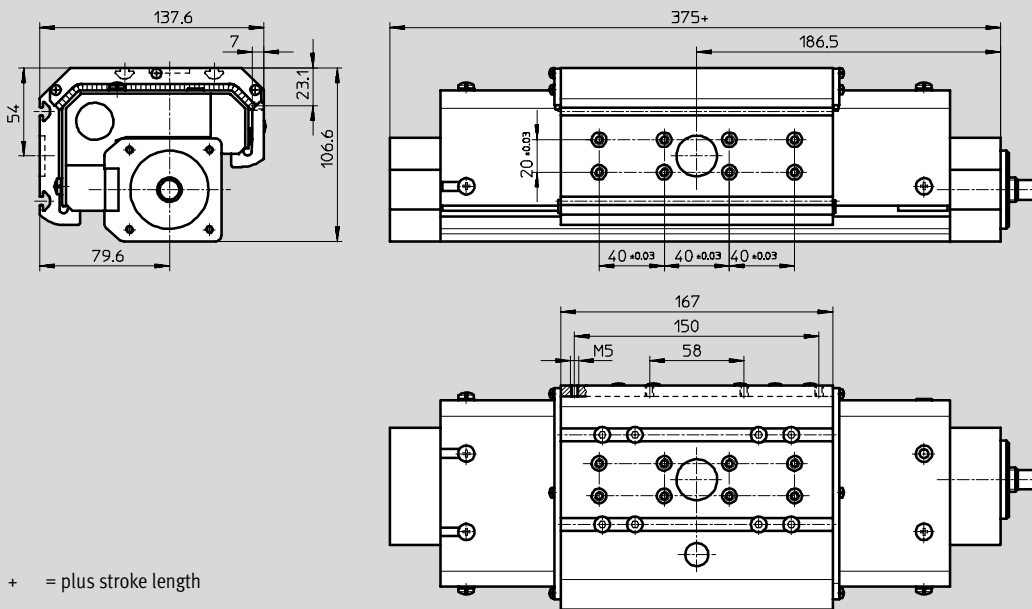

+ = plus stroke length

Spindle axes DGE-SP-KF, with recirculating ball bearing guide

Ordering data – Modular products

Order code

Mandatory data

Standard slide GK

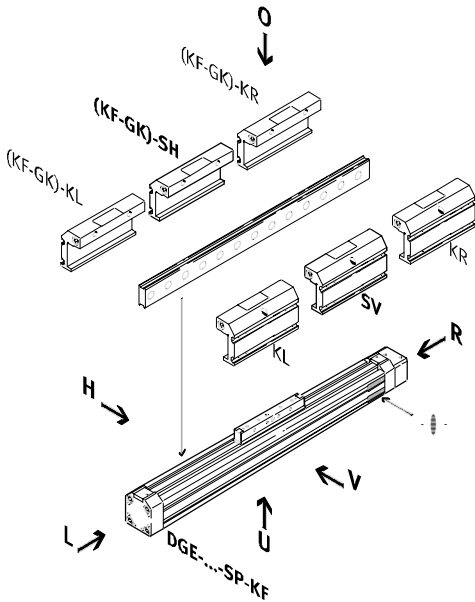

Extended slide GV

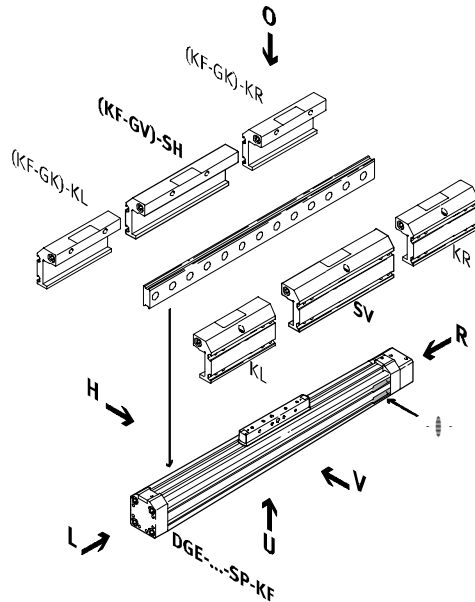

- KF Recirculating ball bearing guide
- KL Additional slide at left
- KR Additional slide at right
- SV Slide at front
- SH Slide at rear

- - Note

The insertion point for the proximity sensor is located on the right-hand side of the spindle drive
DGE-...-SP-KF

U = underneath
O = top
R = right
L = left
V = front
H = rear

Protected version GA

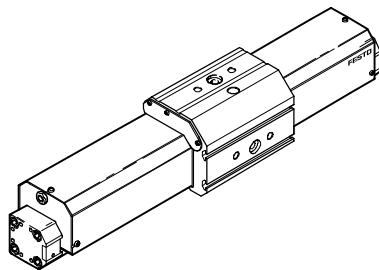

Spindle axes DGE-SP-KF, with recirculating ball bearing guide

Ordering data – Modular products

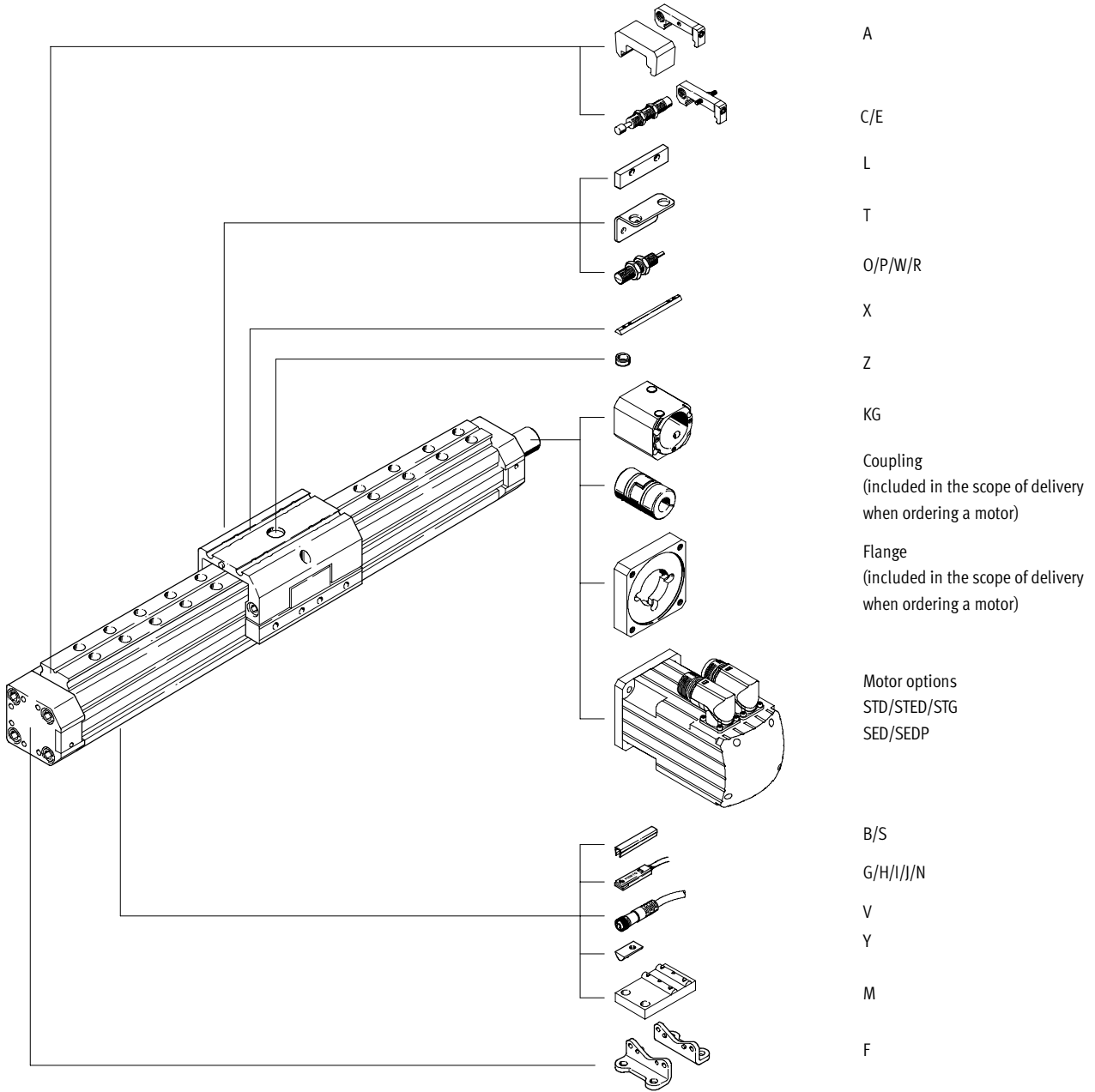

Spindle axes DGE-SP-KF, with recirculating ball bearing guide



Ordering data – Modular products

M Mandatory data					O Options		
Module No.	Design	Size	Stroke	Drive function	Coupling housing	Guide	Slide
193 745	DGE	18	1 ... 1 650	SP	KG LG	KF	GK GV GA
193 746		25					
193 747		40					
193 748		63					
Ordering example							
193 745	DGE	- 18	- 400	- SP	- KG	- KF	- GV

Ordering table									
Size	18	25	40	63	Condi- tions	Code	Enter code		
M Module No.	193 745	193 746	193 747	193 748					
Design	Electromechanical linear axis						DGE	DGE	
Size	18	25	40	63		-...			
Stroke [mm] Standard slide GK	100, 200, 300, 400, 500	100, 200, 300, 400, 500, 600, 700, 800, 900, 1000	200, 300, 400, 500, 600, 800, 1000, 1200, 1400, 1500	300, 400, 500, 600, 800, 1000, 1200, 1400, 1500, 1800, 2000		-...			
	-	1 ... 1000	1 ... 1500	1 ... 2000					
	Extended slide GV	110, 210, 310, 410	170, 270, 370, 470, 570, 670, 770, 870	170, 270, 370, 570, 770, 970, 1170, 1270	150, 250, 450, 650, 850, 1050, 1150, 1450, 1650		-...		
		-	1 ... 870	1 ... 1270	1 ... 1650				
Protected version GA	-	170, 270, 370, 470, 570, 670, 770, 870, 970	140, 240, 340, 440, 540, 740, 940, 1140, 1340, 1440	-		-...			
	-	1 ... 970	1 ... 1440	-					
	-	-	-	-					
Drive function	Electromechanical drive with ball screw						-SP	-SP	
O Coupling housing	Coupling housing					-KG			
	-	-	Attached, large design	-		-LG			
Guide	Recirculating ball bearing guide					1	-KF	-KF	
Slide Standard	Standard					2	-GK		
	Extended					2	-GV		
Dust protection	Dust-proof version			-	2	-GA			

1 KF Only with slide GK, GV, GA.

2 GK, GV, GA Only with slide attachment position SV, SH.

Transfer order code

Spindle axes DGE-SP-KF, with recirculating ball bearing guide

Ordering data – Modular products



Options

Slide attachment position	Additional slide	Type of motor	Brake
SV SH	KL KR	STD STED STG SED SEDP	BR
- SV	-	- SED	- BR

Electrical positioning systems
Electromechanical drives

2.1

Ordering table		18	25	40	63	Condi- tions	Code	Enter code		
Slide attachment position	Slide at front						-SV			
	Slide at rear						-SH			
Additional left slide (effective stroke reduction)	Standard slide at left (85 mm)	(105 mm)	(167 mm)	(230 mm)		3	-KL			
	Standard slide at right (85 mm)	(105 mm)	(167 mm)	(230 mm)		3	-KR			
Type of motor	Stepper motor	Stepper motor				-	4 5	-STD		
		with integrated power electronics				-	-	-	4 5	-STED
		-				-	-	-	4	-STG
	Servo motor	Servo motor				-	-	-	4 6	-SED
-				for high performance	-	-	4 5	-SEDP		
Brake	Motor brake					7	-BR			

3 **KL, KR** Not with slide GA.

4 **STD, STED, STG, SED, SEDP**

For sizes 18, 25, 63 only with coupling housing KG.

5 **STD, STED, SEDP**

For size 40 only with coupling housing LG.

6 **SED**

For size 40 only with coupling housing KG.

7 **BR**

Only permissible with motor type.

Allocation of order codes to motor types

→ from 5 / 2.1-168

The motor controller and cable set must be ordered separately.

Stepper motor → 5 / 2.2-2

Servo motor → 5 / 2.2-16

Transfer order code

- - - -

Spindle axes DGE-SP-KF, with recirculating ball bearing guide

Ordering data – Modular products



Options												
Accessories	Slot cover	Slot nut	Central support	Foot mounting	Emergency buffer and retainer	Shock absorber	Centring pins/sleeves	Proximity sensor	Plug socket	Sensor bracket	Switching lug	Inductive sensor
ZUB	...S ...B	...Y ...X	...M	...F	...A	...C ...E	...Z	...G ...H ...I ...J ...N	...V	...T	L	...O ...P ...W ...R
ZUB	- 2S	10Y		F				2G				

Ordering table											
Size	18	25	40	63	Conditions	Code	Enter code				
Accessories	Supplied separately						ZUB-		ZUB-		
Slot cover	Sensor slot	1 ... 10					...S				
	Mounting slot	-	-	1 ... 10			...B				
Slot nut	for mounting slot	1 ... 10					...Y				
	for slide	-	1 ... 10				...X				
Central support	1 ... 10					...M					
Foot mounting (kit)	1 ... 10					...F					
Emergency buffer and retainer for KF	(effective stroke reduction with emergency buffer at both ends)	(10 mm)	(30 mm)	(60 mm)	(100 mm)	⁹	...A				
		1 ... 2						...C			
		1 ... 2						...E			
		-									
Shock absorber and retainer for KF-GK, KF-GV for KF-GA	1 ... 2						...C				
	-						...E				
Centring pins/sleeves (pack of 10)	10, 20, 30, 40, 50, 60, 70, 80, 90						...Z				
Proximity sensor	with cable, 2.5 m	1 ... 10					...G				
	with plug	1 ... 10					...H				
	contactless with cable, 2.5 m	1 ... 10					...I				
	contactless, plug	1 ... 10					...J				
	NC contact with cable, 2.5 m	1 ... 10					...N				
Plug socket with cable, 2.5 m	1 ... 10					...V					
Sensor bracket for inductive sensors	1 ... 5					...T					
Switching lug	1					L					
Inductive sensor	NO contact, cable	1 ... 5					...O				
	NC contact, cable	1 ... 5					...P				
	NO contact, plug	1 ... 5					...W				
	NC contact, plug	1 ... 5					...R				

⁹ **A** Only with slide GK.
Mounted as standard for slide GV, GA

¹¹ **E** Only with slide GA.

¹⁰ **C, T, L, O, P, W, R.**
Not with slide GA.

Transfer order code

ZUB -

Spindle axes DGE-SP-HD, with heavy-duty guide

Peripherals overview

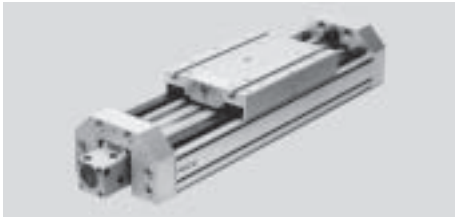

Electrical positioning systems
Electromechanical drives

2.1

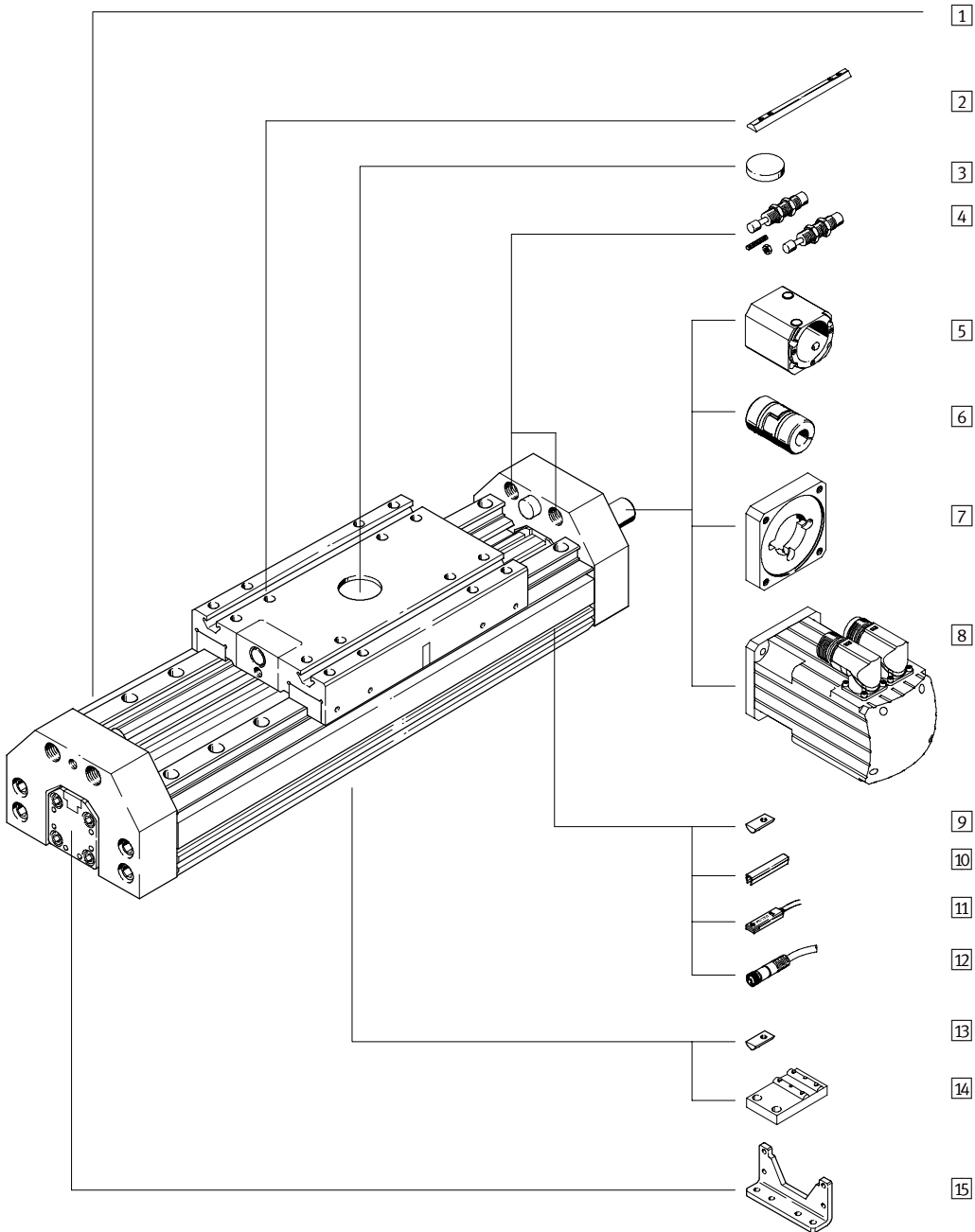

Spindle axes DGE-SP-HD, with heavy-duty guide

Peripherals overview



Variants and accessories		
Type	Brief description	→ Page
1 Spindle axis DGE-SP-HD	Electromechanical axis with heavy-duty guide	5 / 2.1-156
2 Slot nut for slide X	For mounting loads and attachments on the slide	5 / 2.1-175
3 Centring disc Q	For centring loads and attachments on the slide	5 / 2.1-175
4 Shock absorber kits D	For avoiding damage at the end stop in the event of malfunction	5 / 2.1-174
5 Coupling housing KG	Adapter for mounting the motor on the axis	5 / 2.1-168
6 Coupling KSE	Connecting element between axis and motor	5 / 2.1-168
7 Motor flange MTR-FL	Connecting element between coupling housing and motor	5 / 2.1-168
8 Motor MTR	Motors specially matched to the axis, with or without gearing, with or without brake	5 / 2.1-168
9 Slot nut for mounting slot Y	For mounting attachments	5 / 2.1-175
10 Slot cover B/S	For protecting against the ingress of dirt	5 / 2.1-175
11 Proximity sensor G/H/I/J/N	For use as a signal generator and safety monitoring	5 / 2.1-177
12 Plug socket with cable V	For proximity sensors	5 / 2.1-177
13 Slot nut for HD underneath U	For mounting attachments	5 / 2.1-175
14 Central support M	For mounting the axis	5 / 2.1-171
15 Foot mounting F	For mounting the axis	5 / 2.1-171

Spindle axes DGE-SP-HD, with heavy-duty guide

Type code



		DGE	-	25	-	500	-	SP	-	KG	-	HD	-	GK	-	SED	-	
Type																		
DGE	Spindle axis																	
Size																		
Stroke [mm]																		
Drive function																		
SP	Spindle																	
Coupling housing																		
KG	Coupling housing																	
LG	Attached, large design																	
Guide																		
HD	Heavy-duty guide																	
Slide length																		
GK	Standard slide																	
Type of motor																		
STD	Stepper motor																	
STED	Stepper motor with integrated power electronics																	
SED	Servo motor																	
SEDP	Servo motor for high performance																	
Motor brake																		
BR	Brake																	

Spindle axes DGE-SP-HD, with heavy-duty guide

Type code



		+ ZUB	-			F		Q	2H	2V
Accessories										
ZUB	Accessories supplied loose									
Slot cover										
...S	Sensor slot									
...B	Mounting slot									
Slot nut										
...Y	For mounting slot									
...X	For slide									
...U	For HD underneath									
Central support										
...M	Central support									
Foot mounting										
...F	Foot mounting									
Shock absorber										
...D	Kit for HD									
Central mounting										
...Q	Central mounting									
Proximity sensor										
...G	With cable, 2.5 m									
...H	With plug									
...I	Contactless with cable, 2.5 m									
...J	Contactless, plug									
...N	NC contact with cable, 2.5 m									
Plug socket										
...V	With cable, 2.5 m									

Spindle axes DGE-SP-HD, with heavy-duty guide

Technical data



- \varnothing - Size
18 ... 40
- | - Stroke length
100 ... 1500 mm

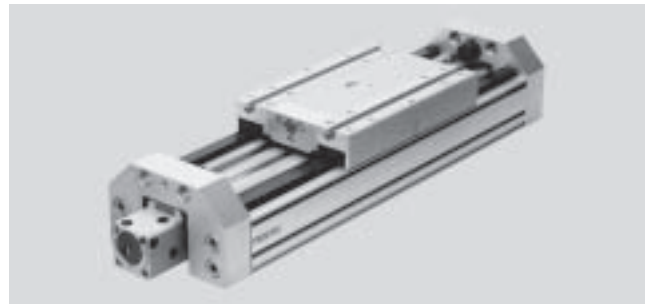

Electrical positioning systems
Electromechanical drives
2.1

General technical data				
Size	18-HD18	25-HD25	25-HD40	40-HD40
Constructional design	Electromechanical axis with heavy-duty guide			
Guide	Recirculating ball bearing guide			
Mounting position	Any			
Max. working stroke [mm]	100 ... 400	100 ... 900	100 ... 900	200 ... 1500
Max. working load [kg]	6	25	25	50
Max. feed force F_x [N]	140	250	250	600
Max. driving torque [Nm]	0.1	0.45	0.45	2.1
No-load torque ¹⁾ [Nm]	0.05	0.2	0.2	0.6
Max. speed [m/s]	0.2	0.5	0.5	1
Repetition accuracy [mm]	±0.02			

1) Measured at a speed of 0.2 m/s

Operating and environmental conditions				
Size	18-HD18	25-HD25	25-HD40	40-HD40
Ambient temperature [°C]	0 ... +40			
Protection class	IP40			

Weights [kg]				
Size	18-HD18	25-HD25	25-HD40	40-HD40
Basic weight with 0 mm stroke ¹⁾	4.31	7.04	16.13	19.02
Additional weight per 100 mm stroke	0.32	1.6	2.19	2.62

1) Including coupling housing and slide

Mass moment of inertia				
Size	18-HD18	25-HD25	25-HD40	40-HD40
J_0 [kg cm ²]	0.013	0.086	0.375	0.698
J_H per metre stroke [kg cm ² /m]	0.031	0.121	0.121	1
J_L per kg working load [kg cm ² /kg]	0.005	0.025	0.025	0.101

The mass moment of inertia J_A of the entire axis is calculated as follows:

$$J_A = J_0 + J_H \times \text{working stroke [m]} + J_L \times m_{\text{working load [kg]}}$$

Spindle axes DGE-SP-HD, with heavy-duty guide

Technical data

Spindle		18-HD18	25-HD25	25-HD40	40-HD40
Size		18-HD18	25-HD25	25-HD40	40-HD40
Diameter	[mm]	8	12	12	20
Pitch	[mm/rev.]	4	10	10	20

Materials

Sectional view

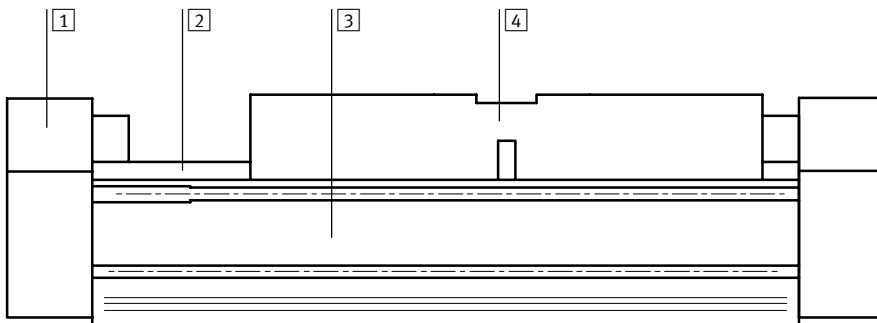

Axis		
1	End cap	Anodised aluminium
2	Guide	Rolled steel
3	Profile	Anodised aluminium
4	Slide	Anodised aluminium

Spindle axes DGE-SP-HD, with heavy-duty guide

Technical data



Characteristic load values

The indicated forces and torques refer to the centre of the heavy-duty guide.

They must not be exceeded in the dynamic range. Special attention must be paid to the cushioning phase.

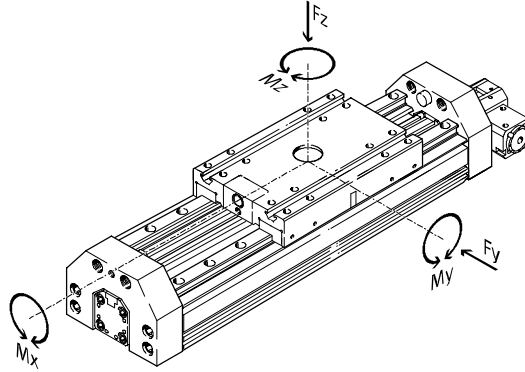

If the drive is subjected to more than two of the indicated forces and torques simultaneously, the following equations must be satisfied in addition to the indicated maximum loads:

$$\frac{F_y}{F_{y_{max}}} + \frac{F_z}{F_{z_{max}}} + \frac{M_x}{M_{x_{max}}} + \frac{M_y}{M_{y_{max}}} + \frac{M_z}{M_{z_{max}}} \leq 1$$

Permissible forces and torques

Size		18-HD18	25-HD25	25-HD40	40-HD40
F _y _{max.}	[N]	1820	5400	5400	5400
F _z _{max.}	[N]	1820	5600	5600	5600
M _x _{max.}	[Nm]	70	260	375	375
M _y _{max.}	[Nm]	115	415	560	560
M _z _{max.}	[Nm]	112	400	540	540



PtTool
design tool
www.festo.com/en/engineering

Spindle axes DGE-SP-HD, with heavy-duty guide

Technical data



Maximum permissible support span l as a function of the force F

The drive may need to be supported in order to restrict deflection with long stroke lengths. The following diagrams serve to determine the

maximum permissible support span l as a function of the force acting upon the axis F .

Force on the surface of the slide

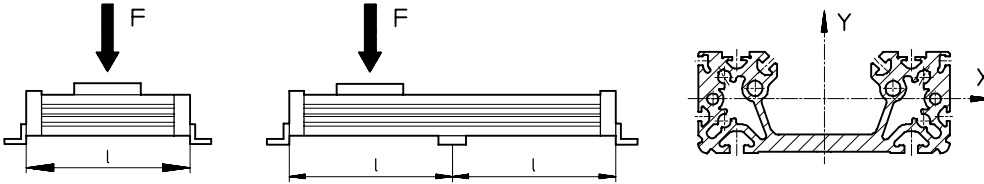

Maximum permissible support span l (without central support) as a function of the force F

Deflection around the X axis

Deflection around the Y axis

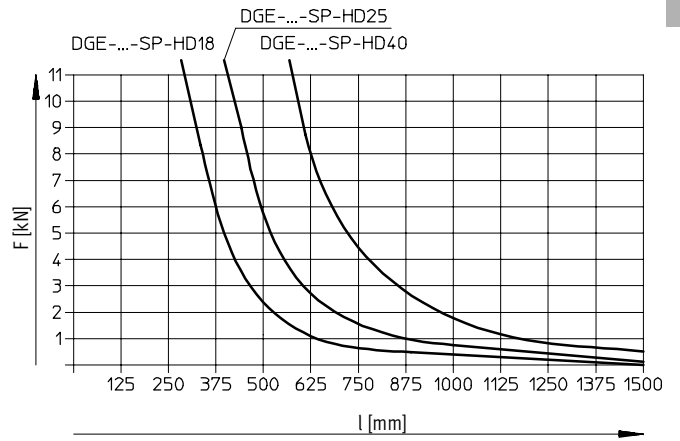
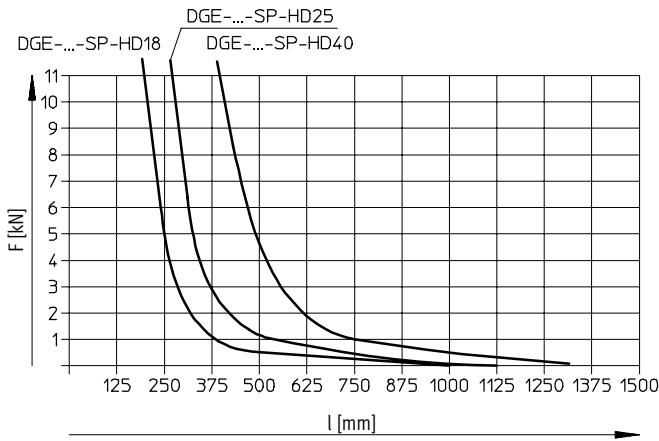

Spindle axes DGE-SP-HD, with heavy-duty guide

Technical data



2.1

Dimensions Download CAD data → www.festo.com/en/engineering

1 Mounting slot for slot nut NSTH 5 Slot nut NSTH 8 Rubber buffer
 4 Hole for central mounting SLZZ 6 Thread for shock absorber 9 Dimension for motor connection on one side
 7 Thread for threaded pin

+ = plus stroke length

Profile

2 Mounting slot for slot nut NST
 3 Sensor slot for proximity sensor

Size	B1	B2	B3	B4	D1	D2	D3	D4	D5	H1	H2	H3	H4
		±0,2					∅ G7						
18-HD18	80±0,3	85	116	40	M5	M12x1	25	M6	M5	70	12.8	19.5±0,1	14
25-HD-25	100±0,3	114	144	48	M8	M16x1	25	M8	G1/8	93.5	18.5	25±0,2	21
25-HD40	140±0,35	156	185	54	M8	M22x1.5	25	M8	G1/8	124.5	21	48±0,2	35
40-HD40	140±0,35	156	185	54	M8	M22x1.5	25	M8	G1/4	124.5	21	48±0,2	35

Size	H5	H6	H7	H8	H9	H10	H11	L1	L2	L4	L5	L8	T1	X
18-HD18	42.3	5.9	8.7	20x45°	68	0.8	30.3	240	120	15	25	160	3.5	49
25-HD25	52.8	9	9.8	30x45°	90	2	37	310	155	15	35	210	3.5	3
25-HD40	82.8	5.5	15.5	35x45°	120	2	63	354	177	15	32	260	4	-
40-HD40	82.8	5.5	15.5	35x45°	120	2	52.5	354	177	15	32	260	4	-7

Spindle axes DGE-SP-HD, with heavy-duty guide

Ordering data – Modular products

Order code
Mandatory data

Heavy-duty guide HD

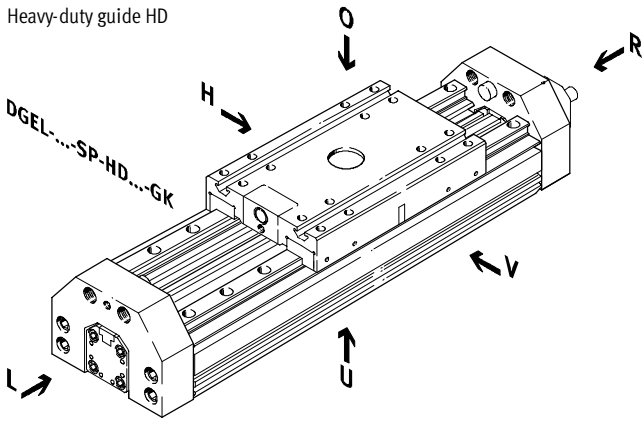

-  - Note

The insertion point for the proximity sensor is located on the right-hand side of the heavy-duty guide

- U = underneath
- O = top
- R = right
- L = left
- V = front
- H = rear

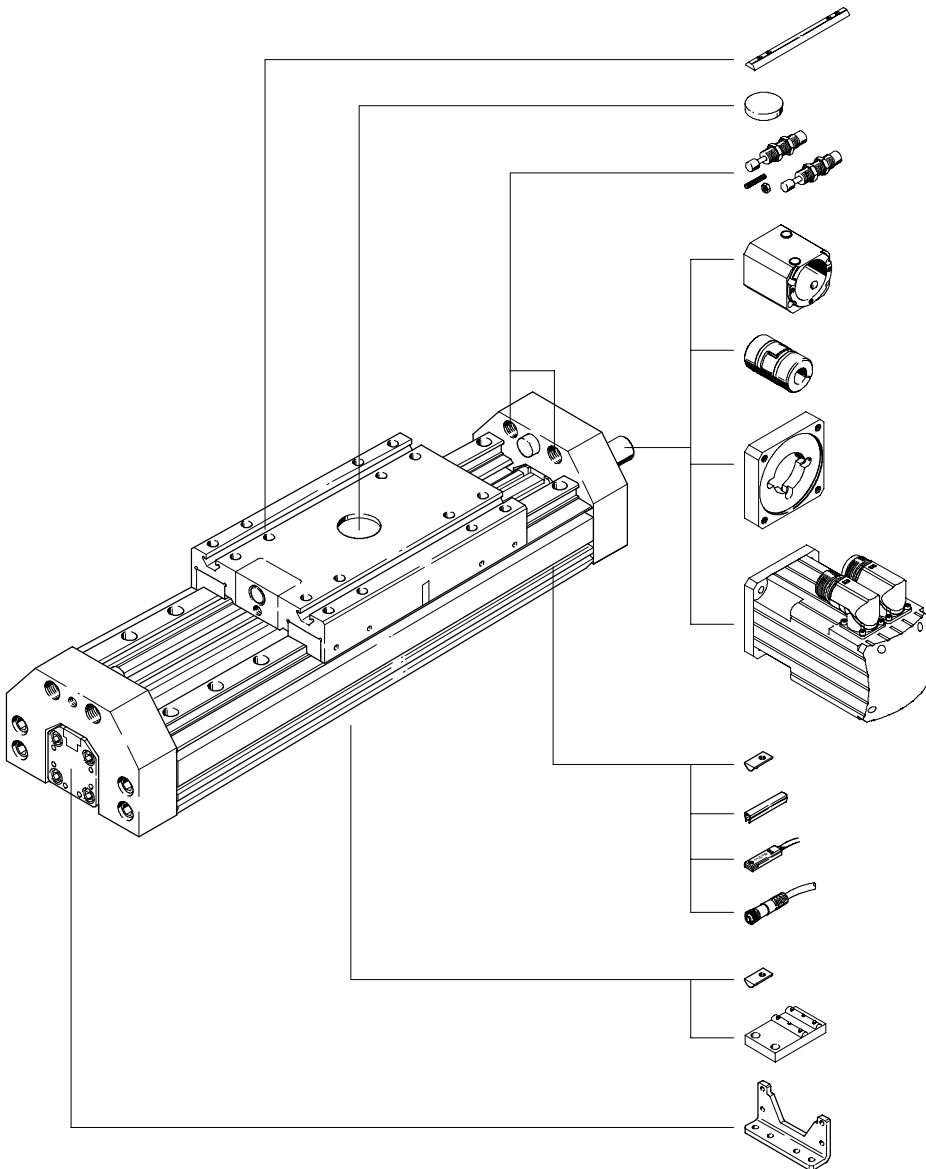

X

Q

D

KG

Coupling
(included in the scope of delivery when ordering a motor)

Flange
(included in the scope of delivery when ordering a motor)

Motor options
SED/SEDP/SEG/SEI/SEIP
STD/STED/STDP/STG

Y

B/S

G/H/I/J/N

V

Y

M

F

Spindle axes DGE-SP-HD, with heavy-duty guide

Ordering data – Modular products



M Mandatory data					O Options →		
Module No.	Design	Size	Stroke	Drive function	Coupling housing	Guide	Slide
193 745 193 746 193 747	DGE	18 25 40	1 ... 1 500	SP	KG LG	HD18 HD25 HD40	GK
Ordering example							
193 747	DGE	- 40	- 800	- SP	- KG	- HD40	- GK

Ordering table							
Size	18	25	40	Condi- tions	Code	Enter code	
M Module No.	193 745	193 746	193 747				
Design	Electromechanical linear axis				DGE		DGE
Size	18	25	40		-...		
Stroke [mm]	100, 200, 300, 400	100, 200, 300, 400, 500, 600, 700, 800, 900	200, 300, 400, 500, 600, 800, 1000, 1200, 1400, 1500		-...		
	-	1 ... 900	1 ... 1500				
Drive function	Electromechanical drive with ball screw				-SP		-SP
O Coupling housing	Coupling housing				-KG		
	-	-	Attached, large design		-LG		
Guide	Heavy-duty guide HD18	-	-		-HD18		-HD...
	-	Heavy-duty guide HD25	-		-HD25		
	-	Heavy-duty guide HD40	Heavy-duty guide HD40		-HD40		
↓ Slide	Standard				-GK		-GK

Transfer order code

	DGE	-		-		-	SP	-		-	HD...	-	GK
--	-----	---	--	---	--	---	----	---	--	---	-------	---	----

Spindle axes DGE-SP-HD, with heavy-duty guide

Ordering data – Modular products



Options →

Type of motor

STD
STED
SED
SEDP

- **SED**

Brake

BR

- **BR**

Ordering table							
Size	18	25	40	Condi- tions	Code	Enter code	
↓ 0 Type of motor	Stepper motor	Stepper motor		1 2	-STD		
		with integrated power electronics		1 2	-STED		
	Servo motor	Servo motor		1 3	-SED		
		for high performance		1 2	-SEDP		
↓ Brake	Motor brake		4	-BR			

1 **STD, STED, SED, SEDP**

For sizes 18 and 25 only with coupling housing KG.

2 **STD, STED, SEDP**

For size 40 only with coupling housing LG.

3 **SED**

For size 40 only with coupling housing KG.

4 **BR**

Only permissible with motor type.

Allocation of order codes to motor types
→ from 5 / 2.1-168

The motor controller and cable set must be ordered separately.
Stepper motor → 5 / 2.2-2
Servo motor → 5 / 2.2-16

Transfer order code

- [] - []

Spindle axes DGE-SP-HD, with heavy-duty guide

Ordering data – Modular products



Options								
Accessories	Slot cover	Slot nut	Central support	Foot mounting	Shock absorber	Central mounting	Proximity sensor	Plug socket
ZUB	...S ...B	...Y ...X ...U	...M	...F	...D	...Q	...G ...H ...I ...J ...N	...V
ZUB	2SB	10Y2X	M	F		Q	2J	2V

Ordering table						
Size	18	25	40	Condi- tions	Code	Enter code
Accessories	Supplied separately				ZUB-	ZUB-
Slot cover	Sensor slot	1 ... 10			...S	
	Mounting slot	1 ... 10			...B	
Slot nut	for mounting slot	1 ... 10			...Y	
	for slide	1 ... 10			...X	
	for HD underneath	1 ... 10			...U	
Central support	1 ... 10				...M	
Foot mounting (kit)	1 ... 10				...F	
Shock absorber	Kit for HD	1 ... 2			...D	
Central mounting	1 ... 10				...Q	
Proximity sensor	with cable, 2.5 m	1 ... 10			...G	
	with plug	1 ... 10			...H	
	contactless with cable, 2.5 m	1 ... 10			...I	
	contactless, plug	1 ... 10			...J	
	NC contact with cable, 2.5 m	1 ... 10			...N	
Plug socket	with cable, 2.5 m	1 ... 10			...V	

Transfer order code

ZUB -

Spindle axes DGE

Application example

FESTO

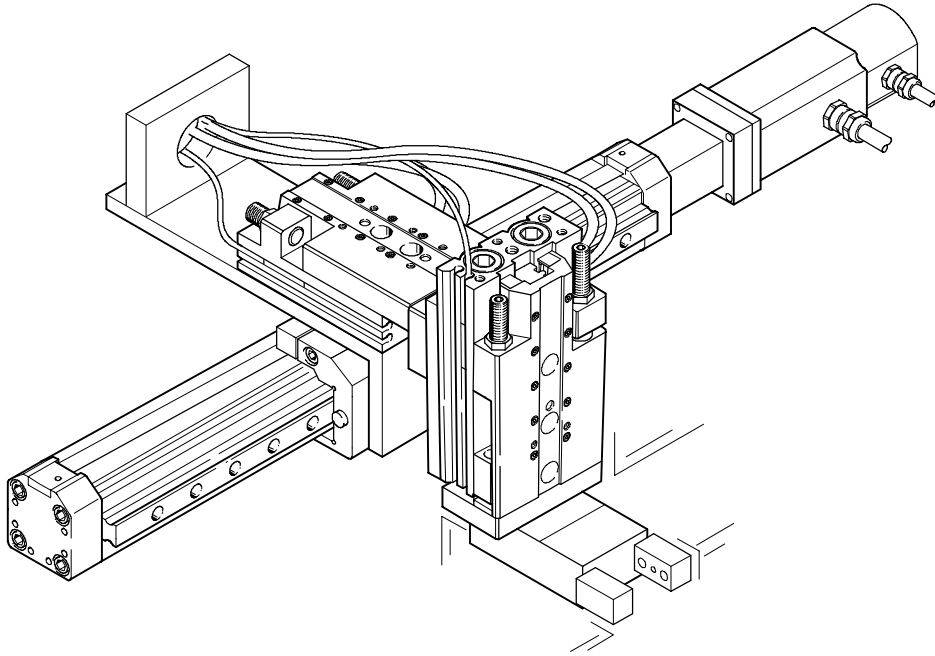

Triple axis application



Spindle axes DGE

Accessories

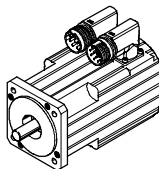
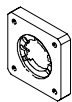
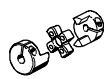

Permissible axis and servo motor combinations								
Order code	Servo motor		Motor flange		Coupling		Coupling housing	
DGE-SP DGE-SP-KF DGE-SP-HD								
	Part No.	Type	Part No.	Type	Part No.	Type	Part No.	Type
For DGE-18								
	without gearing/without brake							
SED	526 723	MTR-AC-55-3S-AA	529 946	MTR-FL28-AC55	529 953	KSE-15-D05-D09	170 374	DGE-KG-18-SP-FL28
	without gearing/with brake							
SED + BR	526 724	MTR-AC-55-3S-AB	529 946	MTR-FL28-AC55	529 953	KSE-15-D05-D09	170 374	DGE-KG-18-SP-FL28
For DGE-25								
	without gearing/without brake							
SED	526 723	MTR-AC-55-3S-AA	529 942	MTR-FL44-AC55	530 941	KSE-30-D06-D09	124 631	DGE-KG-25-SP-FL44
	without gearing/with brake							
SED + BR	526 724	MTR-AC-55-3S-AB	529 942	MTR-FL44-AC55	530 941	KSE-30-D06-D09	124 631	DGE-KG-25-SP-FL44
For DGE-40								
	without gearing/without brake							
SED	526 727	MTR-AC-70-3S-AA	529 943	MTR-FL44-AC70	123 051	KSE-30-D11-D12	124 632	DGE-KG-40-SP-FL44
SEDP	526 731	MTR-AC-100-3S-AA	529 947	MTR-FL64-AC100	529 952	KSE-40-D12-D19	529 940	DGE-KG-40-SP-FL64
	without gearing/with brake							
SED + BR	526 728	MTR-AC-70-3S-AB	529 943	MTR-FL44-AC70	123 051	KSE-30-D11-D12	124 632	DGE-KG-40-SP-FL44
SEDP + BR	526 732	MTR-AC-100-3S-AB	529 947	MTR-FL64-AC100	259 952	KSE-40-D12-D19	529 940	DGE-KG-40-SP-FL64
For DGE-63								
	with integrated gearing/without brake							
SED	526 735	MTR-AC-100-5S-AA	529 947	MTR-FL64-AC100	123 847	KSE-40-D19-D20	529 941	DGE-KG-63-SP-FL64
	with integrated gearing/with brake							
SED + BR	526 736	MTR-AC-100-5S-AB	529 947	MTR-FL64-AC100	123 847	KSE-40-D19-D20	529 941	DGE-KG-63-SP-FL64

 Note
 The reduction ratio of the gearing is 4 : 1. Technical data for servo motors → 5 / 2.2-16

Spindle axes DGE

Accessories



Permissible axis and stepper motor combinations								
Order code	Stepper motor		Motor flange		Coupling		Coupling housing	
DGE-SP DGE-SP-KF DGE-SP-HD								
	Part No.	Type	Part No.	Type	Part No.	Type	Part No.	Type
For DGE-18								
	without gearing/without brake							
STD	530 057	MTR-ST-42-48S-AA	530 080	MTR-FL28-ST42	530 085	KSE-15-D05-D05	170 374	DGE-KG-18-SP-FL28
STED	530 059	MTRE-ST-42-48S-AA	530 080	MTR-FL28-ST42	530 085	KSE-15-D05-D05	170 374	DGE-KG-18-SP-FL28
	without gearing/with brake							
STD + BR	530 058	MTR-ST-42-48S-AB	530 080	MTR-FL28-ST42	530 085	KSE-15-D05-D05	170 374	DGE-KG-18-SP-FL28
STED + BR	530 060	MTRE-ST-42-48S-AB	530 080	MTR-FL28-ST42	530 085	KSE-15-D05-D05	170 374	DGE-KG-18-SP-FL28
For DGE-25								
	without gearing/without brake							
STD	530 061	MTR-ST-57-48S-AA	530 081	MTR-FL44-ST57	530 087	KSE-30-D06-D06,35	124 631	DGE-KG-25-SP-FL44
	without gearing/with brake							
STD + BR	530 062	MTR-ST-57-48S-AB	530 081	MTR-FL44-ST57	530 087	KSE-30-D06-D06,35	124 631	DGE-KG-25-SP-FL44
For DGE-40								
	without gearing/without brake							
STD	530 065	MTR-ST-87-48S-AA	533 140	MTR-FL64-ST87	525 864	KSE-40-D11-D12	529 940	DGE-KG-40-SP-FL64
	without gearing/with brake							
STD + BR	530 066	MTR-ST-87-48S-AB	533 140	MTR-FL64-ST87	525 864	KSE-40-D11-D12	529 940	DGE-KG-40-SP-FL64
For DGE-63								
	with integrated gearing/without brake							
STG	530 067	MTR-ST-87-48S-GA	533 139	MTR-FL64-PL80	123 849	KSE-40-D20-D20	529 941	DGE-KG-63-SP-FL64
	with integrated gearing/with brake							
STG + BR	530 068	MTR-ST-87-48S-GB	533 139	MTR-FL64-PL80	123 849	KSE-40-D20-D20	529 941	DGE-KG-63-SP-FL64

Note
 The reduction ratio of the gearing is 4 : 1. Technical data for stepper motors
 → 5 / 2.2-16

Electrical positioning systems
 Electromechanical drives
2.1

Spindle axes DGE

Accessories



Foot mounting HP (order code F)

Material:
Galvanised steel
Free of copper, PTFE and silicone



HP-25

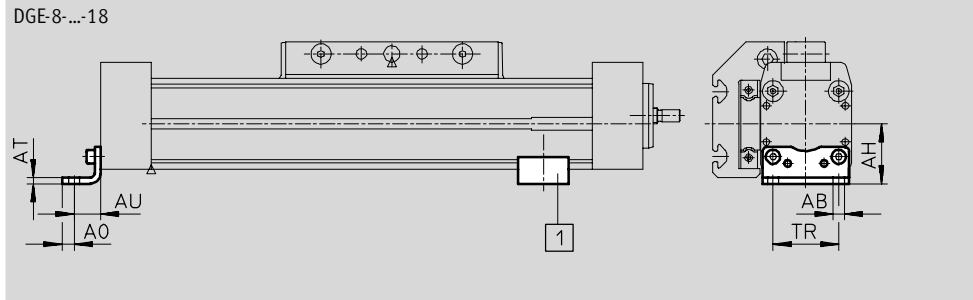

Dimensions and ordering data										
for size	AB Ø	AH	AO	AT	AU	TR	Weight [g]	Part No.	Type	
18	5.5	24	4.8	3	13.3	24	70	158 472	HP-18	
25	5.5	29.5	6	3	13	32.5	61	150 731	HP-25	
40	6.6	46	8.5	5	17.5	45	188	150 733	HP-40	
63	11	69	13.5	6	28	75	305	150 735	HP-63	

Central support MUP (order code M)

Material:
Galvanised steel
Free of copper, PTFE and silicone



MUP-40

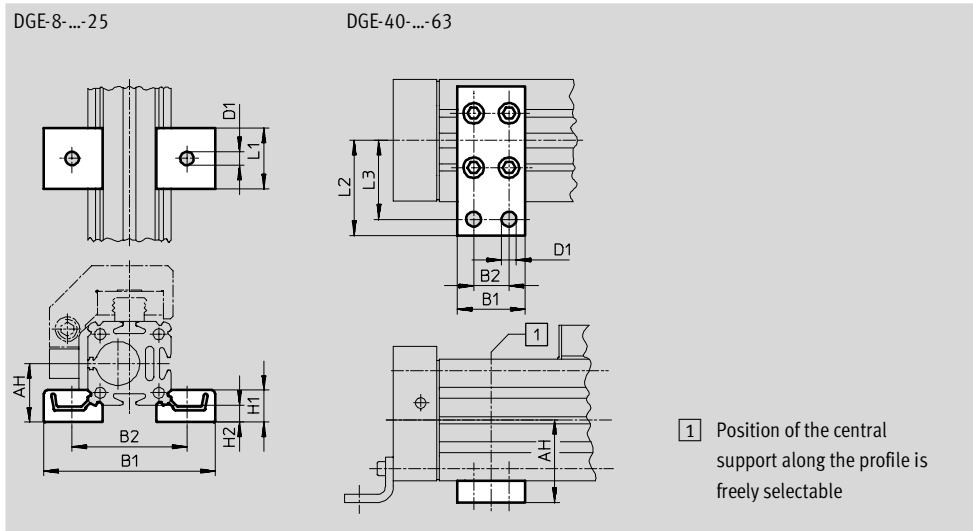

1 Position of the central support along the profile is freely selectable

Dimensions and ordering data												
for size	AH	B1	B2	D1 Ø	H1	H2	L1	L2	L3	Weight [g]	Part No.	Type
18	24	70.5	47	5.5	13	7	25	-	-	33	150 736	MUP-18/25
25	29.5	81	58	5.5	13	7	25	-	-	33	150 736	MUP-18/25
40	46	35	22	6.6	-	-	-	47	40	126	150 738	MUP-40
63	69	50	26	11	-	-	-	77	65	340	150 800	MUP-63

Core Range

Spindle axes DGE

Accessories



Foot mounting HHP

for heavy-duty guide

(order code F)

Material:

Galvanised steel



Central support MUP

for heavy-duty guide

(order code M)

Material:

Galvanised steel

Free of copper, PTFE and silicone



DGE-...-HD18/-HD25/-HD40

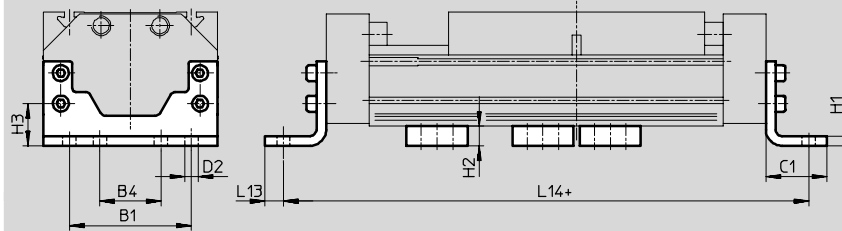
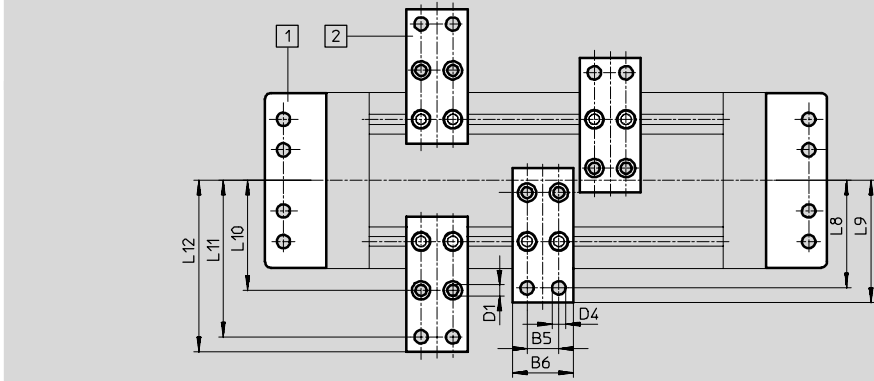

- 1 Foot mounting HHP
- 2 Central support MUP

+ = plus stroke length

Dimensions and ordering data

for heavy-duty guide	B1	B4	B5	B6	C1	D1	D2	D4	H1	H2	H3
HD18	80	40	22	35	34	5.5	6.6	6.6	8	14	26.8
HD25	100	50	26	50	50	9	11	11	8	16	34.5
HD40	140	70	26	50	50	9	11	11	10	16	37

for heavy-duty guide	L8	L9	L10	L11	L12	L13	L14	Weight [g]	Part No.	Type
HD18	68	75	64	92	99	9	290	357	161 993	HHP-18
								126	150 738	MUP-40
HD25	88	100	90	128	140	15	380	794	161 994	HHP-25
								347	150 739	MUP-50
HD40	108	120	110	148	160	15	424	1318	161 995	HHP-40
								347	150 739	MUP-50

Core Range

Spindle axes DGE

Accessories



Shock absorber YSR-...-C

(order code C)

Material:

Housing: galvanised steel; piston rod:
high-alloy steel,
seals: nitrile rubber, polyurethane
Free of copper, PTFE and silicone



Note

Shock absorber YSRW with progressive characteristics
➔ Volume 1

Ordering data		Part No.	Type
for size	Weight [g]		
18	30	34 571	YSR-8-8-C
25	70	34 572	YSR-12-12-C
40	140	34 573	YSR-16-20-C
63	240	34 574	YSR-20-25-C

Shock absorber retainer KYP

(order code C)

Material:

Retainer: Aluminium
Sleeve: Corrosion resistant steel



1 Shock absorber retainer KYP
(if the retainer is in contact with the end cap, i.e. cap serves to secure position, the entire stroke length can be utilised)

2 Shock absorber YSR-...-C

3 Position retainer
(included in scope of delivery either behind or underneath the shock absorber retainer KYP)

Dimensions and ordering data								
for size	B8	D1	D5	H2	H4	Weight [g]	Part No.	Type
18	14	M12x1	M4	50.5	4.5	66	158 907	KYP-18
25	19	M16x1	M5	69.5	6	95	158 908	KYP-25
40	32	M22x1.5	M5	102	8	209	158 910	KYP-40
63	44	M26x1.5	M10	152.5	11.5	609	158 912	KYP-63

Core Range

Spindle axes DGE

Accessories



Emergency buffer NPE (order code A)

Material:
Polyurethane

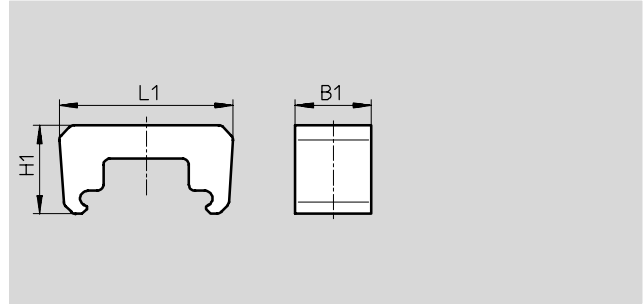
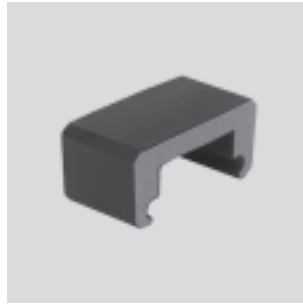

Dimensions and ordering data						
for size	B1	L1	H1	Weight [g]	Part No.	Type
18	15	43.1	28.5	6	193 901	NPE-18
25	25	57	29	12	193 902	NPE-25
40	40	80.5	36	41	193 904	NPE-40
63	60	128.6	55	152	193 906	NPE-63

 Note
The emergency buffer can only be used in conjunction with shock absorber retainer KYP.
→ 5 / 2.1-172
(A threaded pin and nut are not required.)

Shock absorber DG-GA for protected version GA (order code E)

Material:
Housing: galvanised steel; piston rod: high-alloy steel,
seals: nitrile rubber, polyurethane
Free of copper, PTFE and silicone



Ordering data			
for size	Weight [g]	Part No.	Type
25	70	192 875	DG-GA-25-YSR
40	140	192 877	DG-GA-40-YSR

Spindle axes DGE

Accessories



Shock absorber kit YHD

for heavy-duty guide

(order code D)

Material:

Housing: Galvanised steel

Seals: TPE-U(PU) NBR

Free of copper, PTFE and silicone





Ordering data			
for heavy-duty guide	Weight [g]	Part No.	Type
HD18	203	174 544	YHD-18
HD25	293	174 545	YHD-25
HD40	515	174 546	YHD-40

Spindle axes DGE

Accessories

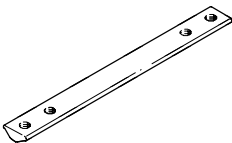

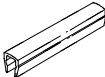
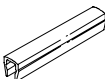
Ordering data					Technical data → Volume 1	
	for size	Remarks	Order code	Part No.	Type	PU ¹⁾
Slot nut NST						
	18, 25	For mounting slot	Y	526 091	NST-HMV-M4	1
	40			150 914	NST-5-M5	1
	63			150 915	NST-8-M6	1
	HD18, HD25	For heavy-duty guide: mounting slot	Y	150 914	NST-5-M5	1
	HD40			150 915	NST-8-M6	1
	HD18	For heavy-duty guide:	U	150 914	NST-5-M5	1
	HD25, HD40	HD underneath		150 915	NST-8-M6	1
Slot nut NSTL						
	25	For slide	X	158 410	NSTL-25	1
	40			158 412	NSTL-40	1
	63			158 414	NSTL-63	1
	HD18	For heavy-duty guide: slide	X	161 020	NSTH-18	1
	HD25			161 021	NSTH-25	1
	HD40			161 022	NSTH-40	1
Centring pin/sleeve ZBS/ZBH						
	18	For slide	Z	150 928	ZBS-5	10
	25 ... 63			150 927	ZBH-9	10
Central mounting SLZZ						
	HD18	For heavy-duty guide: slide	Q	150 901	SLZZ-25/16	1
	HD25					
	HD40					
Slot cover ABP						
	40	For mounting slot each 0.5 m	B	151 681	ABP-5	2
	63			151 682	ABP-8	
	HD18, HD25	For mounting slot at side and underneath, each 0.5 m		151 681	ABP-5	
	HD40			151 682	ABP-8	
Slot cover ABP-S						
	18 ... 63	For sensor slot each 0.5 m	S	151 680	ABP-5-S	2

1) Packaging unit quantity

 Core Range

Spindle axes DGE

Accessories



Sensor bracket HWS

for sensors
(order code T)

Material:
Galvanised steel



DGE-18/25

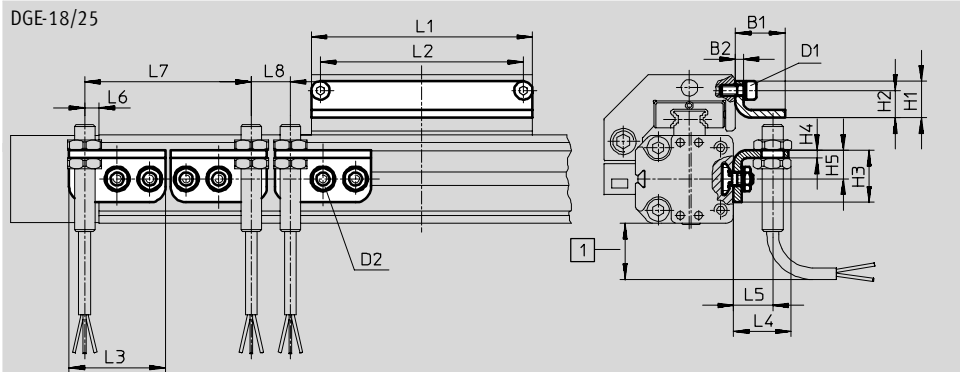

DGE-40/63

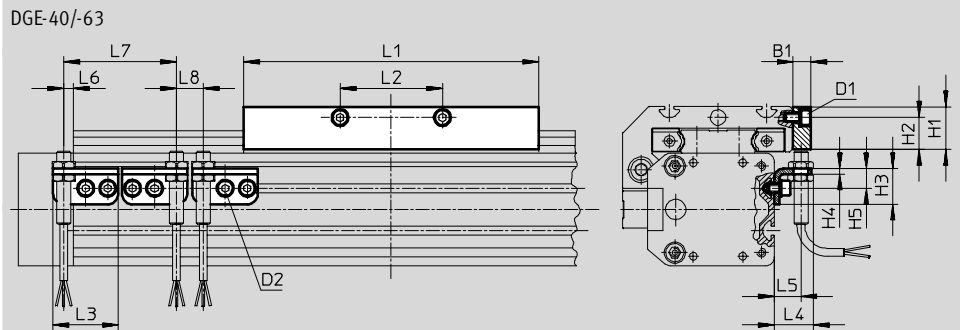

1 Protruding sensor cable, ensure sufficient installation space

Switching lug SF

(order code L)

Material:
Galvanised steel



Dimensions and ordering data

for size	D1	D2	B1	B2	H1	H2	H3	H4	H5	L1	L2	L3	L4	L5
18	M4	M5	19	3	14	10.5	20	3	11	85	78	37	22.5	15
25	M5	M5	15	3	18	12	20	3	11	105	88	37	22.5	15
40	M5	M5	10	-	24	18	20	3	11	167	58	37	22.5	15
63	M8	M5	10	-	35	25	20	3	11	230	72	37	22.5	15

for size	L6 max.	L7 min.	L8 min.	Weight [g]	Part No.	Type
18	5.5	64	15	30	188 968	HWS-18/25-M8
				60	188 964	SF-18
25	5.5	64	15	30	188 968	HWS-18/25-M8
				80	188 965	SF-25
40	5.5	64	15	40	188 969	HWS-40-M8
				310	188 966	SF-40
63	5.5	64	15	40	188 970	HWS-63-M8
				630	188 967	SF-63



Spindle axes DGE



Accessories







FESTO







Electrical positioning systems
Electromechanical drives

2.1

Ordering data – Proximity sensors for slot type 8, magnetic reed						Technical data → Volume 1	
	Mounting	Electrical connection		Cable length [m]	Part No.	Type	
		Cable	Plug M8				
Normally open contact							
	Insertable from end, flush with the cylinder profile	3-wire	–	2.5	150 855	SME-8-K-LED-24	
		–	3-pin	0.3	150 857	SME-8-S-LED-24	
Normally closed contact							
	Insertable from above	3-wire	–	7.5	525 906	SME-8F-DO-24V-K7,5-OE	

Ordering data – Proximity sensors for slot type 8, magneto-resistive						Technical data → Volume 1	
	Mounting	Switch output	Electrical connection		Cable length [m]	Part No.	Type
			Cable	Plug M8			
Normally open contact							
	Insertable from end, flush with the cylinder profile	PNP	3-pin	–	2.5	175 436	SMT-8-PS-K-LED-24-B
			–	3-pin	0.3	175 484	SMT-8-PS-S-LED-24-B
Normally closed contact							
	Insertable from above	PNP	3-wire	–	7.5	525 911	SMT-8F-PO-24V-K7,5-OE 

Ordering data – Inductive proximity sensors M8					Technical data → Volume 4		
	Electrical connection		Switch output	LED	Cable length [m]	Part No.	Type
	Cable	Plug M8					
Normally open contact							
	3-wire	–	PNP		2.5	150 386	SIEN-M8B-PS-K-L
	–	3-pin	PNP			150 387	SIEN-M8B-PS-S-L
Normally closed contact							
	3-wire	–	PNP		2.5	150 390	SIEN-M8B-PO-K-L
	–	3-pin	PNP			150 391	SIEN-M8B-PO-S-L

Ordering data – Plug sockets						Technical data → Volume 1	
	Mounting	Switch output		Connection	Cable length [m]	Part No.	Type
		PNP	NPN				
Straight socket							
	M8 locknut			3-pin	2.5	159 420	SIM-M8-3GD-2,5-PU
					5	159 421	SIM-M8-3GD-5-PU
Angled socket							
	M8 locknut			3-pin	2.5	159 422	SIM-M8-3WD-2,5-PU
					5	159 423	SIM-M8-3WD-5-PU

 Core Range

