



- Resistant to corrosion caused by harsh ambient conditions
- Easy to clean design
- Wide choice of variants
- Comprehensive range of accessories

Specified types in accordance with ATEX directive for potentially explosive atmospheres  
→ [www.festo.com/en/ex](http://www.festo.com/en/ex)

# Corrosion-resistant cylinders

Features

## Cylinder applications

Reliable components need to achieve 100% operational reliability, even in harsh operating conditions. The aim is to maximise availability of machinery while minimising downtimes. Corrosion-resistant cylinders are therefore used in applications where the surface finish of normal pneumatic drives would render them non-resistant to the surrounding media. However designing a corrosion-resistant system involves more than simply selecting a suitable steel – it also requires the selection of a tailored concept for mounting components and accessories.

## Cylinder strengths

Festo's corrosion-resistant cylinders are made from highly resistant materials such as 1.4301 and 1.4401. These popular high-alloy, stainless austenitic chrome/nickel and chrome/nickel/molybdenum steels protect against chemical or electrochemical stress as well as damage to the material surface caused by cleaning or detergents. The indicated groups of materials are particularly resistant to uniform surface corrosion and offer increased protection against pitting and crevice corrosion.

## Cylinder advantages

Festo's worldwide service network ensures optimum availability of corrosion-resistant cylinders. As well as a comprehensive range of standard cylinders to DIN ISO 6431 and 6432, we also offer a range of tailored mounting components and accessories. The corrosion-resistant cylinders are assembled with USDA-H1 lubricating grease and wiper seals in accordance with BGV (Federal Institute for Risk Assessment) guidelines. This means that they are suitable for use in the food industry and for direct contact with food products. We will be pleased to answer any inquiries you may have about future additions to our corrosion-resistant range. Just give us a call.

## Good to know

Our many years of experience in the area of stainless steel can be invaluable when you are investigating solutions for aggressive environment. Our experts can answer any questions you might have about surface finishes and chemical resistance.



The atmosphere in the curing cellar of a cheese factory consists of an unpleasant mix of ammonia, lactic acid and 98% humidity.



An area subject to radiation of up to 4 sievert/h whilst immersed in fully desalinated water in a manipulator for dismantling nuclear reactor pressure reservoirs and thermal shields.

# Corrosion-resistant cylinders

Features

## Resistance

Complete resistance to pitting and crevice corrosion is not always possible, even with ideal application parameters. The following parameters increase the pitting effect of chloride ions:

- Concentration of chloride ions
- Duration of contact
- Temperature
- Increasing ph value

It must therefore be ensured during design, assembly and operation that all parts of the machinery can be properly cleaned to avoid an accumulation of chloride ions.

Selected sealing materials ensure very high resistance to a wide range of chemical compounds. Further information on resistance to media can be obtained on the Internet at [www.festo.com](http://www.festo.com).

In principle, we recommend that the cylinder be cleaned with the piston rod in the retracted position to avoid the risk of washing out the lifetime lubrication.

Various types of machinery contamination make cleaning processes necessary in many industrial sectors. The degree of cleaning required ranges from wiping the machinery to wet cleaning to foam cleaning with different exposure times and concentrations.

It is therefore impossible to make a general recommendation on compatibility.



Wet cleaning





Foam cleaning

# Corrosion-resistant cylinders

Product range overview

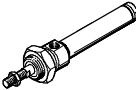
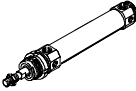

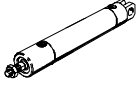
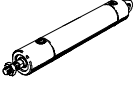
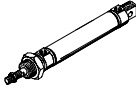
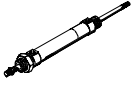
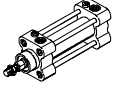
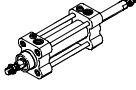
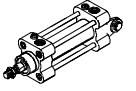
Function	Design	Type	Conforms to	Piston $\varnothing$	Stroke
Double-acting	<b>Round cylinders</b>				
		<b>CRDG</b> Piston rod at one end	–	12, 16 20 25, 32, 40, 50, 63	1 ... 200 1 ... 320 1 ... 500
		<b>CRDSW</b> Piston rod at one end	–	32, 40, 50, 63	1 ... 500
		<b>CRD...MQ</b> Bearing cap with male thread	–	32, 40, 50, 63, 80, 100	10 ... 500 Special lengths on request
		<b>CRD...MC</b> End cap with yoke	–	32, 40, 50, 63, 80, 100	10 ... 500 Special lengths on request
		<b>CRD...MS</b> End cap with lug	–	32, 40, 50, 63, 80, 100	10 ... 500 Special lengths on request
	<b>Standard cylinders</b>				
		<b>CRDSNU</b> Piston rod at one end	ISO 6432	12, 16 20 25	10 ... 200 10 ... 320 10 ... 500
		<b>CRDSNU- ... -S2</b> Through piston rod		12, 16 20 25	10 ... 200 10 ... 320 10 ... 500
		<b>CRDNG</b> Piston rod at one end	ISO 6431 VDMA 24 562	32, 40, 50, 63, 80, 100, 125	10 ... 2000
		<b>CRDNG- ... -S2</b> Through piston rod		32, 40, 50, 63, 80, 100, 125	10 ... 2000
	<b>Standard cylinders with swivel bearing at rear</b>				
		<b>CRDNGS</b> Piston rod at one end	ISO 6431 VDMA 24 562	32, 40, 50, 63, 80, 100, 125	10 ... 2000

Cylinders with piston rods  
Corrosion-resistant cylinders

2.7

# Corrosion-resistant cylinders

Product range overview



Type	Position sensing A	Cushioning		Heat resistant S6	→ Page
		Non-adjustable at both ends	Adjustable at both ends		
		P	PPV		
<b>Round cylinders</b>					
<b>CRDG</b> Piston rod at one end	■	■	-	-	1 / 2.7-6
<b>CRDSW</b> Piston rod at one end	■	■	-	-	1 / 2.7-12
<b>CRHD ... MQ</b> Bearing cap with male thread	■	-	■	■	1 / 2.7-17
<b>CRHD ... MC</b> End cap with yoke	■	-	■	■	1 / 2.7-17
<b>CRHD ... MS</b> End cap with lug	■	-	■	■	1 / 2.7-17
<b>Standard cylinders</b>					
<b>CRDSNU</b> Piston rod at one end	■	■	-	-	1 / 2.7-24
<b>CRDSNU- ... -S2</b> Through piston rod	■	■	-	-	1 / 2.7-24
<b>Standard cylinders with swivel bearing at rear</b>					
<b>CRDNG</b> Piston rod at one end	■	-	■	■	1 / 2.7-30
<b>CRDNG- ... -S2</b> Through piston rod	■	-	■	■	1 / 2.7-30
<b>Standard cylinders with swivel bearing at rear</b>					
<b>CRDNGS</b> Piston rod at one end	■	-	■	■	1 / 2.7-30

# Round cylinders CRDG, corrosion-resistant

Peripherals overview



## CRDG

Piston  $\varnothing$  12 ... 25 mm

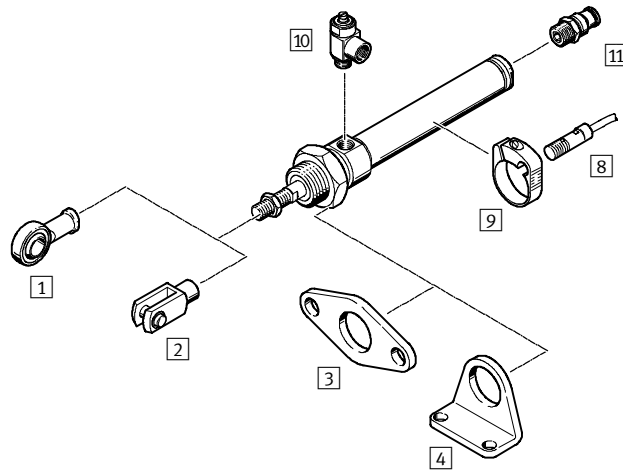

Piston  $\varnothing$  32 ... 63 mm

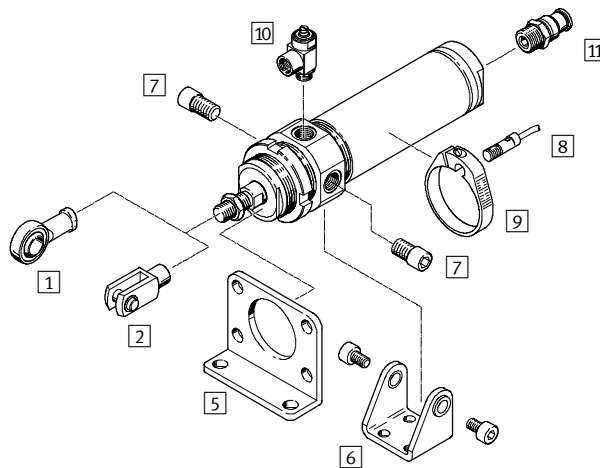

### Mounting options

Piston  $\varnothing$  12 ... 25 mm

Threaded mounting

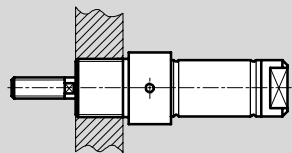

Mounting with hex nut

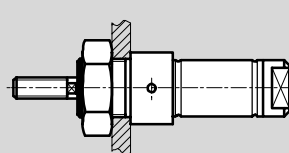

Piston  $\varnothing$  32 ... 63 mm

Threaded mounting

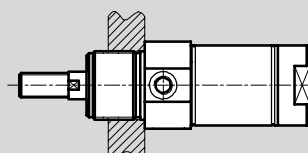

Mounting with slotted nut

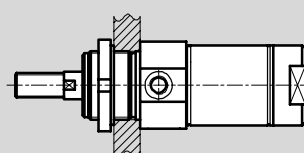

# Round cylinders CRDG, corrosion-resistant

Peripherals overview

FESTO

Mounting attachments and accessories					
	Brief description	Piston $\varnothing$ 12 ... 25 mm	Piston $\varnothing$ 32 ... 63 mm	→ Page	
1	Rod eye CRSGS	With spherical bearing	■	■	1 / 2.8-9
2	Rod clevis CRSG	Permits a swivelling movement of the cylinder in one plane	■	■	1 / 2.8-9
3	Flange mounting CRFBN	For bearing cap	■	-	1 / 2.8-3
4	Foot mounting CRHBN	For bearing cap	■	-	1 / 2.8-1
5	Flange mounting CRFV	For bearing cap	-	■	1 / 2.8-3
6	Clevis foot CRSBS	For bearing cap	-	■	1 / 2.8-7
7	Pivot bolt CRGBS	For bearing cap	-	■	1 / 2.8-7
8	Proximity sensor CRSMEO-4	With LED for operating status indication	■	■	1 / 2.8-9
9	Mounting kit CRSMBR	For proximity sensor CRSMEO-4	■	■	1 / 2.8-9
10	One-way flow control valve CRGRLA	For speed regulation	■	■	1 / 2.8-9
11	Push-in/threaded fitting CRQS	For connecting compressed air tubing with standard O.D. to CETOP RP 54 P	■	■	Volume 3

# Round cylinders CRDG, corrosion-resistant

Type code



CRDG - 50 - 80 - P - A

<b>Type</b>	
Double-acting	
CRDG	Round cylinder

<b>Piston Ø [mm]</b>	
50	

<b>Stroke [mm]</b>	
80	

<b>Cushioning</b>	
P	Non-adjustable at both ends

<b>Sensing</b>	
A	Position sensing



# Round cylinders CRDG, corrosion-resistant

FESTO

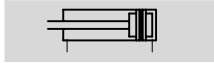

Technical data

Function



[www.festo.com/en/](http://www.festo.com/en/)  
Spare\_parts\_service



-  Diameter  
12 ... 63 mm
-  Stroke length  
1 ... 500 mm

General technical data								
Piston Ø	12	16	20	25	32	40	50	63
Pneumatic connection	M5	M5	G $\frac{1}{8}$	G $\frac{1}{8}$	G $\frac{1}{8}$	G $\frac{1}{4}$	G $\frac{1}{4}$	G $\frac{3}{8}$
Piston rod thread	M6	M6	M8	M10x1.25	M10x1.25	M12x1.25	M16x1.5	M16x1.5
Constructional design	Piston							
	Piston rod							
	Cylinder barrel							
Cushioning	Non-adjustable at both ends							
Position sensing	Via proximity sensor							
Type of mounting	With accessories							
	With male thread							
Mounting position	Any							

Operating and environmental conditions								
Piston Ø	12	16	20	25	32	40	50	63
Operating medium	Filtered compressed air, lubricated or unlubricated							
Operating pressure	1 ... 10 bar							
Ambient temperature <sup>1)</sup> [°C]	-20 ... +80							
Corrosion resistance class CRC <sup>2)</sup>	4							

1) Note operating range of proximity sensors

2) Corrosion resistance class 4 according to Festo standard 940 070

Components requiring higher corrosion resistance. Parts used with aggressive media, e.g. food or chemical industry. These applications should be supported with special tests with the media if required.

Forces [N]								
Piston Ø	12	16	20	25	32	40	50	63
Theoretical force at 6 bar, advancing	68	121	189	295	483	754	1 178	1 870
Theoretical force at 6 bar, retracting	51	104	158	247	415	633	990	1 682

Weights [g]								
Piston Ø	12	16	20	25	32	40	50	63
Product weight at 0 mm stroke	80	120	270	360	560	1 160	1 950	2 964
Additional weight per 10 mm stroke	4	6	8	12	18	22	35	41

# Round cylinders CRDG, corrosion-resistant

Technical data



## Materials

Sectional view

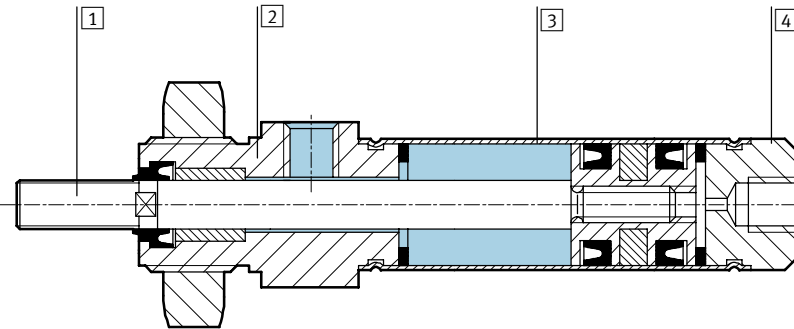

## Cylinder

1	Piston rod	High-alloy stainless steel
2	Bearing cap	High-alloy stainless steel
3	Cylinder barrel	High-alloy stainless steel
4	End cap	High-alloy stainless steel
-	Seals	Polyurethane

## Dimensions

Download CAD data → [www.festo.com/en/engineering](http://www.festo.com/en/engineering)

Piston Ø 12 ... 25mm

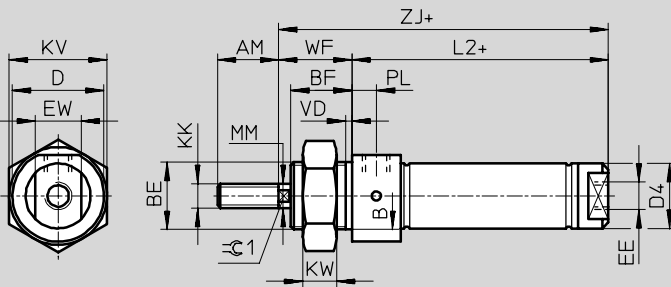

+ plus stroke length

Ø	AM	B	BE	BF	D	D4	EE	EW	KK	KV	KW	MM	L2	PL	VD	WF	ZJ	≈1
[mm]		Ø			Ø	Ø						Ø						
12	16	16	M16x1.5	16	20	13.3	M5	11	M6	24	8	6	44	6	2	22	66	5
16	16	16	M16x1.5	16	20	17.3	M5	15	M6	24	8	6	51	6	2	22	73	5
20	20	22	M22x1.5	19	30	21.3	G½	18	M8	32	11	8	60	8.2	2	24	84	7
25	22	22	M22x1.5	21	30	26.5	G½	21	M10x1.25	32	11	10	61	8.2	2	28	89	9

# Round cylinders CRDG, corrosion-resistant

Technical data



## Dimensions

Download CAD data → [www.festo.com/en/engineering](http://www.festo.com/en/engineering)

Piston Ø 32 ... 63 mm

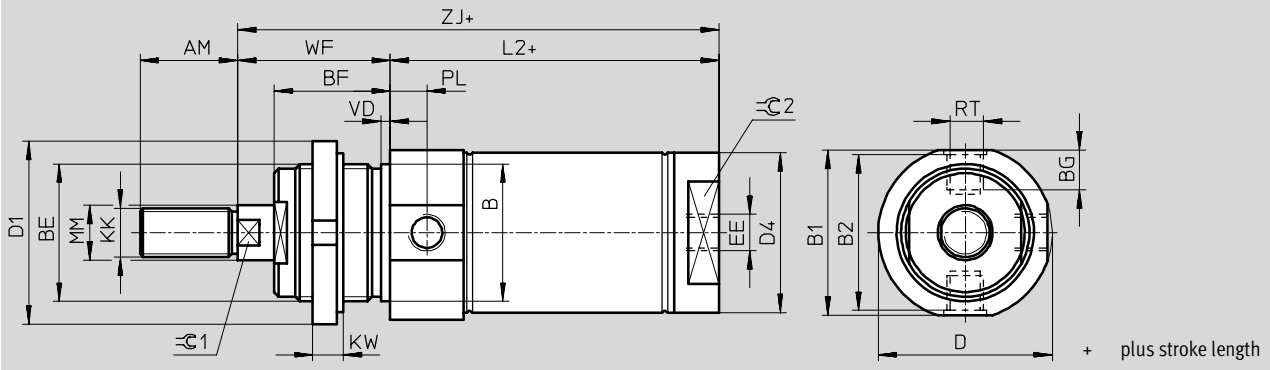

Ø	AM	B	B1	B2	BE	BF	BG	D	D1	D4	EE
[mm]		Ø h9						Ø	Ø	Ø	
32	20	30	38	36.8	M30x1.5	30	6.6	40	42	33.6	G1/8
40	24	38	46	44.8	M38x1.5	35	9.6	49	50	41.6	G1/4
50	32	45	57	55.8	M45x1.5	38	12.6	59	60	52.4	G1/4
63	32	45	70	67	M45x1.5	38	15.5	70	60	65.4	G3/8

Ø	KK	KW	MM	L2	RT	PL	VD	WF	ZJ	C1	C2
[mm]			Ø f8								
32	M10x1.25	8	12	85.7	M8x1	9	2	38.2	123.9	10	27
40	M12x1.25	10	16	100	M10x1	12	3	45.2	145.2	13	36
50	M16x1.5	10	20	107.6	M12x1.5	12	3	50.2	157.8	17	46
63	M16x1.5	10	20	107.8	M14x1.5	13	3	50.2	168	17	55

## Ordering data

	Piston Ø [mm]	Stroke [mm]	Part No.	Type
	12	1 ... 200	<b>160 980</b>	CRDG-12-...-P-A
	16		<b>160 981</b>	CRDG-16-...-P-A
	20	1 ... 320	<b>160 982</b>	CRDG-20-...-P-A
	25	1 ... 500	<b>160 983</b>	CRDG-25-...-P-A
	32		<b>160 984</b>	CRDG-32-...-P-A
	40		<b>160 985</b>	CRDG-40-...-P-A
	50		<b>160 986</b>	CRDG-50-...-P-A
	63		<b>160 987</b>	CRDG-63-...-P-A

# Round cylinders CRDSW, corrosion-resistant

Peripherals overview

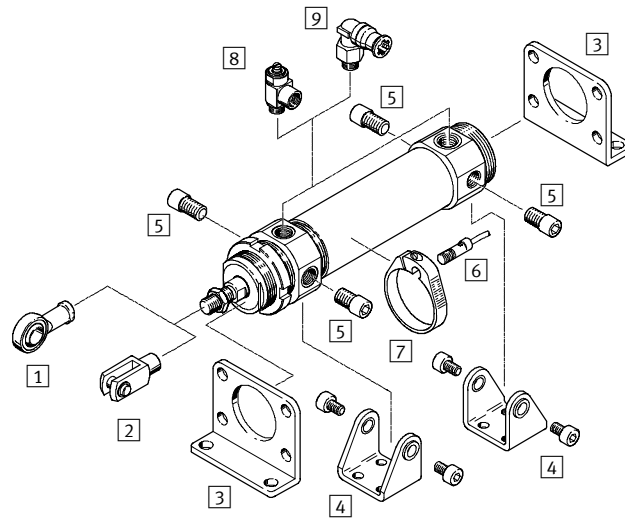

## Mounting options

Threaded mounting

Mounting with slotted nut

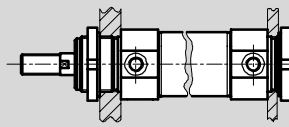
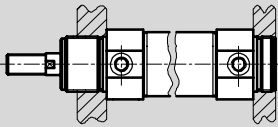

## Mounting attachments and accessories

	Brief description	→ Page
1 Rod eye CRSGS	With spherical bearing	1 / 2.8-9
2 Rod clevis CRSG	Permits a swivelling movement of the cylinder in one plane	1 / 2.8-9
3 Foot mounting CRH (2 pieces)	For bearing and end cap	1 / 2.8-1
3 Flange mounting CRFV	For bearing and end cap	1 / 2.8-3
4 Clevis foot CRSBS	For bearing and end cap	1 / 2.8-7
5 Pivot bolt CRGBS	For bearing and end cap	1 / 2.8-7
6 Proximity sensor CRSMEO-4	With LED for operating status indication	1 / 2.8-9
7 Mounting kit CRSMBR	For proximity sensor CRSMEO-4	1 / 2.8-9
8 One-way flow control valve CRGRLA	For speed regulation	1 / 2.8-9
9 Push-in/threaded fitting CRQS	For connecting compressed air tubing with standard O.D. to CETOP RP 54 P	Volume 3

# Round cylinders CRDSW, corrosion-resistant

Type code

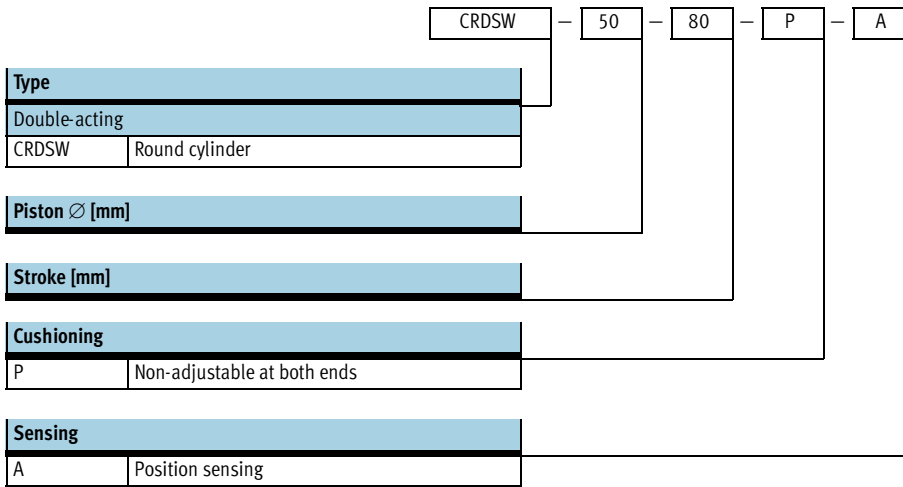

# Round cylinders CRDSW, corrosion-resistant

Technical data



Function

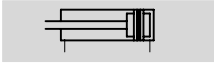

[www.festo.com/en/Spare\\_parts\\_service](http://www.festo.com/en/Spare_parts_service)



- - Diameter  
32 ... 63 mm
- - Stroke length  
1 ... 500 mm

General technical data				
Piston Ø	32	40	50	63
Pneumatic connection	G $\frac{3}{8}$	G $\frac{1}{4}$	G $\frac{1}{4}$	G $\frac{3}{8}$
Piston rod thread	M10x1.25	M12x1.25	M16x1.5	M16x1.5
Constructional design	Piston			
	Piston rod			
	Cylinder barrel			
Cushioning	Non-adjustable at both ends			
Position sensing	Via proximity sensor			
Type of mounting	With accessories			
	With male thread			
Mounting position	Any			

Operating and environmental conditions				
Piston Ø	32	40	50	63
Operating medium	Filtered compressed air, lubricated or unlubricated			
Operating pressure	1 ... 10 bar			
Ambient temperature <sup>1)</sup> [°C]	-20 ... +80			
Corrosion resistance class CRC <sup>2)</sup>	4			

1) Note operating range of proximity sensors

2) Corrosion resistance class 4 according to Festo standard 940 070

Components requiring higher corrosion resistance. Parts used with aggressive media, e.g. food or chemical industry. These applications should be supported with special tests with the media if required.

Forces [N]				
Piston Ø	32	40	50	63
Theoretical force at 6 bar, advancing	483	754	1 178	1 870
Theoretical force at 6 bar, retracting	415	633	990	1 682

Weights [g]				
Piston Ø	32	40	50	63
Product weight at 0 mm stroke	670	1 460	1 960	3 325
Additional weight per 10 mm stroke	18	22	35	41



Pneumatic sizing using Pro Pneu  
[www.festo.com/en/engineering](http://www.festo.com/en/engineering)

# Round cylinders CRDSW, corrosion-resistant

Technical data

FESTO

## Materials

Sectional view

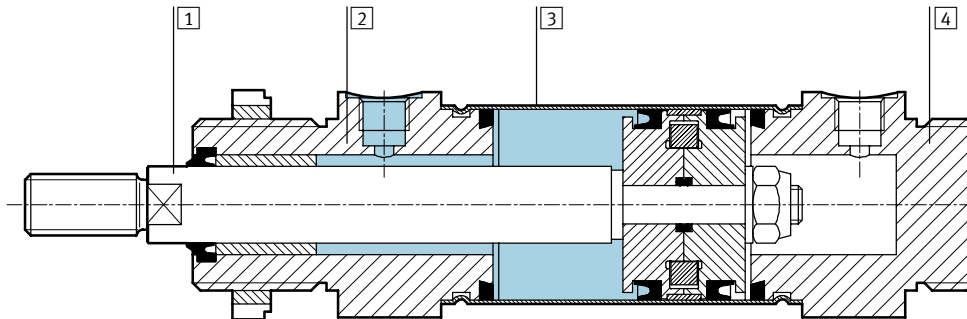

Cylinder		
1	Piston rod	High-alloy stainless steel
2	Bearing cap	High-alloy stainless steel
3	Cylinder barrel	High-alloy stainless steel
4	End cap	High-alloy stainless steel
-	Seals	Polyurethane

# Round cylinders CRDSW, corrosion-resistant

Technical data

**FESTO**

## Dimensions

Download CAD data → [www.festo.com/en/engineering](http://www.festo.com/en/engineering)

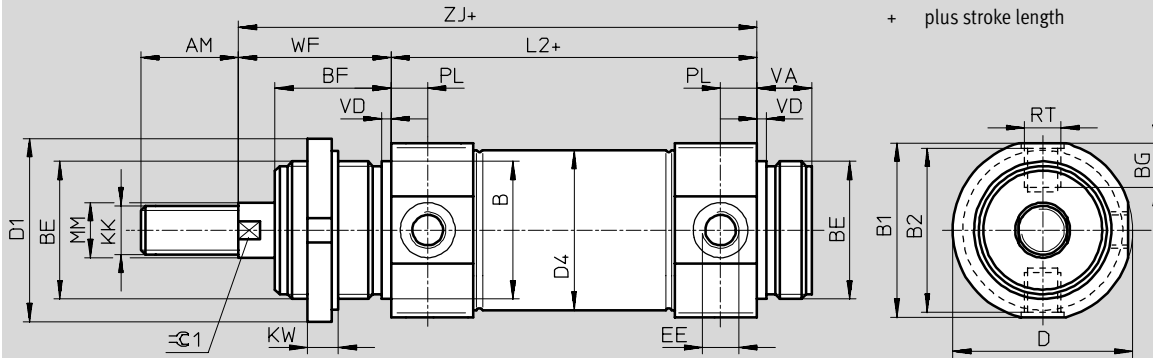

∅	AM	B	B1	B2	BE	BF	BG	D	D1	D4	EE
[mm]		∅ h9						∅	∅	∅	
32	20	30	38	36.8	M30x1.5	30	6.6	40	42	33.6	G1/8
40	24	38	46	44.8	M38x1.5	35	9.6	49	50	41.6	G1/4
50	32	45	57	55.8	M45x1.5	38	12.6	59	60	52.4	G1/4
63	32	45	70	67	M45x1.5	38	15.5	70	60	65.4	G3/8

∅	KK	KW	MM	L2	RT	PL	VA	VD	WF	ZJ	≈C1
[mm]			∅ f8								
32	M10x1.25	8	12	96	M8x1	9	14	2	38.2	134	10
40	M12x1.25	10	16	113	M10x1	12	16	3	45.2	158	13
50	M16x1.5	10	20	120	M12x1.5	12	18	3	50.2	170	17
63	M16x1.5	10	20	124	M14x1.5	13	18	3	50.2	174	17

## Ordering data

	Piston ∅ [mm]	Stroke [mm]	Part No.	Type
	32	1 ... 500	<b>160 676</b>	CRDSW-32-...-P-A
	40		<b>160 677</b>	CRDSW-40-...-P-A
	50		<b>160 678</b>	CRDSW-50-...-P-A
	63		<b>160 679</b>	CRDSW-63-...-P-A

Cylinders with piston rods  
Corrosion-resistant cylinders

2.7



# Round cylinders CRHD, corrosion-resistant

Peripherals overview

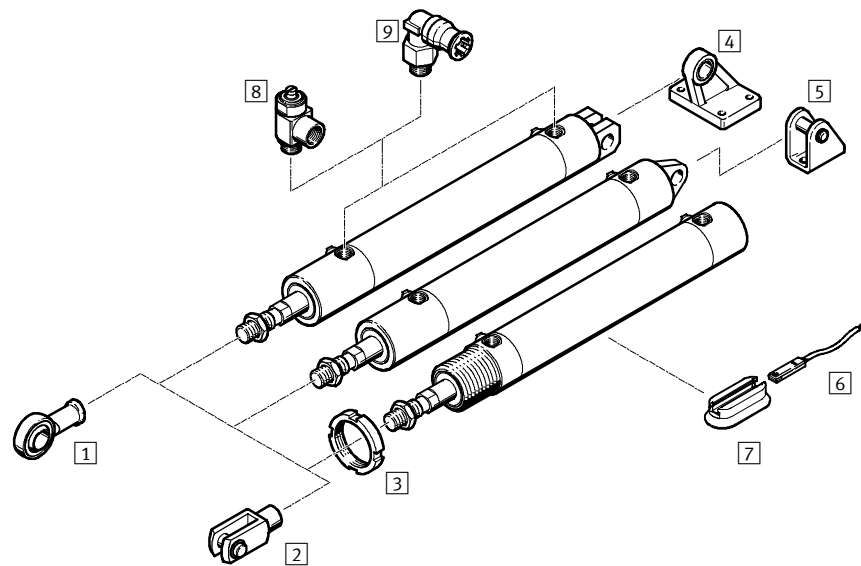

Mounting attachments and accessories						
	Brief description	CRHD-MQ	CRHD-MC	CRHD-MS	→ Page	
1	Rod eye CRSGS	With spherical bearing	■	■	■	1 / 2.8-9
2	Rod clevis CRSG	Permits a swivelling movement of the cylinder in one plane	■	■	■	1 / 2.8-9
3	Ring nut CR	For bearing cap	■	-	-	1 / 2.8-8
4	Clevis foot CRLMC	For end cap	-	■	-	1 / 2.8-8
5	Clevis foot CRLBN	For end cap	-	-	■ Ø 32 ... 63	1 / 2.8-6
6	Proximity sensor CRSMT	With LED for operating status indication	■	■	■	1 / 2.8-9
7	Mounting kit CRSMB-8-32/100	For proximity sensor CRSMT	■	■	■	1 / 2.8-9
8	One-way flow control valve CRGRLA	For speed regulation	■	■	■	1 / 2.8-9
9	Push-in/threaded fittings CRQS	For connecting compressed air tubing with standard O.D. to CETOP RP 54 P	■	■	■	Volume 3

# Round cylinders CRHD, corrosion-resistant

Type code

CRHD – 50 – 80 – PPV – A – MQ – S6

Type	
Double-acting	
CRHD	Round cylinder

Piston $\varnothing$ [mm]	
50	

Stroke [mm]	
80	

Cushioning	
PPV	Adjustable at both ends

Sensing	
A	Position sensing

Cover variant	
MQ	Bearing cap with male thread
MC	End cap with yoke
MS	End cap with lug

Variant	
S6	Heat resistant up to 150 °C

# Round cylinders CRHD, corrosion-resistant

Technical data

Function

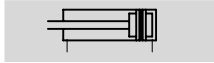

- Diameter  
32 ... 100 mm
- Stroke length  
10 ... 500 mm
- [www.festo.com/en/Spare\\_parts\\_service](http://www.festo.com/en/Spare_parts_service)

Variants



S6

The variant S6 is not suitable for direct contact with food products because of the seals and the grease used.



General technical data						
Piston Ø	32	40	50	63	80	100
Pneumatic connection	G $\frac{1}{8}$	G $\frac{1}{8}$	G $\frac{1}{4}$	G $\frac{3}{8}$	G $\frac{3}{8}$	G $\frac{3}{8}$
Piston rod thread	M10x1.25	M12x1.25	M16x1.5	M16x1.5	M20x1.5	M20x1.5
Constructional design	Piston					
	Piston rod					
	Cylinder barrel					
Cushioning	Adjustable at both ends					
Cushioning length	17	19.5	21	21	31	31
Position sensing	Via proximity sensor					
Type of mounting	With accessories					
Mounting position	Any					

Operating and environmental conditions	
Variant	CRHD S6
Operating medium	Filtered compressed air, lubricated or unlubricated
Operating pressure	1 ... 10 bar
Ambient temperature <sup>1)</sup> [°C]	-20 ... +80 -20 ... +150
Corrosion resistance class CRC <sup>2)</sup>	4

1) Note operating range of proximity sensors

2) Corrosion resistance class 4 according to Festo standard 940 070

Components requiring higher corrosion resistance. Parts used with aggressive media, e.g. food or chemical industry. These applications should be supported with special tests with the media if required.

Forces [N]						
Piston Ø	32	40	50	63	80	100
Theoretical force at 6 bar, advancing	483	754	1 178	1 870	3 016	4 712
Theoretical force at 6 bar, retracting	415	633	990	1 682	2 721	4 418

Weights [g]						
Piston Ø	32	40	50	63	80	100
Product weight at 10 mm stroke	676	1 196	1 849	2 977	5 172	8 472
Additional weight per 10 mm stroke	26	42	57	65	100	115
Moving load at 10 mm stroke	106	198	340	398	717	968
Additional load per 10 mm stroke	9	16	25	25	38	38

# Round cylinders CRHD, corrosion-resistant

Technical data



## Permissible lateral force $F_q$ as a function of stroke length $l$

Horizontal mounting

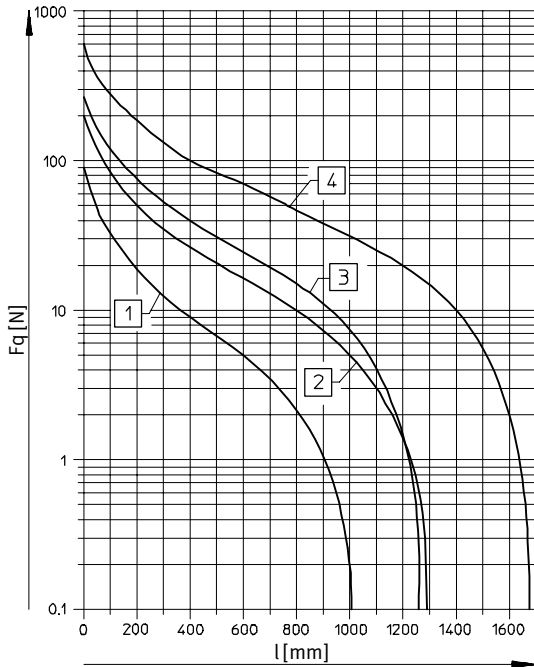

Vertical mounting

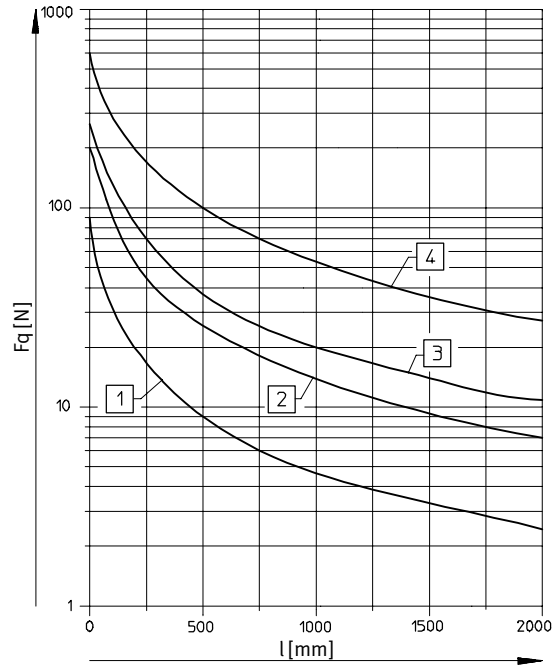

- 1 Ø 32
- 2 Ø 40
- 3 Ø 50, 63
- 4 Ø 80, 100

## Materials

Sectional view

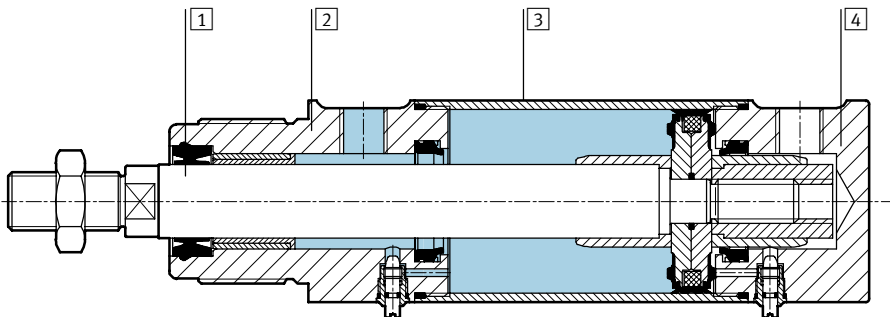

Cylinder	CRHD	S6
1 Piston rod	High-alloy stainless steel	
2 Bearing cap	High-alloy stainless steel	
3 Cylinder barrel	High-alloy stainless steel	
4 End cap	High-alloy stainless steel	
- Seals	Polyurethane, nitrile rubber	Fluorocarbon rubber

# Round cylinders CRHD, corrosion-resistant

Technical data



## Dimensions – CRHD- ... -MQ

Download CAD data → [www.festo.com/en/engineering](http://www.festo.com/en/engineering)

Bearing cap with male thread

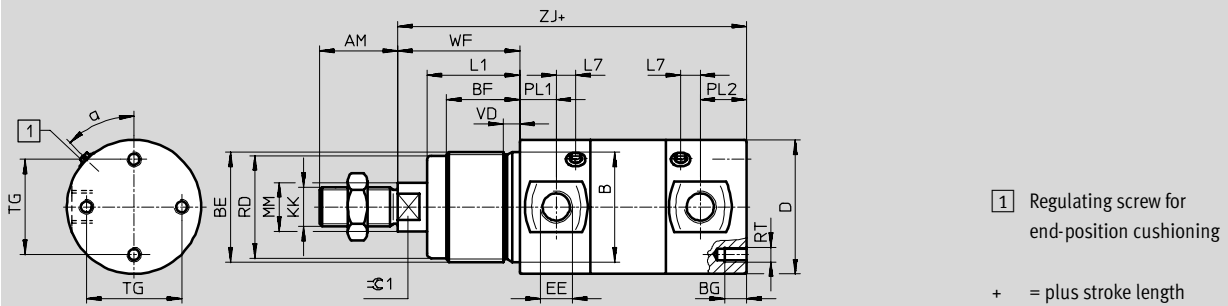

∅	α	AM	B ∅ h9	BE	BF	BG	D ∅	EE	KK	L1
32	50°	22	30	M30x1.5	25	8	36	G $\frac{1}{8}$	M10x1.25	30
40	45°	24	38	M38x1.5	29	8	45	G $\frac{1}{8}$	M12x1.25	35
50	45°	32	45	M45x1.5	30	8	55	G $\frac{1}{4}$	M16x1.5	38
63	45°	32	45	M45x1.5	30	10	68	G $\frac{3}{8}$	M16x1.5	38
80	45°	40	50	M50x2	30	15	86	G $\frac{3}{8}$	M20x1.5	38
100	45°	40	50	M50x2	30	15	106	G $\frac{3}{8}$	M20x1.5	38

∅	L7	MM ∅	RD ∅	RT	PL1	PL2	TG	VD	WF	ZJ	≈C1
32	5	12	27	M5	13	21	22	7	38	120	10
40	8	16	35	M6	15	18	30	7	45	135	13
50	5	20	42	M6	15	19	39	6.25	50	143	17
63	8	20	42	M8	17	24	49	6.25	50	158	17
80	9	25	47	M10	18	31	65	7.5	50	174	22
100	13	25	47	M10	22	30	82	7.5	50	189	22

# Round cylinders CRHD, corrosion-resistant

Technical data



## Dimensions – CRHD- ... -MC

Download CAD data → [www.festo.com/en/engineering](http://www.festo.com/en/engineering)

End cap with yoke

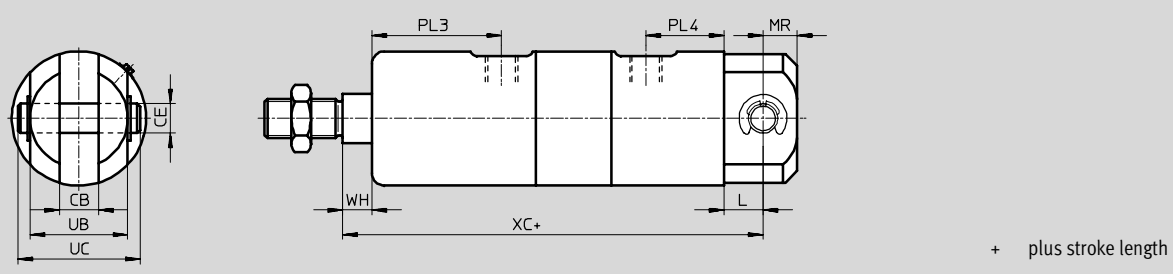

## Dimensions – CRHD- ... -MS

Download CAD data → [www.festo.com/en/engineering](http://www.festo.com/en/engineering)

End cap with lug

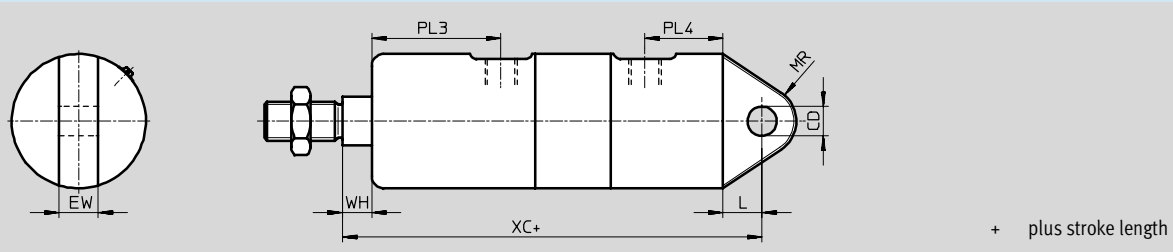







∅	CB	CD	CE	EW	L	MR	PL3	PL4	UB	UC	WH	XC
[mm]	+0.2/+0.1	H9	e8	-0.1/-0.2					-0.1/-0.2			
32	10	10	10	10	15	12	43	28	26	35	8	142
40	12	12	12	12	16	14	40	27	32	43	10	160
50	16	12	12	16	16	14	53	30	40	51	12	170
63	16	16	16	16	22	18	55	34	40	53	12	190
80	20	16	16	20	22	20	56	45	60	73	12	210
100	20	20	20	20	27	25	60	43.5	60	73	12	230

Cylinders with piston rods  
Corrosion-resistant cylinders  
2.7

# Round cylinders CRHD, corrosion-resistant

Technical data

Ordering data				
Type	Piston Ø [mm]	Stroke [mm]	Part No.	Type
<b>MQ – Bearing cap with male thread</b>				
	32	10 ... 500	195 507	CRHD-32-...-PPV-A-MQ
	40		195 508	CRHD-40-...-PPV-A-MQ
	50		195 509	CRHD-50-...-PPV-A-MQ
	63		195 510	CRHD-63-...-PPV-A-MQ
	80		195 511	CRHD-80-...-PPV-A-MQ
	100		195 512	CRHD-100-...-PPV-A-MQ
<b>S6 – Heat resistant up to 150 °C</b>				
	32	10 ... 500	195 543	CRHD-32-...-PPV-A-MQ-S6
	40		195 544	CRHD-40-...-PPV-A-MQ-S6
	50		195 545	CRHD-50-...-PPV-A-MQ-S6
	63		195 546	CRHD-63-...-PPV-A-MQ-S6
	80		195 547	CRHD-80-...-PPV-A-MQ-S6
	100		195 548	CRHD-100-...-PPV-A-MQ-S6
<b>MC – End cap with yoke (pivot pin and lock included in the scope of delivery)</b>				
	32	10 ... 500	195 513	CRHD-32-...-PPV-A-MC
	40		195 514	CRHD-40-...-PPV-A-MC
	50		195 515	CRHD-50-...-PPV-A-MC
	63		195 516	CRHD-63-...-PPV-A-MC
	80		195 517	CRHD-80-...-PPV-A-MC
	100		195 518	CRHD-100-...-PPV-A-MC
<b>S6 – Heat resistant up to 150 °C</b>				
	32	10 ... 500	195 549	CRHD-32-...-PPV-A-MC-S6
	40		195 550	CRHD-40-...-PPV-A-MC-S6
	50		195 551	CRHD-50-...-PPV-A-MC-S6
	63		195 552	CRHD-63-...-PPV-A-MC-S6
	80		195 553	CRHD-80-...-PPV-A-MC-S6
	100		195 554	CRHD-100-...-PPV-A-MC-S6
<b>MS – End cap with lug</b>				
	32	10 ... 500	195 519	CRHD-32-...-PPV-A-MS
	40		195 520	CRHD-40-...-PPV-A-MS
	50		195 521	CRHD-50-...-PPV-A-MS
	63		195 522	CRHD-63-...-PPV-A-MS
	80		195 523	CRHD-80-...-PPV-A-MS
	100		195 524	CRHD-100-...-PPV-A-MS
<b>S6 – Heat resistant up to 150 °C</b>				
	32	10 ... 500	195 555	CRHD-32-...-PPV-A-MS-S6
	40		195 556	CRHD-40-...-PPV-A-MS-S6
	50		195 557	CRHD-50-...-PPV-A-MS-S6
	63		195 558	CRHD-63-...-PPV-A-MS-S6
	80		195 559	CRHD-80-...-PPV-A-MS-S6
	100		195 560	CRHD-100-...-PPV-A-MS-S6

# Standard cylinders CRDSNU to ISO 6432, corrosion-resistant

Peripherals overview

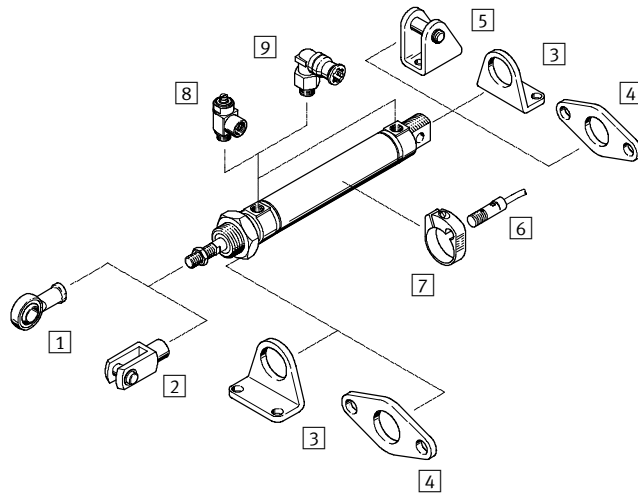

## Variant

CRDSNU-S2

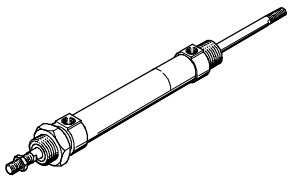

## Mounting options

Threaded mounting

Mounting with hex nut

Swivel mounting at the rear

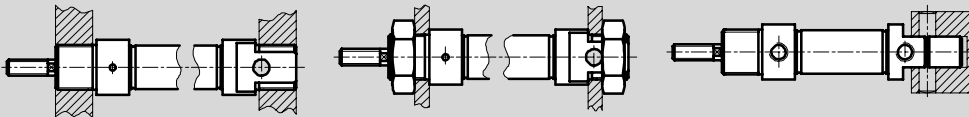

## Mounting attachments and accessories

	Brief description	→Page
1 Rod eye CRSGS	With spherical bearing	1 / 2.8-9
2 Rod clevis CRSG	Permits a swivelling movement of the cylinder in one plane	1 / 2.8-9
3 Foot mounting CRHBN	For bearing and end cap	1 / 2.8-1
4 Flange mounting CRFBN	For bearing or end cap	1 / 2.8-3
5 Clevis foot CRLBN	For direct mounting on end cap	1 / 2.8-6
6 Proximity sensor CRSMEO-4	With LED for operating status indication	1 / 2.8-9
7 Mounting kit CRSMBR	For proximity sensor CRSMEO-4	1 / 2.8-9
8 One-way flow control valve CRGRLA	For speed regulation	1 / 2.8-9
9 Push-in/threaded fitting CRQS	For connecting compressed air tubing with standard O.D. to CETOP RP 54 P	Volume 3



# Standard cylinders CRDSNU to ISO 6432, corrosion-resistant

Type code

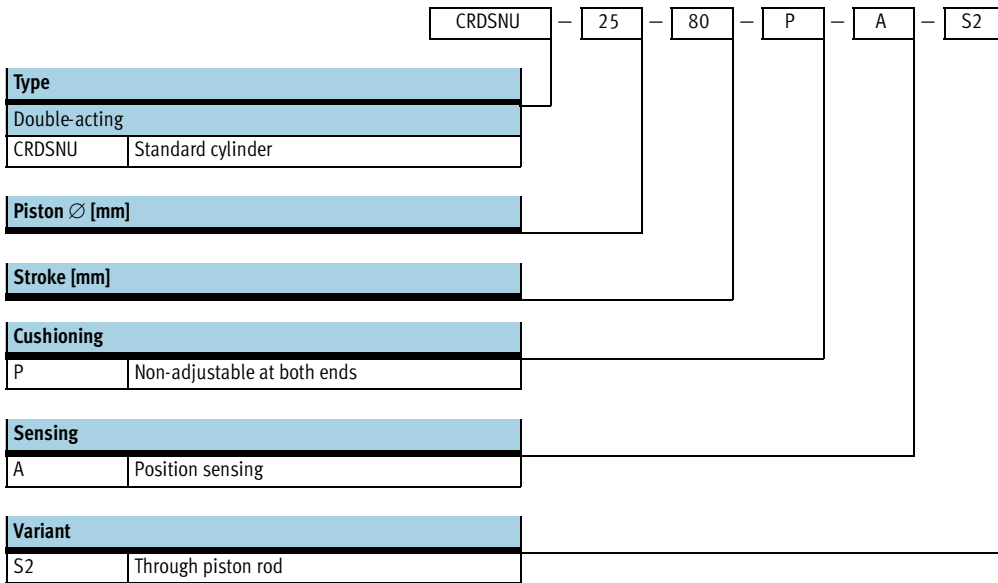

# Standard cylinders CRDSNU to ISO 6432, corrosion-resistant

Technical data



## Function

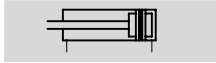

- Diameter  
12 ... 25
- Stroke length  
10 ... 500

## Variants



S2



General technical data				
Piston Ø	12	16	20	25
Pneumatic connection	M5	M5	G1/8	G1/8
Piston rod thread	M6	M6	M8	M10x1.25
Constructional design	Piston			
	Piston rod			
	Cylinder barrel			
Cushioning	Non-adjustable at both ends			
Position sensing	Via proximity sensor			
Type of mounting	With accessories			
	With male thread			
Mounting position	Any			

Operating and environmental conditions				
Piston Ø	12	16	20	25
Operating medium	Filtered compressed air, lubricated or unlubricated			
Operating pressure [bar]	1 ... 10			
Ambient temperature <sup>1)</sup> [°C]	-20 ... +80			
Corrosion resistance class CRC <sup>2)</sup>	4			

1) Note operating range of proximity sensors

2) Corrosion resistance class 4 according to Festo standard 940 070

Components requiring higher corrosion resistance. Parts used with aggressive media, e.g. food or chemical industry. These applications should be supported with special tests with the media if required.

Forces [N] and impact energy [J]				
Piston Ø	12	16	20	25
Theoretical force at 6 bar, advancing	68	121	189	295
Theoretical force at 6 bar, retracting	51	104	158	247
Max. impact energy at end positions	0.07	0.15	0.20	0.30



Pneumatic sizing using Pro Pneu  
[www.festo.com/en/engineering](http://www.festo.com/en/engineering)

# Standard cylinders CRDSNU to ISO 6432, corrosion-resistant

Technical data

Weights [g]				
Piston Ø	12	16	20	25
Product weight at 0 mm stroke	120	150	320	450
Additional weight per 10 mm stroke	4.2	4.8	7.2	10

## Materials

Sectional view

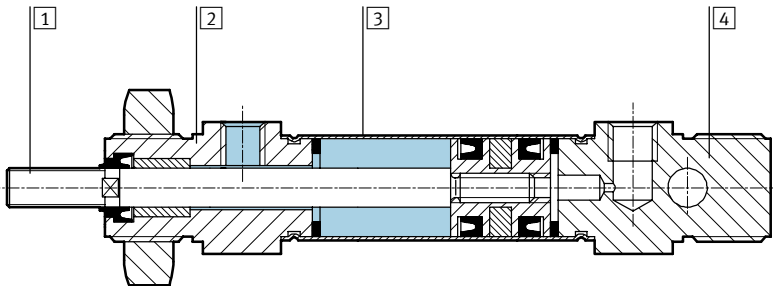

Cylinder	
1	Piston rod High-alloy stainless steel
2	Bearing cap High-alloy stainless steel
3	Cylinder barrel High-alloy stainless steel
4	End cap High-alloy stainless steel
-	Seals Polyurethane

# Standard cylinders CRDSNU to ISO 6432, corrosion-resistant

Technical data



## Dimensions

Download CAD data → [www.festo.com/en/engineering](http://www.festo.com/en/engineering)

### Basic version

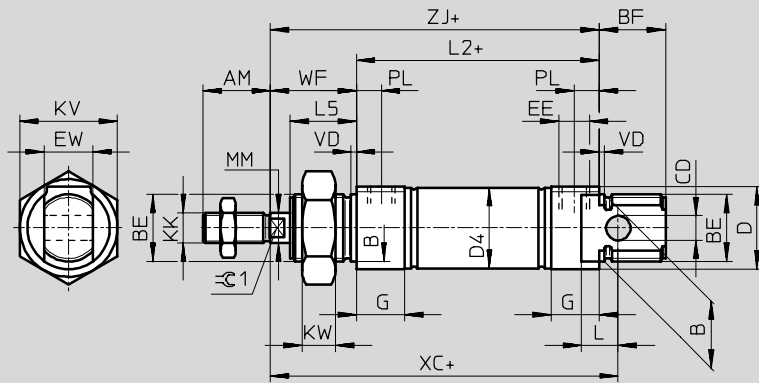

+ plus stroke length

### Variant

#### S2 – Through piston rod

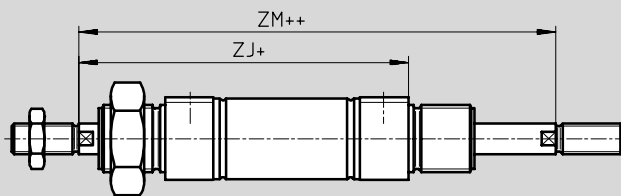

+ plus stroke length  
++ plus 2 stroke lengths



∅	AM	B	BE	BF	CD	D	D4	EE	EW	G	KK	KV
[mm]												
12	16	16	M16x1.5	17	6	20	13.3	M5	12	10	M6	24
16	16	16	M16x1.5	17	6	20	17.3	M5	12	10	M6	24
20	20	22	M22x1.5	20	8	30	21.3	G $\frac{1}{8}$	16	16	M8	32
25	22	22	M22x1.5	22	8	30	26.5	G $\frac{1}{8}$	16	16	M10x1.25	32

∅	KW	MM	L	L2	L5	PL	VD	WF	XC	ZJ	ZM	∅C1
[mm]												
12	8	6	9	50	16	6	2	22	75	72	94	5
16	8	6	9	56	16	6	2	22	82	78	100	5
20	11	8	12	68	19	8.2	2	24	95	92	116	7
25	11	10	12	69.5	21	8.2	2	28	104	97.5	125.4	9

# Standard cylinders CRDSNU to ISO 6432, corrosion-resistant



Technical data

Ordering data				
Variant	Piston Ø [mm]	Stroke [mm]	Part No.	Type
Basic version				
	12	10 ... 200	<b>160 880</b>	CRDSNU-12-...-P-A
	16	10 ... 200	<b>160 881</b>	CRDSNU-16-...-P-A
	20	10 ... 320	<b>160 882</b>	CRDSNU-20-...-P-A
	25	10 ... 500	<b>160 883</b>	CRDSNU-25-...-P-A
S2 – Through piston rod				
	12	10 ... 200	<b>185 289</b>	CRDSNU-12-...-P-A-S2
	16	10 ... 200	<b>185 290</b>	CRDSNU-16-...-P-A-S2
	20	10 ... 320	<b>185 291</b>	CRDSNU-20-...-P-A-S2
	25	10 ... 500	<b>185 292</b>	CRDSNU-25-...-P-A-S2

# Standard cylinders CRDNG to ISO 6431 and VDMA 24 562, corrosion-resistant

Peripherals overview

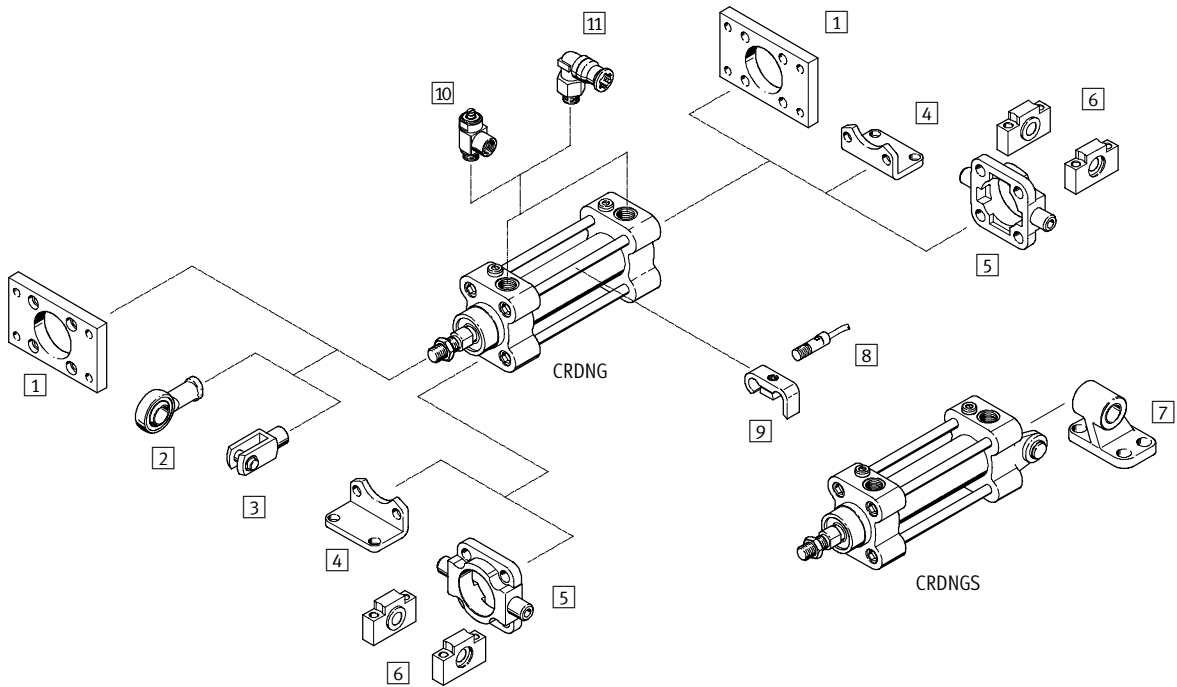

## Variant

CRDNG-S2

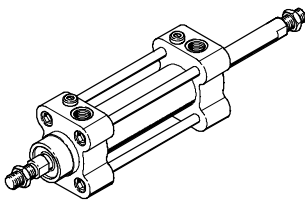

## Mounting options

CRDNG

Mounting at front

Mounting at rear

Mounting from below

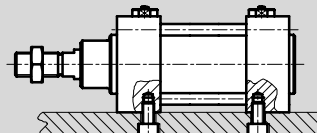
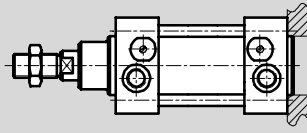
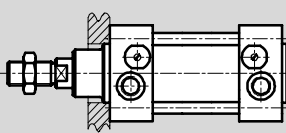

CRDNGS

Mounting at front

Mounting on swivel flange

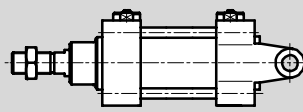
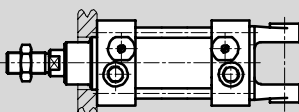

# Standard cylinders CRDNG to ISO 6431 and VDMA 24 562, corrosion-resistant



Peripherals overview

Mounting attachments and accessories					
	Brief description	CRDNG	CRDNGS	→ Page	
1	Flange mounting CRFNG	For bearing or end cap	■	–	1 / 2.8-4
2	Rod eye CRSGS	With spherical bearing	■	■	1 / 2.8-9
3	Rod clevis CRSG	Permits a swivelling movement of the cylinder in one plane	■	■	1 / 2.8-9
4	Foot mounting CRHNC	For bearing and end cap	■	–	1 / 2.8-2
5	Trunnion flange CRZNG	For bearing and end cap in combination with trunnion supports CRLNZG	■	–	1 / 2.8-5
6	Trunnion support CRLNZG	For supporting trunnion flange CRZNG	■	–	1 / 2.8-5
7	Clevis foot CRLNG	For variant with swivel flange	–	■	1 / 2.8-6
8	Proximity sensor CRSMEO-4	With LED for operating status indication	■	■	1 / 2.8-9
9	Mounting kit CRSMB	For proximity sensor CRSMEO-4	■	■	1 / 2.8-9
10	One-way flow control valve CRGRLA	For speed regulation	■	■	1 / 2.8-9
11	Push-in/threaded fittings CRQS	For connecting compressed air tubing with standard O.D. to CETOP RP 54 P	■	■	Volume 3

# Standard cylinders CRDNG to ISO 6431 and VDMA 24 562, corrosion-resistant



Type code

CRDNG – 50 – 80 – PPV – A – S2

**Type**

Double-acting	
CRDNG	Standard cylinder
CRDNGS	Standard cylinder with swivel flange

**Piston Ø [mm]**

**Stroke [mm]**

**Cushioning**

PPV	Adjustable at both ends
-----	-------------------------

**Sensing**

A	Position sensing
---	------------------

**Variant**

S2	Through piston rod
S6	Heat resistant up to 150 °C



# Standard cylinders CRDNG to ISO 6431 and VDMA 24 562, corrosion-resistant

FESTO

Technical data

## Function

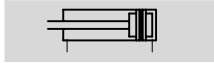

- Diameter  
32 ... 125
- Stroke length  
10 ... 2000
- [www.festo.com/en/Spare\\_parts\\_service](http://www.festo.com/en/Spare_parts_service)

Wearing parts kits  
→ 1 / 2.7-37

## Variants

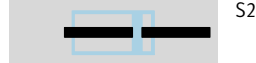

S2



S6

The variant S6 is not suitable for direct contact with food products because of the seals and the grease used.

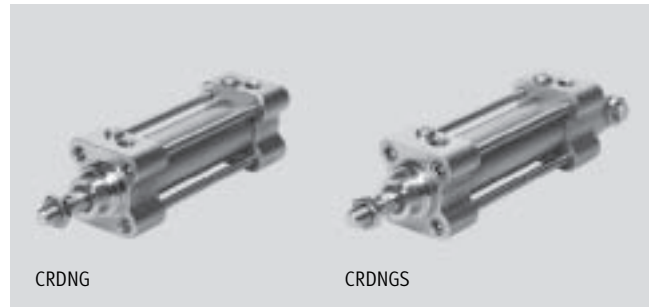

CRDNG

CRDNGS



General technical data							
Piston Ø	32	40	50	63	80	100	125
Pneumatic connection	G $\frac{1}{8}$	G $\frac{1}{4}$	G $\frac{1}{4}$	G $\frac{3}{8}$	G $\frac{3}{8}$	G $\frac{1}{2}$	G $\frac{1}{2}$
Piston rod thread	M10x1.25	M12x1.25	M16x1.5	M16x1.5	M20x1.5	M20x1.5	M27x2
Constructional design	Piston						
	Piston rod						
	Cylinder barrel						
Cushioning	Adjustable at both ends						
Cushioning length [mm]	20	20	23	23	30	30	40
Position sensing	Via proximity sensor						
Type of mounting	With accessories						
	With female thread						
Mounting position	Any						

Operating and environmental conditions	
Variant	CRDNG/CRDNGS   S6
Operating medium	Filtered compressed air, lubricated or unlubricated
Operating pressure	0.6 ... 10 bar
Ambient temperature <sup>1)</sup> [°C]	-20 ... +80   -20 ... +150
Corrosion resistance class CRC <sup>2)</sup>	4

1) Note operating range of proximity sensors

2) Corrosion resistance class 4 according to Festo standard 940 070

Components requiring higher corrosion resistance. Parts used with aggressive media, e.g. food or chemical industry. These applications should be supported with special tests with the media if required.

Forces [N]							
Piston Ø	32	40	50	63	80	100	125
Theoretical force at 6 bar, advancing	482	753	1 178	1 870	3 015	4 712	7 360
Theoretical force at 6 bar, retracting	415	633	990	1 682	2 720	4 418	6 880

# Standard cylinders CRDNG to ISO 6431 and VDMA 24 562, corrosion-resistant



Technical data

Weights [g]							
Piston Ø	32	40	50	63	80	100	125
<b>CRDNG</b>							
Product weight at 0 mm stroke	1 045	1 360	2 160	3 455	5 935	8 070	
Additional weight per 10 mm stroke	20	30	60	60	100	110	
<b>CRDNGS</b>							
Product weight at 0 mm stroke	1 070	1 460	2 330				
Additional weight per 10 mm stroke	20	30	60				

## Materials

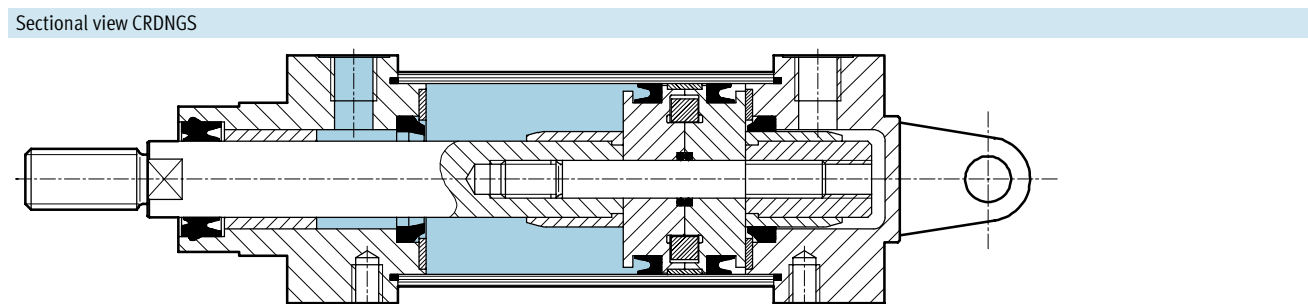
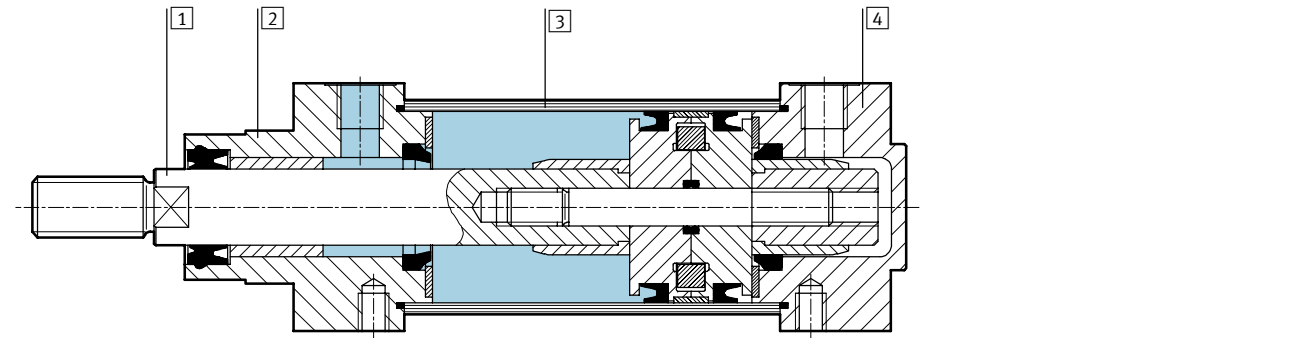

Cylinder	CRDNG/CRDNGS	S6
1 Piston rod	High-alloy stainless steel	
2 Bearing cap	Stainless steel casting	
3 Cylinder barrel	High-alloy stainless steel	
4 End cap	Stainless steel casting	
- Tie rod	High-alloy stainless steel	
- Seals	Polyurethane, nitrile rubber	Fluorocarbon rubber

Cylinders with piston rods  
Corrosion-resistant cylinders

2.7

# Standard cylinders CRDNG to ISO 6431 and VDMA 24 562, corrosion-resistant



Technical data

**Dimensions** Download CAD data → [www.festo.com/en/engineering](http://www.festo.com/en/engineering)

CRDNG

- 1 Socket head screw with female thread
- 2 Cover for adjustable end-position cushioning
- 3 Threaded hole for direct mounting

+ plus stroke length

**Variant** Download CAD data → [www.festo.com/en/engineering](http://www.festo.com/en/engineering)

S2 – Through piston rod

+ plus stroke length  
++ plus 2 stroke lengths

∅	AM	B	BG	D1	D4	D5	E	EE	J2	J3	KK	L1	L2
[mm]		∅ e11			∅	∅							
32	22	30	16	M6	33.6	6	50	G1/8	7	5.7	M10x1.25	16	94 +0.4
40	24	35	16	M6	41.6	6	55	G1/4	10	6.5	M12x1.25	18	105 +0.4/-0.6
50	32	40	16	M8	52.4	8	65	G1/4	11.5	8.6	M16x1.5	25	106 +0.4/-0.6
63	32	45	16	M10	65.4	8	75	G3/8	14.5	12	M16x1.5	25	121 +0.4/-0.6
80	40	45	23	M10	82.8	10	100	G3/8	15	13	M20x1.5	31	128 +0.4/-0.6
100	40	55	23	M12	102.8	10	120	G1/2	23	14	M20x1.5	36	138 +0.4/-0.6
125	54	60	23	M12	126.6	12	145	G1/2	28.5	8	M27x2	31	160 +0.4/-0.6

∅	L3	L7	MM	PL	RT	T1	TG	VA	VD	WH	ZJ	ZM	≡C1	≡C3
[mm]			∅ f8											
32	13	5.3	12	13	M6	9	32.5	4	5	26	120	148	10	6
40	16.5	2.5	16	14	M6	9	38	4	5	30	135	167	13	6
50	21	4.5	20	14	M8	10	46.5	4	5	37	143	183	17	8
63	22	5	20	18	M8	12	56.5	4	5	37	158	199	17	8
80	22.5	6	25	17	M10	15	72	4	5	46	174	222	22	10
100	22.5	9	25	18	M10	18	89	4	5	51	189	240	22	10
125	23.5	4.5	32	27	M12	18	110	6	6	66	226	292	27	12

# Standard cylinders CRDNG to ISO 6431 and VDMA 24 562, corrosion-resistant



Technical data

## Dimensions

CRDNGS

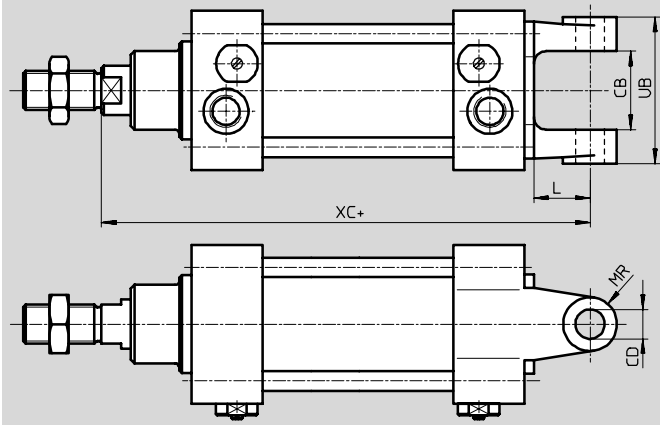





+ plus stroke length

∅	CB	CD	L	MR	UB	XC
[mm]	H14	∅ H9				
32	26	10	18	9	45	142
40	28	12	21	10	52	160
50	32	12	23	11	60	170
63	40	16	28	13	70	190
80	50	16	32	13	90	210
100	60	20	37	17	110	230
125	70	28	44	23	130	276

# Standard cylinders CRDNG to ISO 6431 and VDMA 24 562, corrosion-resistant

FESTO

Technical data

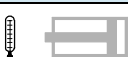
Ordering data				
Variant	Piston Ø [mm]	Stroke [mm]	Part No.	Type
<b>CRDNG</b>				
	32	10 ... 2000	<b>160 884</b>	CRDNG-32-...-PPV-A
	40	10 ... 2000	<b>160 885</b>	CRDNG-40-...-PPV-A
	50	10 ... 2000	<b>160 886</b>	CRDNG-50-...-PPV-A
	63	10 ... 2000	<b>160 887</b>	CRDNG-63-...-PPV-A
	80	10 ... 2000	<b>160 888</b>	CRDNG-80-...-PPV-A
	100	10 ... 2000	<b>160 889</b>	CRDNG-100-...-PPV-A
	125	10 ... 2000	<b>185 280</b>	CRDNG-125-...-PPV-A
<b>S6 – Heat resistant up to 150 °C</b>				
	32	10 ... 2000	<b>185 293</b>	CRDNG-32-...-PPV-A-S6
	40	10 ... 2000	<b>185 294</b>	CRDNG-40-...-PPV-A-S6
	50	10 ... 2000	<b>185 295</b>	CRDNG-50-...-PPV-A-S6
	63	10 ... 2000	<b>185 296</b>	CRDNG-63-...-PPV-A-S6
	80	10 ... 2000	<b>185 297</b>	CRDNG-80-...-PPV-A-S6
	100	10 ... 2000	<b>185 298</b>	CRDNG-100-...-PPV-A-S6
	125	10 ... 2000	<b>185 299</b>	CRDNG-125-...-PPV-A-S6
<b>S2 – Through piston rod</b>				
	32	10 ... 2000	<b>185 282</b>	CRDNG-32-...-PPV-A-S2
	40	10 ... 2000	<b>185 283</b>	CRDNG-40-...-PPV-A-S2
	50	10 ... 2000	<b>185 284</b>	CRDNG-50-...-PPV-A-S2
	63	10 ... 2000	<b>185 285</b>	CRDNG-63-...-PPV-A-S2
	80	10 ... 2000	<b>185 286</b>	CRDNG-80-...-PPV-A-S2
	100	10 ... 2000	<b>185 287</b>	CRDNG-100-...-PPV-A-S2
	125	10 ... 2000	<b>185 288</b>	CRDNG-125-...-PPV-A-S2
<b>CRDNGS</b>				
	32	10 ... 2000	<b>160 890</b>	CRDNGS-32-...-PPV-A
	40	10 ... 2000	<b>160 891</b>	CRDNGS-40-...-PPV-A
	50	10 ... 2000	<b>160 892</b>	CRDNGS-50-...-PPV-A
	63	10 ... 2000	<b>160 893</b>	CRDNGS-63-...-PPV-A
	80	10 ... 2000	<b>160 894</b>	CRDNGS-80-...-PPV-A
	100	10 ... 2000	<b>160 895</b>	CRDNGS-100-...-PPV-A
	125	10 ... 2000	<b>185 281</b>	CRDNGS-125-...-PPV-A
<b>S6 – Heat resistant up to 150 °C</b>				
	32	10 ... 2000	<b>185 300</b>	CRDNGS-32-...-PPV-A-S6
	40	10 ... 2000	<b>185 301</b>	CRDNGS-40-...-PPV-A-S6
	50	10 ... 2000	<b>185 302</b>	CRDNGS-50-...-PPV-A-S6
	63	10 ... 2000	<b>185 303</b>	CRDNGS-63-...-PPV-A-S6
	80	10 ... 2000	<b>185 304</b>	CRDNGS-80-...-PPV-A-S6
	100	10 ... 2000	<b>185 305</b>	CRDNGS-100-...-PPV-A-S6
	125	10 ... 2000	<b>185 306</b>	CRDNGS-125-...-PPV-A-S6

Ordering data – Wearing parts kits					
Piston Ø [mm]	Part No.	Type	Piston Ø [mm]	Part No.	Type
32	<b>125 713</b>	CRDNG/S-32-...-PPV-A <sup>1)</sup>	63	<b>125 716</b>	CRDNG/S-63-...-PPV-A <sup>1)</sup>
40	<b>125 714</b>	CRDNG/S-40-...-PPV-A <sup>1)</sup>	80	<b>125 717</b>	CRDNG/S-80-...-PPV-A <sup>1)</sup>
50	<b>125 715</b>	CRDNG/S-50-...-PPV-A <sup>1)</sup>	100	<b>125 718</b>	CRDNG/S-100-...-PPV-A <sup>1)</sup>

1) Assembly grease included in scope of delivery.



# Accessories for corrosion-resistant cylinders

Technical data

## Foot mounting CRHBN

Scope of delivery:

CRHBN-... x1: 1 foot

CRHBN-... x2: 2 feet, 1 nut

Material:

High-alloy steel

Free of copper, PTFE and silicone



CRHBN-... x2

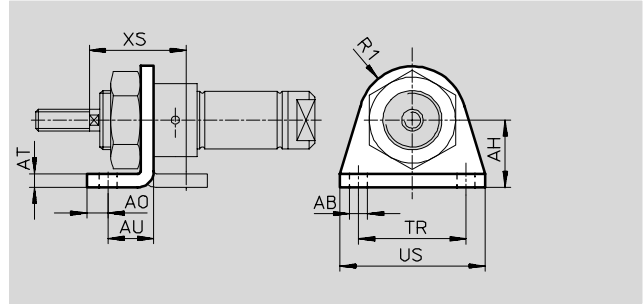

Dimensions and ordering data													
For $\varnothing$	AB	AH	AO	AT	AU	R1	TR	US	XS	CRC <sup>1)</sup>	Weight	Part No.	Type
[mm]	$\varnothing$										[g]		
12	5.5	20	6	2.5	12.5	13	32	42	32	4	40	161 866	CRHBN-12/16x1
16	5.5	20	6	2.5	12.5	13	32	42	32	4	97	162 999	CRHBN-12/16x2
20	6.6	25	8	3	15	20	40	54	36	4	55	161 867	CRHBN-20/25x1
25	6.6	25	8	3	15	20	40	54	40	4	100	162 998	CRHBN-20/25x2

1) Corrosion resistance class 4 according to Festo standard 940 070

Components requiring higher corrosion resistance. Parts used with aggressive media, e.g. food or chemical industry. These applications should be supported with special tests with the media if required.

## Foot mounting CRH

Material:

High-alloy steel

Free of copper, PTFE and silicone

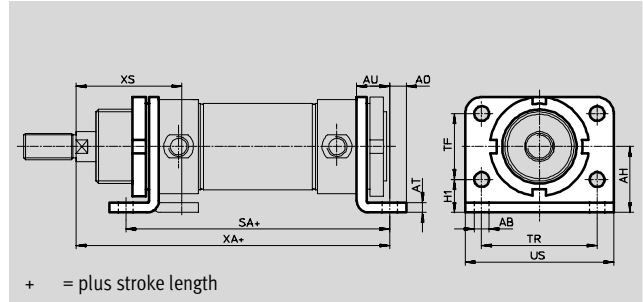

Dimensions and ordering data																
For $\varnothing$	AB	AH	AO	AT	AU	H1	SA	TF	TR	US	XA	XS	CRC <sup>1)</sup>	Weight	Part No.	Type
[mm]	$\varnothing$													[g]		
32	7	28	7	4	14	14	124	28	52	66	148	48	4	237	162 951	CRH-32
40	9	33	10	5	20	18	153	30	60	80	178	60	4	341	162 952	CRH-40
50	9	40	10	6	20	20	160	40	70	90	190	64	4	559	162 953	CRH-50
63	9	45	10	6	20	20	164	50	76	96	195	64	4	680	162 954	CRH-63

1) Corrosion resistance class 4 according to Festo standard 940 070

Components requiring higher corrosion resistance. Parts used with aggressive media, e.g. food or chemical industry. These applications should be supported with special tests with the media if required.

# Accessories for corrosion-resistant cylinders

Technical data



## Foot mounting CRHNC

Material:  
High-alloy steel  
Free of copper, PTFE and silicone

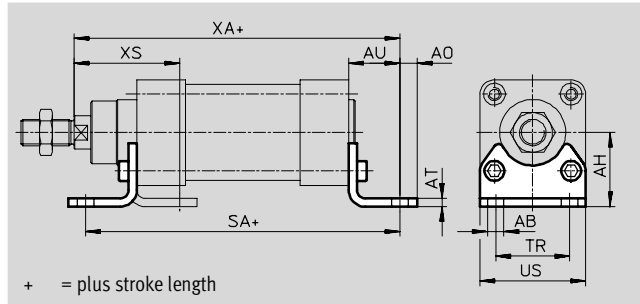

Dimensions and ordering data														
For $\varnothing$	AB $\varnothing$	AH	AO	AT	AU	SA	TR	US	XA	XS	CRC <sup>1)</sup>	Weight [g]	Part No.	Type
[mm]														
32	7	32	6.5	4	24	142	32	45	144.7	45.7	4	135	<b>176 937</b>	<b>CRHNC-32</b>
40	10	36	9	4	28	160.8	36	54	163.6	53.8	4	180	<b>176 938</b>	<b>CRHNC-40</b>
50	10	45	9.5	5	31	167.9	45	64	175	63.1	4	325	<b>176 939</b>	<b>CRHNC-50</b>
63	10	50	12.5	5	32	184.9	50	75	191.5	64.6	4	405	<b>176 940</b>	<b>CRHNC-63</b>
80	12	63	15	6	41	209.9	63	93	215.5	81.6	4	820	<b>176 941</b>	<b>CRHNC-80</b>
100	14.5	71	17.5	6	41	220.1	75	110	229.6	85.5	4	1,000	<b>176 942</b>	<b>CRHNC-100</b>
125	16.5	90	22	8	45	250	90	131	270	102	4	1,840	<b>176 943</b>	<b>CRHNC-125</b>

1) Corrosion resistance class 4 according to Festo standard 940 070  
Components requiring higher corrosion resistance. Parts used with aggressive media, e.g. food or chemical industry. These applications should be supported with special tests with the media if required.



# Accessories for corrosion-resistant cylinders

Technical data

## Flange mounting CRFBN

Material:  
High-alloy steel  
Free of copper, PTFE and silicone

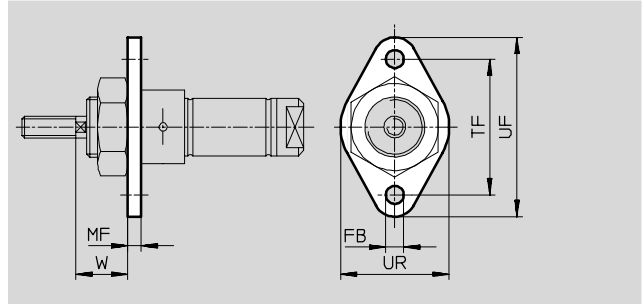

Dimensions and ordering data										
For $\varnothing$	FB	MF	TF	UF	UR	W	CRC <sup>1)</sup>	Weight	Part No.	Type
[mm]	$\varnothing$							[g]		
12, 16	5.5	4	40	53	30	18	4	25	161 864	CRFBN-12/16
20, 25	6.6	5	50	66	40	19	4	45	161 865	CRFBN-20/25

1) Corrosion resistance class 4 according to Festo standard 940 070  
Components requiring higher corrosion resistance. Parts used with aggressive media, e.g. food or chemical industry. These applications should be supported with special tests with the media if required.

## Flange mounting CRFV

Material:  
High-alloy steel  
Free of copper, PTFE and silicone

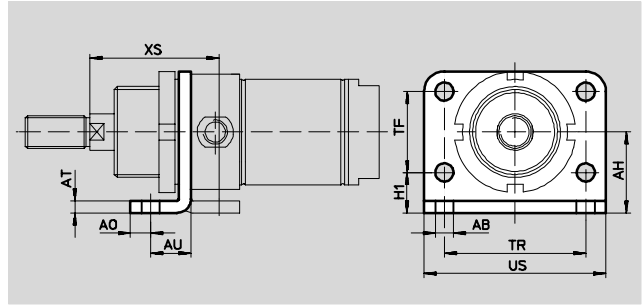

Dimensions and ordering data														
For $\varnothing$	AB	AH	AO	AT	AU	H1	TF	TR	US	XS	CRC <sup>1)</sup>	Weight	Part No.	Type
[mm]	$\varnothing$											[g]		
32	7	28	7	4	14	14	28	52	66	48	4	102	161 858	CRFV-32
40	9	33	10	5	19	18	30	60	80	60	4	190	161 859	CRFV-40
50	9	40	10	6	19	20	40	70	90	64	4	290	161 860	CRFV-50
63	9	45	10	6	19	20	50	76	96	64	4	365	161 861	CRFV-63

1) Corrosion resistance class 4 according to Festo standard 940 070  
Components requiring higher corrosion resistance. Parts used with aggressive media, e.g. food or chemical industry. These applications should be supported with special tests with the media if required.

# Accessories for corrosion-resistant cylinders

Technical data



## Flange mounting CRFNG

Material:  
High-alloy steel  
Free of copper, PTFE and silicone

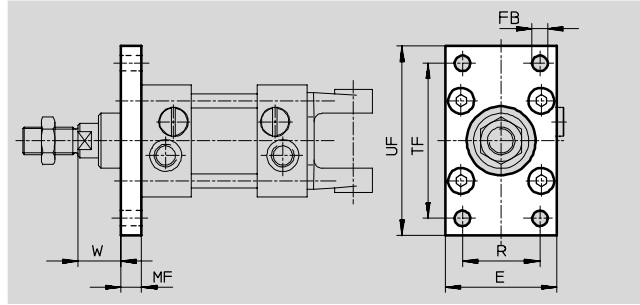
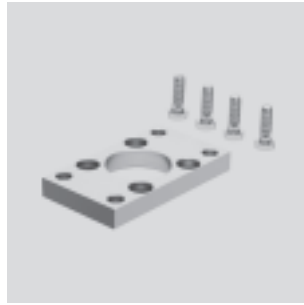

Dimensions and ordering data											
For $\varnothing$	E	FB	MF	R	TF	UF	W	CRC <sup>1)</sup>	Weight	Part No.	Type
[mm]		$\varnothing$							[g]		
32	45	7	10	32	64	80	16	4	240	<b>161 846</b>	<b>CRFNG-32</b>
40	54	9	10	36	72	90	20	4	300	<b>161 847</b>	<b>CRFNG-40</b>
50	65	9	12	45	90	110	25	4	550	<b>161 848</b>	<b>CRFNG-50</b>
63	75	9	12	50	100	120	25	4	710	<b>161 849</b>	<b>CRFNG-63</b>
80	93	12	16	63	126	150	30	4	1,680	<b>161 850</b>	<b>CRFNG-80</b>
100	110	14	16	75	150	175	35	4	2,450	<b>161 851</b>	<b>CRFNG-100</b>
125	132	16	20	90	180	210	45	4	3,660	<b>185 363</b>	<b>CRFNG-125</b>

1) Corrosion resistance class 4 according to Festo standard 940 070  
Components requiring higher corrosion resistance. Parts used with aggressive media, e.g. food or chemical industry. These applications should be supported with special tests with the media if required.

# Accessories for corrosion-resistant cylinders

Technical data

## Trunnion flange CRZNG

Material:  
High-alloy steel  
Free of copper, PTFE and silicone

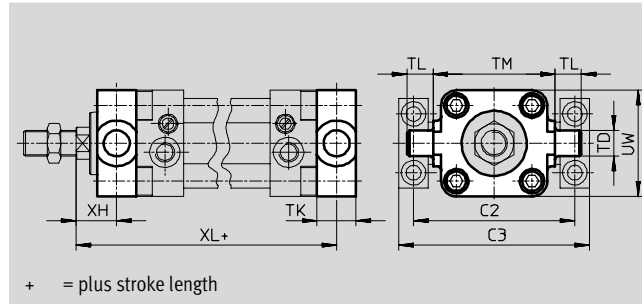

Dimensions and ordering data													
For $\varnothing$	C2	C3	TD $\varnothing$ e9	TK	TL	TM	UW	XH	XL	CRC <sup>1)</sup>	Weight [g]	Part No.	Type
[mm]													
32	71	86	12	16	12	50	50	18	128	4	150	161 852	CRZNG-32
40	87	105	16	20	16	63	55	20	145	4	260	161 853	CRZNG-40
50	99	117	16	24	16	75	65	25	155	4	430	161 854	CRZNG-50
63	116	136	20	24	20	90	75	25	170	4	640	161 855	CRZNG-63
80	136	156	20	28	20	110	100	32	188	4	1,300	161 856	CRZNG-80
100	164	189	25	38	25	132	120	32	208	4	2,400	161 857	CRZNG-100
125	192	217	25	50	25	160	150	40	250	4	3,600	185 362	CRZNG-125

1) Corrosion resistance class 4 according to Festo standard 940 070  
Components requiring higher corrosion resistance. Parts used with aggressive media, e.g. food or chemical industry. These applications should be supported with special tests with the media if required.

## Trunnion support CRLNZG

Material:  
High-alloy steel  
Free of copper, PTFE and silicone

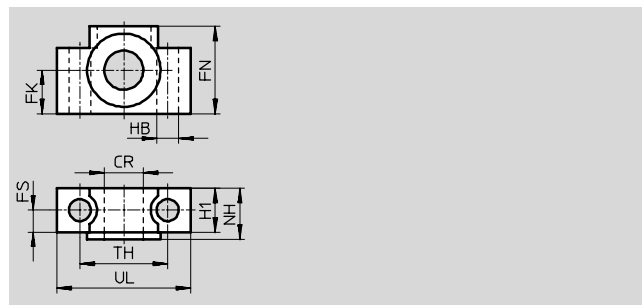
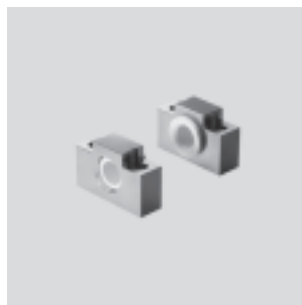

Dimensions and ordering data													
For $\varnothing$	CR	FK $\varnothing$	FN	FS	H1	HB $\varnothing$	NH	TH $\pm 0.2$	UL	CRC <sup>1)</sup>	Weight [g]	Part No.	Type
[mm]	$\varnothing$ D11	$\pm 0.1$				H13							
32	12	15	30	10.5	15	6.6	18	32	46	4	200	161 874	CRLNZG-32
40, 50	16	18	36	12	18	9	21	36	55	4	330	161 875	CRLNZG-40/50
63, 80	20	20	40	13	20	11	23	42	65	4	440	161 876	CRLNZG-63/80
100/125	25	25	50	16	24.5	14	28.5	50	75	4	740	161 877	CRLNZG-100/125

1) Corrosion resistance class 4 according to Festo standard 940 070  
Components requiring higher corrosion resistance. Parts used with aggressive media, e.g. food or chemical industry. These applications should be supported with special tests with the media if required.

# Accessories for corrosion-resistant cylinders

Technical data



## Clevis foot CRLBN

Material:  
High-alloy steel  
Free of copper, PTFE and silicone

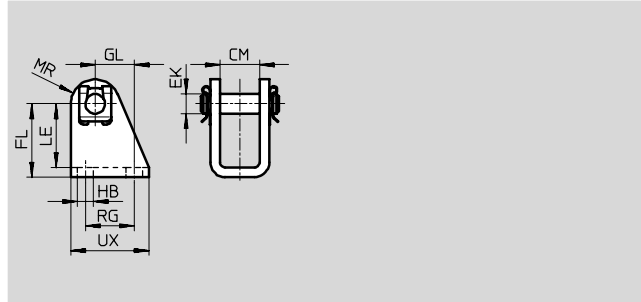

Dimensions and ordering data													
For Ø	CM	EK Ø	FL	GL	HB	LE	MR	RG	UX	CRC <sup>1)</sup>	Weight [g]	Part No.	Type
[mm]													
12, 16	12.1	6	27 +0.3/-0.2	13	5.5	24	7	15	25	4	55	161 862	CRLBN-12/16
20, 25	16.1	8	30 +0.4/-0.2	16	6.6	26	10	20	32	4	62	161 863	CRLBN-20/25
32	16.1	10	35 +0.4/-0.2	18.5	6.6	31	11	24	35	4	107	195 866	CRLBN-32
40	18.1	12	40 +0.4/-0.2	24.5	9	35	13	30	45	4	184	195 867	CRLBN-40
50, 63	21.1	16	45 +0.5/-0.2	28	9	39	14	34	50	4	289	195 868	CRLBN-50/63

1) Corrosion resistance class 4 according to Festo standard 940 070  
Components requiring higher corrosion resistance. Parts used with aggressive media, e.g. food or chemical industry. These applications should be supported with special tests with the media if required.

## Clevis foot mounting CRLNG

Material:  
High-alloy steel  
Free of copper, PTFE and silicone

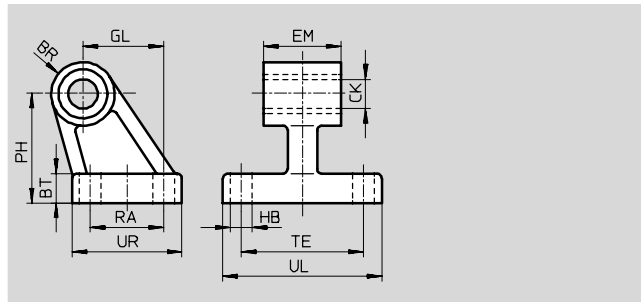

Dimensions and ordering data																	
For Ø	BR	BT	CK Ø	EB Ø	EM	GL	HB Ø	OF	PH	RA	TE	UL	UR	CRC <sup>1)</sup>	Weight [g]	Part No.	Type
[mm]			D11	H13	-0.4		H13										
32	10	8	10	-	25.8	21	6.6	-	32	18	38	51	31	4	120	161 840	CRLNG-32
40	11	10	12	-	27.8	24	6.6	-	36	22	41	54	35	4	160	161 841	CRLNG-40
50	12	12	12	-	31.8	33	9	-	45	30	50	65	45	4	280	161 842	CRLNG-50
63	15	12	16	15	39.8	37	9	10.8	50	35	52	67	50	4	375	161 843	CRLNG-63
80	15	14	16	18	49.8	47	11	12.7	63	40	66	86	60	4	580	161 844	CRLNG-80
100	19	15	20	18	59.8	55	11	13.7	71	50	76	96	70	4	935	161 845	CRLNG-100
125	22	20	25	20	69.8	70	14	18.6	90	60	94	124	90	4	2,530	176 951	CRLNG-125

1) Corrosion resistance class 4 according to Festo standard 940 070  
Components requiring higher corrosion resistance. Parts used with aggressive media, e.g. food or chemical industry. These applications should be supported with special tests with the media if required.

# Accessories for corrosion-resistant cylinders



Technical data

## Clevis foot CRSBS

Material:  
High-alloy steel

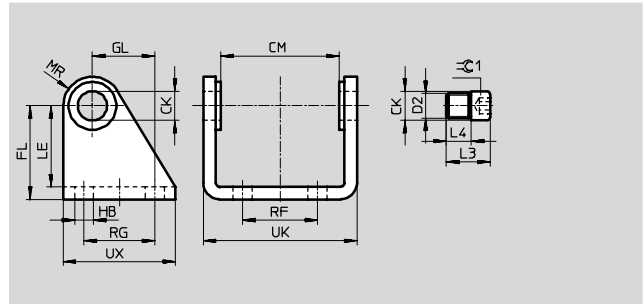

Dimensions and ordering data											
For Ø	CK	CM	D1	D2	FL	GL	H1	HB	L3	L4	LE
[mm]	Ø H8/f7		Ø					Ø			
32	10	38.1	15	M8x1	35	20	4	7	14.5	6.5	31
40	12	46.1	20	M10x1	40	27	5	9	18.5	9	36
50	14	57.1	23	M12x1.5	45	30	6	9	23	12	39
63	16	70.4	23	M14x1.5	50	34	6	9	29	16	44

For Ø	MR	RF	RG	UK	UX	≈C1	CRC <sup>1)</sup>	Weight	Part No.	Type
[mm]								[g]		
32	12	20	24	50.1	40	5	4	130	<b>162 955</b>	<b>CRSBS-32</b>
40	13	28	30	60.1	50	6	4	200	<b>162 956</b>	<b>CRSBS-40</b>
50	14	36	34	74.1	54	6	4	310	<b>162 957</b>	<b>CRSBS-50</b>
63	15	42	35	88.1	65	8	4	440	<b>162 958</b>	<b>CRSBS-63</b>

1) Corrosion resistance class 4 according to Festo standard 940 070  
Components requiring higher corrosion resistance. Parts used with aggressive media, e.g. food or chemical industry. These applications should be supported with special tests with the media if required.

## Pivot bolt CRGBS

For swivel mounting

Material:  
High-alloy steel  
Free of copper, PTFE and silicone



Dimensions and ordering data									
For Ø	D1	L1	L2	TD	≈C1	CRC <sup>1)</sup>	Weight	Part No.	Type
[mm]				Ø f8			[g]		
32	M8x1	14.5	6.5 ±0.1	10	5	4	10	<b>163 132</b>	<b>CRGBS-32</b>
40	M10x1	18.5	9 ±0.1	12	6	4	20	<b>163 133</b>	<b>CRGBS-40</b>
50	M12x1.5	23	12 ±0.2	14	6	4	40	<b>163 134</b>	<b>CRGBS-50</b>
63	M14x1.5	29	16 ±0.2	16	8	4	65	<b>163 135</b>	<b>CRGBS-63</b>

1) Corrosion resistance class 4 according to Festo standard 940 070  
Components requiring higher corrosion resistance. Parts used with aggressive media, e.g. food or chemical industry. These applications should be supported with special tests with the media if required.

# Accessories for corrosion-resistant cylinders

Technical data



## Clevis foot CRLMC

Material:  
High-alloy steel  
Free of copper, PTFE and silicone

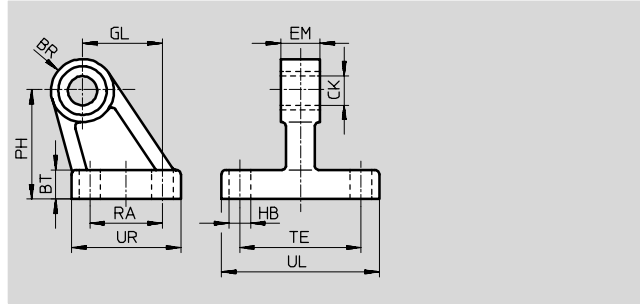

Dimensions and ordering data																	
For Ø	BR	BT	CK	EB	EM	GL	HB	OF	PH	RA	TE	UL	UR	CRC <sup>1)</sup>	Weight	Part No.	Type
[mm]			Ø D11	Ø H13	-0.4		Ø H13								[g]		
32	10	8	10	-	10	21	6.6	-	32	18	38	51	31	4	101	<b>197 320</b>	<b>CRLMC-32</b>
40	11	10	12	-	12	24	6.6	-	36	22	41	54	35	4	139	<b>197 321</b>	<b>CRLMC-40</b>
50	12	12	12	-	16	33	9	-	45	30	50	65	45	4	242	<b>197 322</b>	<b>CRLMC-50</b>
63	15	12	16	15	16	37	9	10.8	50	35	52	67	50	4	303	<b>197 323</b>	<b>CRLMC-63</b>
80	15	14	16	18	20	47	11	12.7	63	40	66	86	60	4	515	<b>197 324</b>	<b>CRLMC-80</b>
100	19	15	20	18	20	55	11	13.7	71	50	76	96	70	4	761	<b>197 325</b>	<b>CRLMC-100</b>

1) Corrosion resistance class 4 according to Festo standard 940 070  
Components requiring higher corrosion resistance. Parts used with aggressive media, e.g. food or chemical industry. These applications should be supported with special tests with the media if required.

## Ring nut CR

Material:  
High-alloy steel  
Free of copper, PTFE and silicone

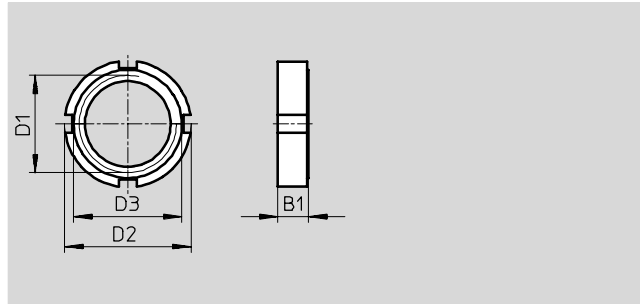
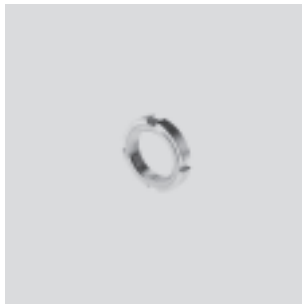

Dimensions and ordering data							
For Ø	B1	D1	D2	D3	CRC <sup>1)</sup>	Weight	Part No. Type
[mm]						[g]	
32	8	M30x1.5	42	36	4	40	<b>197 326 CR-M30x1,5</b>
40	10	M38x1.5	50	48	4	61	<b>197 327 CR-M38x1,5</b>
50, 63	10	M45x1.5	60	56	4	89	<b>197 328 CR-M45x1,5</b>
80, 100	13	M50x2	75	67	4	228	<b>197 329 CR-M50x2</b>

1) Corrosion resistance class 4 according to Festo standard 940 070  
Components requiring higher corrosion resistance. Parts used with aggressive media, e.g. food or chemical industry. These applications should be supported with special tests with the media if required.

Cylinders with piston rods  
Accessories for corrosion-resistant cylinders

2.8

# Accessories for corrosion-resistant cylinders



Technical data

Ordering data – Piston rod attachments				Technical data → 1 / 10.3-5			
	For Ø	Part No.	Type		For Ø	Part No.	Type
<b>Rod eye CRSGS</b>				<b>Rod clevis CRSG</b>			
	12, 16	195 580	CRSGS-M6		12, 16	13 567	CRSG-M6
	20	195 581	CRSGS-M8		20	13 568	CRSG-M8
	32	195 582	CRSGS-M10x1,25		32	13 569	CRSG-M10x1,25
	40	195 583	CRSGS-M12x1,25		40	13 570	CRSG-M12x1,25
	50, 63	195 584	CRSGS-M16x1,5		50, 63	13 571	CRSG-M16x1,5
	80, 100	195 585	CRSGS-M20x1,5		80, 100	13 572	CRSG-M20x1,5
	125	195 586	CRSGS-M27x2		125	185 361	CRSG-M27x2

Ordering data – Proximity sensor, magnetic reed			Technical data → 1 / 10.2-68	
	Electrical connection	Cable length	Part No.	Type
	Cable	[m]		
	NO contact			
	Resistant to corrosion			
	3-wire	2.5	161 775	CRSMEO-4-K-LED-24

Ordering data – Mounting kit				Technical data → 1 / 10.2-70			
	For Ø	Part No.	Type		For Ø	Part No.	Type
<b>Mounting kit CRSMBR</b>				<b>Mounting kit CRSMB</b>			
	12	164 581	CRSMBR-12		32	161 763	CRSMB-32
	16	164 582	CRSMBR-16		40	161 764	CRSMB-40
	20	164 583	CRSMBR-20		50	161 765	CRSMB-50
	25	164 584	CRSMBR-25		63	161 766	CRSMB-63
	32	163 888	CRSMBR-32		80	161 767	CRSMB-80
	40	163 889	CRSMBR-40		100	161 768	CRSMB-100
	50	163 890	CRSMBR-50		125	185 365	CRSMB-125
	63	163 891	CRSMBR-63				

Ordering data – Proximity sensor, magneto-resistive				Technical data → 1 / 10.2-21	
	Switch output	Electrical connection	Cable length	Part No.	Type
		Cable	[m]		
	NO contact				
	PNP	3-wire	2.5	525 563	CRSMT-8-PS-K2,5-LED-24
			5.0	525 564	CRSMT-8-PS-K5-LED-24

Ordering data – Mounting kit		Technical data → 1 / 10.2-40	
		Part No.	Type
		525 565	CRSMB-8-32/100

Ordering data – One-way flow control valves				Technical data → Volume 2	
	Connection	Material	Part No.	Type	
	Thread	For push-in fitting			
	M5	CRQS/CRQSL/CRQST	Electrolytically polished stainless steel casting	161 403	CRGRLA-M5-B
	G1/8			161 404	CRGRLA-1/8-B
	G1/4			161 405	CRGRLA-1/4-B
	G3/8			161 406	CRGRLA-3/8-B
	G1/2			161 407	CRGRLA-1/2-B

Cylinders with piston rods  
Accessories for corrosion-resistant cylinders

2.8

# Accessories for corrosion-resistant cylinders

Technical data

Ordering data – Air reservoir				Technical data → Volume 3	
	Connection	Volume [l]	Material	Part No.	Type
	Thread				
	G1/8	0.1	High-alloy stainless steel	160 233	CRVZS-0.1
	G1/4	0.4		160 234	CRVZS-0.4
	G1/4	0.75		160 235	CRVZS-0,75
	G1/2	2		160 236	CRVZS-2
	G1, G3/8	5		192 159	CRVZS-5
	G1, G3/8	10		160 237	CRVZS-10

Ordering data – Compressed air tubing		Technical data → Volume 3
	Standard O.D. tubing to CETOP RP 54 P	PLN, PFAN