



- Steel design
- To EC directive 87/404
- To EC standard EN 286

Air reservoirs CRVZS

Technical data

Function

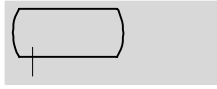

- When these reservoirs are combined with time-delay and flow control valves, it is possible to achieve very long delay times.
- The reservoirs can be used to compensate for pressure fluctuations, and act as accumulators in the event of sudden air consumption.

Temperature range
-10 ... +100 °C

Operating pressure
-0.95 ... 16 bar

Air reservoir tested in accordance with EC directive 87/404 and designed to EC standard EN 286-1.



Technical data							
Type	CRVZS-0.1	CRVZS-0.4	CRVZS-0.75	CRVZS-2	CRVZS-5	CRVZS-10	CRVZS-20
Pneumatic connection	G $\frac{1}{8}$	G $\frac{1}{4}$	G $\frac{1}{4}$	G $\frac{1}{2}$	G1		
Condensate drain connection	-				G $\frac{3}{8}$		
Operating medium	Air or nitrogen						
Design	Seamless vessel						
Type of mounting	Retaining clips			Via through-holes in mounting bracket			
Volume $\pm 10\%$ [l]	0.1	0.4	0.75	2	5	10	20
Operating pressure [bar]	-0.95 ... +16						
CE symbol for pressure units	-				97/23/EC		
Temperature range [°C]	-10 ... +100 (observe operating range of tubing and pipe)						
Material	Stainless steel						
Corrosion resistance CRC ¹⁾							3
Weights [g]	226	543	736	1681	3581	6459	

1) Corrosion resistance class 3 according to Festo standard 940 070
Components requiring higher corrosion resistance. External visible parts in direct contact with industrial atmospheres or media such as solvents and cleaning agents, with a predominantly functional requirement for the surface.

Dimensions

Download CAD data → www.festo.com/en/engineering

CRVZS-0.1/CRVZS-0.4/CRVZS-0.75

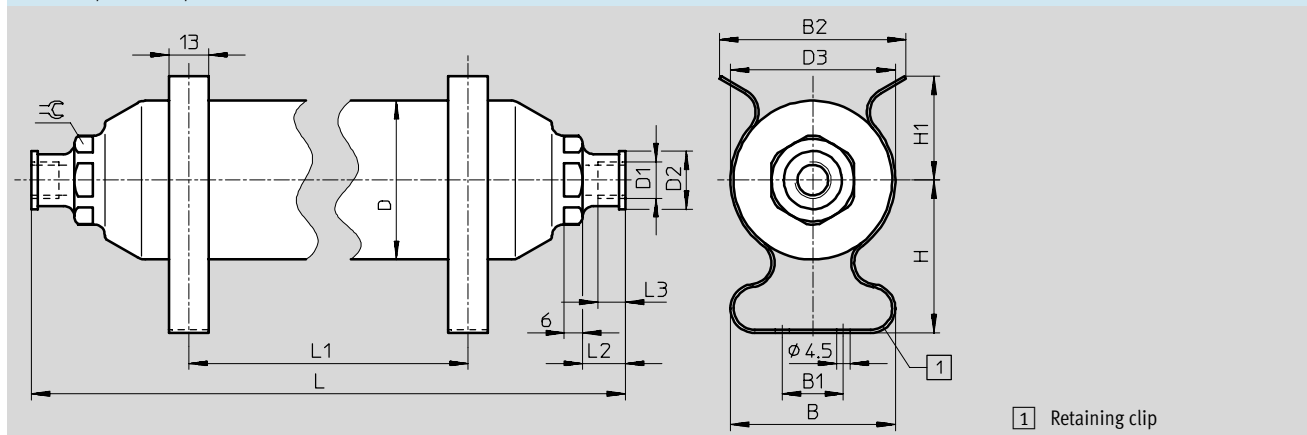

Type	B ± 2	B1	B2 ± 2	D \varnothing	D1	D2 \varnothing	D3 \varnothing	H ± 1	H1 ± 1	L ± 1	L1 min.	L1 max.	L2	L3	\varnothing
CRVZS-0.1	51	14	-	40	G $\frac{1}{8}$	15	42	43	28	132	13	50	10	6	19
CRVZS-0.4	54	14	-	52	G $\frac{1}{4}$	19	54	50	34	240	13	150	14	9	27
CRVZS-0.75	60	20	79	70	G $\frac{1}{4}$	19	72	61	34	248	13	140	14	9	27

Air reservoirs CRVZS

Technical data

Dimensions

Download CAD data → www.festo.com/en/engineering

CRVZS-2

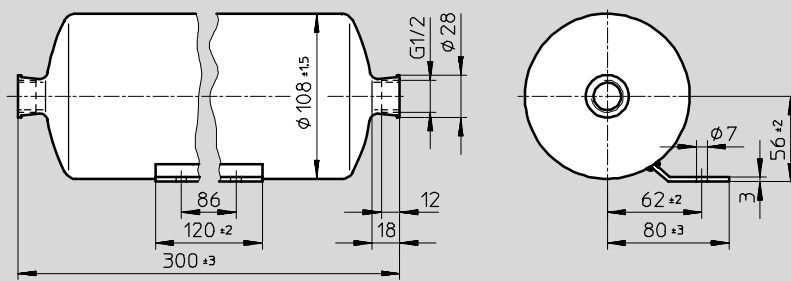

CRVZS-5

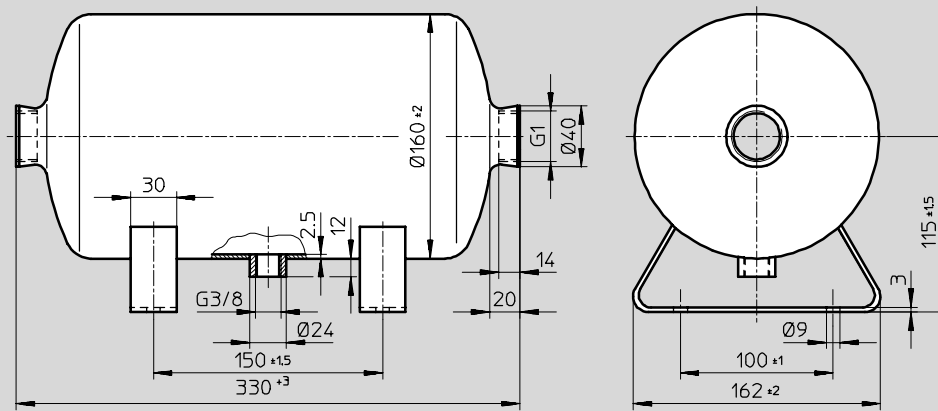

CRVZS-10/CRVZS-20

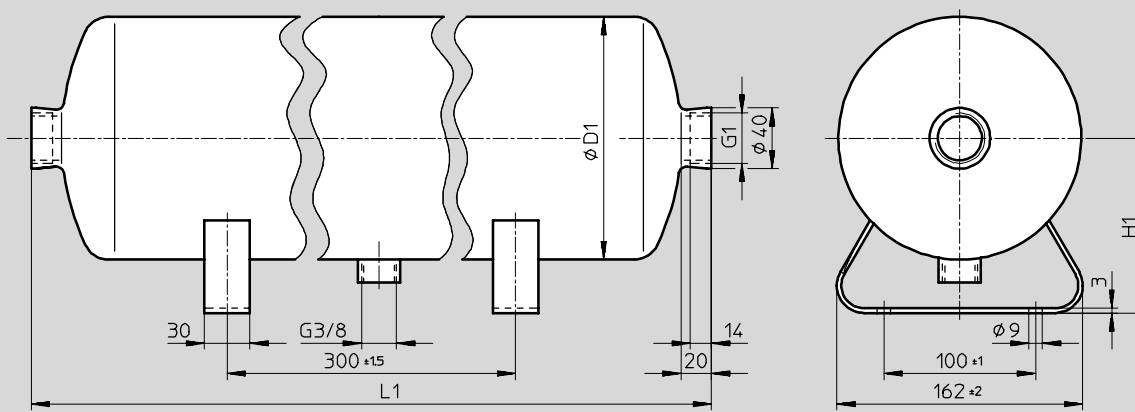

Type	D1 ± 2	H1 ± 1.5	L1 ± 3
CRVZS-10	160	115	558
CRVZS-20	194	136	740

Ordering data

Volume [l]	Part No.	Type	Volume [l]	Part No.	Type
0.1	160 233	CRVZS-0.1	5	192 159	CRVZS-5
0.4	160 234	CRVZS-0.4	10	160 237	CRVZS-10
0.75	160 235	CRVZS-0.75	20	534 845	CRVZS-20
2	160 236	CRVZS-2			New

Core Range

Air reservoirs VZS

Technical data



Function

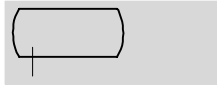

- When these reservoirs are combined with time-delay and flow control valves, it is possible to achieve very long delay times.
- The reservoirs can be used to compensate for pressure fluctuations, and act as accumulators in the event of sudden air consumption.

- - Temperature range
-10 ... +100 °C

- - Operating pressure
0 ... 16 bar

Air reservoir tested in accordance with EC directive 87/404 and designed to EC standard EN 286-1.



Technical data		VZS-5-B	VZS-10-B	VZS-20-B
Type		VZS-5-B	VZS-10-B	VZS-20-B
Pneumatic connection		G1		
Condensate drain connection		G $\frac{3}{8}$		
Operating medium		Air or nitrogen		
Design		Welded vessel		
Type of mounting		Via through-hole in mounting bracket		
Volume $\pm 10\%$	[l]	5	10	20
Operating pressure	[bar]	0 ... 16		
Temperature range	[°C]	-10 ... +100 (observe operating range of tubing and pipe)		
Material		Steel		
Weights	[g]	6720	6500	8500

Dimensions Download CAD data → www.festo.com/en/engineering

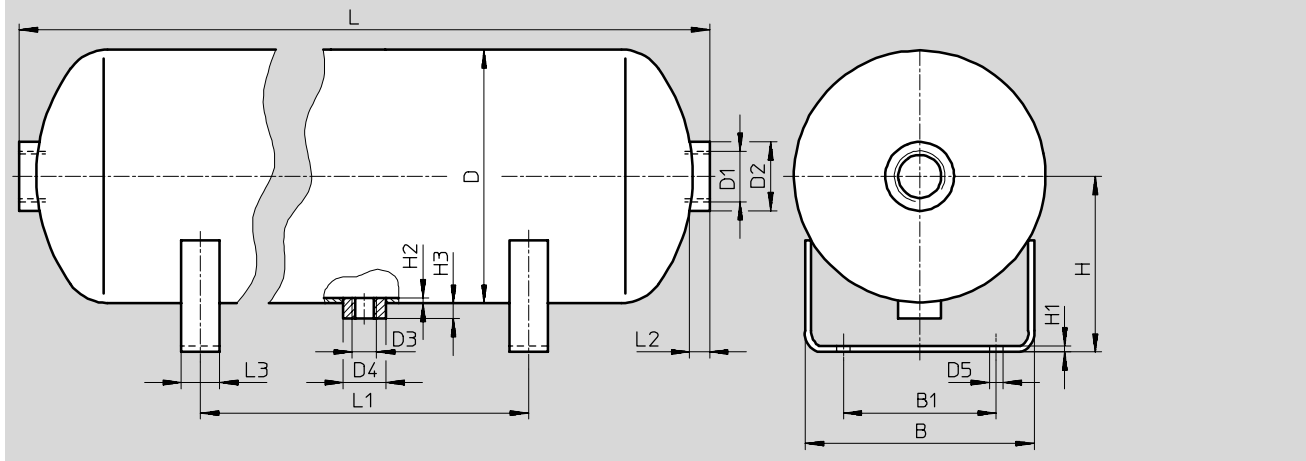

Type	B ± 2	B1 ± 2	D ± 4 \varnothing	D1	D2 \varnothing	D3	D4 \varnothing	D5 \varnothing	H ± 1.5	H1	H2 min.	H3	L	L1 ± 1.5	L2	L3
VZS-5-B	130	90	154	G1	45	G $\frac{3}{8}$	28	9	115	4	2	12	348 ± 4	150	18	25
VZS-10-B	150	100	166						115				558 ± 5			
VZS-20-B	150	100	206						146.5				696 ± 6			

Ordering data	
Volume [l]	Part No. Type
5	192 160 VZS-5-B
10	151 923 VZS-10-B
20	192 161 VZS-20-B