



- Adjustable or self-adjusting
- With linear or progressive characteristic
- Stop elements:  
combination of cushioning and end-position sensing
- Specified types in accordance with ATEX directive for potentially explosive atmospheres  
→ [www.festo.com/en/ex](http://www.festo.com/en/ex)

# Cushioning components

Features



Cushioning components

9.0

## Shock absorber

**YSR – adjustable**



With these hydraulic shock absorbers, impact energy is dissipated by displacing oil via a pressure-controlled valve. A built-in compression spring returns the piston rod to the initial position. Cushioning action can be infinitely adjusted by means of an adjusting ring. Adjustment can be performed during operation. The shock absorbers can be used as end stops, subject to the specified maximum impact force.

## YSR-C – self-adjusting



In the case of this self-adjusting hydraulic shock absorber, energy acting upon the piston rod has the effect of displacing oil through a combination of a pressure operated pressure relief valve and a position dependent flow control valve. This ensures automatic adaptation to every possible cushioning requirement within the permissible energy limits. An integrated compression spring returns the piston rod to its initial position.

## YSRW –self-adjusting, progressive



Unlike the YSR-...-C shock absorber, these shock absorbers have progressive characteristics. This facilitates a gradually rising cushioning force with a longer stroke. Vibration is thus significantly reduced at handling systems and enables the realisation of shorter cycle times.

## Stop elements with shock absorber

**YSRWJ –self-adjusting, progressive**



These limit stops include three functions:

- Cushioning with self-adjusting, progressive hydraulic shock absorber (YSRW)
- Adjustable cushioning stroke
- End-position sensing with proximity sensors SME-/SMT-8
- Precision end-position adjustment

Type YSRWJ limit stops can be used for a wide variety of applications in the handling and assembly technology system.

## Hydraulic cushioning cylinders

**YDR – adjustable**





With the hydraulic cushioning cylinders, energy acting on the piston rod is dissipated by displacing oil through a flow control valve. A built-in compression spring returns the piston rod to the initial position. The braking speed can be infinitely adjusted by means of an adjusting ring. They are suitable for slow feed speeds in the range of 0.1 m/s.

# Cushioning components

Product range overview

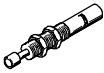
FESTO

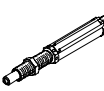
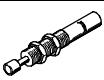
Function	Design	Type	∅ [mm]	Stroke [mm]	Energy absorption per stroke [J]	Cushioning characteristic curve	Position sensing A	Free of copper, PTFE and silicone CT	→ Page
Shock absorber	<b>Adjustable</b>								
		YSR	8, 12, 16, 20, 25, 32	8, 12, 20, 25, 40, 60	4 ... 380	Adjustable	-	-	1 / 9.1-0
	<b>Self-adjustable</b>								
		YSR-C	5, 7, 8, 10, 12, 16, 20, 25, 32	5, 8, 10, 12, 20, 25, 40, 60	1 ... 380	Rapidly increasing cushioning force curve	-	■	1 / 9.1-4
		YSRW	5, 7, 8, 10, 12, 16, 20	8, 10, 14, 17, 20, 26, 34	1.3 ... 70	Slowly increasing cushioning force curve	-	■	1 / 9.1-8
Stop element	<b>Self-adjustable</b>								
		YSRWJ	5, 7, 8	7.5, 9.5, 13.5	1 ... 3	Slowly increasing cushioning force curve	■	-	1 / 9.1-12
Hydraulic cushioning cylinders	<b>Adjustable</b>								
		YDR	16, 20, 25, 32	20, 25, 40, 60	32 ... 384	Linear, adjustable	-	-	1 / 9.2-0

Cushioning components

9.0

# Shock absorbers YSR

Peripherals overview and type codes

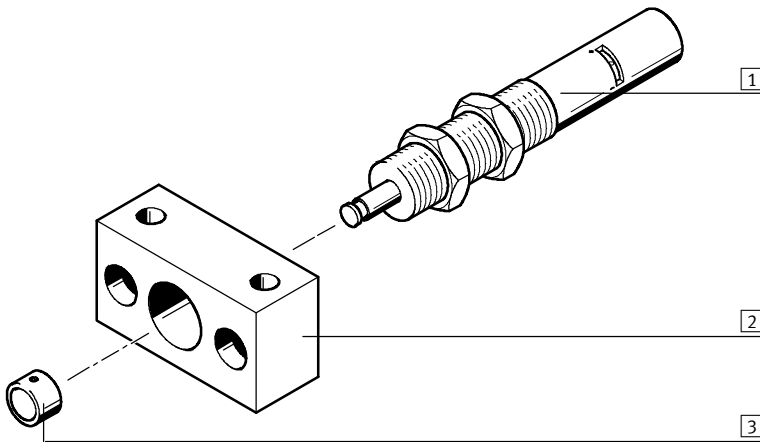

Accessories			
	Type	Brief description	→ Page
1	Shock absorber YSR	Hydraulic shock absorber with adjustable cushioning characteristic	1 / 9.1-1
2	Mounting flange YSRF	Mounting option for shock absorber	1 / 9.3-0
3	Buffer YSRP	For the protection of piston rod	1 / 9.3-2
-	Oil gun YSR-OEP	For topping up oil	1 / 9.3-2
-	Special oil OFSB-1	Replacement oil	1 / 9.3-2

YSR		-	12	-	12	-	
<b>Type</b>							
YSR	Shock absorber						
<b>∅[mm]</b>							
<b>Stroke [mm]</b>							
<b>Buffer</b>							
D	With buffer						

# Shock absorbers YSR

Data sheet

FESTO

Function

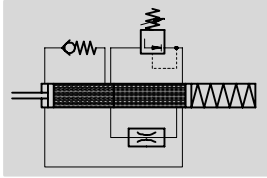

- $\varnothing$  - Diameter  
8 ... 32 mm
- | - Stroke length  
8 ... 60 mm



General technical data						
Piston $\varnothing$	8	12	16	20	25	32
Stroke [mm]	8	12	20	25	40	60
Mode of operation	Hydraulic shock absorbers with return spring					
Cushioning	Adjustable					
Type of mounting	Thread with locknut					
Impact velocity [m/s]	0.1 ... 3					
Product weight [g]	40	120	240	420	860	1,600
Ambient temperature [°C]	-10 ... +80					

Reset times [s]						
Piston $\varnothing$	8	12	16	20	25	32
Short <sup>1)</sup>	≤ 0.4					
Long <sup>2)</sup>	≤ 1					

- 1) Piston rod retracted for short period ≤ 30 s
- 2) Piston rod retracted for longer period ≤ 6 h

Forces [N]						
Piston $\varnothing$	8	12	16	20	25	32
Max. stop force in end positions	400	900	1,600	2,500	4,000	6,400
Resetting force	3	25	20	25	30	35

Energies [J]						
Piston $\varnothing$	8	12	16	20	25	32
Max. energy absorption per stroke	4	10.8	32	62.5	160	380
Max. energy absorption per hour	24,000	77,000	130,000	180,000	293,000	483,000

# Shock absorbers YSR

Data sheet



## Materials

Sectional view

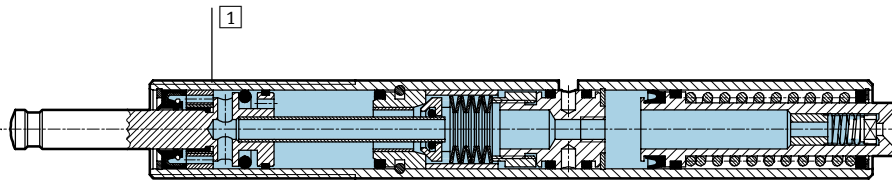

## Shock absorber

1	Housing	Galvanised steel
-	Seals	Perbunan, polyurethane

## Selection graph for shock absorbers with infinitely adjustable cushioning YSR

Impact velocity dependent on mass m

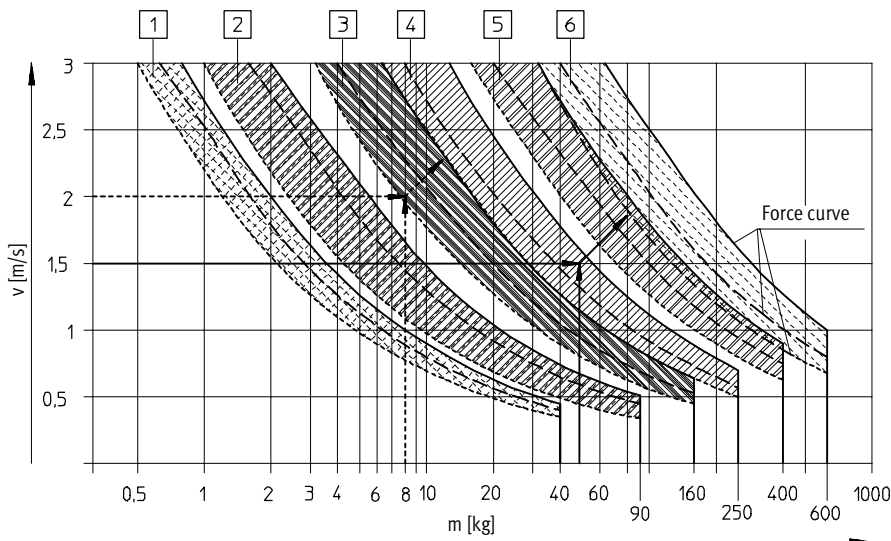

Three force curves are shown for each shock absorber. Interim values must be calculated by averaging. The

arrows relate to the examples starting on page → 1 / 9.3-6.

Shock absorber	Max. stop force in end position	Force A =	Force A =	Force A =
YSR-8-8-D	400 N	0 N	100 N	200 N
YSR-12-12	900 N	0 N	200 N	500 N
YSR-16-20	1,600 N	0 N	500 N	800 N
YSR-20-25	2,500 N	0 N	800 N	1,200 N
YSR-25-40	4,000 N	0 N	1 200 N	2,000 N
YSR-32-60	6,400 N	0 N	2,000 N	3,000 N

# Shock absorbers YSR

Data sheet



Download CAD data → [www.festo.com/en/engineering](http://www.festo.com/en/engineering)

**Dimensions**  
YSR-8-8-D

1 Cushioning adjustment  
4 - Less cushioning  
5 + More cushioning  
7 Buffer (included in scope of delivery)

YSR ...

1 Cushioning adjustment  
2 Oil reservoir  
3 Oil top-up facility  
4 - Less cushioning  
5 + More cushioning  
6 Polyurethane insert  
7 Buffer YSRP (to be ordered separately)

∅	B1	D1	D2	D3	L1	L2	L3
[mm]			∅	∅			
8	-	-	-	-	-	-	-
12	5	M15x1	6	12	119	18	36
16	6	M20x1.25	8	16	151	28	53
20	8	M24x1.25	10	20	174	35	60
25	10	M30x1.5	12	25	227	52	80
32	12	M37x1.5	15	32	275	75	108

∅	L4	L5	L6	L7	∅ 1	∅ 2	Max. tightening torque ∅ 1
[mm]		max.		±0.4			[Nm]
8	-	-	-	-	-	-	5
12	52.5	5	3	10	19	2	20
16	62.5	5	5	13.5	24	2.5	35
20	72.5	6	6	17	30	3	60
25	89.8	9	10	20.5	36	4	80
32	106.3	13	15	26	46	4	100

**Ordering data**

∅	Part No.	Type
[mm]		
8	189 980	YSR-8-8-D
12	10 867	YSR-12-12
16	10 868	YSR-16-20
20	10 869	YSR-20-25
25	10 870	YSR-25-40
32	10 871	YSR-32-60

# Shock absorber YSR-C

Peripherals overview and type codes

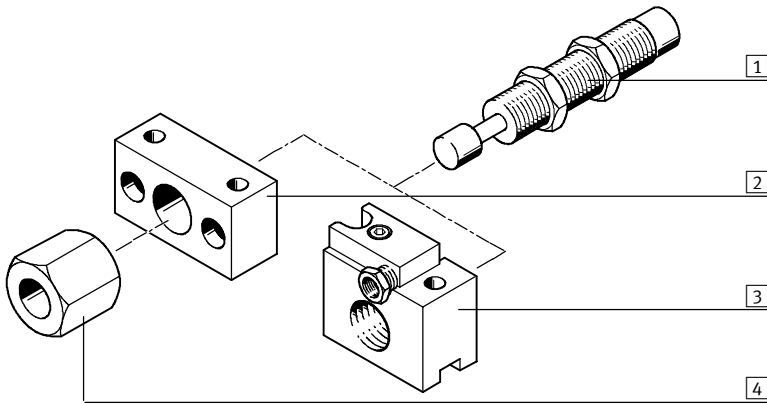

Accessories			
	Type	Brief description	→ Page
1	Shock absorber YSR-C	Hydraulic shock absorber with rapidly increasing cushioning force curve	1 / 9.1-5
2	Mounting flange YSRF	Mounting option for shock absorber	1 / 9.3-0
3	Mounting flange YSRF-S	Mounting option for shock absorber with attached stop sleeve and position sensing	1 / 9.3-1
4	Stop limiters YSRA	Stroke limiter for shock absorber	1 / 9.3-2

	YSR	-	16	-	20	-	C
<b>Type</b>							
YSR	Shock absorber						
<b>∅ [mm]</b>							
<b>Stroke [mm]</b>							
<b>Version</b>							
C							



# Shock absorber YSR-C

Data sheet

FESTO

Function

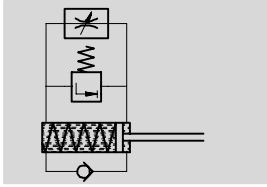

- $\varnothing$  - Diameter  
5 ... 32 mm
- | - Stroke length  
5 ... 60 mm



General technical data									
Piston $\varnothing$	5	7	8	10	12	16	20	25	32
Stroke [mm]	5	5	8	10	12	20	25	40	60
Mode of operation	Hydraulic shock absorbers with return spring								
Cushioning	Self-adjustable								
Type of mounting	Thread with locknut								
Impact velocity [m/s]	0.05 ... 2		0.05 ... 3						
Product weight [g]	9	18	30	50	70	140	240	600	1,250
Ambient temperature [°C]	-10 ... +80								

Reset time [s]									
Piston $\varnothing$	5	7	8	10	12	16	20	25	32
Reset time <sup>1)</sup>	≤ 0.2							≤ 0.4	≤ 0.5

- 1) The specified technical data refers to ambient temperature. At higher temperatures in the 80 °C range, the max. mass and the cushioning work must be reduced by 50% approx. At -10 °C, the reset time may be up to 1 second.

Forces [N]									
Piston $\varnothing$	5	7	8	10	12	16	20	25	32
Min. insertion force <sup>1)</sup>	5.5	8.5	15	20	27	42	80	143	120
Max. stop force <sup>2)</sup> in end positions	200	300	500	700	1,000	2,000	3,000	4,000	6,000
Min. resetting force <sup>3)</sup>	0.7	1	3.1	4.5	6	6	14	14	21

- 1) This is the minimum force that must be applied so that the shock absorber is pushed exactly into the retracted end position. This value is reduced correspondingly in the event of an extended external end-position.  
 2) If the max. stop force is exceeded, a fixed stop (e.g. YSRA) 0.5 mm must be fitted before the end of stroke.  
 3) This is the maximum force which may act upon the piston rod, allowing for full extension of the shock absorber (e.g. protruding stem).

Energies [J]									
Piston $\varnothing$	5	7	8	10	12	16	20	25	32
Max. energy absorption per stroke	1	2	3	6	10	30	60	160	380
Max. energy absorption per hour	8,000	12,000	18,000	26,000	36,000	64,000	92,000	150,000	220,000

Mass range [kg]									
Piston $\varnothing$	5	7	8	10	12	16	20	25	32
Permissible mass range up to	1.5	5	15	25	45	90	120	200	400

# Shock absorber YSR-C

Data sheet



## Materials

Sectional view

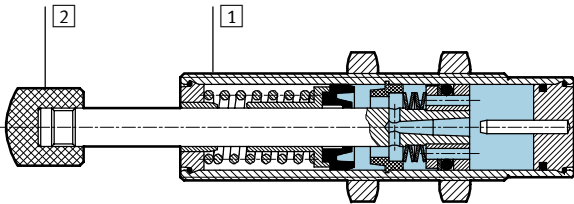

Piston Ø		5	7	8	10	12	16	20	25	32	
1	Housing	Brass, nickel-plated			Galvanised steel						
2	Buffer	Polyacetate			Polyamide				Steel with polyurethane		
-	Seals	Perbunan, polyurethane									
	Material note	Free of copper, PTFE and silicone								-	

Cushioning components  
Shock absorbers

## 9.1

### Selection graph for self-adjusting shock absorbers YSR-C

Impact velocity dependent on mass m

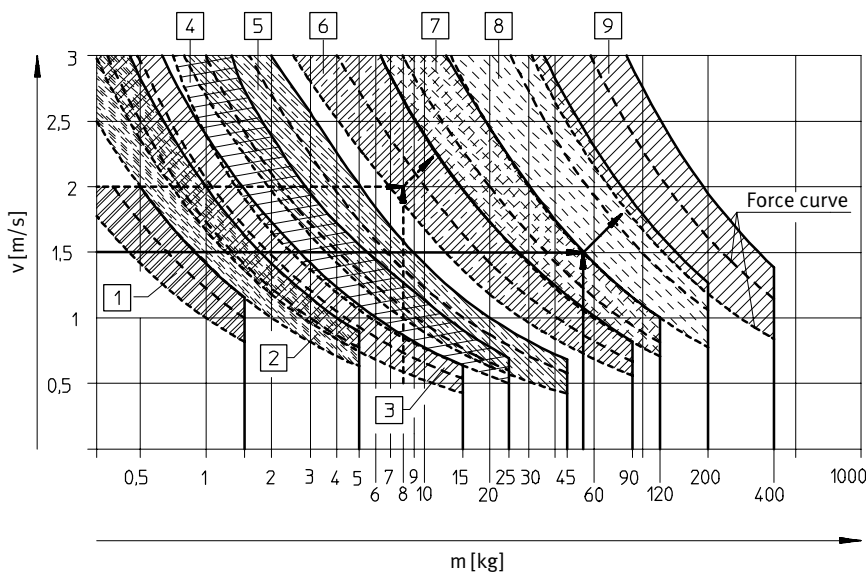

- 1 YSR-5-5
- 2 YSR-7-5-C
- 3 YSR-8-8-C
- 4 YSR-10-10-C
- 5 YSR-12-12-C
- 6 YSR-16-20-C
- 7 YSR-20-25-C
- 8 YSR-25-40-C
- 9 YSR-32-60-C

Three force curves are shown for each shock absorber. Interim values must be calculated by averaging. The

arrows relate to the examples starting on page → 1 / 9.3-6.

Shock absorber	Max. stop force in end position	Force A =	Force A =	Force A =
YSR-5-5-C	200 N	0 N	50 N	100 N
YSR-7-5-C	300 N	0 N	100 N	200 N
YSR-8-8-C	500 N	0 N	100 N	200 N
YSR-10-10-C	700 N	0 N	150 N	300 N
YSR-12-12-C	1,000 N	0 N	200 N	500 N
YSR-16-20-C	2,000 N	0 N	500 N	800 N
YSR-20-25-C	3,000 N	0 N	800 N	1,200 N
YSR-25-40-C	4,000 N	0 N	1,200 N	2,500 N
YSR-32-60-C	6,000 N	0 N	2,000 N	4,000 N

# Shock absorber YSR-C

Data sheet

FESTO

## Dimensions

Download CAD data → [www.festo.com/en/engineering](http://www.festo.com/en/engineering)

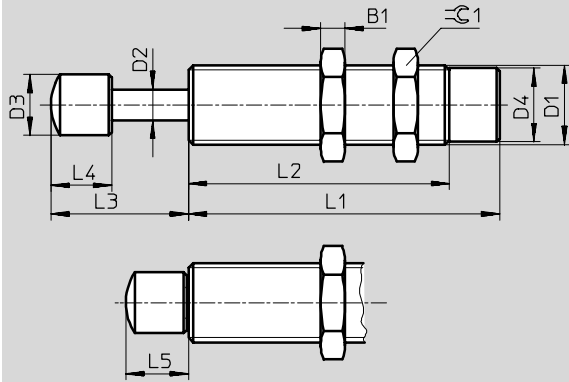

∅	B1	D1	D2	D3	D4	L1
[mm]			∅	∅	∅	±0.1
5	3	M8x1	2.5	5 ±0.1	6.7 ±0.05	29
7	3.5	M10x1	3	6 ±0.1	8.6 ±0.05	34
8	4	M12x1	4	8 ±0.2	10.4 ±0.1	46
10	5	M14x1	5	10 ±0.2	12.4 ±0.1	55
12	5	M16x1	6	12 ±0.2	14.5 ±0.1	64
16	6	M22x1.5	8	16 ±0.2	20 ±0.1	86
20	8	M26x1.5	10	20 ±0.2	24 ±0.1	104
25	10	M30x1.5	12	25 ±0.2	28 ±0.1	152
32	12	M37x1.5	15	32 ±0.2	35 ±0.1	207

∅	L2	L3	L4	L5	≈C1	Max. tightening torque ≈C1 [Nm]
[mm]	±0.3					
5	19	10.8 +0.6/-0.3	5.5 ±0.1	5.8 +0.55/-0.25	10	2
7	23	12.3 +0.7/-0.35	7 ±0.2	7.3 +0.55/-0.25	13	3
8	33	16.3 +0.7/-0.35	8 ±0.2	8.3 +0.55/-0.25	15	5
10	42	20.5 +0.7/-0.35	10 ±0.2	10.5 +0.55/-0.25	17	8
12	51	24.5 +0.7/-0.35	12 ±0.2	12.5 +0.55/-0.25	19	20
16	69	36.5 +0.7/-0.35	16 ±0.2	16.5 +0.55/-0.25	27	35
20	87	45.5 +0.7/-0.35	20 ±0.2	20.5 +0.55/-0.25	32	60
25	125	61.5 +1.25/-0.75	20.5 ±0.4	21.5 +0.95/-0.55	36	80
32	179	87 +1.25/-0.75	26 ±0.4	27 +0.95/-0.55	46	100

Ordering data		
∅	Part No.	Type
[mm]		
5	158 981	YSR-5-5-C <sup>1)</sup>
7	160 272	YSR-7-5-C <sup>1)</sup>
8	34 571	YSR-8-8-C <sup>1)</sup>
10	191 199	YSR-10-10-C <sup>1)</sup>
12	34 572	YSR-12-12-C <sup>1)</sup>
16	34 573	YSR-16-20-C <sup>1)</sup>
20	34 574	YSR-20-25-C <sup>1)</sup>
25	160 273	YSR-25-40-C
32	160 274	YSR-32-60-C

1) Free of copper, PTFE and silicone

# Shock absorber YSRW

Peripherals overview and type codes

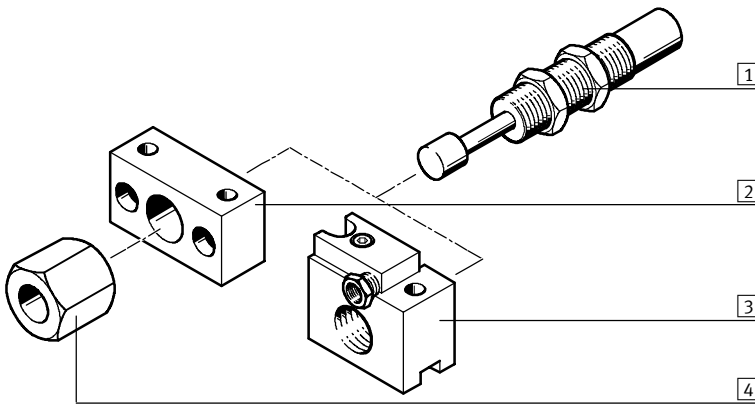

Accessories			
	Type	Brief description	→ Page
1	Shock absorber YSRW	Hydraulic shock absorber with progressive cushioning characteristic	1 / 9.1-9
2	Mounting flange YSRF	Mounting option for shock absorber	1 / 9.3-0
3	Mounting flange YSRF-S	Mounting option for shock absorber with attached stop sleeve and position sensing	1 / 9.3-1
4	Stop limiters YSRA	Stroke limiter for shock absorber	1 / 9.3-2

	YSRW	-	10	-	20
<b>Type</b>					
YSRW	Shock absorber				
<b>∅[mm]</b>					
<b>Stroke [mm]</b>					



# Shock absorber YSRW

Data sheet

FESTO

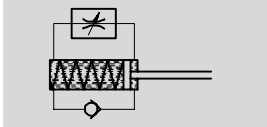
Function



-  - Diameter  
5 ... 16 mm
-  - Stroke length  
8 ... 26 mm



General technical data							
Piston $\varnothing$	5	7	8	10	12	16	20
Stroke [mm]	8	10	14	17	20	26	34
Mode of operation	Hydraulic shock absorbers with return spring						
Cushioning	Self-adjustable						
Type of mounting	Thread with locknut						
Impact velocity [m/s]	0.1 ... 2	0.1 ... 3					
Product weight [g]	8	18	34	54	78	190	330
Ambient temperature [°C]	-10 ... +80						

Reset time [s]							
Piston $\varnothing$	5	7	8	10	12	16	20
Reset time <sup>1)</sup>	≤ 0.2					≤ 0.3	

- 1) The specified technical data refers to ambient temperature. At higher temperatures in the 80 °C range, the max. mass and the cushioning work must be reduced by 50% approx. At -10 °C, the reset time may be up to 1 second.

Forces [N]							
Piston $\varnothing$	5	7	8	10	12	16	20
Min. insertion force <sup>1)</sup>	6.5	6.5	16	18	26	42	85
Max. stop force <sup>2)</sup> in end positions	200	300	500	700	1,000	2,000	3,000
Min. resetting force <sup>3)</sup>	1	1.7	3.5	3.8	5.2	6.6	10

- 1) This is the minimum force that must be applied so that the shock absorber is pushed exactly into the retracted end position. This value is reduced correspondingly in the event of an extended external end-position.  
 2) If the max. stop force is exceeded, a fixed stop (e.g. YSRA) 0.5 mm must be fitted before the end of stroke.  
 3) This is the maximum force which may act upon the piston rod, allowing for full extension of the shock absorber (e.g. protruding stem).

Energies [J]							
Piston $\varnothing$	5	7	8	10	12	16	20
Max. energy absorption per stroke	1.3	2.5	4	8	12	35	70
Max. energy absorption per hour	10,000	15,000	21,000	30,000	41,000	68,000	100,000

Mass range [kg]							
Piston $\varnothing$	5	7	8	10	12	16	20
Permissible mass range up to	2	5	10	20	30	50	80

# Shock absorber YSRW

Data sheet



Materials							
Piston Ø	5	7	8	10	12	16	20
Housing	Brass, nickel-plated			Galvanised steel			
Buffer	Polyamide						
Seals	Perbunan						
Material note	Free of copper, PTFE and silicone						

## Selection graph for self-adjusting shock absorbers with progressive characteristics YSRW

Impact velocity dependent on mass m

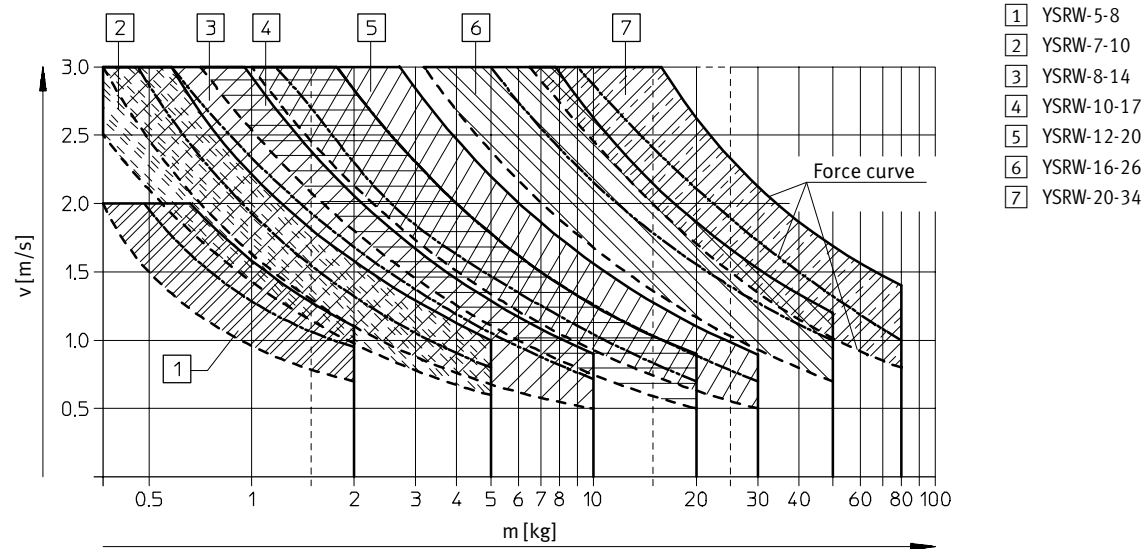

Three force curves are shown for each shock absorber. Interim values must be calculated by averaging.

Shock absorber	Max. stop force in end position	Force A = <u>        </u>	Force A = <u>        </u>	Force A = <u>        </u>
YSRW-5-8	200 N	0 N	50 N	100 N
YSRW-7-10	300 N	0 N	75 N	150 N
YSRW-8-14	500 N	0 N	100 N	200 N
YSRW-10-17	700 N	0 N	150 N	300 N
YSRW-12-20	1,000 N	0 N	200 N	400 N
YSRW-16-26	2,000 N	0 N	500 N	800 N
YSRW-20-34	3,000 N	0 N	800 N	1,200 N

# Shock absorber YSRW

Data sheet

FESTO

## Dimensions

Download CAD data → [www.festo.com/en/engineering](http://www.festo.com/en/engineering)

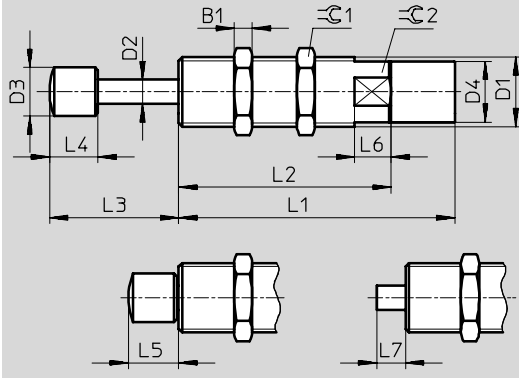

∅	B1	D1	D2 ∅	D3 ∅	D4 ∅	L1 ±0.1	L2 ±0.3	L3
[mm]								
5	3	M8x1	2.5	5 ±0.1	6.7 ±0.05	33.5	22.5	13.8 +0.6/-0.25
7	3.5	M10x1	3	6 ±0.1	8.6 ±0.05	41	30	17.3 +0.7/-0.25
8	4	M12x1	4	8 ±0.2	10.4 ±0.1	53	40	22.3 +0.7/-0.25
10	5	M14x1	5	10 ±0.2	12.4 ±0.1	62	49	27.5 +0.7/-0.25
12	5	M16x1	6	12 ±0.2	14.5 ±0.1	72.5	59.5	32.5 +0.7/-0.25
16	6	M22x1.5	8	16 ±0.2	20 ±0.1	91	70	42.5 +0.7/-0.35
20	8	M26x1.5	10	20 ±0.2	24 ±0.1	112	91	54.5 +0.7/-0.35

∅	L4	L5	L6 +0.5	L7	⌀1	⌀2	Max. tightening torque ⌀1 [Nm]
[mm]							
5	5.5 ±0.1	5.8 +0.35/-0.25	5	3.5 ±0.25	10	7	2
7	7 ±0.2	7.3 +0.35/-0.25	6	4.3 ±0.25	13	9	3
8	8 ±0.2	8.3 +0.4/-0.25	8	5.3 +0.3/-0.25	15	11	5
10	10 ±0.2	10.5 +0.4/-0.25	10	6.5 +0.3/-0.25	17	13	8
12	12 ±0.2	12.5 +0.4/-0.25	12	7.5 +0.3/-0.25	19	15	20
16	16 ±0.2	16.5 +0.4/-0.25	12	9.5 +0.3/-0.25	27	20	35
20	20 ±0.2	20.5 +0.4/-0.25	12	11.5 +0.3/-0.25	32	24	60

## Ordering data

∅ [mm]	Part No.	Type
5	191 192	YSRW-5-8
7	191 193	YSRW-7-10
8	191 194	YSRW-8-14
10	191 195	YSRW-10-17
12	191 196	YSRW-12-20
16	191 197	YSRW-16-26
20	191 198	YSRW-20-34

# Stop elements YSRWJ

Peripherals overview and type codes

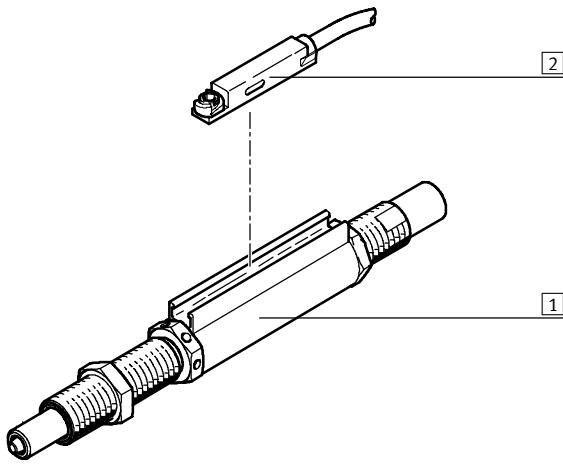

Accessories			
	Type	Brief description	→ Page
1	Stop element YSRWJ	Hydraulic shock absorber with progressive cushioning characteristic The cushioning length is adjustable	1 / 9.1-13
2	Proximity switches SME-/SMT-8	Sensing option for end positions	1 / 9.3-3

		YSRWJ	-	7	-	10	-	A
<b>Type</b>								
YSRWJ	Shock absorber							
<b>∅ [mm]</b>								
<b>Stroke [mm]</b>								
<b>Position sensing</b>								
A	Position sensing							



# Stop elements YSRWJ

Data sheet

FESTO

Function

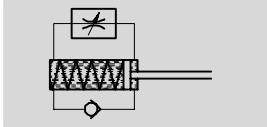

- $\varnothing$  - Diameter  
5 ... 8 mm
- | - Stroke length  
7.5 ... 13.5 mm



General technical data			
Piston $\varnothing$	5	7	8
Stroke [mm]	8	10	14
Mode of operation	A piston rod in front of the shock absorber transmits the force to the shock absorber. This serves as the end stop and actuates the proximity sensor via a magnet mounted on it.		
Cushioning	Self-adjustable		
Type of mounting	Thread with locknut		
Position sensing	Via proximity sensor		
Impact velocity [m/s]	0.05 ... 2	0.05 ... 3	
Repetition accuracy [mm]	0.02		
Product weight [g]	45	75	110
Ambient temperature [°C]	0 ... +60		

Reset time [s]			
Piston $\varnothing$	5	7	8
Reset time <sup>1)</sup>	≤ 0.2		

- 1) The specified technical data refers to ambient temperature. At higher temperatures in the 80 °C range, the max. mass and the cushioning work must be reduced by 50% approx. At -10 °C, the reset time may be up to 1 second.

Forces [N]			
Piston $\varnothing$	5	7	8
Min. insertion force <sup>1)</sup>	5	18	80
Max. stop force <sup>2)</sup> in end positions	200	300	500
Min. resetting force <sup>3)</sup>	1.5	2	3.5

- 1) This is the minimum force that must be applied so that the shock absorber is pushed exactly into the retracted end position.  
 2) Impact force may not exceed the maximum specified value.  
 3) This is maximum force that can be exerted on the piston rod so that the shock absorber advances fully.

Energies [J]			
Piston $\varnothing$	5	7	8
Max. energy absorption per stroke	1	2	3
Max. energy absorption per hour	10,000	15,000	21,000

Mass range [kg]			
Piston $\varnothing$	5	7	8
Permissible mass range up to	2	5	10

# Stop elements YSRWJ

Data sheet



## Materials

Sectional view

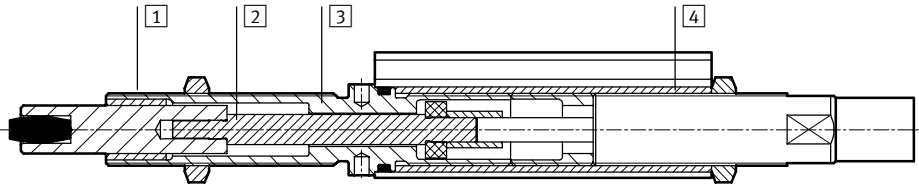

Piston Ø	5	7	8
1	Housing Brass, nickel-plated		
2	Stop bolt Steel, stainless and reinforced		
3	Distance sleeve Aluminium		
4	Threaded barrel Brass, nickel-plated		
	Material note Free of copper, PTFE and silicone		

## Selection graphs for limit stops with shock absorber YSRWJ

Impact velocity dependent on mass m

YSRWJ-5-8-A

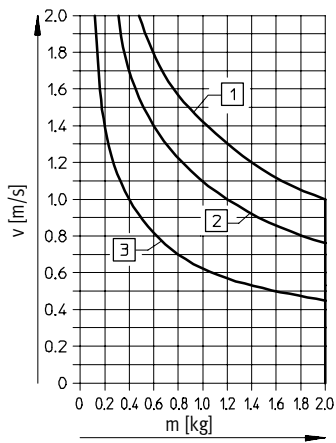

- 1 Without additional force
- 2 With additional force  $A = 50$  N
- 3 With additional force  $A = 100$  N

YSRWJ-7-10-A

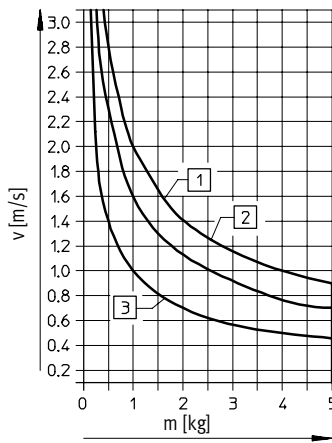

- 1 Without additional force
- 2 With additional force  $A = 75$  N
- 3 With additional force  $A = 150$  N

YSRWJ-8-14-A

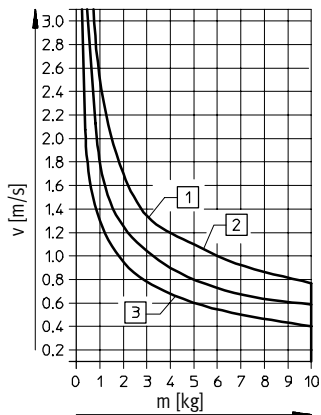

- 1 Without additional force
- 2 With additional force  $A = 100$  N
- 3 With additional force  $A = 150$  N

# Stop elements YSRWJ

Data sheet



## Mode of operation

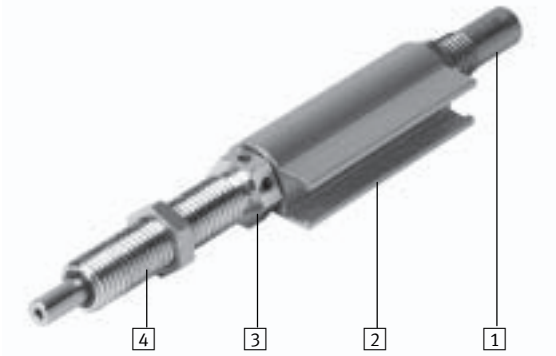

- 1 Soft cushioning characteristics – cushioning stroke is adjustable
- 2 End-position sensing via proximity sensor SME-/SMT-8 that can be integrated
- 3 Precision end-position adjustment
- 4 Precision end position thanks to internal, metallic inserts

## Dimensions

Download CAD data → [www.festo.com/en/engineering](http://www.festo.com/en/engineering)

YSR-...-C

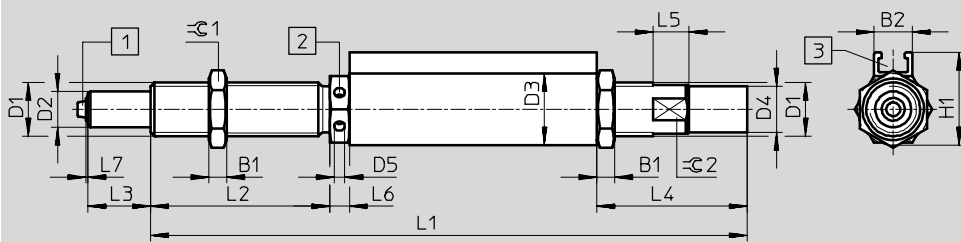

- 1 Rubber buffer, only with sizes: YSRWJ-7-10-A and YSRWJ-8-14-A
- 2 Precision end-position adjustment
- 3 Slot for proximity sensor SME-/SMT-8

∅	B1	B2	D1	D2	D3	D4	D5	H1	L1
[mm]		+0.4			+0.1		+0.1	+0.3	+0.3/-0.1
5	3	8.1	M8x1	4	12	6.7 ±0.05	2	16.5	97.4
7	3.5	8.5	M10x1	6	14	8.6 ±0.05	2.4	18.3	144.8
8	4	8.5	M12x1	8	16	10.4 ±0.1	2.4	20.75	133.3

∅	L2	L3	L4	L5	L6	L7	∅1	∅2
[mm]	+0.4		+0.45/-0.1	+0.5	+0.1/-0.55	+0.3		
5	32.5	8 ±0.7/-0.55	21.6	5	4.4	0.5	10	7
7	40	10 ±0.8/-0.55	21.1	6	4	0.5	13	9
8	40	14 ±0.8/-0.55	33.6	8	4.4	0.5	15	11

## Ordering data

∅	Part No.	Type
[mm]		
5	192 968	YSRWJ-5-8-A
7	192 967	YSRWJ-7-10-A
8	192 966	YSRWJ-8-14-A

# Hydraulic cushioning cylinder YDR

Peripherals overview and type codes

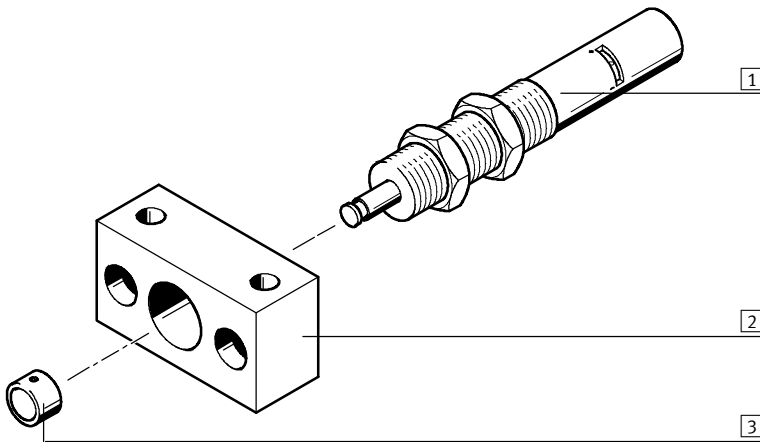

Accessories			
	Type	Brief description	→ Page
1	Hydraulic cushioning cylinders YDR	Hydraulic cushioning cylinder with reset spring for slow feed speeds	1 / 9.2-1
2	Mounting flange YSRF	Mounting option for shock absorber	1 / 9.3-0
3	Buffer YSRP	For the protection of piston rod	1 / 9.3-2
-	Oil gun YSR-OEP	For topping up oil	1 / 9.3-2
-	Special oil OFSB-1	Replacement oil	1 / 9.3-2

	YDR	-	16	-	20
<b>Type</b>					
YDR	Hydraulic cushioning cylinder				
<b>∅[mm]</b>					
<b>Stroke [mm]</b>					

# Hydraulic cushioning cylinder YDR

Data sheet

FESTO

Function

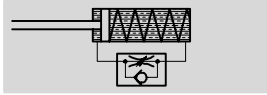

- $\varnothing$  - Diameter  
16 ... 32 mm
- | - Stroke length  
20 ... 60 mm



General technical data					
Piston $\varnothing$		16	20	25	32
Stroke	[mm]	20	25	40	60
Mode of operation	Hydraulic cushioning cylinder with return spring				
Cushioning	Adjustable				
Type of mounting	Thread with locknut				
Impact velocity, max.	[m/s]	0.3		0.4	
Min. feed speed	[mm/s]	0.2			
Max. feed speed	[mm/s]	100			
Product weight	[g]	280	460	900	1,600
Ambient temperature	[°C]	0 ... +80			

Reset times [s]					
Piston $\varnothing$		16	20	25	32
Short <sup>1)</sup>		≤ 0.4			
Long <sup>2)</sup>		≤ 1			

- 1) Piston rod retracted for short period ≤ 30 s
- 2) Piston rod retracted for longer period ≤ 6 h

Forces [N]					
Piston $\varnothing$		16	20	25	32
Min. feed force		60	70	90	120
Max. feed force <sup>1)</sup>		1,600	2,500	4,000	6,400
Resetting force		25	25	35	35

- 1) Corresponds to max. force in the end position

Energies [J]					
Piston $\varnothing$		16	20	25	32
Max. energy absorption per stroke		32	62.5	160	384
Max. energy absorption per hour		65,000	90,000	150,000	220,000
Max. residual energy		0.16	0.32	0.8	2

# Hydraulic cushioning cylinder YDR

Data sheet



## Materials

Sectional view

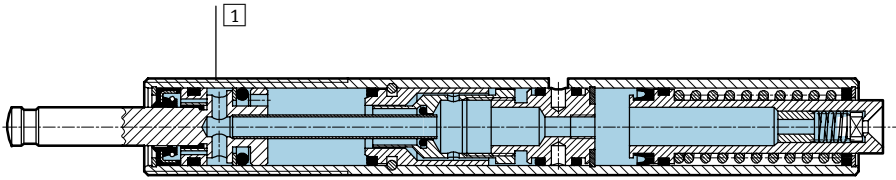

## Hydraulic cushioning cylinder

1	Housing	Galvanised steel
-	Seals	Perbunan, polyurethane

## Feed speed $v$ dependent on feed force $F$ (cushioning characteristic)

YDR-16-20

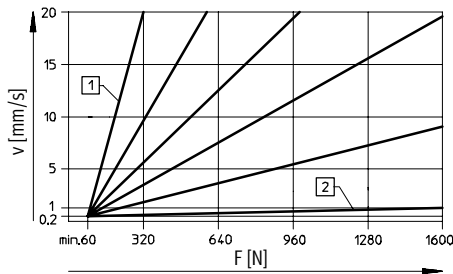

YDR-20-25

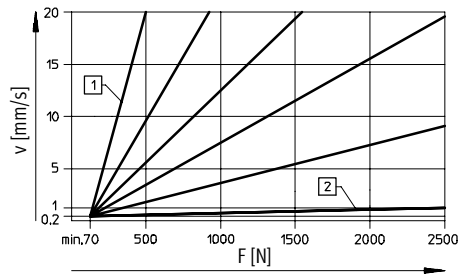

- 1 Speed adjustment open
- 2 Speed adjustment closed

YDR-25-40

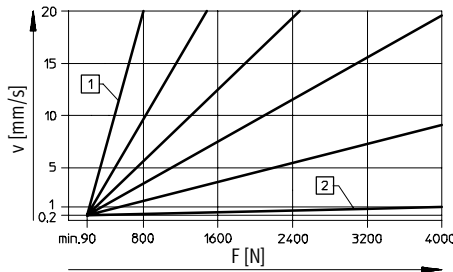

YDR-32-60

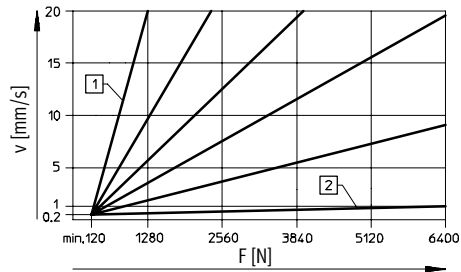

- 1 Speed adjustment open
- 2 Speed adjustment closed

# Hydraulic cushioning cylinder YDR

Data sheet

FESTO

## Dimensions

Download CAD data → [www.festo.com/en/engineering](http://www.festo.com/en/engineering)

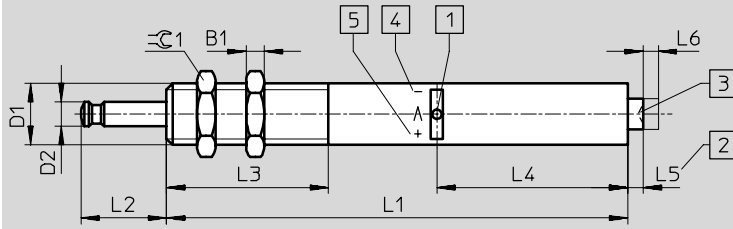

- 1 Speed control
- 2 Oil reservoir
- 3 Oil top-up  
(after 0.6 million load cycles)
- 4 - = slower speed
- 5 + = faster speed

∅	B1	D1	D2	L1	L2	L3
[mm]						
16	6	M20x1.25	8	151	28	53
20	8	M24x1.25	10	174	35	60
25	10	M30x1.5	12	227	52	80
32	12	M37x1.5	15	275	75	108

∅	L4	L5 max.	L6	≈ 1	Max. tightening torque ≈ 1
[mm]					[Nm]
16	62.5	5	5	24	35
20	72.5	6	6	30	60
25	89.8	9	10	36	80
32	106.3	13	15	46	100

## Ordering data

∅	Part No.	Type
[mm]		
16	14 900	YDR-16-20
20	14 901	YDR-20-25
25	14 902	YDR-25-40
32	14 903	YDR-32-60

# Accessories for cushioning components

Data sheet



## Mounting flange

YSRF/YSRF-C

Material:  
Steel

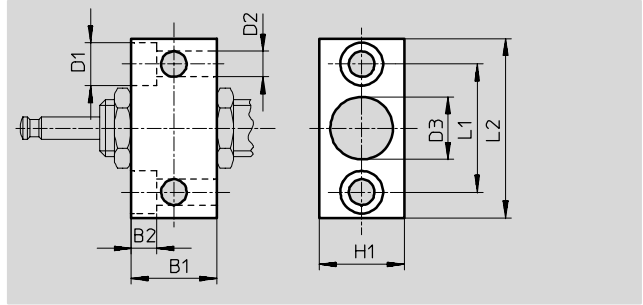
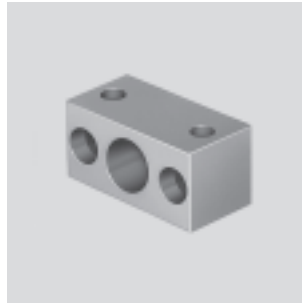

Possible combinations				
Cushioning components	YSR	YSR-C	YSRW	YDR
<b>YSRF</b>				
YSRF-8	-	■ <sup>1)</sup>	■ <sup>1)</sup>	-
YSRF-12	■	-	-	-
YSRF-16	■	-	-	■
YSRF-20	■	-	-	■
YSRF-25	■	■	-	■
YSRF-32	■	■	-	■
<b>YSRF-C</b>				
YSRF-8-C	■	■	■	-
YSRF-12-C	-	■	■	-
YSRF-16-C	-	■	■	-
YSRF-20-C	-	■	■	-

1) For shock absorber size  $\varnothing 7$

Dimensions and ordering data													
<b>YSRF</b>													
For $\varnothing$ [mm]	B1	B2	D1	D2	D3	H1	L1	L2	CRC <sup>1)</sup>	Weight [g]	Part No.	Type	
8	16	5.5	10	5.5	10.2	16	25	38	2	50	11 681	YSRF-8	
12	25	6.8	11	6.6	15.2	25	36	50	2	175	11 682	YSRF-12	
16	30	9	15	9	20.2	30	45	63	2	300	11 683	YSRF-16	
20	36	11	18	11	24.2	36	56	78	2	535	11 684	YSRF-20	
25	45	13	20	13.5	30.2	45	63	86	2	895	11 685	YSRF-25	
32	55	15	24	15.5	37.2	55	80	108	2	1,730	11 686	YSRF-32	

1) Corrosion resistance class 2 according to Festo standard 940 070

Components requiring moderate corrosion resistance. Externally visible parts with primarily decorative surface requirements which are in direct contact with a surrounding industrial atmosphere or media such as cooling or lubricating agents.

<b>YSRF-C</b>													
For $\varnothing$ [mm]	B1	B2	D1	D2	D3	H1	L1	L2	CRC <sup>1)</sup>	Weight [g]	Part No.	Type	
8	20	5.5	10	5.5	12.2	20	28	41	2	90	34 575	YSRF-8-C	
12	25	6.8	11	6.6	16.2	25	36	50	2	180	34 576	YSRF-12-C	
16	32	9	15	9	22.2	32	45	63	2	330	34 577	YSRF-16-C	
20	40	11	18	11	26.2	40	56	78	2	700	34 578	YSRF-20-C	

1) Corrosion resistance class 2 according to Festo standard 940 070

Components requiring moderate corrosion resistance. Externally visible parts with primarily decorative surface requirements which are in direct contact with a surrounding industrial atmosphere or media such as cooling or lubricating agents.



# Accessories for cushioning components

Data sheet



## Mounting flange YSRF-S-C

Material:  
Aluminium, steel  
Free of copper, PTFE and silicone

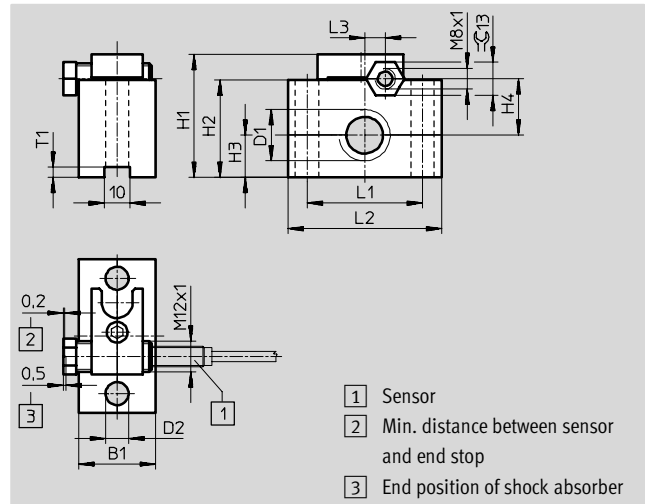
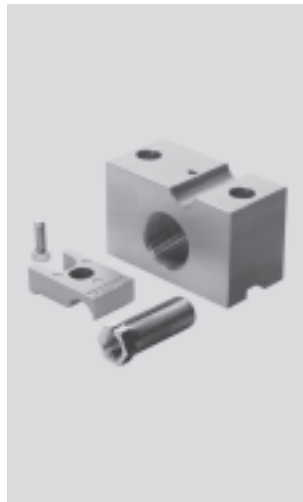

Possible combinations				
Cushioning components	YSR	YSR-C	YSRW	YDR
Mounting flange				
YSRF-S-8-C	-	■	■	-
YSRF-S-12-C	-	■	■	-
YSRF-S-16-C	-	■	■	-
YSRF-S-20-C	-	■	■	-

Dimensions and ordering data															
For Ø	B1	D1	D2 Ø	H1	H2	H3	H4	L1	L2	L3	T1	Weight [g]	Part No.	Type	
8	20	M12x1	5.5	35	25	9.5	16	32	45	4	2	12	34 579	YSRF-S-8-C	
12	25	M16x1	6.6	42	32	12.5	20	36	50	3	4	130	34 580	YSRF-S-12-C	
16	30	M22x1.5	9	48	38	16.5	22	45	60	8	4	180	34 581	YSRF-S-16-C	
20	30	M26x1.5	11	52	42	19	23.5	56	80	11.5	4	250	34 582	YSRF-S-20-C	

- - Note  
Inductive sensors for position sensing → 1 / 9.3-3

# Accessories for cushioning components

Data sheet



## Buffer YSRP

Material:  
Steel, polyurethane

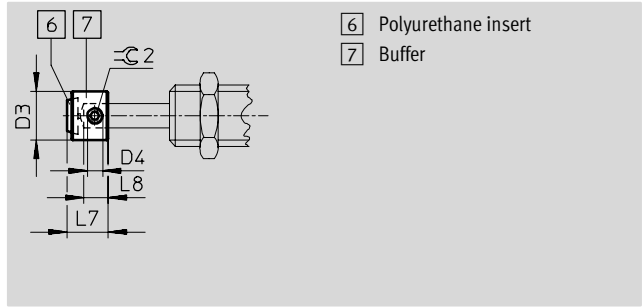

Dimensions and ordering data									
For Ø [mm]	D3	D4	L7	L8	±0.2	CRC <sup>1)</sup>	Weight [g]	Part No.	Type
8	8	M2	6,7	4	0,9	2	4	539 638	YSRP-8
12	12	M4	10	6	2	2	7	11 133	YSRP-12
16	16	M5	13.5	8	2.5	2	15	11 134	YSRP-16
20	20	M6	17	10	3	2	27	11 135	YSRP-20
25	25	M8	20.5	12	4	2	52	11 136	YSRP-25
32	32	M8	26	15	4	2	110	11 137	YSRP-32

1) Corrosion resistance class 2 according to Festo standard 940 070  
Components requiring moderate corrosion resistance. Externally visible parts with primarily decorative surface requirements which are in direct contact with a surrounding industrial atmosphere or media such as cooling or lubricating agents.

## Stop limiter YSRA-C

Material:  
Steel

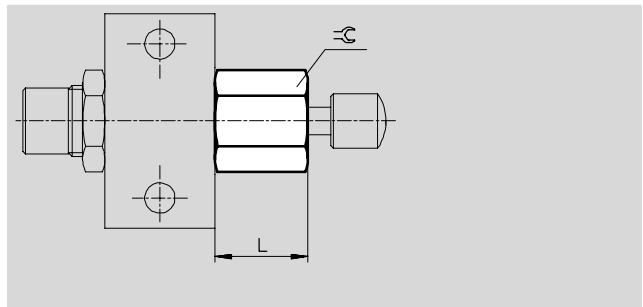

Dimensions and ordering data					
For Ø [mm]	L		±0.2	Weight [g]	Part No. Type
7	14.5		13	12	150 932 YSRA-7-C
8	18		15	28	150 933 YSRA-8-C
12	24.5		19	48	150 934 YSRA-12-C

## Oil gun YSR-OEP



## Special oil OFSB-1









Ordering data	
Part No.	Type
11 698	YSR-OEP





Ordering data	
Part No.	Type
207 873	OFSB-1



# Accessories for cushioning components

Data sheet

Ordering data – Proximity switch for slot 8, magneto-resistive, for stop elements YSRWJ							Data sheets → 1 / 10.2-13	
	Mounting	Switch output	Electrical connection			Cable length [m]	Part No.	Type
			Cables	M8 plug	M12 plug			
<b>NO contact</b>								
	Inserted from above	PNP	3 wires	–	–	2.5	525 898	SMT-8F-PS-24V-K2,5-OE
		NPN	–	–	–	–	525 909	SMT-8F-NS-24V-K2,5-OE
	Inserted from end	PNP	–	3-pin	–	0.3	525 899	SMT-8F-PS-24V-K0,3-M8D
		NPN	–	–	–	–	525 910	SMT-8F-NS-24V-K0,3-M8D
	Inserted from end	PNP	3 wires	–	–	2.5	175 436	SMT-8-PS-K-LED-24-B
		–	–	3-pin	–	0.3	175 484	SMT-8-PS-S-LED-24-B
<b>NC contact</b>								
	Inserted from above	PNP	3 wires	–	–	7.5	525 911	SMT-8F-PO-24V-K7,5-OE

Ordering data – Proximity switch for slot 8, magnetic reed, for stop elements YSRWJ							Data sheets → 1 / 10.2-16	
	Mounting	Electrical connection			Cable length [m]	Part No.	Type	
		Cables	M8 plug	M12 plug				
<b>NO contact</b>								
	Inserted from above	3 wires	–	–	2.5	525 895	SME-8F-DS-24V-K2,5-OE	
		–	3-pin	–	0.3	525 896	SME-8F-DS-24V-K0,3-M8D	
	Inserted from end	3 wires	–	–	2.5	150 855	SME-8-K-LED-24	
		–	3-pin	–	0.3	150 857	SME-8-S-LED-24	
<b>NC contact</b>								
	Inserted from above	3 wires	–	–	7.5	525 906	SME-8F-DO-24V-K7,5-OE	

Ordering data – Inductive sensors M8, for mounting flange YSRF-S-C						Data sheets → Volume 4		
	Electrical connection		Switch output	LED	Cable length [m]	Part No.	Type	
	Cable	M8 plug						
<b>NO contact</b>								
	3 wires	–	PNP	■	2.5	150 386	SIEN-M8B-PS-K-L	
	–	3-pin	PNP	■	–	150 387	SIEN-M8B-PS-S-L	
	3 wires	–	PNP	■	2.5	150 390	SIEN-M8B-PO-K-L	
	–	3-pin	PNP	■	–	150 391	SIEN-M8B-PO-S-L	
<b>NC contact</b>								
	3 wires	–	PNP	■	2.5	150 390	SIEN-M8B-PO-K-L	
	–	3-pin	PNP	■	–	150 391	SIEN-M8B-PO-S-L	

Ordering data – Plug sockets							Data sheets → 1 / 10.2-100	
	Mounting	Switch output		Connection	Cable length [m]	Part No.	Type	
		PNP	NPN					
<b>Straight plug socket</b>								
	M8 union nut	■	■	3-pin	2.5	159 420	SIM-M8-3GD-2,5-PU	
		■	■	–	5	159 421	SIM-M8-3GD-5-PU	
<b>Angled plug socket</b>								
	M8 union nut	■	■	3-pin	2.5	159 422	SIM-M8-3WD-2,5-PU	
		■	■	–	5	159 423	SIM-M8-3WD-5-PU	

 Core Range

# Calculation tool for cushioning components

Data sheet

This selection aid helps you find the right shock absorber for every application.

When you are choosing a shock absorber, we recommend that you proceed as follows:

- Determine the following values, effective at the time of impact:
  - Force (A)
  - Equivalent mass  $m_{equiv}$
  - Impact velocity (v)
- Select a shock absorber from the graphs on the following pages.
- Check your selection on the basis of its maximum cushioning energy ( $W_{max.}$ )



Selection and ordering aid  
Shock absorber  
[www.festo.com/en/engineering](http://www.festo.com/en/engineering)

When you are choosing a shock absorber for your application, ensure that the following values are not exceeded:

- Permissible energy load per stroke:
  - $W_{min.} = 25\%$
  - $W_{max.} = 100\%$
- Recommended energy load per stroke:
  - $W_{opt.} = 50\% \dots 100\%$
- Max. energy absorption per hour
- Max. residual energy
- Max. stop force in end position

The (angular) velocity required in the formulae is the velocity at the time of the impact on the shock absorber. This depends on the dynamic characteristics of the drive component and is thus difficult to determine.

In order to prevent damage to the drive concerned, calculations should in the interests of safety be based on the following values:

- $v = 1.25 \dots 2 v_m$
- $\omega = 1.25 \dots 2 \omega_m$
- Guide values for linear motions:
  - Factor 2 with strokes  $< 50$  mm,
  - factor 1.5 with strokes  $> 50$  mm and  $< 100$  mm,
  - factor 1.25 with strokes  $> 100$  mm.

The fact that the (angular) velocity appears in the calculation as a squared value means that the expected error becomes considerably larger. The calculation can thus be regarded only as an approximation.

The safety factor does, however, ensure that the selected shock absorber is not too small.

It is better to determine the mean velocity ( $v_m = s/t$  or  $\omega_m = \varphi/t$ ).

The following formulae are required for the calculation:

$$A = F + G$$

$$A = F + m \times g \times \sin \alpha$$

$$W_{total} = \frac{1}{2} \times m \times v^2 + A \times s < W_{max.}$$

$$W_h = W_{total} \times \text{Stroke} \div \text{Hours} < W_{hmax.}$$

The following applies additionally for rotary motions:

$$m_{equiv.} = \frac{J}{R^2}$$

$$v = \omega \times R$$

$$A = \frac{M}{R} + m \times g \times \sin \alpha \times \frac{a}{R}$$

The following abbreviations are used:

- |   |  |  |
|---|--|--|
| A = Additional force = F + G [N]                          | v = Impact velocity [m/s]                                | J = Mass moment of inertia [kg x m <sup>2</sup> ]              |
| F = Cylinder force minus frictional force [N]             | $m_{equiv.}$ = Equivalent mass [kg]                      | R = Distance between mass pivot point and shock absorber [m]   |
| G = Force due to weight = $m \times g \times \sin \alpha$ | g = Acceleration due to gravity 9.81 [m/s <sup>2</sup> ] | $\omega$ = Angular velocity [rad/s]                            |
|   | s = Shock absorber stroke [m]                            | M = Drive torque [Nm]  |
|   | $\alpha$ = Impact angle [°]                              | a = Distance between centre of gravity of mass and pivot point |
| Special cases:  | $W_{total}$ = Cushioning work/stroke [J]                 |  |
| $\alpha = 0^\circ$ : Horizontal motion<br>G = 0           | $W_h$ = Cushioning work/hour [J]                         |  |
| $\alpha = 90^\circ$ : Downward motion<br>G = $m \times g$ |  |  |
| $\alpha = 90^\circ$ : Upward motion:<br>G = $-m \times g$ |  |  |

# Calculation tool for cushioning components

Data sheet



## Sizing example for linear motion

This example illustrates the procedure for the selection of a shock absorber for the application shown in the adjacent drawing:

$$A = F + m \times g \times \sin \alpha$$

$$= 190 \text{ N} + 50 \times 9.81 \times \sin 45^\circ \text{ N}$$

$$= 537 \text{ N}$$

$$m_{\text{equiv}} = m = 50 \text{ kg}$$

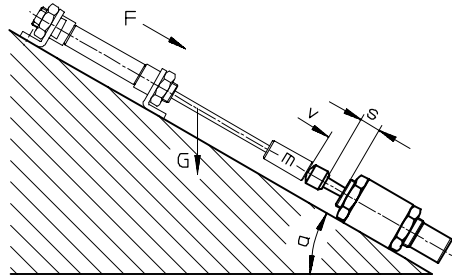

- $m = 50 \text{ kg}$
- $v = 1.5 \text{ m/s}$
- $\alpha = 45^\circ$
- $F = 190 \text{ N}$

( $\varnothing 20 \text{ mm}$  with  $p = 6 \text{ bar}$ ,  
1,800 strokes per hour)

In the process of selecting shock absorbers on the basis of the graphs (see data sheets), the force (A) is governed by the first curve to the right of the point of intersection of the equivalent mass ( $m_{\text{equiv}}$ ) and the impact velocity (v). The curves move to the left as the additional force increases.

Three force curves are given for each shock absorber. Interim values must be calculated by averaging. As the

graphs show (continuous line), possible choices are the shock absorbers YSR-25-40 and YSR-25-40-C.

We must now determine whether the maximum permissible values for cushioning work ( $W_{\text{max.}}$ ) and cushioning work per hour ( $W_{\text{hmax.}}$ ) are not being exceeded. These maximum permissible values and the stroke length (s) can be found in the tables (below the graphs).

Experiment:

$$W_{\text{total}} = \frac{1}{2} \times m \times v^2 + A \times s$$

$$= (1/2 \times 50 \times 1.5^2 + 537 \times 0.04) \text{ Nm} = 78 \text{ J}$$

$$W_{\text{h}} = W_{\text{total}} \times \text{strokes/h}$$

$$= 78 \text{ Nm} \times 1,800$$

$$= 140,000 \text{ J}$$

For the above application, both shock absorbers are suitable.

Further selection criteria are adjustment facilities and size.

Result	YSR-25-40	YSR-25-40-C
$W_{\text{total}}$	78 J	78 J
$W_{\text{h}}$	140,000 J	140,000 J
$W_{\text{max.}}^{1)}$	160 J > $W_{\text{total}}$	160 J > $W_{\text{total}}$
$W_{\text{hmax.}}$	290,000 > $W_{\text{max.}}$	150,000 > $W_{\text{max.}}$

1) The degree of utilisation is 49% in both cases.

# Calculation tool for cushioning components

Data sheet



## Sizing example for rotary motion

Example for rotary motion:

$$m_{\text{equiv}} = J/R^2 = 8 \text{ kg}$$

$$v = \omega \times R$$

$$A = M/R = 40 \text{ N}$$

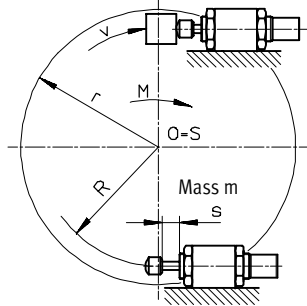

$$J = 2 \text{ kg m}^2$$

$$\omega = 4 \text{ rad/s}$$

$$R = 0.5 \text{ m}$$

$$M = 20 \text{ Nm}$$

900 strokes per hour

In the process of selecting shock absorbers on the basis of graphs (see data sheets), the force (A) is governed by the first curve to the right of the point of intersection of the equivalent mass ( $m_{\text{equiv}}$ ) and the impact velocity (v). The curves move to the left as the additional force increases.

Three force curves are given for each shock absorber. Interim values must be calculated by averaging. As the graphs show (dotted line), possible

choices are the shock absorbers YSR-16-20 and YSR-16-20-C.

We must now determine whether the maximum permissible values for cushioning work ( $W_{\text{max}}$ ) and cushioning work per hour ( $W_{\text{hmax}}$ ) are not being exceeded. These maximum permissible values and the stroke length (s) can be found in the tables (below the graphs).

Experiment:

$$W_{\text{total}} = \frac{1}{2} \times m \times v^2 + A \times s$$

$$= (1/2 \times 8 \times 2^2 + 40 \times 0.02) \text{ J} = 17 \text{ J}$$

$$W_{\text{h}} = W_{\text{total}} \times \text{strokes/h}$$

$$= 17 \text{ J} \times 900$$

$$= 15,300 \text{ J}$$

For the above application, both shock absorbers are suitable.

Further selection criteria are adjustment facilities and size.

Result	YSR-16-20	YSR-16-20-C
$W_{\text{total}}$	17 J	17 J
$W_{\text{h}}$	15,300 J	15,300 J
$W_{\text{max}}$	32 J > $W_{\text{total}}^{1)}$	30 J > $W_{\text{total}}^{2)}$
$W_{\text{hmax}}$	130,000 > $W_{\text{max}}$	64,000 > $W_{\text{max}}$

1) The degree of utilisation is 53%.

2) The degree of utilisation is 57%.