



- Modular valve terminal for a wide range of applications
- Space-saving thanks to smaller valve dimensions
- Manual override and LED switching status display
- Up to 170 l/min flow rate
- Variety of pneumatic and electrical connection options

Valve terminal type 80 CPVSC1, Smart Cubic

Key features

FESTO

Application-optimised valve terminals
Smart Cubic

3.1

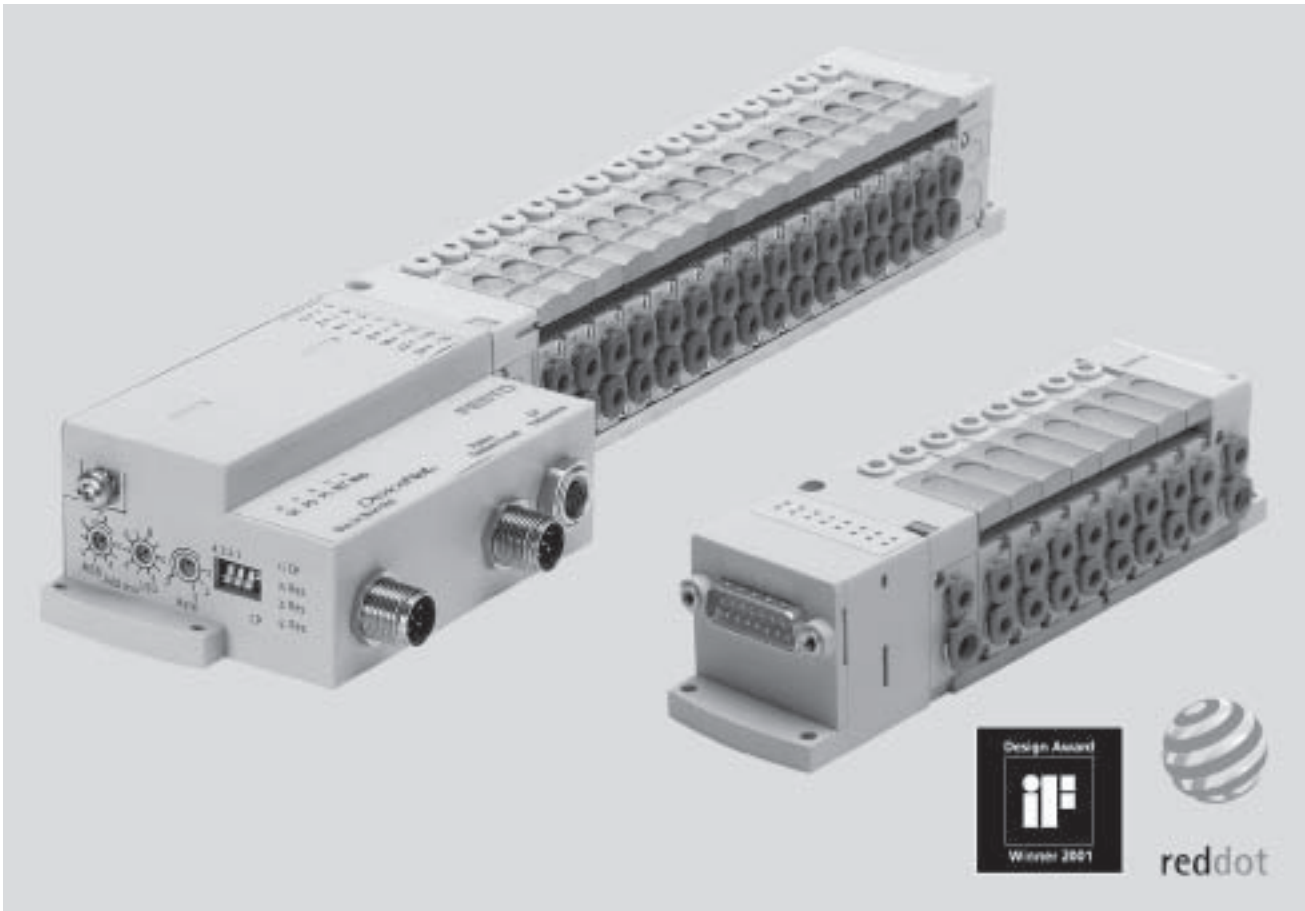

Innovative

- Small, compact valve terminal for a wide range of pneumatic applications
- Highly versatile during the planning and assembly stages as well as in operational use
- Multi-pin and fieldbus interface
- Numerous selectable valve functions; 5/2-way, 3/2-way and 2/2-way functions
- With a flow rate of 170 l/min, CPV-SC offers outstanding pneumatic performance for a wide range of applications
- Low weight

Versatile

- Provides 4 ... 16 valve positions on one terminal
- Ideally suited for operating small pneumatic drives in tight spaces
- The flexibility of the pneumatic working connections facilitates a practical solution to different requirements
- Built-in silencer or ducted exhaust air
- Suitable for vacuum
- Permits multiple pressure zones on a single valve terminal

Reliable

- Manual override facility
- Durable thanks to the use of tried-and-tested piston spool valves
- Sturdy thanks to metal housing and connecting thread
- Fast troubleshooting thanks to LEDs on the valves and diagnosis via fieldbus

Easy-to-mount

- Fully assembled and tested valve terminal
- Minimised expenditure with regard to ordering, installation and commissioning
- Direct mounting even on moving system components
- Reliable servicing

Valve terminal type 80 CPVSC1, Smart Cubic

Key features

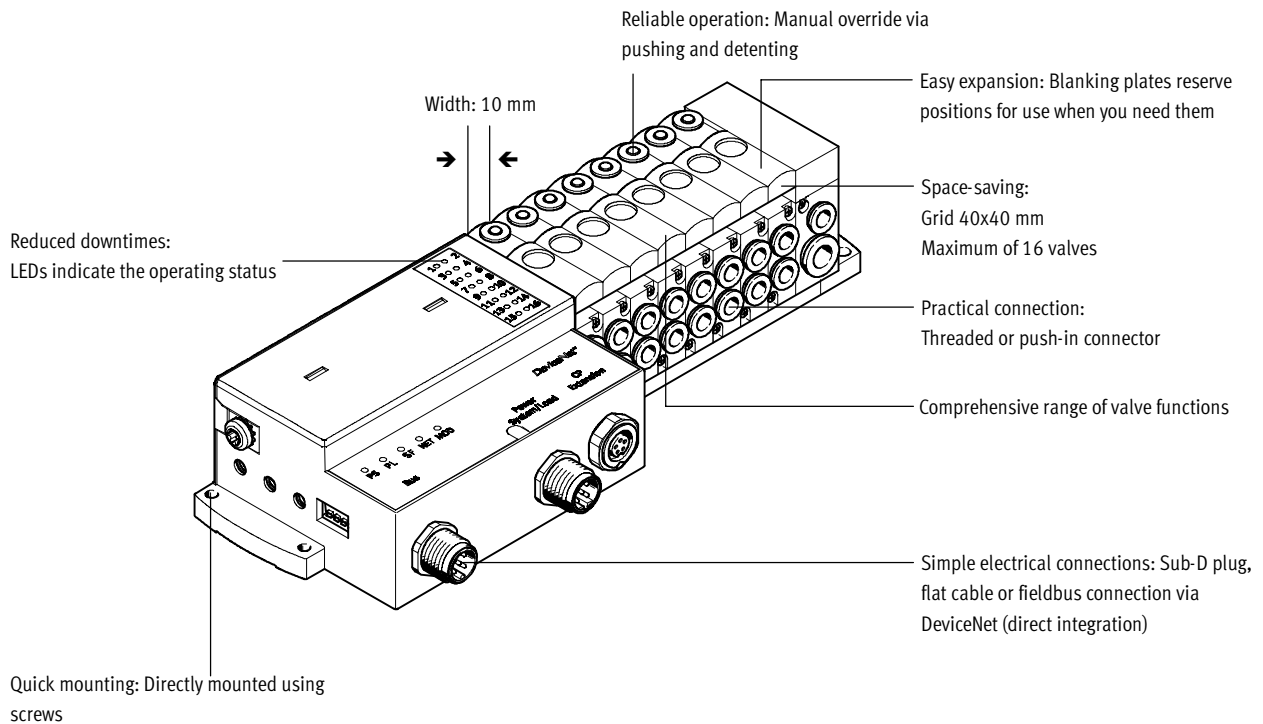

Equipment options

A CPVSC valve terminal can be equipped with the following valve functions and electrical connections:

Valve functions

- 5/2-way valve, single solenoid
- 5/2-way valve, double solenoid
- 3/2-way valve, normally open
- 3/2-way valve, normally closed
- 2/2-way valve, normally closed

Separator plate with additional compressed air supply

- Compressed air duct (1) closed
- Compressed air duct (1) and exhaust line (3/5) closed

Blanking plate

- Plate without valve function for reserving a valve position

Dimensions

All valves have the same compact dimensions with an overall length of 42 mm, a height of 40 mm and a width of 10 mm.

Electrical connection options

Multi-pin

- 4 ... 16 valve positions/max. 16 solenoid coils
- Sub-D
- Flat cable

Fieldbus

- 4 ... 16 valve positions/max. 16 solenoid coils

CP string extension

- Further valve terminals from the CPV/CPA range
- or electrical I/O modules

Valve terminal type 80 CPVSC1, Smart Cubic

Key features



Application-optimised valve terminals
Smart Cubic

3.1

Valve terminal configurator

Online via: → www.festo.com/en/engineering

A valve terminal configurator is available to help you select a suitable CPVSC valve terminal. This makes it much easier for you to find the right product.

The valve terminals are fully assembled according to your order specifications and individually tested. This reduces the amount of assembly and installation required to a minimum. You order a valve terminal type 80 using the modular order code.

Ordering system for type 80
→ 4 / 3.1-28



The illustration above provides an example of a valve terminal configuration. And this is how you arrive at the order code:

Once you have called up the Festo home page, select the online version of the digital product catalogue from the “Products” submenu: this will bring you directly to the home page for the Pneumatic Catalogue. Activate the “Product Search” menu.

Here you can specify a “Part No.” (e.g. 525675), “Type” (e.g. CPVSC1) or “Article designation” (e.g. valve terminal) to find your “Search result”. Click on the blue shopping basket to complete the selected product according to your specifications (this does not initiate an order). You will then be prompted to configure the product.

Select “Configurator”. You can then configure the valve terminal step by step (from the top down) according to your requirements. Select the “Finish” menu to continue on with the ordering process.

2D/3D CAD data

Online via: → www.festo.com/en/engineering

You can request the CAD data for a valve terminal you have configured. To do so, perform a product search for Part No. 525675 as described above. Click on this number to the right of the blue shopping basket. This brings you to the detailed view. In the menu bar

on the right-hand edge of the screen, click on “2D/3D CAD” and then on “Configurator”. Proceed with your configuration and then click on “Finish”. On the next page you can generate a 3D preview or request another data format of your choice by e-mail.

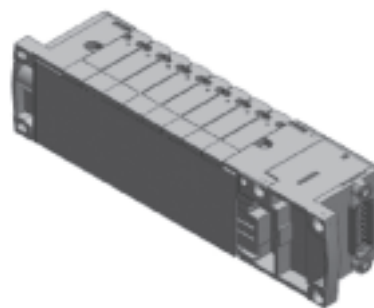

Valve terminal type 80 CPVSC1, Smart Cubic

Key features

Multi-pin plug connection

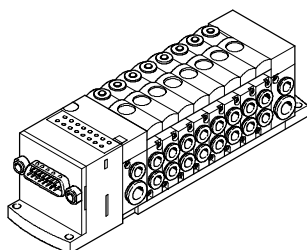

Control signals from the controller to the valve terminal are transmitted via a pre-assembled multi-core cable, which substantially reduces installation time.

These valve terminals can be fitted with 4 to 16 solenoid coils.

Variants

- Sub-D connection
- Flat cable connection

Fieldbus Direct

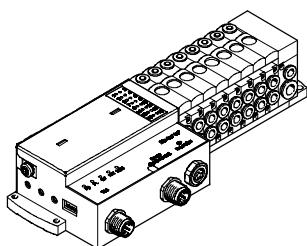

An integrated fieldbus node manages the communication connection to a higher-order PLC. This enables a space-saving pneumatic and electronic solution.

Valve terminals with fieldbus interfaces can be equipped with 4 to 16 valve positions and 4 to 16 solenoid coils.

Variants

- DeviceNet connection
- 4 to 16 solenoid coils

Valve terminal type 80 CPVSC1, Smart Cubic

Key features

CP string extension

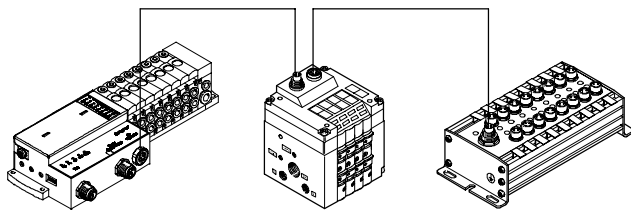

The optional string extension allows an additional valve terminal and I/O modules to be connected to the CPV Direct fieldbus node. A CP string of the CP installation system is integrated in the fieldbus node as an extension.

Different input and output modules as well as CPV and CPA valve terminals can be connected.

The max. length of the CP string extends to 10 metres, which means that the extension modules can be mounted directly on-site. All of the required electrical signals are transmitted via the CP cable, which in turn means that no further installation is needed on the extension module.

The CP string interface offers:

- 16 input signals
- 16 output signals for output modules 24 V DC or solenoid coils
- Logic and sensor supply for the input modules
- Load voltage supply for the valve terminals
- Logic supply for the output module

➔ 4 / 4.7-2

Valve terminal type 80 CPVSC1, Smart Cubic

Peripherals overview

FESTO

Valve terminal with electrical multi-pin plug connection

- 15- and 26-pin Sub-D multi-pin plug connection
Code: MS, MH

or

- 20-pin multi-pin plug connection with connector for flat cable
Code: MF

Valves and end plates are the basic pneumatic components of the valve terminal.

The valve terminals are connected to the end plates using tie rods.

Valve terminals with electrical multi-pin plug connection can be equipped with 4 to max. 16 valve positions.

Each valve position can either be equipped with a valve or a blanking plate.

The electrical connection is located on the left-hand side, thereby allowing flush mounting of the system.

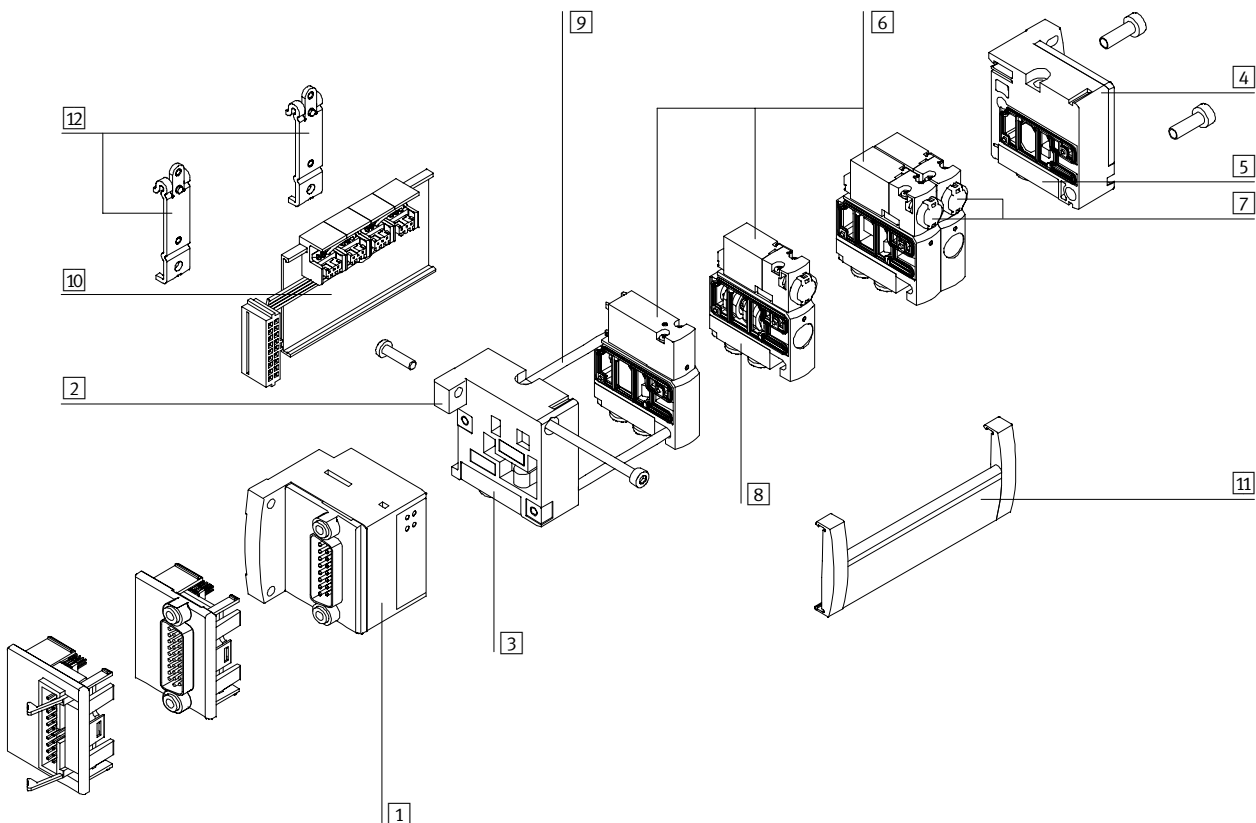

- | | | | |
|--|--|--|------------------------------------|
| 1 Electrical triggering unit for Sub-D or flat cable connection and LED switching status display | 4 Right-hand end plate for ducted exhaust air or silencer (3/5 or 82/84) | 7 Cover for manual override (optional) | 10 Valve electrical linking module |
| 2 Left-hand end plate for compressed air supply 1 or 12/14 | 5 Sub-base for ducted exhaust air (push-in fitting or thread) | 8 Sub-base for compressed air supply (push-in fitting or thread) | 11 Inscription label holder |
| 3 Connections (2, 4) underneath | 6 Valve | 9 Tie rod | 12 H-rail mounting |

Valve terminal type 80 CPVSC1, Smart Cubic

Peripherals overview



Valve terminal with Fieldbus Direct

- M12 A-coded DeviceNet connection
Code: DN

Valves and end plates are the basic pneumatic components of the valve terminal.
The valve terminals are connected to the end plates using tie rods.

Valve terminals with Fieldbus Direct DeviceNet can be equipped with 4 to max. 16 valve positions. Each valve position can either be equipped with a valve or a blanking plate.

The space-saving electrical connection is optimised for minimum tubing.

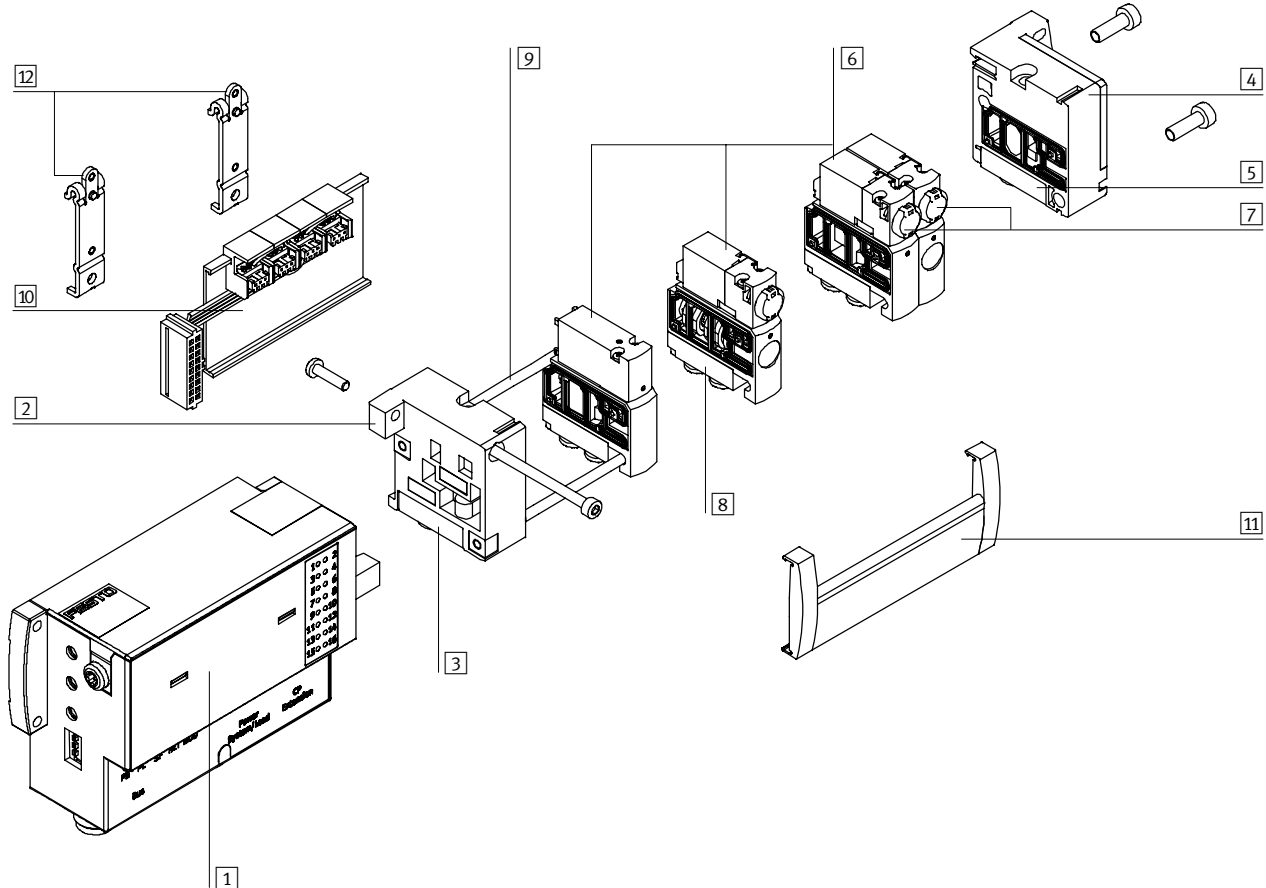

- | | | | |
|--|--|--|------------------------------------|
| 1 Fieldbus Direct | 4 Right-hand end plate for ducted exhaust air or silencer (3/5 or 82/84) | 7 Cover for manual override (optional) | 10 Valve electrical linking module |
| 2 Left-hand end plate for compressed air supply 1 or 12/14 | 5 Sub-base for ducted exhaust air (push-in fitting or thread) | 8 Sub-base for compressed air supply (push-in fitting or thread) | 11 Inscription label holder |
| 3 Connections (2, 4) underneath | 6 Valve | 9 Tie rod | 12 H-rail mounting |

Application-optimised valve terminals
Smart Cubic

3.1

Valve terminal type 80 CPVSC1, Smart Cubic



Key features – Pneumatic components

Valves

CPVSC valves are series manifold valves, i.e. in addition to the valve function they contain all of the ducts for supply, exhaust and the working

ports. The supply ducts are a central part of the valve slices and allow a direct flow of air through them. This helps achieve maximum flow rates. All

valves have a pneumatic pilot control for optimising performance. The valve function is based on a piston spool system with a patented sealing prin-

ciple that guarantees its suitability for a wide range of applications as well as a long service life.

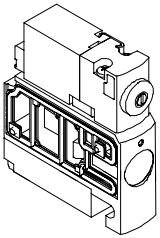
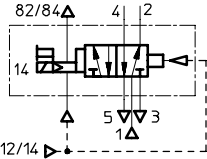
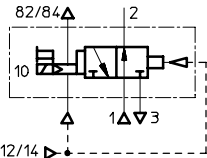
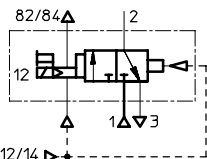
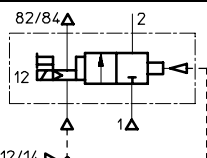
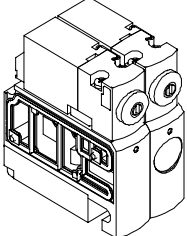
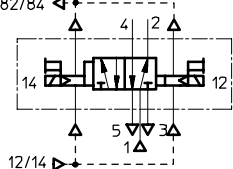
Valve functions	Code	Circuit symbol	Size 10	Description
	M		■	5/2-way valve, single solenoid Pneumatic spring return
	N		■	3/2-way valve, single solenoid Normally open Pneumatic spring return
	K		■	3/2-way valve, single solenoid Normally closed Pneumatic spring return
	D		■	2/2-way valve, single solenoid Normally closed Pneumatic spring return
	J		■	5/2-way valve, double solenoid This valve consists of two valve housing units and therefore occupies two valve positions. The pilot control with coil 12 is located on the left and labelled "J12". If both coils are actuated, the signal at port "14" dominates in switching position.

Valve terminal type 80 CPVSC1, Smart Cubic

Key features – Pneumatic components



Application-optimised valve terminals
Smart Cubic

3.1

Valves				
Valve functions	Code	Circuit symbol	Size 10	Description
Pneumatic supply plate with duct separation				
<p>3 12/14 1 82/84 5</p>	T	<p>82/84 3 5 12/14 1 2 4</p>	■	Compressed air duct (1) closed For separating pressure zones with a common exhaust. (Using pressure zones → 4 / 3.1-14) Pneumatic connection: QS-4, M5
<p>3 12/14 1 82/84 5</p>	S	<p>82/84 3 5 12/14 1 2 4</p>	■	Compressed air duct (1) and exhaust line (3/5) closed For separating pressure zones with a separate exhaust. (Using pressure zones → 4 / 3.1-14) Pneumatic connection: QS-4, M5
Pneumatic supply plate without duct separation				
<p>3 12/14 1 82/84 5</p>	U	<p>82/84 3 5 12/14 1 2 4</p>	■	Additional compressed air supply (1) and additional exhaust (3/5). Pneumatic connection: QS-4, M5
Blanking plate				
<p>3 12/14 1 82/84 5</p>	L	<p>82/84 3 5 12/14 1</p>	■	Plate without valve function for reserving a valve position No pneumatic connection

In the case of compressed air supply configuration code S or T (exhaust via large surface area silencer), a plug-in silencer UC-QS-4H is included with supply plates.

Valve terminal type 80 CPVSC1, Smart Cubic

Key features – Pneumatic components

Design

Valve replacement

Valves can be replaced quickly and easily in just a few movements. Separating seals between the valves are based on a metal support and are secured in place.

Materials

The valve housing and thread in the sub-bases are made of metal, while other housing sections are made from robust plastic materials.

Extension

Valves can be ordered as accessories and are available with fully assembled sub-bases with QS or threaded connections. The functionality of the valve terminal can therefore be extended by replacing vacant positions.

For ordering purposes, valves have the valve code printed on the front and the product type on the rear.

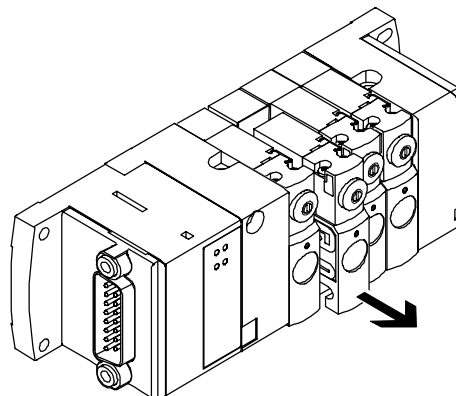

-  - Note

The valve with the working line plate has been tested by Festo for leak tightness.

Valve terminal type 80 CPVSC1, Smart Cubic

Key features – Pneumatic components



Application-optimised valve terminals
Smart Cubic

3.1

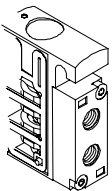
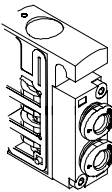
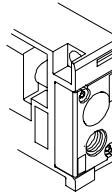
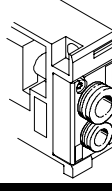
Pneumatic working lines		
	Code	Description
Working port		
	B	M5 threaded connection
	E	QS-3 push-in fitting
	F	QS-4 push-in fitting
Supply port		
	C	Threaded connection <ul style="list-style-type: none"> ■ M7 ■ M5 and M7
	G	Push-in fitting <ul style="list-style-type: none"> ■ QS-6 ■ QS-4 and QS-6

Pneumatic working lines

Supply and exhaust

A basic feature of a CPVSC valve terminal are the two end plates.

The left-hand end plate is used for the supply of compressed air, while the right-hand end plate is used to exhaust the valve terminal.

Exhaust air escapes either via an integrated large surface area silencer or via a push-in or threaded connection.

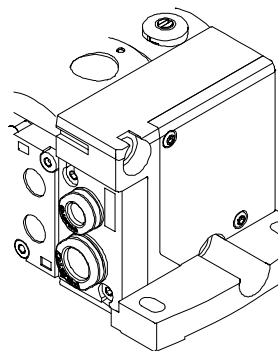
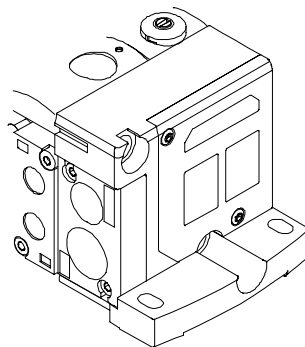

Exhaust from duct 3/5 as well as 82/84 via large surface area silencer
 Ducted exhaust air from duct 3/5 or 82/84
 Replacement part (insert) for large surface area silencer type CPVSC1-UA

Valve terminal type 80 CPVSC1, Smart Cubic

Key features – Pneumatic components



Pneumatic supply		
End plate combination	Code	Description
	S	Internal pilot air supply, large surface area silencer For operating pressure in the range 3 ... 7 bar
	T	Internal pilot air supply, large surface area silencer For operating pressure in the range -0.9 ... +7 bar
	V	Internal pilot air supply, ducted exhaust air For operating pressure in the range 3 ... 7 bar
	X	External pilot air supply, ducted exhaust air For operating pressure in the range -0.9 ... +7 bar

1) 8 bar upon request

Pilot supply air

The CPVSC valve terminal is suitable for internal or external pilot supply air, depending on the mounted end plates

Internal pilot supply air

If the supply pressure for your CPVSC valve terminal is between 3 and 7¹⁾ bar, it can be operated with internally distributed pilot air supply. Pilot air supply is branched at the left-hand end plate of port 1 for this purpose.

External pilot supply air

If the supply pressure for your CPVSC valve is between -0.9 and 3 bar, it must be operated with external pilot air. The pilot air supply is supplied externally via port 12/14 in this case.

Valve terminal type 80 CPVSC1, Smart Cubic

Key features – Pneumatic components



Using pressure zones

The CPVSC valve terminal can be operated with multiple pressure zones. After two zones, a supply with duct separation is required for each subsequent pressure zone. It always occupies one valve position. An isolating disc T separates the compressed air

supply of a valve group on the left from the compressed air supply of a valve group on the right. The right-hand pressure zone is supplied at port 4 of the supply plate. Port 2 also allows the left-hand pressure zone to

be exhausted. All of the exhaust ducts of the valve are interconnected and are exhausted through the right-hand end plate. An isolating disc S also separates exhaust lines 3 and 5 in addition to pressure duct 1.

- Note

Larger or simultaneously operating cylinders generate a back pressure in the exhaust duct of the valve terminal, the size of which depends on the exhaust capacity of the silencer. In order to prevent interaction with adjacent valves, valves can be separ-

ated by means of duct separation using isolating disc S. The pressure zone located to the left of an isolating disc S is exhausted using the supplied plug-in silencer. Where there are more than two valves in such a pressure zone, an additional supply

with additional exhaust may be required. It is therefore useful to meet the increased exhaust requirements in the pressure zone that is exhausted by the right-hand end plate.

Pneumatic supply plate

	Code	Description
	S	Duct 1/3/5 closed
	T	Duct 1 closed

Valve terminal type 80 CPVSC1, Smart Cubic

Key features – Electrical components



Electrical power as a result of current reduction

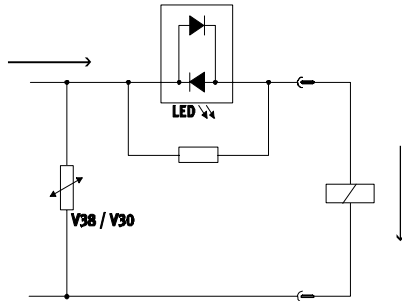

Each valve solenoid coil is protected with a spark arresting protective circuit as well as against polarity reversal.

Electrical multi-pin plug connection

The following multi-pin plug connection types are offered for the valve terminal CPVSC:

- Sub-D multi-pin plug connection (15- and 26-pin) or
- Multi-pin plug connection with connector for flat cable (20-pin)

CPVSC is connected via a multi-pin plug connection with Sub-D or flat cable. A maximum of one valve position – and therefore one coil or one address – is assigned to each pin of the multi-pin plug.

Double solenoid valves “J” occupy two valve positions. The left-hand valve position with pilot control 12 is actuated by the less significant address of the two addresses.

Electrical multi-pin plug connection – Sub-D

Code MS, MH

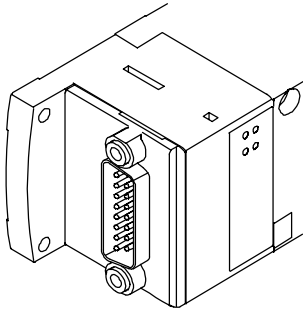

With this electrical connection variant, all valves are centrally actuated via the 15- and 26-pin connector plug. The electrical connection is located on the left-hand side.

Ordering data – Connecting cable Sub-D

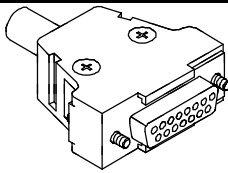
	Code	Description	Type	Part No.	
	CP	15-pin for 12 coils (code MS)	2.5 m long	KMP6-15P-12-2,5	527 543
	CQ	Material: PVC	5 m long	KMP6-15P-12-5	527 544
	CR	Suitable for chain link trunking	10 m long	KMP6-15P-12-10	527 545
	CP	26-pin for 16 coils (code MH)	2.5 m long	KMP6-26P-16-2,5	527 546
	CQ	Material: PVC	5 m long	KMP6-26P-16-5	527 547
	CR	Suitable for chain link trunking	10 m long	KMP6-26P-16-10	527 548

Valve terminal type 80 CPVSC1, Smart Cubic

Key features – Electrical components

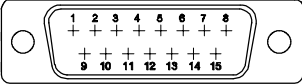

3.1

Pin allocation for 15-pin Sub-D (code MS)				
KMP6-15P-12-...	Description	Pin	Core colour	Allocation
	CPVSC valve terminal with up to 12 valve positions and multi-pin cable with 15-pin Sub-D plug	1	white	Coil 0
		2	brown	Coil 1
		3	green	Coil 2
		4	yellow	Coil 3
		5	grey	Coil 4
		6	pink	Coil 5
		7	blue	Coil 6
		8	red	Coil 7
		9	black	Coil 8
		10	purple	Coil 9
		11	grey-pink	Coil 10
		12	red-blue	Coil 11
		13	white-green	n.c.
		14	brown-green	0 V ¹⁾
		15	white-yellow	0 V ¹⁾

- 1) Pin 14 to Pin 15 are bridged in the valve terminal.
0 V for positive switching control signals; 24 V can be connected for negative switching control signals

Pin allocation for 26-pin Sub-D (code MH)				
KMP6-26P-16-...	Description	Pin	Core colour	Allocation
	CPVSC valve terminal with 16 valve positions and multi-pin cable with 26-pin Sub-D plug	1	white	Coil 0
		2	brown	Coil 1
		3	green	Coil 2
		4	yellow	Coil 3
		5	grey	Coil 4
		6	pink	Coil 5
		7	blue	Coil 6
		8	red	Coil 7
		9	black	Coil 8
		10	purple	Coil 9
		11	grey-pink	Coil 10
		12	red-blue	Coil 11
		13	white-green	Coil 12
		14	brown-green	Coil 13
		15	white-yellow	Coil 14
		16		Coil 15
		17		Coil 16
		18		n.c.
		19		n.c.
		20		0 V ¹⁾
		21		0 V ¹⁾
		22		0 V ¹⁾
		23	white-grey	0 V ¹⁾
		24	grey-brown	0 V ¹⁾
		25	white-pink	0 V ¹⁾
		26	pink-brown	0 V ¹⁾

- 1) Pin 17 to Pin 22 are bridged in the valve terminal.
0 V for positive switching control signals; 24 V can be connected for negative switching control signals

Valve terminal type 80 CPVSC1, Smart Cubic

Key features – Electrical components



Electrical multi-pin plug connection – Connector for flat ribbon cable

Code MF

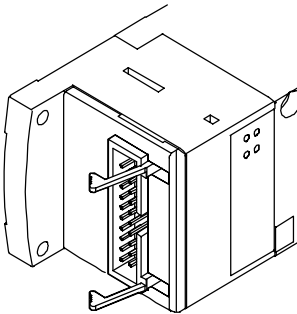

With this electrical connection variant, all valves are centrally actuated via the 20-pin connector plug. The electrical connection is located on the left-hand side.

Pin allocation – Connector for flat ribbon cable (code MF)

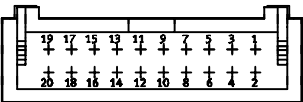
	Pin	Allocation
 <p>CPVSC valve terminal with up to 16 valve positions and 20-pin multi-pin socket for flat ribbon cables to DIN 41 561-1, -2 or IEC 60603-13-C020FD-7C1E-2G</p> <p>Contact surface gold Flat ribbon cable grid 1.27 mm Conductor cross section 0.13 mm²</p>	1	Coil 0
	2	Coil 1
	3	Coil 2
	4	Coil 3
	5	Coil 4
	6	Coil 5
	7	Coil 6
	8	Coil 7
	9	Coil 8
	10	Coil 9
	11	Coil 10
	12	Coil 11
	13	Coil 12
	14	Coil 13
	15	Coil 14
	16	Coil 15
	17	0 V ¹⁾
	18	0 V ¹⁾
	19	0 V ¹⁾
	20	0 V ¹⁾

1) Pin 17 to Pin 20 are bridged in the valve terminal.

Valve terminal type 80 CPVSC1, Smart Cubic

Key features – Electrical components

Fieldbus Direct

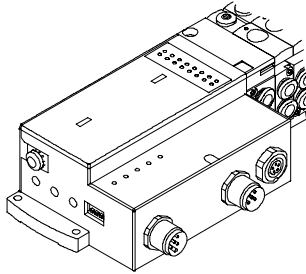

Fieldbus Direct is a system for the compact connection of a valve terminal of various sizes to different fieldbus standards.

The CP string extension option allows the functions and components of the CP installation system to be used.

The I/O modules and cables for the CP string extension are ordered using the order code for the CP installation system.

➔ 4 / 4.6-2

Address allocation – Solenoid coils

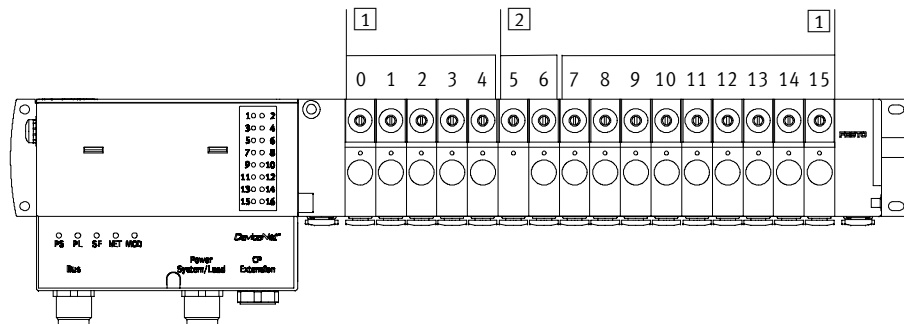

Example:

Valve terminal where valve positions 5 and 6 are prepared for 2 solenoids.

- 1 Single solenoid valves occupy one valve position
- 2 Double solenoid valves occupy two valve positions

The addresses of the valve positions on the CPV-SC-DN are assigned from left to right. Each valve position has an address, regardless of whether or not a valve is mounted there.

Double solenoid valves “J” occupy two valve positions. The left-hand valve position with pilot control 12 is actuated by the less significant address of the two addresses.

Valve terminal type 80 CPVSC1, Smart Cubic

Key features – Display and operation



Display and operation

The switching status of every solenoid coil is displayed on the triggering unit LED. Inscription labels (type MH-BZ-80x) can be applied to each valve for labelling purposes.

The manual override (MO) allows the valve to be switched when in the electrically non-activated or de-energised status. The valve is switched by pushing the manual override. The set switching status can also be secured by rotating the manual override.

A cover can be fitted over the manual override to prevent it from being actuated accidentally (code V).



Note

A manually actuated valve (manual override) cannot be reset electrically. Conversely, an electrically actuated valve cannot be reset using the mechanical manual override.

Manual override

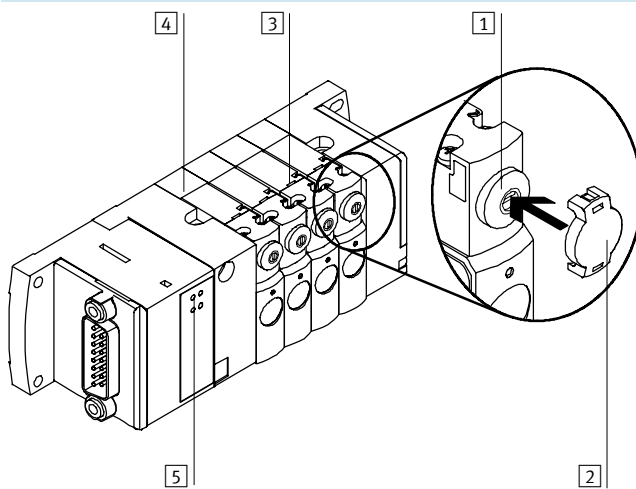

- 1 Manual override (pushing and detenting via turning using a screwdriver)
- 2 Cover for manual override (code V or accessory CPVSC1-HV)
- 3 Location for valve position inscription label (type MH-BZ-80x)
- 4 Numbering of valve positions
- 5 LED signal status display per valve position

Manual override with automatic return (push-in)

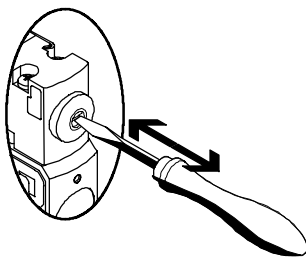

MO is actuated by pushing it with a pin or screwdriver and reset by spring force.

Manual override with lock (detenting)

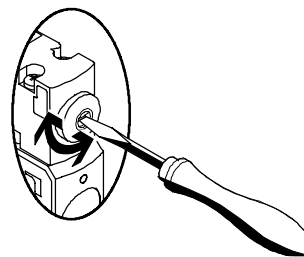

MO remains active until it is reset with a screwdriver.

Valve terminal type 80 CPVSC1, Smart Cubic

Key features – Display and operation



Display and operation

Fieldbus Direct

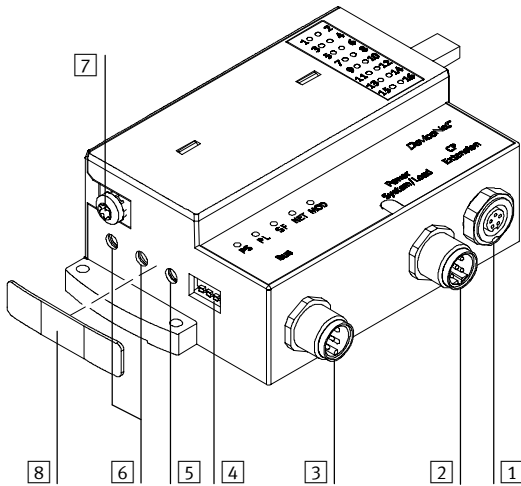

- 1 Connection for CP extension
- 2 Connection for voltage supply
- 3 Connection for fieldbus
- 4 DIL switch for CP extension
- 5 Rotary switch for baud rate
- 6 Rotary switch for station number
- 7 Earth terminal
- 8 Cover (for IP40)

Inscription label holder

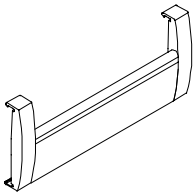

The transparent inscription label holder provides sufficient space for individually created labels on paper or foil.

Labelling templates:
www.festo.com/Services & Support/Download Area under the search term "Inscription label holders".

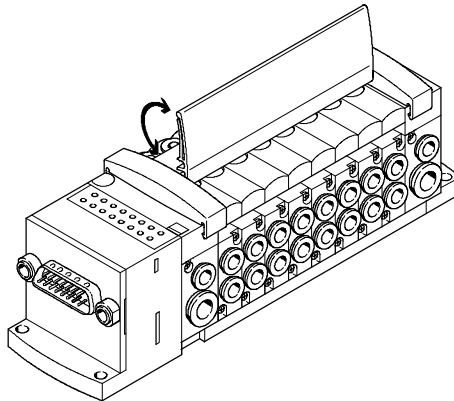

Valve terminal type 80 CPVSC1, Smart Cubic

Key features – Mounting types

Mounting – Valve terminal

Sturdy terminal attachment thanks to:

- Four through-holes for wall mounting
- H-rail mounting

Wall mounting

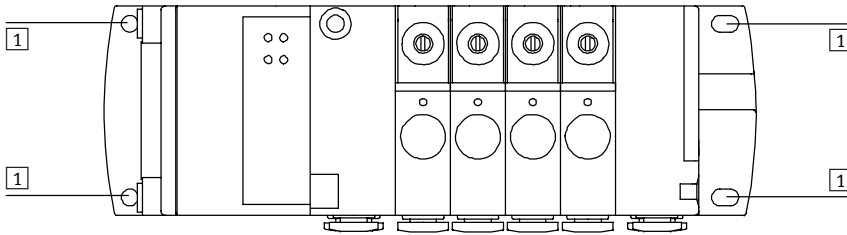

1 Mounting holes for screws M3

H-rail mounting

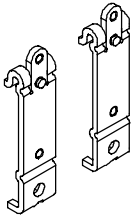

The mounting CPVSC1-HS35 facilitates mounting on the H-rail to DIN EN 50 022.

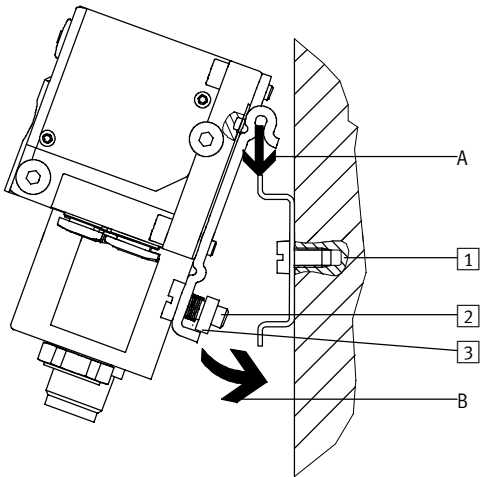

The CPVSC valve terminal is attached to the H-rail (see arrow A). It is then hinged on the H-rail and secured in place with the clamping component (see arrow B).

- 1 Holes for wall mounting
- 2 Self-tapping M4x10 screw of the H-rail clamping unit
- 3 Clamping component of the H-rail clamping unit

Valve terminal type 80 CPVSC1, Smart Cubic

Technical data



-  - Flow rate
170 l/min

-  - Valve width
10 mm

-  - Voltage
24 V DC



Application-optimised valve terminals
Smart Cubic

3.1

General technical data					
Valve	5/2-way valve		3/2-way valve		2/2-way valve
	Single solenoid	Double solenoid	Normally open	Normally closed	Normally closed
Valve function ordering code	M	J	N	K	D
Design	Electromagnetically actuated piston spool valve				
Width [mm]	10		10		10
Nominal size [mm]	2.5		2.5		2.5
Standard nominal flow rate [l/min]	170		170		150
Lubrication	Lubricated for life				
Type of mounting	Wall mounting				
Assembly position	Any				
Manual override	Push-in/detenting/covered				
Pneumatic connections					
Supply	1	M7, QS-6			
Exhaust port	3/5	M7, QS-6 or integrated large surface area silencer			
Working ports	2/4	Depending on the connection type selected <ul style="list-style-type: none"> ■ M5 ■ QS-3 ■ QS-4 			
Pilot air port	12/14	M5, QS-4			
Pilot exhaust air port	82/84	M5, QS-4 or integrated large surface area silencer			

Valve terminal type 80 CPVSC1, Smart Cubic

Technical data

Operating pressure [bar]	
Valve function ordering code	M J N K D
Without pilot air supply	3 ... 7
With pilot air supply	-0.9 ... +7
Pilot pressure	3 ... 7

Pilot pressure p2 as a function of operating pressure p1

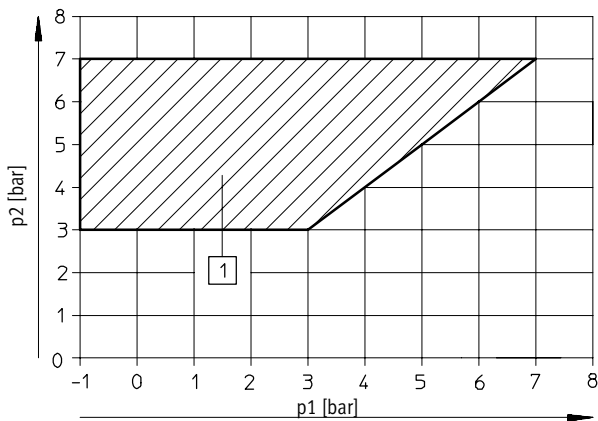

1 Operating range for valves with external auxiliary pilot air

Valve response times [ms]						
Valve function ordering code	M J N K D					
Response times	on	10	10	10	10	10
	off	10	-	10	10	10
	change-over	-	6	-	-	-

Operating and environmental conditions	
Valve function ordering code	M J N K D
Operating medium	Filtered compressed air, lubricated or unlubricated, inert gases permissible → 4 / 3.1-25
Grade of filtration [µm]	40 (average pore size)
PWIS-free	Yes (free of paint wetting impairment substances)
CE symbol	Yes, with control unit to EMC regulations
Ambient temperature [°C]	-5 ... +40
Temperature of medium [°C]	0 ... +40
Storage temperature [°C]	-20 ... +40
Corrosion resistance class CRC ¹⁾	1

1) Corrosion resistance class 1 according to Festo standard 940 070
 Components requiring low corrosion resistance. Transport and storage protection. Parts that do not have primarily decorative surface requirements, e.g. in internal areas that are not visible or behind covers.

Valve terminal type 80 CPVSC1, Smart Cubic

Technical data



Application-optimised valve terminals
Smart Cubic

3.1

Electrical data	
Valve function ordering code	M J N K D
Electromagnetic compatibility of the CPVSC valve terminal (Sub-D or flat cable connection)	Interference emission tested to EN 50 081-2, industry
	Interference immunity ¹⁾ tested to EN 61 000-6-2, industry
Protection against electric shock (protection against direct and indirect contact to EN 60204-1/IEC 204)	By means of PELV power supply unit
Nominal operating voltage [V]	24 DC
Operating voltage range [V]	20.4 ... 26.4 DC
Electrical power consumption [W]	1.0
Duty cycle	100% at 40°C ambient temperature
Protection class to EN 60 529	IP40 (in assembled state and with detenting plug)
Relative air humidity	90% at 40°C, non-condensing
Vibration resistance	To DIN/IEC 68/EN 60 068, Parts 2-6
Continuous shock resistance	To DIN/IEC 68/EN 60 068, Parts 2-27

1) The maximum signal line length is 10 m

Materials	
Valve function ordering code	M J N K D
Electrical interface	Polymer
End plate, electrical sub-base	Polymer
Seals	Elastomer
Valve sub-base	Die-cast aluminium
Working connection plates	Polyamide

Product weight [g]	
Valve function ordering code	M J N K D
5/2-way, 3/2-way valve	30.5
5/2-way double solenoid valve	56.5
Vacant position	22.5
Right-hand end plate	42.5
Left-hand end plate	28
Controller housing	43
Tie rod, 16-fold	29.6
Electrical linking module, 16-fold	64

Valve terminal type 80 CPVSC1, Smart Cubic

Technical data

FESTO

Pneumatic equipment

Operate your equipment with unlubricated compressed air if possible. Festo valves and cylinders are designed for operation under normal use without any additional lubrication, yet still have a long service life. The quality of compressed air downstream from the compressor must correspond to that of unlubricated compressed air. If possible, do not operate all of your equipment with lubricated compressed air. The lubricators should, where possible, always be installed directly upstream of the cylinders used.

Incorrect additional oil and too high an oil content in the compressed air reduces the service life of a valve terminal. Use Festo special oil OFSW-32 or the alternatives listed in the Festo catalogue (as specified in DIN 51 524-HLP32, basic oil viscosity 32 CST at 40°C).

Bio-oils

When using bio-oils (oils which are based upon synthetic or native ester, e.g. rapeseed oil methyl ester), the maximum residual oil content of 0.1 mg/m³ must not be exceeded (see ISO 8573-1 Class 2).

Mineral oils

When using mineral oils (e.g. HLP oils to DIN 51 524, parts 1 to 3) or similar oils based on poly-alpha-olefins (PAO), the maximum residual oil content of 5 mg/m³ must not be exceeded (see ISO 8573-1 Class 4). A higher residual oil content irrespective of the compressor oil cannot be permitted, as the basic lubricant would be flushed out over time.

Valve terminal type 80 CPVSC1, Smart Cubic

Technical data



Application-optimised valve terminals
Smart Cubic
3.1

Dimensions – Valve terminal With multi-pin plug connection

Download CAD data → www.festo.com/en/engineering

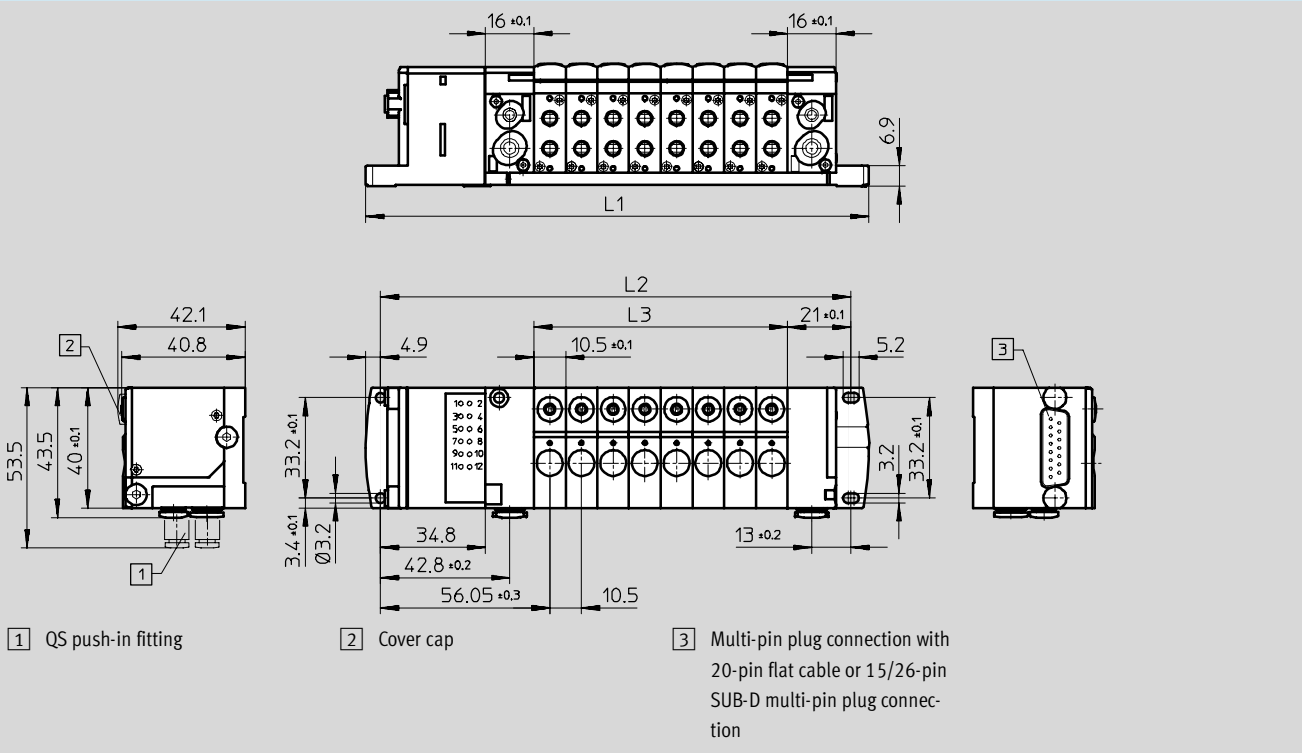

Valve positions n	L1	L2	L3
4	125 +0.8/-4	114 +0.5/-0.5	42 +0.4
8	167 +1.2/-1.4	156 +0.9/-0.5	84 +0.8
12	209 +1.6/-1.4	198 +1.3/-0.5	126 +1.2
16	251 +2.0/-1.4	240 +1.7/-0.5	168 +1.6

Dimensions – Sub-D plug with cable

Download CAD data → www.festo.com/en/engineering

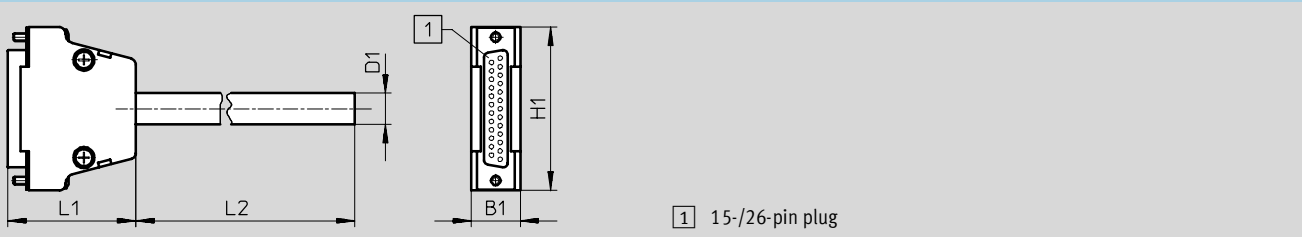

Type	B1	D1	H1	L1	L2			Number of pins
KMP6-15P-12-...	16	8.5	40	34.5	2500	5000	10000	15
KMP6-26P-16-...	16	8.6	40	34.5	2500	5000	10000	26

Valve terminal type 80 CPVSC1, Smart Cubic

Technical data



Dimensions – Valve terminal

Download CAD data → www.festo.com/en/engineering

With fieldbus connection

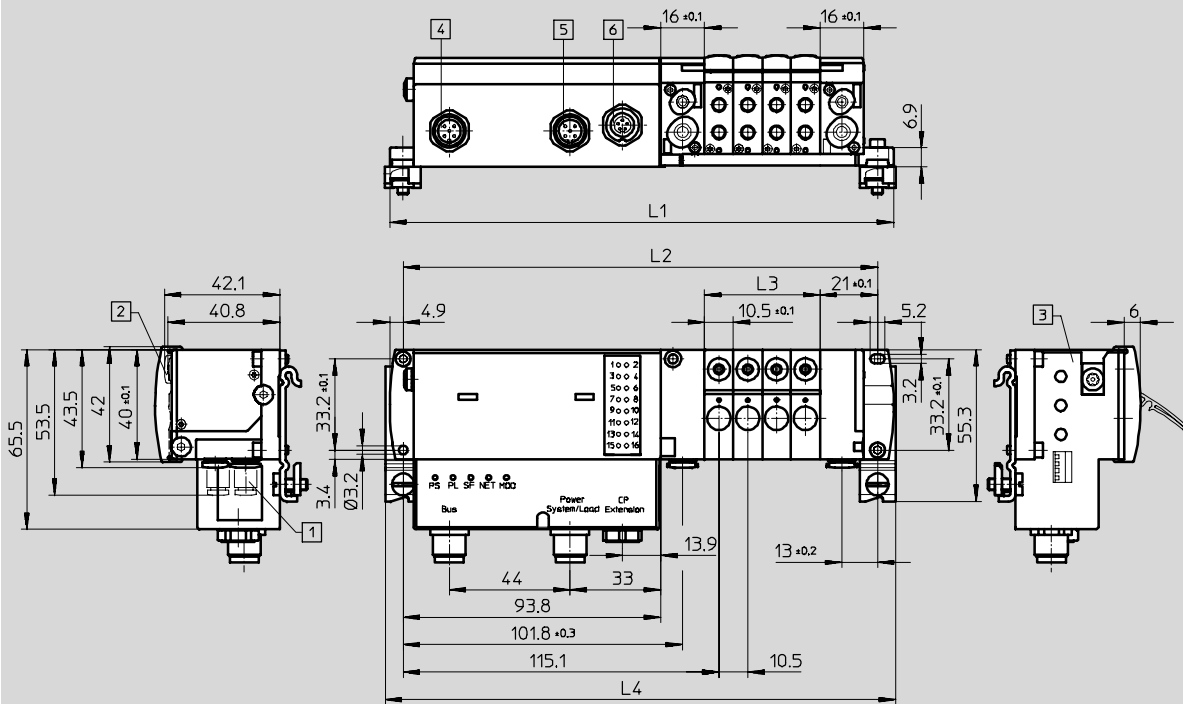

- 1 QS push-in fitting
- 2 Cover cap
- 3 Fieldbus connection DN
- 4 Bus connection M12
- 5 Voltage supply M12
- 6 CP connection M9

Valve positions n	L1	L2	L3	L4
4	183.6 +0.8/-1.4	172.8 +0.5/-0.5	42 +0.4	185.4
8	225.8 +1.2/-1.4	214.8 +0.9/-0.5	84 +0.8	227.4
12	267.6 +1.6/-1.4	256.8 +1.3/-0.5	126 +1.2	269.4
16	309.6 +2.0/-1.4	298.8 +1.7/-0.5	168 +1.6	311.4

Valve terminal type 80 CPVSC1, Smart Cubic – Multi-pin

Ordering data – Modular products



M Mandatory data →

Module No.	Valve terminal	Size	Power supply	Electrical connection	Position of working ports	Pneumatic working ports	Manual override	Pneumatic supply	Pneumatic supply connection	Type of connections
525 675	80P	10	1 5	MS MF MH	P	B E F	N V	S T V X	L	C G
Ordering example										
529 675	80P	10			P				L	
1	2	3	4	5	6	7	8	9	10	11

Ordering table

Size	10	Condi- tions	Code	Enter code
M 1	Module No.	525 675		
2	Valve terminal	Valve terminal type 80, Smart Cubic, CPV-SC	80P	80P
3	Size [mm]	10	-10	-10
4	Power supply [V]	Power supply 24 DC	-1	
		Power supply 12 DC	-5	
5	Electrical connection	Connection for multi-pin cable Sub-D, 15-pin	1 MS	
		Connection for flat cable, 20-pin	2 MF	
		Connection for multi-pin cable Sub-D, 26-pin	2 MH	
6	Position of working ports	On valve sub-base	-P	-P
7	Pneumatic working ports, per valve position	Threaded connection M5	2 B	
		Push-in fittings QS-3	2 E	
		Push-in fittings QS-4	F	
8	Manual override	Manual override, push-in/detenting	-N	
		Manual override blocked	-V	
9	Pneumatic supply	Internal pilot air supply, silencer	-S	
		External pilot air supply, silencer	-T	
		Internal pilot air supply, ducted exhaust air	-V	
		External pilot air supply, ducted exhaust air	-X	
10	Pneumatic supply connection	Supply at left	L	L
11	Type of connections	Threaded connection M7	C	
		Push-in fittings QS-6	G	

1 MS Max. 12 valve positions possible.

2 MF, MH, B, E, N, K, J, D, L, T, S, U
Not possible with power supply 5.

Transfer order code

529 675	80P	10			P				L	
1	2	3	4	5	6	7	8	9	10	11

Valve terminal type 80 CPVSC1, Smart Cubic – Multi-pin

Ordering data – Modular products



M	Mandatory data	O	Options
	Equipment at valve position 0 ... 15 12 Valves: M, N, K, J, D, L, T, S, U Valve position 0 1 2 3 4 5 6 7 8 9 10 11 12 13 14 15 - _____ -	User documentation B, D, E, F, I, S, V - _____ -	Accessories CP, CQ, CR, H, T + _____ +
	12	13	14

Ordering table						
Size		10	Condi- tions	Code	Enter code	
M	12	Equipment at valve position 0 ... 15	[3]	-	-	
		Valves	5/2-way valve, single solenoid		M	Enter equip- ment selection for valve positions in order code
			3/2-way valve, normally open	[2]	N	
			3/2-way valve, normally closed	[2]	K	
			5/2-way valve, double solenoid	[2] [4]	J	
			2/2-way valve, normally closed	[2]	D	
			Vacant position	[2]	L	
			Pneumatic supply plate, duct 1 separate	[2] [5]	T	
			Pneumatic supply plate, duct 1/3/5 separate	[2] [5]	S	
			Pneumatic supply plate	[2]	U	
13	User documentation	Express waiver - no manual to be included (already available)		-B		
		Manuals, German		-D		
		Manuals, English		-E		
		Manuals, French		-F		
		Manuals, Italian		-I		
		Manuals, Spanish		-S		
		Manuals, Swedish		-V		
O	14	Accessories		+	+	
		Connecting cables	Connecting cable 2.5 m, Sub-D	[6]	CP	
			Connecting cable 5 m, Sub-D	[6]	CQ	
			Connecting cable 10 m, Sub-D	[6]	CR	
		H-rail mounting	1		H	
Inscription label holder	1		T			

[2] **MF, MH, B, E, N, K, J, D, L, T, S, U**
Not possible with power supply 5.

[3] **Equipment at valve position 0 ... 15**
Valve terminal must be equipped with exactly 4, 8, 12 or 16 valve positions. Exception:
Electrical connection MS: max. 12 valve positions.
Valve positions must always be configured from the left.

[4] **J** Double solenoid valve occupies 2 valve positions.
Cannot be mounted at the last valve position.

[5] **T, S** Can be mounted anywhere, however ensure adequate compressed air supply and exhausting
(for more than 2 successive valves).

[6] **CP, CQ, CR**
Not with electrical connection MF.

Transfer order code

0	1	2	3	4	5	6	7	8	9	10	11	12	13	14	15
- _____ -												- _____ -	+ _____ +		
12												13	14		

Valve terminal type 80 CPVSC1, Smart Cubic – Fieldbus Direct



Ordering data – Modular products

M Mandatory data →

Module No.	Valve terminal	Size	Electrical connection	Position of working ports	Pneumatic working ports	Manual override	Pneumatic supply	Pneumatic supply connection	Type of connections
538 510	81P	10	DN	P	B E F	N V	S T V X	L	C G
Ordering example									
538 510	81P	10	DN	P				L	
1	2	3	4	5	6	7	8	9	10

Ordering table

Size	Conditions	Code	Enter code
10			
M 1 Module No.	538 510		
2 Valve terminal	Valve terminal type 80, Smart Cubic, CPV-SC	81P	81P
3 Size [mm]	10	-10	-10
4 Electrical connection	DeviceNet	-DN	-DN
5 Position of working ports	On valve	-P	-P
6 Pneumatic working ports, per valve position	Threaded connection M5	B	
	Push-in fittings QS-3	E	
	Push-in fittings QS-4	F	
7 Manual override	Manual override, push-in/detenting	-N	
	Manual override blocked	-V	
8 Pneumatic supply	Internal pilot air supply, silencer	-S	
	External pilot air supply, silencer	-T	
	Internal pilot air supply, ducted exhaust air	-V	
	External pilot air supply, ducted exhaust air	-X	
9 Pneumatic supply connection	Supply at left	L	L
10 Type of connections	Threaded connection M7	C	
	Push-in fittings QS-6	G	

Transfer order code

538 510	81P	-	10	-	DN	-	P			-			L	
1	2		3		4		5	6	7		8	9	10	

Valve terminal type 80 CPVSC1, Smart Cubic – Fieldbus Direct

Ordering data – Modular products

M	Mandatory data	O	Options	
	<p>Equipment at valve position 0 ... 15</p> <p>11 Valves: M, N, K, J, D, L, T, S, U</p> <p>Valve position</p> <p>0 1 2 3 4 5 6 7 8 9 10 11 12 13 14 15</p> <p>- M N M K M K J J</p> <p>11</p>		<p>User documentation</p> <p>D, E, F, I, S, V</p> <p>- D</p> <p>12</p>	<p>Accessories</p> <p>...D, H, T</p> <p>+ HT</p> <p>13</p>

Ordering table						
Size			Condi- tions	Code	Enter code	
M	11 Equipment at valve position 0 ... 15		[1]	-	-	
		Valves	5/2-way valve, single solenoid		M	Enter equip- ment selection for valve positions in order code
			3/2-way valve, normally open		N	
			3/2-way valve, normally closed		K	
			5/2-way valve, double solenoid	[2]	J	
			2/2-way valve, normally closed		D	
			Vacant position		L	
			Pneumatic supply plate, duct 1 separate	[3]	T	
			Pneumatic supply plate, duct 1/3/5 separate	[3]	S	
			Pneumatic supply plate		U	
O	12 User documentation	Manuals, German		-D		
		Manuals, English		-E		
		Manuals, French		-F		
		Manuals, Italian		-I		
		Manuals, Spanish		-S		
		Manuals, Swedish		-V		
		13 Accessories				
Connector plug straight	1 ... 99			...D		
H-rail mounting	1			H		
Inscription label holder	1			T		

- [1] **Equipment at valve position 0 ... 15**
Number of valve positions: 4, 8, 12, 16.
Valve positions must always be configured from the left.
- [2] **J** Double solenoid valve occupies 2 valve positions.
Cannot be mounted at the last valve position.
- [3] **T, S** Can be mounted anywhere, however ensure adequate compressed air supply and exhausting (for more than 2 successive valves).

Transfer order code

0	1	2	3	4	5	6	7	8	9	10	11	12	13	14	15
-													+		
11											12	13			



Valve terminal type 80 CPVSC1, Smart Cubic



Accessories

Application-optimised valve terminals
Smart Cubic

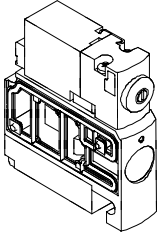
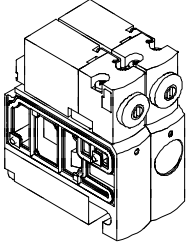
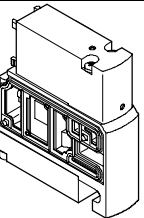
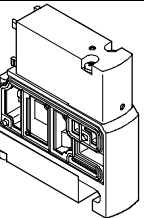
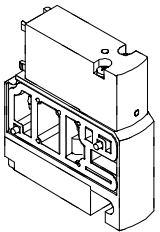
3.1

Ordering data – Valves			
Designation	Type	Part No.	
	Solenoid valve with connections M5		
	5/2-way valve, single solenoid	CPVSC1-M1H-M-P-M5C	527 550
	5/2-way valve, double solenoid	CPVSC1-M1H-J-P-M5C	527 553
	3/2-way valve, normally open	CPVSC1-M1H-N-P-M5C	527 551
	3/2-way valve, normally closed	CPVSC1-M1H-K-P-M5C	527 552
	2/2-way valve, normally closed	CPVSC1-M1H-D-P-M5C	527 554
	Solenoid valve with QS-3 push-in fittings		
	5/2-way valve, single solenoid	CPVSC1-M1H-M-P-Q3C	527 555
	5/2-way valve, double solenoid	CPVSC1-M1H-J-P-Q3C	527 558
	3/2-way valve, normally open	CPVSC1-M1H-N-P-Q3C	527 556
	3/2-way valve, normally closed	CPVSC1-M1H-K-P-Q3C	527 557
	2/2-way valve, normally closed	CPVSC1-M1H-D-P-Q3C	527 559
	Solenoid valve with QS-4 push-in fittings		
	5/2-way valve, single solenoid	CPVSC1-M1H-M-P-Q4C	527 560
	5/2-way valve, double solenoid	CPVSC1-M1H-J-P-Q4C	527 563
	3/2-way valve, normally open	CPVSC1-M1H-N-P-Q4C	527 561
	3/2-way valve, normally closed	CPVSC1-M1H-K-P-Q4C	527 562
	2/2-way valve, normally closed	CPVSC1-M1H-D-P-Q4C	527 564
	Plates with integrated connections		
Vacant position, with blanking plate	CPVSC1-RP-B	527 527	
	Supply plate M5		
	Duct 1 separate	CPVSC1-SP-P-M5	527 528
	Duct 1/3/5 separate	CPVSC1-SP-PRS-M5	527 530
	Without duct separation	CPVSC1-SP-M5	527 532
	Supply plate, QS-4 push-in fitting		
	Duct 1 separate	CPVSC1-SP-P-Q4	527 529
Duct 1/3/5 separate	CPVSC1-SP-PRS-Q4	527 531	
Without duct separation	CPVSC1-SP-Q4	527 533	
	Cover for manual override		
	10 pieces	CPVSC1-MO-V	527 393
	Cover for manual override	CPVSC1-HV	527 642

Valve terminal type 80 CPVSC1, Smart Cubic

Accessories



Ordering data – Accessories				
Designation			Type	Part No.
Power supply				
	MicroStyle M12, 5-pin socket (B-coded)	for 0.75 mm ²	NTSD-GD-9-M12-5POL-RK	538 999
Fieldbus connection				
	Fieldbus socket for MicroStyle connection, M12, socket (A-coded)		FBSD-GD-9-5POL	18 324
Connecting cable, IP20 for multi-pin plug connection				
	Sub-D, 15-pin, up to 12 valve positions for code MS Material: PVC Suitable for chain link trunking	2.5 m	KMP6-15P-12-2,5	527 543
		5 m	KMP6-15P-12-5	527 544
		10 m	KMP6-15P-12-10	527 545
	Sub-D, 26-pin, up to 16 valve positions for code MH Material: PVC Suitable for chain link trunking	2.5 m	KMP6-26P-16-2,5	527 546
		5 m	KMP6-26P-16-5	527 547
		10 m	KMP6-26P-16-10	527 548
Valve terminal connection				
	Angled plug – angled socket WS-WD	0.5 m	KVI-CP-1-WS-WD-0,5	178 564
		2 m	KVI-CP-1-WS-WD-2	163 139
		5 m	KVI-CP-1-WS-WD-5	163 138
	Plug straight GS-WD	5 m	KVI-CP-1-GS-WD-5	163 137
		8 m	KVI-CP-1-GS-WD-8	163 136
	Plug straight GS-GD	2 m, for chain link trunking	KVI-CP-2-GS-GD-2	170 234
		5 m, for chain link trunking	KVI-CP-2-GS-GD-5	170 235
		8 m, for chain link trunking	KVI-CP-2-GS-GD-8	165 616





Valve terminal type 80 CPVSC1, Smart Cubic

FESTO

Accessories

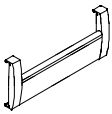
Application-optimised valve terminals
Smart Cubic

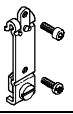
3.1

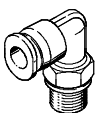
Ordering data – Accessories				
Designation		Type	Part No.	
Inscription labels for valve identification				
	80 pieces, 9x4.5 mm	MH-BZ-80x	197 259	
Inscription label holder				
	1 piece	for 4 valves	CPVSC1-ST-4	527 631
		for 8 valves	CPVSC1-ST-8	527 633
		for 12 valves	CPVSC1-ST-12	527 635
		for 16 valves	CPVSC1-ST-16	527 637
Mounting				
	Screw for additional terminal mounting	M3x45	527 643	
	Mounting	CPVSC-HS35	527 639	
Push-in fitting for working ports				
	Connecting thread M5 for tubing O.D.	3 mm	QSM-M5-3	153 302
		4 mm	QSM-M5-4	153 304
		3 mm	QSM-M5-3-I	153 313
		4 mm	QSM-M5-4-I	153 315
	Connecting thread M7 for tubing O.D.	6 mm	QSM-M5-6-I	153 317
		4 mm	QSM-M7-4-I	153 319
		6 mm	QSM-M7-6-I	153 321
		Push-in L-fitting for working ports		
	Connecting thread M5 for tubing O.D.	3 mm	QSML-M5-3	153 331
		4 mm	QSML-M5-4	153 333
		6 mm	QSML-M5-6	153 335
		4 mm	QSMLL-M5-4	153 339
		6 mm	QSMLL-M5-6	153 341
		Connecting thread M7 for tubing O.D.	4 mm	QSML-M7-4
	6 mm		QSML-M7-6	186 353
	4 mm		QSMLL-M7-4	186 354
	6 mm		QSMLL-M7-6	186 355

Valve terminal type 80 CPVSC1, Smart Cubic



Accessories

Ordering data – Accessories				
Designation		Type	Part No.	
Silencers				
	Connecting thread M5	U-M5	4 645	
	Connecting thread M5	UC-M5	165 003	
	Connecting thread M7	UC-M7	161 418	
	Connection type, push-in sleeve	UC-QS-3H	165 005	
	Connection type, push-in sleeve	UC-QS-4H	165 006	
	Connection type, push-in sleeve	UC-QS-6H	165 007	
Blanking plugs				
	Thread M5	B-M5-B	174 308	
	Thread M7	B-M7	174 309	
Plugs				
	Blanking plug for tubing O.D. 4 mm	QSC-4H	153 267	
	Blanking plug for tubing O.D. 6 mm	QSC-6H	153 268	
	Blanking plug for tubing O.D. 3 mm	QSMC-3H	153 382	
Software				
	CD-ROM	Valve terminals	PCD-VALVE-T	183 350
		Utilities	PCD-VI-UTILITIES-2	533 500
User documentation				
	User documentation – Pneumatics, Valve terminal CPVSC	German	P.BE-CPVSC-DE	530 925
		English	P.BE-CPVSC-EN	530 926
		French	P.BE-CPVSC-FR	530 927
		Spanish	P.BE-CPVSC-ES	530 928
		Italian	P.BE-CPVSC-IT	530 929
		Swedish	P.BE-CPVSC-SV	530 930
	User documentation – Fieldbus DeviceNet	German	P.BE-CPASC-CPVSC-DN-DE	539 008
		English	P.BE-CPASC-CPVSC-DN-EN	539 009
		French	P.BE-CPASC-CPVSC-DN-FR	539 010
		Spanish	P.BE-CPASC-CPVSC-DN-ES	539 011
		Italian	P.BE-CPASC-CPVSC-DN-IT	539 012
		Swedish	P.BE-CPASC-CPVSC-DN-SV	539 013