

# Fine and micro filters, LFMB-H/LFMA-H, H series

Peripherals overview and type codes

## Peripherals overview

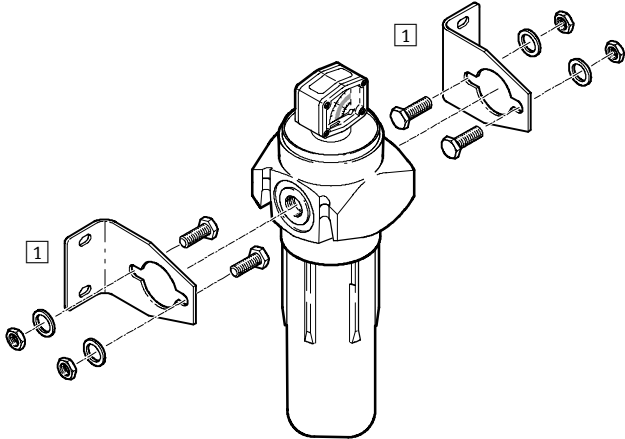

Mounting attachments and accessories	Brief description	→ Page
1 Mounting bracket (2 pcs.) LFMM	The fine and micro filters are mounted on the wall using mounting brackets LFMM	3 / 4.3-9

## Type codes



Service function	
LFMA	Micro filter
LFMB	Fine filter

Pneumatic connection	
1/2	Thread G1/2
3/4	Thread G3/4
1	Thread G1

Series	
H	Series

Condensate drain	
A	Fully automatic

# Fine and micro filters, LFMB-H/LFMA-H, H series

Technical data

Function

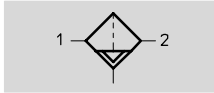

- Flow rate  
1,100 ... 5,200 l/min
- Temperature range  
-10 ... +60 °C
- Input pressure  
0 ... 16 bar



Various industries require fine or micro-filtered air: chemicals, pharmaceuticals, process technology, food industry, etc. Festo fine and micro filters clean compressed air almost completely of any remaining minute water and oil droplets, together with any dirt particles.

- Robust die-cast design
- Very high flow rates
- All filter units with automatic condensate drain and differential pressure gauge for displaying filter pollution

- Fine and micro-filters fulfil stringent air quality requirements in accordance with ISO 8573-1
- Easy replacement of filter components
- Resistant to mineral and synthetic lubricants

Fine filter function

Compressed air flows through a filter cartridge made of borosilicate fibre-glass, from the inside to the outside. As the compressed air flows through the fibre tissues, large particles are prevented from passing the filtration bed by simple inertia, or are collected by collision with the fibres.

Separation of fine and very fine oil vapour particles and solid impurities down to 0.01 micron results from an extremely fine filter tissue. The smallest particles collect on the fibres where they form larger droplets (coalescing effect), which run off due to gravity.

The flow rate recommended for each filter must be observed in order to prevent the oil-water emulsion which has accumulated in the foam jacket from being drawn in by the compressed air. Compressed air should be pre-filtered to 5 µm where fine filters and micro-filters are used.

General technical data						
Type	Micro filters LFMA			Fine filters LFMB		
Pneumatic connection	G1/2	G3/4	G1	G1/2	G3/4	G1
Design	Fibre filter					
Type of mounting	In-line installation					
	Via accessories					
Mounting position	Vertical ±5°					
Operating medium	Compressed air, filtered, grade of filtration 1 µm			Compressed air, filtered, grade of filtration 5 µm		
Grade of filtration [µm]	0.01			1		
Residual oil content [mg/m <sup>3</sup> ]	≤0.01			≤0.5		
Filter efficiency [%]	99.9999					
Input pressure [bar]	0 ... 16					
Air purity classes per ISO 8573-1						
Particulate	1			2		
Atomised oil	2			3		

# Fine and micro filters, LFMB-H/LFMA-H, H series

Technical data



Standard nominal flow rate <sup>1)</sup> qnN [l/min]			
Connection	G <sup>1</sup> / <sub>2</sub>	G <sup>3</sup> / <sub>4</sub>	G1
Micro filters LFMA	1,100	2,000	3,400
Fine filters LFMB	1,600	3,300	5,200

1) With 6 bar input pressure and Δp = 0.07 bar.

Ambient conditions		
Ambient temperature [°C]	-10 ... +60	
Corrosion resistance CRC <sup>1)</sup>	2	

1) Corrosion resistance class 2 according to Festo standard 940 070

Components requiring moderate corrosion resistance. Externally visible parts with primarily decorative surface requirements which are in direct contact with a surrounding industrial atmosphere or media such as cooling or lubricating agents.

Weights [g]			
	G <sup>1</sup> / <sub>2</sub>	G <sup>3</sup> / <sub>4</sub>	G1
Micro filters LFMA	1,100	2,800	3,200
Fine filters LFMB	1,100	2,800	3,200

## Materials

Sectional view

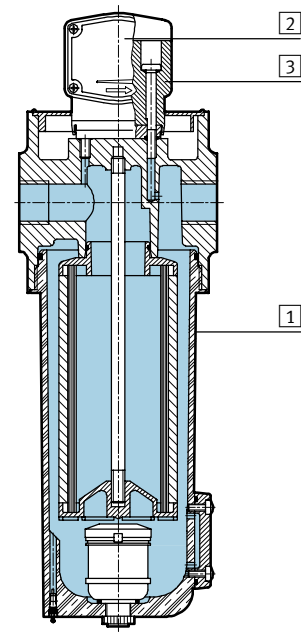

Fine and micro filters		
1	Housing/bowl	Die-cast zinc
2	Pressure gauge sight glass	Polymethylmethacrylate
3	Pressure gauge housing	Polyamide
-	Seals	Nitrile rubber

# Fine and micro filters, LFMB-H/LFMA-H, H series

Technical data

## Standard flow rate $q_n$ as a function of the output pressure $\Delta p_{1-2}$

LFMA-1/2-H-A

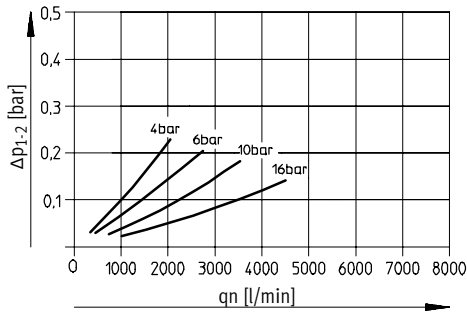

LFMB-1/2-H-A

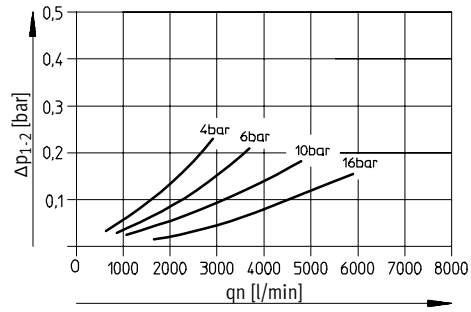

LFMA-3/4-H-A

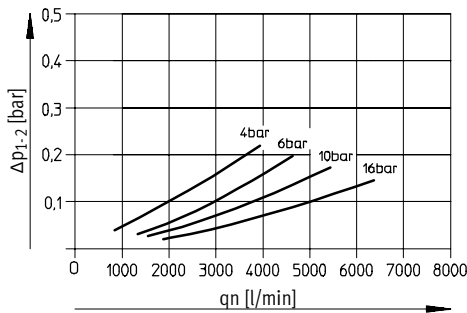

LFMB-3/4-H-A

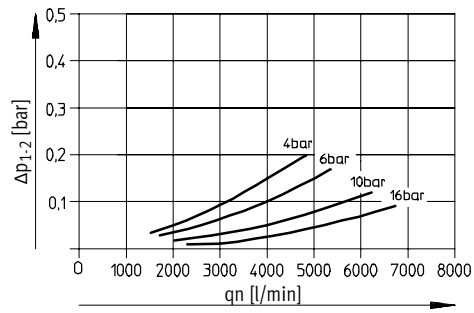

LFMA-1-H-A

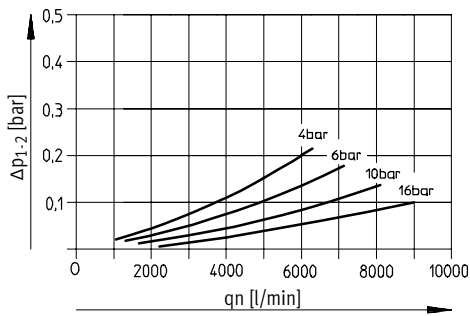

LFMB-1-H-A

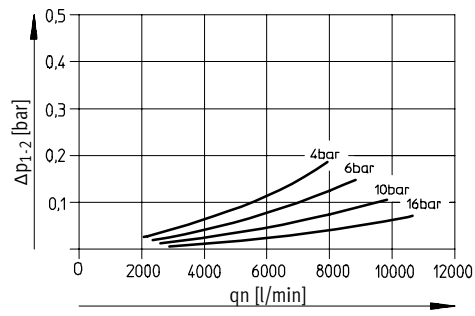

# Fine and micro filters, LFMB-H/LFMA-H, H series

Technical data



## Dimensions

Download CAD data → [www.festo.com/en/engineering](http://www.festo.com/en/engineering)

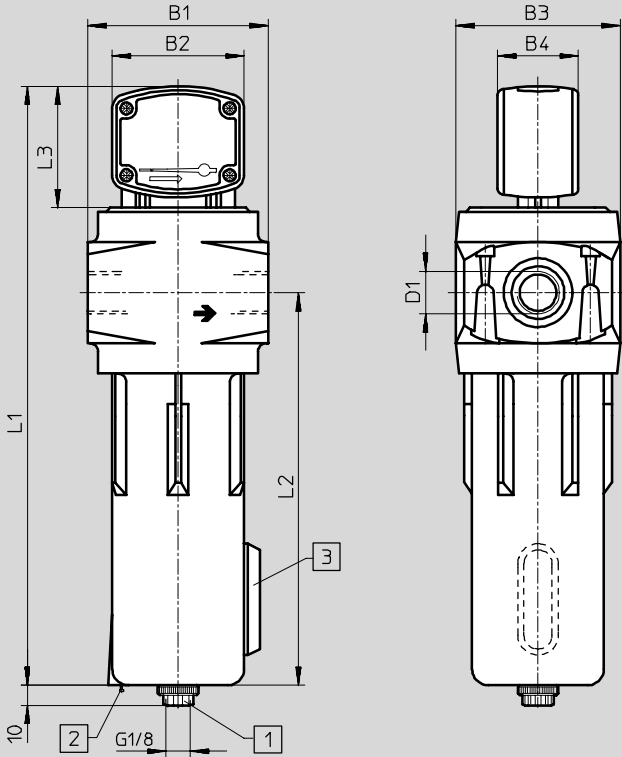

- 1 Fully automatic condensate drain (tightening torque 1 Nm)
- 2 Pressure relief valve
- 3 Sight glass for condensate level

→ Flow direction

Type	B1	B2	B3	B4	D1	L1	L2	L3
LFMA-1/2-H-A	89	65	81	39	G1/2	294	194	60
LFMB-1/2-H-A			112		G3/4			
LFMA-3/4-H-A	120		112		G1			
LFMB-3/4-H-A	120		112		G1			

Ordering data				
Connection	Grade of filtration 1 µm		Grade of filtration 0.01 µm	
	Part No.	Type	Part No.	Type
G1/2	162 818	LFMB-1/2-H-A	162 815	LFMA-1/2-H-A
G3/4	162 819	LFMB-3/4-H-A	162 816	LFMA-3/4-H-A
G1	162 820	LFMB-1-H-A	162 817	LFMA-1-H-A

Individual units  
Filter

4.3

# Filter combinations LFMBA-H, H series

Peripherals overview

## Peripherals overview

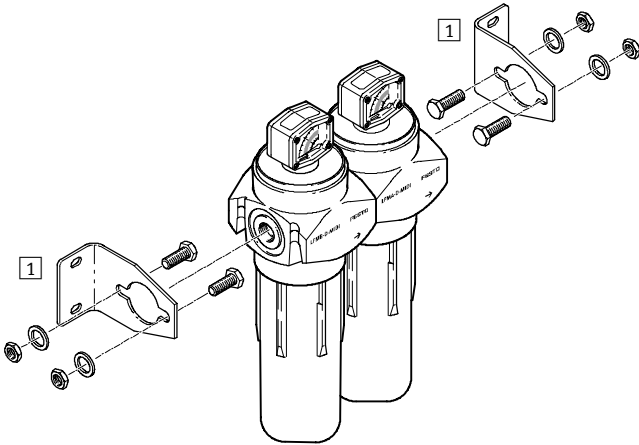

Mounting attachments and accessories	Brief description	→ Page
1 Mounting bracket (2 pcs.) LFMM	The filter combination is attached to the wall by means of the mounting brackets LFMM	3 / 4.3-9

## Type codes

	LFMBA	-	1/2	-	H	-	A
<b>Service function</b>							
LFMBA	Filter combination						
<b>Pneumatic connection</b>							
1/2	Thread G1/2						
3/4	Thread G3/4						
1	Thread G1						
<b>Series</b>							
H	Series						
<b>Condensate drain</b>							
A	Fully automatic						

# Filter combinations LF MBA-H, H series

Technical data



Function

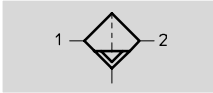

- - Flow rate  
800 ... 2,600 l/min
- - Temperature range  
-10 ... +60 °C
- - Input pressure  
0 ... 16 bar



Various industries require fine or micro-filtered air: chemicals, pharmaceuticals, process technology, food industry, etc. Festo fine and micro filters clean compressed air almost completely of any remaining minute water and oil droplets, together with any dirt particles.

- Available as pre-assembled filter combination
- Very high flow rates
- All filter units with automatic condensate drain and differential pressure gauge for displaying filter pollution

- Fine and micro-filters fulfil stringent air quality requirements in accordance with ISO 8573-1
- Easy to replace filter components
- Resistant to mineral and synthetic lubricants

General technical data			
Type	Filter combination LF MBA		
Pneumatic connection	G $\frac{1}{2}$	G $\frac{3}{4}$	G1
Design	Fibre filter		
Type of mounting	In-line installation		
	Via accessories		
Mounting position	Vertical $\pm 5^\circ$		
Grade of filtration	[ $\mu\text{m}$ ]	0.01	
Residual oil content	[ $\text{mg}/\text{m}^3$ ]	$\leq 0.01$	
Filter efficiency	[%]	99.9999	
Input pressure	[bar]	0 ... 16	
Air purity classes per ISO 8573-1			
Particulate		1	
Atomised oil		2	

Standard nominal flow rate <sup>1)</sup> q <sub>N</sub> [l/min]			
Connection	G $\frac{1}{2}$	G $\frac{3}{4}$	G1
LF MBA-...-H-A	800	1,400	2,600

1) With 6 bar input pressure and  $\Delta p = 0.07$  bar.

Ambient conditions			
Variant	G $\frac{1}{2}$	G $\frac{3}{4}$	G1
Ambient temperature	[°C]	-10 ... +60	
Corrosion resistance	CRC <sup>1)</sup>	2	

1) Corrosion resistance class 2 according to Festo standard 940 070  
Components requiring moderate corrosion resistance. Externally visible parts with primarily decorative surface requirements which are in direct contact with a surrounding industrial atmosphere or media such as cooling or lubricating agents.

# Filter combinations LFMBA-H, H series

Technical data

Weights [g]			
	G $\frac{1}{2}$	G $\frac{3}{4}$	G1
LFMBA-...	2,300	5,700	6,500

## Materials

Sectional view

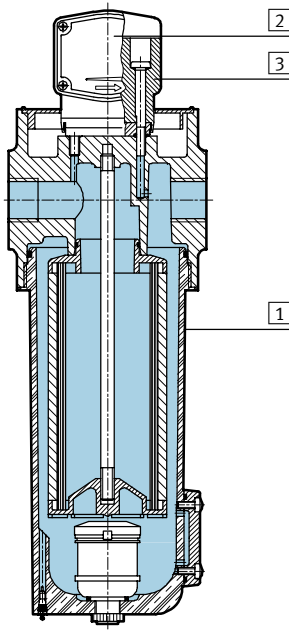

Fine and micro filters		
1	Housing/bowl	Die-cast zinc
2	Pressure gauge sight glass	Polymethylmethacrylate
3	Pressure gauge housing	Polyamide
-	Seals	Nitrile rubber

### Standard flow rate $q_n$ as a function of the output pressure $\Delta p_{1-2}$

LFMBA- $\frac{1}{2}$ -H-A

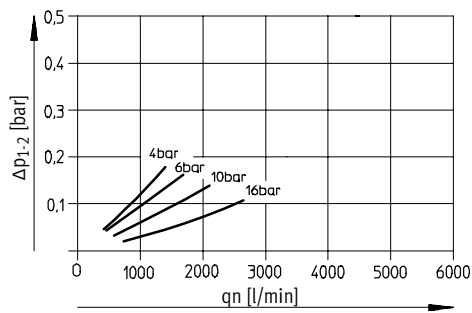

LFMBA- $\frac{3}{4}$ -H-A

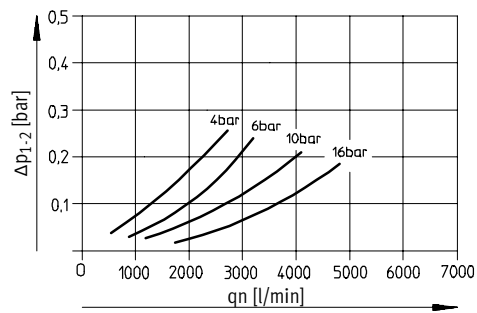

LFMBA-1-H-A

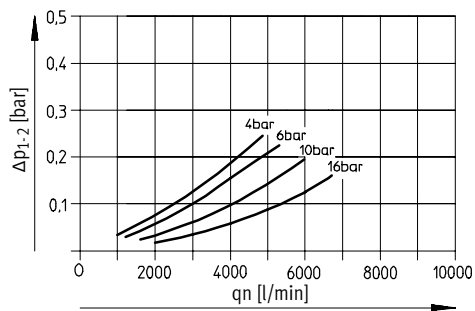



# Filter combinations LF MBA-H, H series

Technical data



## Dimensions

Download CAD data → [www.festo.com/en/engineering](http://www.festo.com/en/engineering)

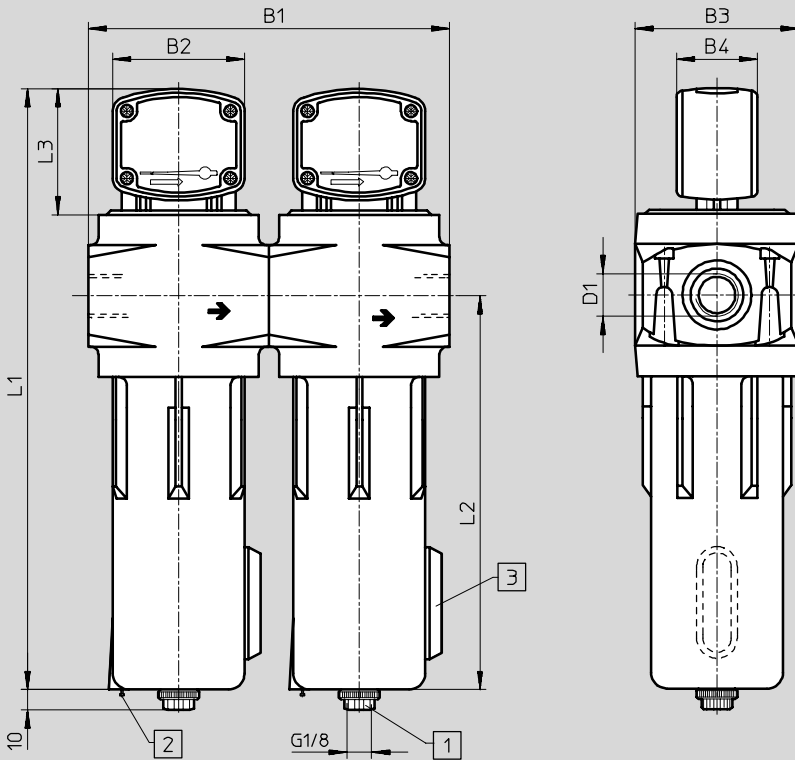

- 1 Fully automatic condensate drain (tightening torque 1 Nm)
- 2 Pressure relief valve
- 3 Sight glass for condensate level

→ Flow direction

Type	B1	B2	B3	B4	D1	L1	L2	L3
LFMBA-1/2-H-A	178	65	81	39	G1/2	294	194	60
LFMBA-3/4-H-A	240		112		G3/4	366	251	
LFMBA-1-H-A	240		112		G1	466	351	

Ordering data		
Connection	Part No.	Type
G1/2	162 821	LFMBA-1/2-H-A
G3/4	162 822	LFMBA-3/4-H-A
G1	162 823	LFMBA-1-H-A

Individual units  
Filter

4.3

# Fine and micro filters, H series

Accessories



## Mounting bracket LFMM

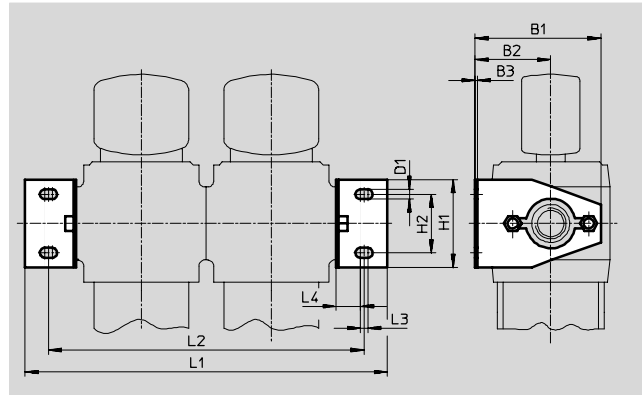
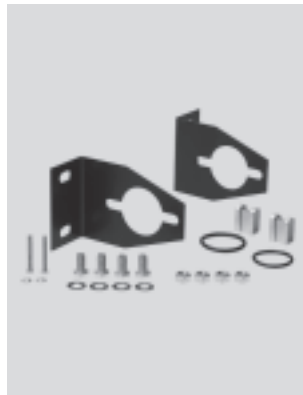

Ordering data														Part No.	Type
Connection	B1	B2	B3	D1	H1	H2	LFMB/A		LFMBA		L3	L4			
							L1	L2	L1	L2					
G $\frac{1}{2}$	86	52	1.6	7	60	40	159	127	248	216	5	16.5	<b>162 830</b>	<b>LFMM-<math>\frac{1}{2}</math>-H</b>	
G $\frac{3}{4}$ , G1	116	68	2	9	80	60	200	157	320	277	5	16	<b>162 831</b>	<b>LFMM-<math>\frac{3}{4}</math>-1-H</b>	

## Connection piece LFMV for connecting two filters

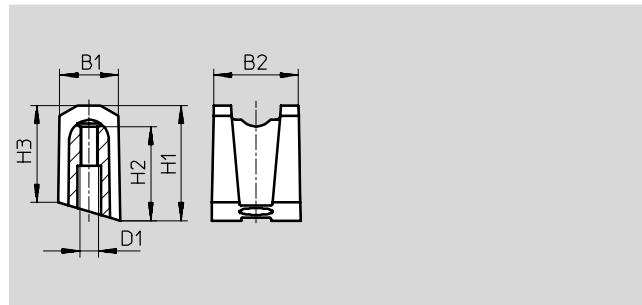

Ordering data								Part No.	Type
Connection	B1	B2	D1	H1	H2	H3			
G $\frac{1}{2}$	9.75	14	M3x0.5	19	15.5	16	<b>162 832</b>	<b>LFMV-<math>\frac{1}{2}</math>-H</b>	
G $\frac{3}{4}$ , G1	12.5	20	M4	29	26	25.5	<b>162 833</b>	<b>LFMV-<math>\frac{3}{4}</math>-1-H</b>	

# Fine and micro filters, H series

Accessories



Filter cartridge LFMBP/LFMAP

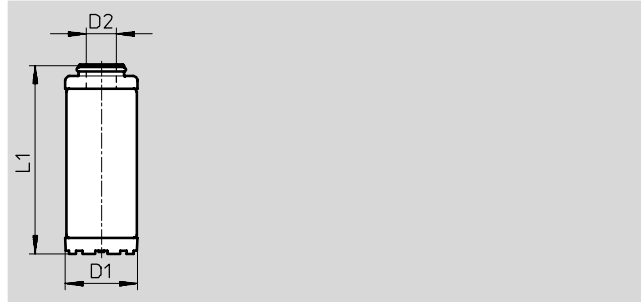

Ordering data					
Connection	D1 Ø	D2 Ø	L1	Part No.	Type
For fine filter					
G <sup>1</sup> / <sub>4</sub>	35	6.75	74	185 689	LFMBP- <sup>1</sup> / <sub>4</sub> -H
G <sup>1</sup> / <sub>2</sub>	48	21.7	126	162 827	LFMBP- <sup>1</sup> / <sub>2</sub> -H
G <sup>3</sup> / <sub>4</sub>	72	33	168.8	162 828	LFMBP- <sup>3</sup> / <sub>4</sub> -H
G1	72	33	268.8	162 829	LFMBP-1-H
For micro filter					
G <sup>1</sup> / <sub>4</sub>	35	6.75	74	185 688	LFMAP- <sup>1</sup> / <sub>4</sub> -H
G <sup>1</sup> / <sub>2</sub>	48	21.7	126	162 824	LFMAP- <sup>1</sup> / <sub>2</sub> -H
G <sup>3</sup> / <sub>4</sub>	72	33	168.8	162 825	LFMAP- <sup>3</sup> / <sub>4</sub> -H
G1	72	33	268.8	162 826	LFMAP-1-H

Individual units  
Filter

4.3



# Filter silencers LFU

Technical data

FESTO

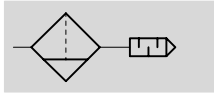
## Function



-  Flow rate  
6,000 ... 12,500 l/min
-  Temperature range  
0 ... +100 °C
-  Input pressure  
0 ... 16 bar

All exhaust air from pneumatic control systems is cleaned by the filter silencer.

Exhaust air is discharged into the atmosphere via a fine filter cartridge (degree of filtration: >99.99%).

At the same time, exhaust noise is greatly reduced. Condensate is collected in the lower plastic bowl and can be discharged via the condensate drain.



- Size G $\frac{1}{2}$ , G1
- Exhaust air is up to 99.99% free of oil and other contaminants.
- The silencer reduces exhaust noise regardless of frequency.

General technical data		
Type	LFU- $\frac{1}{2}$	LFU-1
Pneumatic connection	G $\frac{1}{2}$	G1
Type of mounting	Thread	
Mounting position	Vertical $\pm 5^\circ$	
Standard nominal flow rate <sup>1)</sup> [l/min]	6,000	12,500
Input pressure [bar]	0 ... 16	
Noise reduction	$\leq 40$ db(A)	

1) At 6 bar with respect to atmosphere.

Ambient conditions		
Ambient temperature [°C]	0 ... +100	
Corrosion resistance CRC <sup>1)</sup>	2	

1) Corrosion resistance class 2 according to Festo standard 940 070  
Components requiring moderate corrosion resistance. Externally visible parts with primarily decorative surface requirements which are in direct contact with a surrounding industrial atmosphere or media such as cooling or lubricating agents.

Weights [g]		
Connection	G $\frac{1}{2}$	G1
Filter silencer	570	1,010

# Filter silencers LFU

Technical data



## Materials

Sectional view

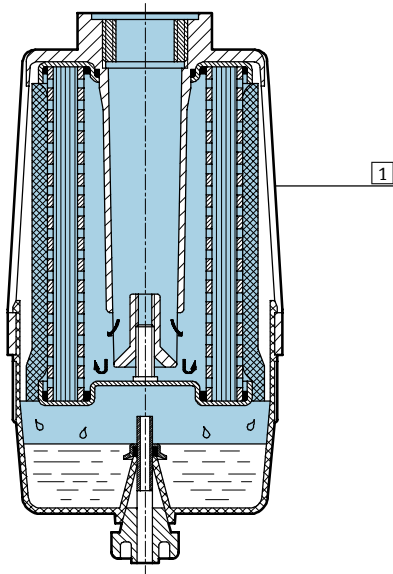

Filter silencer		
1	Housing	Aluminium, plastic
	Note on material	Free of copper, PTFE and silicone

Individual units  
Filter

4.3

## Dimensions

Download CAD data → [www.festo.com/en/engineering](http://www.festo.com/en/engineering)

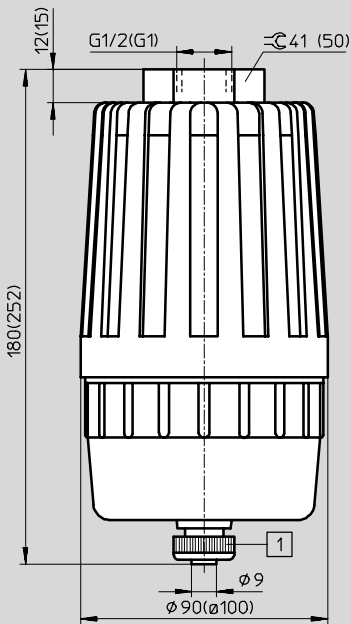

1 Condensate drain

LFU-1 = Dimensions in brackets

## Ordering data

Connection	Part No.	Type
G $\frac{1}{2}$	10 494	LFU- $\frac{1}{2}$
G1	10 495	LFU-1

## Filter silencers LFU

Accessories

FESTO

### Filter cartridge LFPU

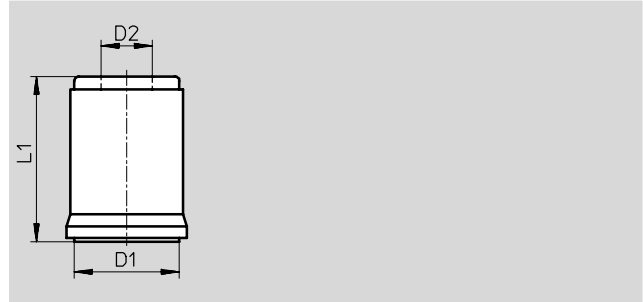

Ordering data					
Connection	D1	D2	L1	Part No.	Type
	∅	∅			
G <sup>1</sup> / <sub>2</sub>	70	34.8	110	<b>10 496</b>	<b>LFPU-1/2</b>
G1	82	42.8	180	<b>10 497</b>	<b>LFPU-1</b>