



- Shortest cycle times
- Compact design
- Simple planning, installation and commissioning
- Installation and adaptation concept



Handling module HSP

Key features at a glance

High functionality

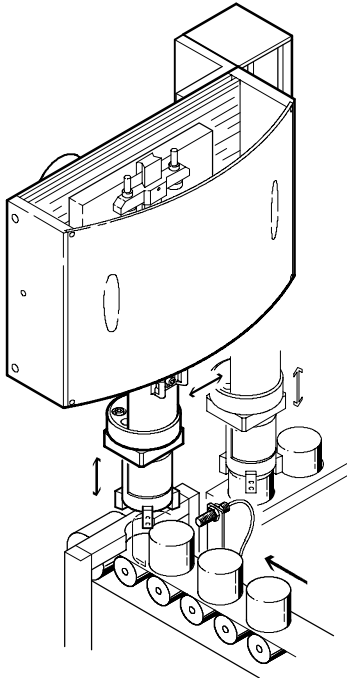

- Compact, space-saving design
- Simple commissioning
- Independent stroke adjustment
- Stroke range
 - Y-axis 52 ... 170 mm
 - Z-axis 20 ... 70 mm
- Working load up to 1.6 kg
- Cycle times of 0.6 ... 1.0 s attainable

The technology in detail

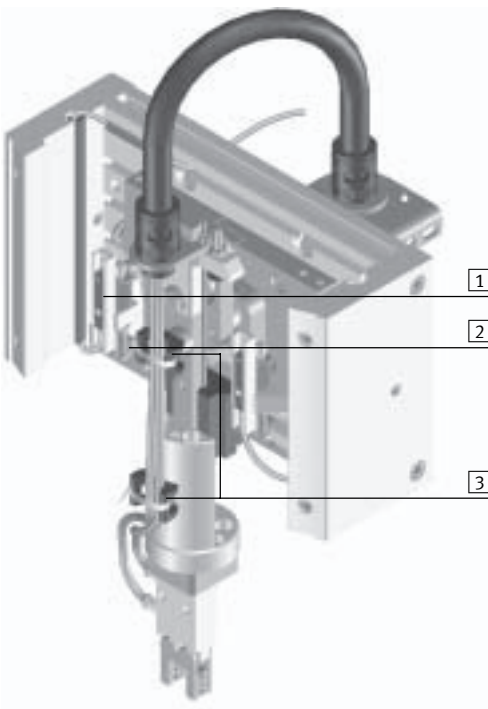

- 1 Proximity sensor cables are installed via profile slots in the side cover and in the back plate.



- 2 The pressure piece guarantees freedom from backlash and precision in the end positions and in the effective linear stroke along the Z-axis.



- 3 Cable binder holders facilitate the secure routing of tubing and cables.

Handling module HSP

Key features at a glance

HSP design with swivel module DSM

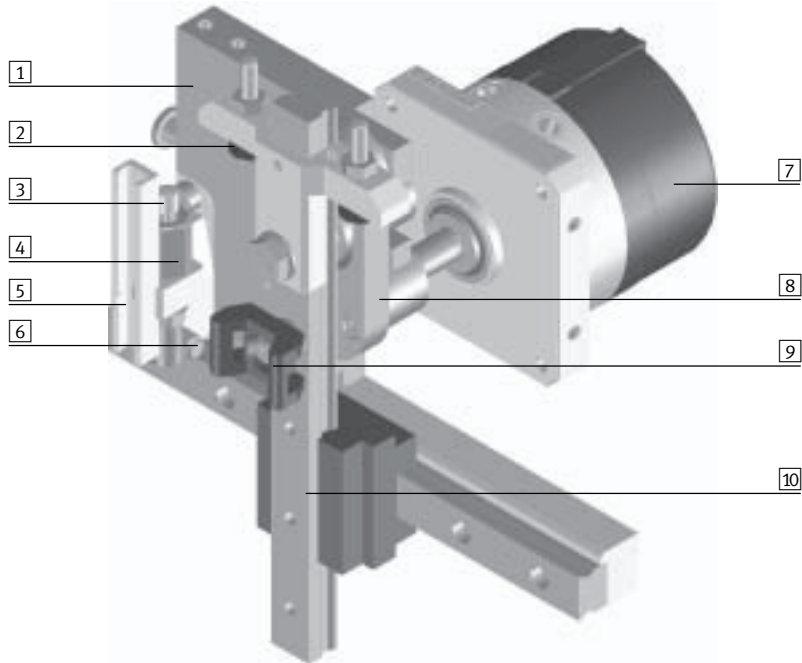

- 1 Slotted guide plate
- 2 Adjustable stop
- 3 Shock absorber YSRW
- 4 Stop sleeve
- 5 Sensor rail
- 6 Pressure piece
- 7 Swivel module DSM
- 8 Swivel lever
- 9 Cable binder holder
- 10 Cross-guide

HSP design without drive (rear side)

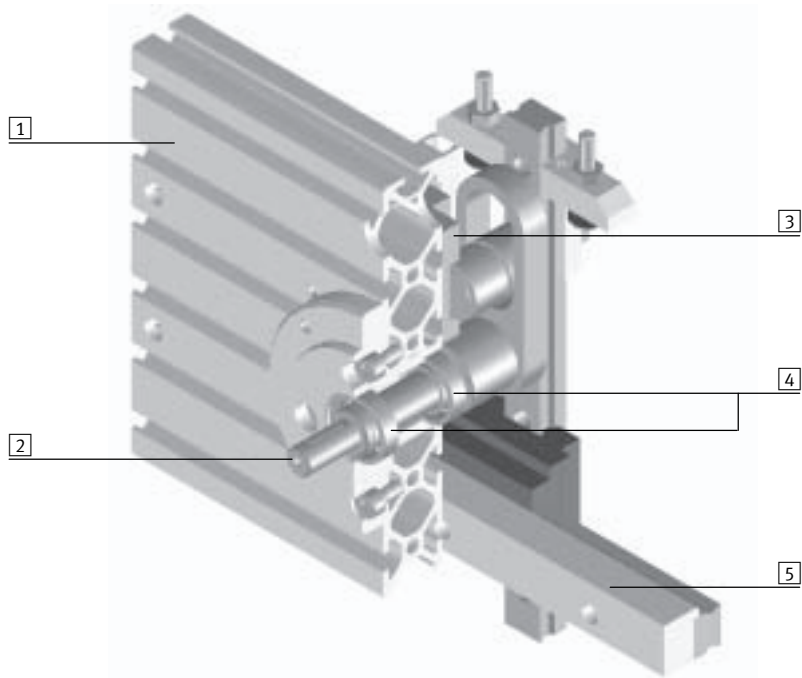

- 1 Back plate
- 2 Shaft with woodruff key
- 3 Slotted guide plate
- 4 Ball bearings
- 5 Aluminium rail for alignment of the guide plate

Handling module HSP

Peripherals overview

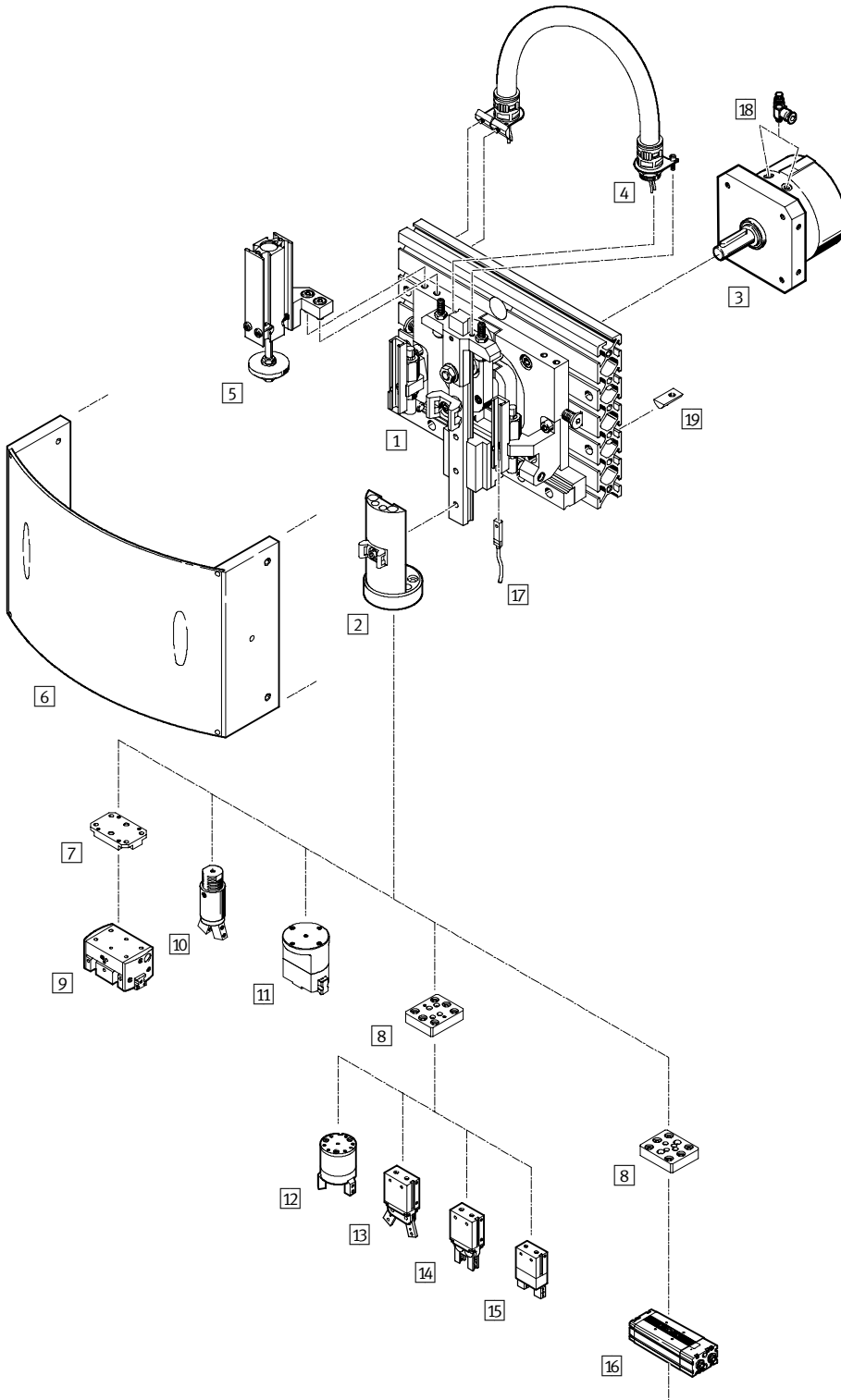

Handling module HSP

Peripherals overview and type codes

Accessories						
	Brief description	12	16	25	→ Page	
1	Handling module HSP	Standard module without accessories	■	■	■	1 / 7.2-6
2	Adapter kit HAPG	Interface for grippers, semi-rotary drives, etc.	■	■	■	1 / 7.2-18
3	Swivel module DSM	Pneumatic drive, adapted to every size	■	■	■	www.festo.com
4	Installation kit MKRP	Conduit for the protection of electrical cables and tubing	■	■	■	1 / 7.2-18
5	Wait position module BWL-/BWR-HSP	Function for pulling back the swivel arm from the operating area	■	■	■	1 / 7.2-19
6	Cover kit BSD-HSP	Protective function	■	■	■	1 / 7.2-19
7	Adapter kit HAPG	Interface between HSP and precision gripper	-	■	■	1 / 7.2-20
8	Adapter kit HAPG	Interface between HSP and standard gripper or semi-rotary drive	■	■	■	1 / 7.2-20
9	Precision gripper HGPP	The appropriate gripper for every application	-	■	■	1 / 7.2-20
10	Micro gripper HGWM		■	■	■	1 / 7.2-20
11	Micro gripper HGPM		■	■	■	1 / 7.2-20
12	Standard gripper HGD		-	■	■	1 / 7.2-20
13	Standard gripper HGW		■	■	■	1 / 7.2-20
14	Standard gripper HGR		■	■	■	1 / 7.2-20
15	Standard gripper HGP		■	■	■	1 / 7.2-20
16	Semi-rotary drive DRQD		■	■	■	1 / 7.2-20
17	Proximity sensor SME-/SMT-8	Sensing option for end positions	■	■	■	1 / 7.2-22
18	Non-return and flow control valve GRLA	Adjustment of speed of movement	■	■	■	1 / 7.2-23
19	Slot nut HMBN	Mounting option	■	■	■	1 / 7.2-23

Type codes



HSP		12	AP	SD	WR
Type	HSP	Handling module, double-acting			
Size [mm]					
Drive	AP	With swivel module DSM			
	AS	Without drive			
Function	SD	With protective cover			
Function	WR	Wait position on right			
	WL	Wait position on left			

Handling module HSP

Technical data

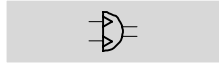
Function



-  Diameter
12, 16 and 25
-  Y-stroke length
52 ... 170
-  Z-stroke length
20 ... 70

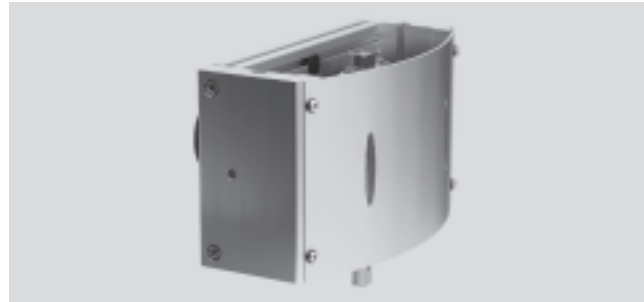

Construction		
Size	HSP with swivel module DSM	HSP without drive
Pneumatic connection	M5	-
Mode of operation	Double-acting	-
Operating medium	Filtered compressed air, lubricated or unlubricated	-
Constructional design	Swivel module	Drive shaft
	Cross-guide	
	Guided motion sequence	
Cushioning	Shock absorber at both ends, soft characteristic curve	
Position sensing	Via proximity sensor	
Type of mounting	Via through-holes	
	Via slot nuts	
Mounting position	Vertical guide rail	

Operating and environmental conditions			
Size	12	16	25
Operating pressure [bar] for HSP with DSM	4 ... 8		
Ambient temperature [°C]	0 ... +60		

Strokes [mm]			
Size	12	16	25
Y Y-stroke	52 ... 68	90 ... 110	130 ... 170
Z Z-stroke	20 ... 30	35 ... 50	50 ... 70
Za Z working stroke	5 ... 15	5 ... 20	5 ... 25

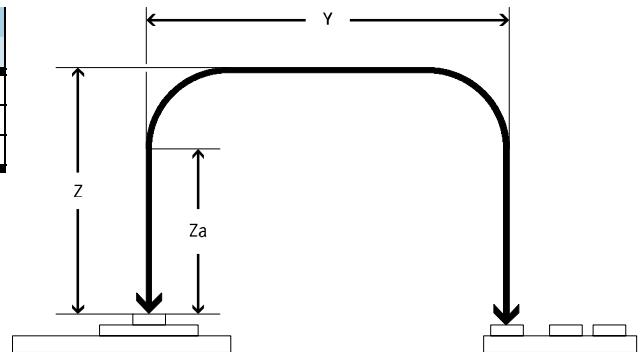

Forces [N]			
Size	12	16	25
Effective and pressing-in force at 6 bar for HSP with DSM	40	50	65
Permissible process force along Y-axis	30	35	50

Handling module HSP

Technical data



Repetition accuracy [mm]			
Size	12	16	25
Repetition accuracy	±0.01	±0.01	±0.02

To ensure low-vibration operation, the working load should be mounted as close as possible to the guide rail of the handling module.

Repetition accuracy is guaranteed by mounting the working load (adapter plate, rotary drive and/or gripper, gripper finger, workpiece) within the mounting surface of the adapter kit HAPG.

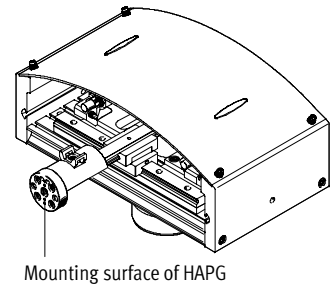

Mounting surface of HAPG

Weights [g]			
Size	12	16	25
HSP-...-AP	1900	2900	6400
HSP-...-AP-SD	2600	3400	7600
HSP-...-AP-SD-WR	2800	3600	8100
HSP-...-AP-SD-WL	2800	3600	8100
HSP-...-AS	1800	2700	6200
HSP-...-AS-SD	2500	3200	7400

Travel times t as a function of working load m for variant HSP-...-AP

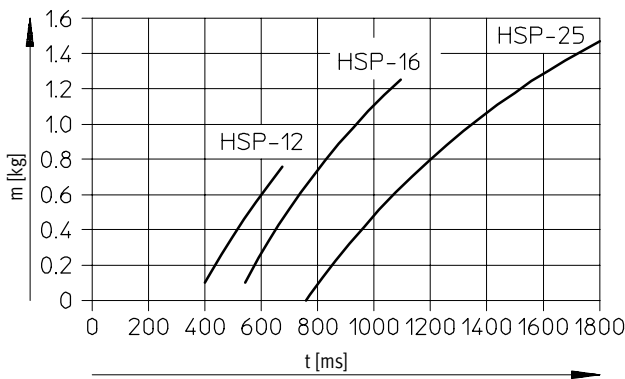

The travel time t is the time taken for the HSP to move from one end position to the other and back again.

The working load m is the load attached to the vertical guide rail (e.g. adapter, gripper, semi-rotary drive and workpiece)

Cycle times

The cycle time t_t comprises the travel time t and the dwell time t_e in the end positions.

$t_t = \text{travel time } t + \text{dwell time } t_e$
The value must not fall below the minimum cycle time.

Size	12	16	25
Min. cycle time [s]	0.6	0.8	1.0

Problem example for HSP-12-AP

Step 1:
The following values are assumed:
Working load = 0.15 kg
Dwell time $t_e = 2 \times 50$ ms
(50 ms per end position)

Step 2:
The travel time can be determined from the graph:
 $t = 400$ ms

Step 3:
This gives us a cycle time:
 $t_t = 400$ ms + 100 ms = 500 ms

Step 4:
The table gives us a min. cycle time of 600 ms. This means that the movement has to be controlled.

Handling module HSP

Technical data

Permissible static/dynamic characteristic load values

Cross-guide

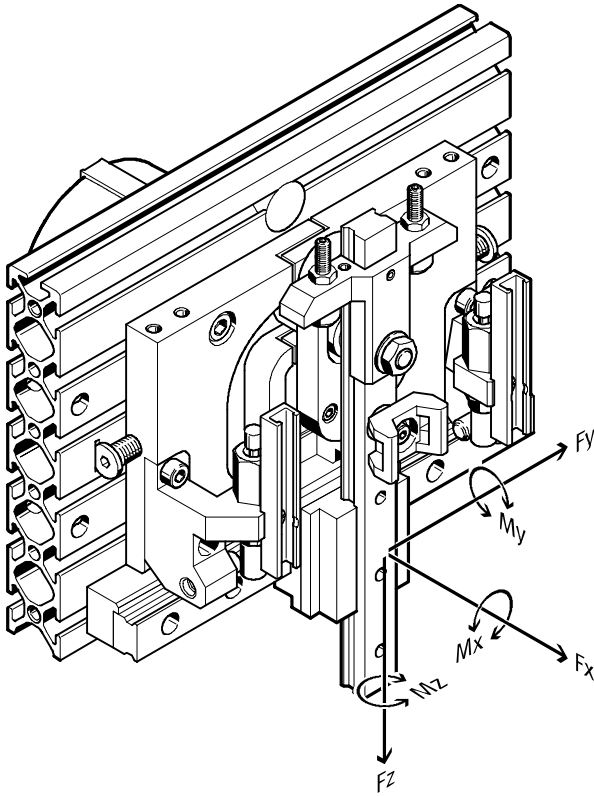

Handling units
Handling modules

7.2

Combined load

The torques apply to the centre of the vertical guide.

The following torque equation must be satisfied with combined load:

$$\frac{M_x}{M_{xperm.}} + \frac{M_y}{M_{yperm.}} + \frac{M_z}{M_{zperm.}} \leq 1$$

Dynamic characteristic load values			
Size	12	16	25
Max. torques [Nm] $M_{xperm.}, M_{yperm.}, M_{zperm.}$	1.1	2.4	3.2

Combined load

The torques apply to the centre of the vertical guide.

The following torque equation must be satisfied with combined load:

$$\frac{M_{ox}}{M_{oxperm.}} + \frac{M_{oy}}{M_{oyperm.}} + \frac{M_{oz}}{M_{ozperm.}}$$

Static characteristic load values			
Size	12	16	25
Max. torques [Nm] $M_{oxperm.}, M_{oyperm.}, M_{ozperm.}$	5	10	15

Handling module HSP

Technical data

Permissible static/dynamic characteristic load values
Without drive

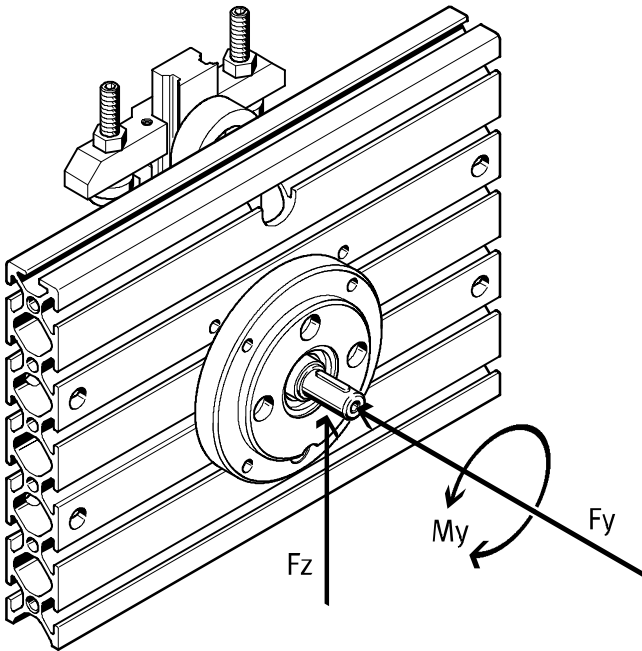

Characteristic load values				
Size		12	16	25
Max. axial force	[N]	18	30	50
$F_{yperm.}$				
Max. radial force	[N]	45	75	120
$F_{zperm.}$				
Max. driving torque	[Nm]	1.25	2.5	5
$M_{yperm.}$				

Mass moment of inertia J_0 as a function of the working load m (for cylinder sizing)

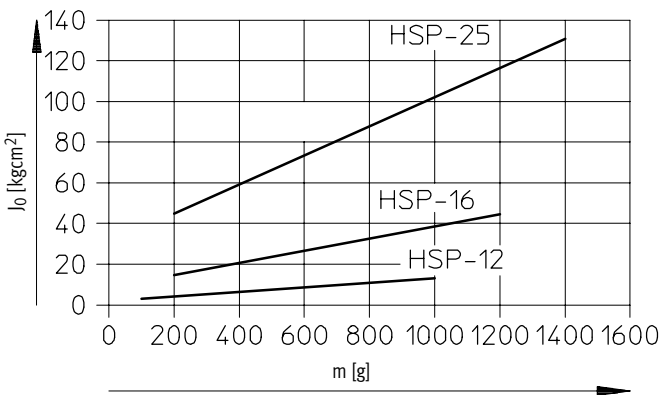

Handling module HSP

Technical data

Stroke adjustment

Y-stroke:

Once the HSP has been mounted, the Y-strokes of the pick position and place position can be set independently of each other.

Z-stroke:

Differences in height, for example between a rotary indexing table and a transfer system, can be compensated after mounting.

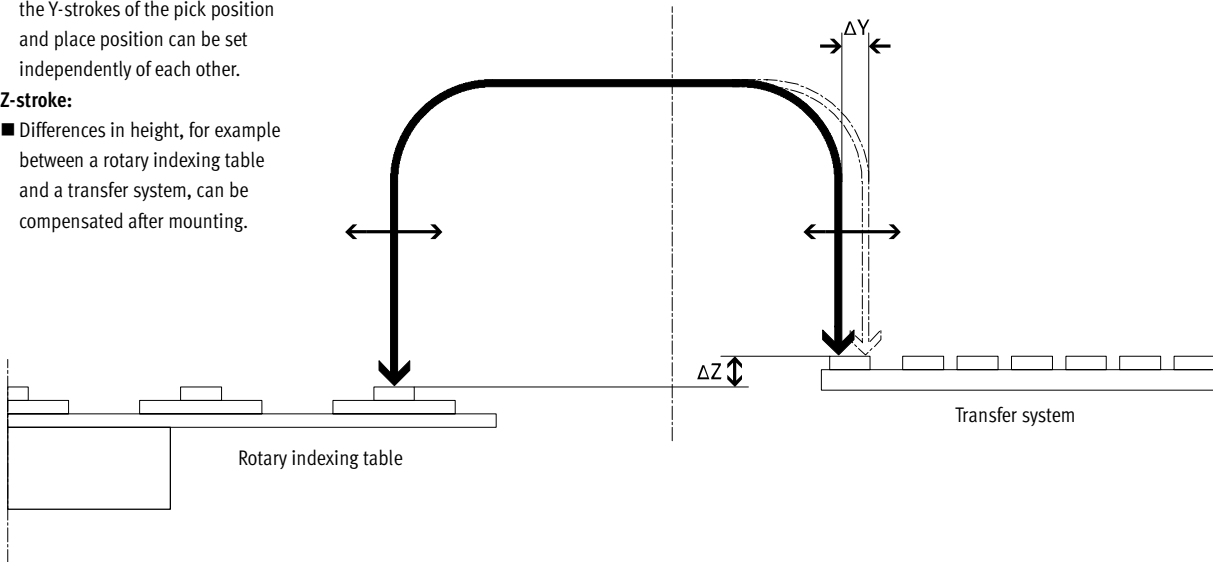

Y-axis (horizontal)

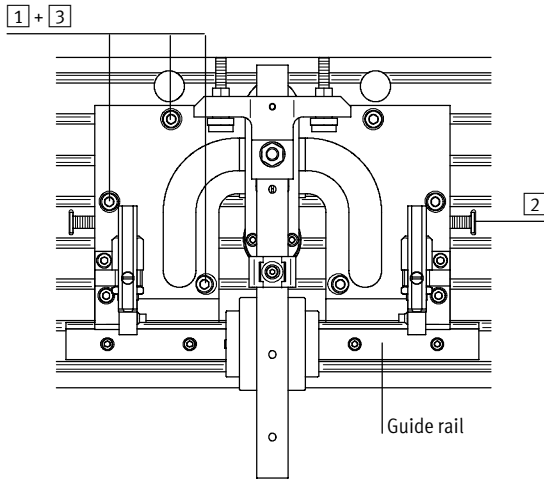

Procedure:

- 1 Loosen the screws
- 2 Adjust the slotted guide plate using the adjustment screw (the slotted guide plate must always make contact with the guide rail)
- 3 Tighten the screws

Z-axis (vertical)

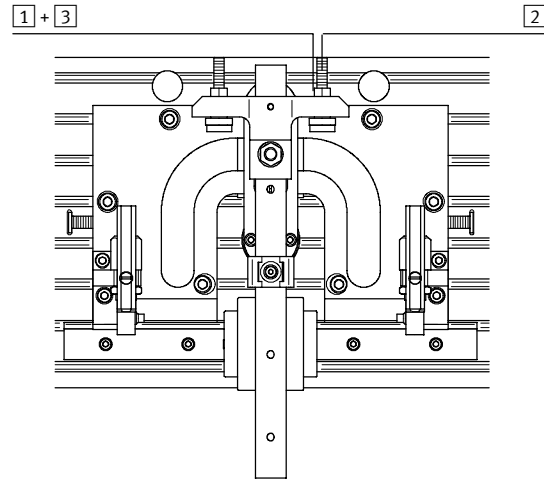

Procedure:

- 1 Loosen the lock nuts
- 2 Set the desired Z-stroke using the set screw
- 3 Tighten the lock nuts

Handling module HSP

Technical data

Materials

Sectional view

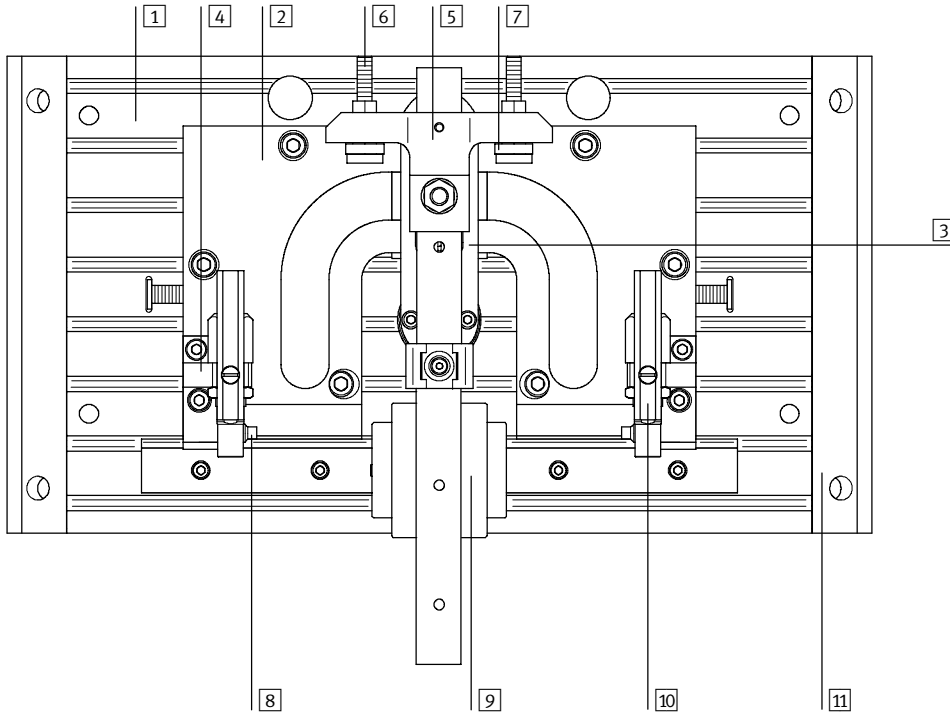

Type	HSP-...
1 Mounting plate	Wrought aluminium alloy, anodised
2 Slotted guide plate	Case-hardened steel, burnished
3 Swivel lever	Case-hardened steel, burnished
4 Retainer	Wrought aluminium alloy, anodised
5 Flange	Wrought aluminium alloy, anodised
6 Adjusting screw	High-alloy steel
7 Stop sleeve	High-alloy steel
8 Pressure piece	High-alloy steel
9 Cross-guide	Tempered steel
10 Sensor rail	Wrought aluminium alloy, anodised
11 Housing	Wrought aluminium alloy, anodised
Material note	Free of copper, PTFE and silicone

Type	HSP-...-AS-... (without drive)
Shaft	Steel
Bearings	Wrought aluminium alloy
Ball bearings	Rolled steel

Handling module HSP

Technical data

Materials

Sectional view of swivel module DSM

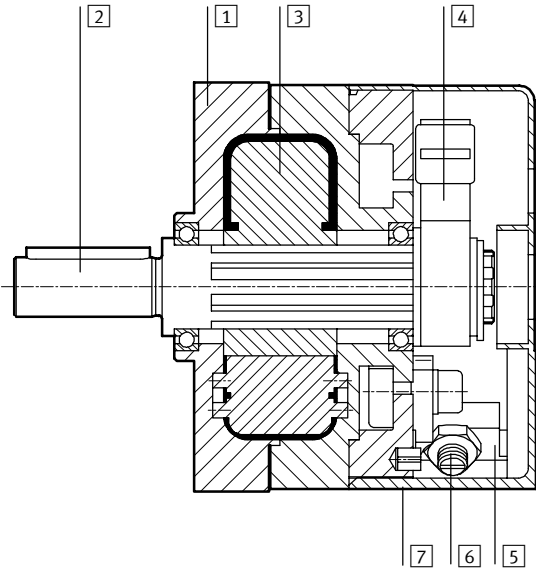

Type	DSM-...
1 Housing	Wrought aluminium alloy
2 Shaft	Steel with nickel plated surface
3 Rotary vane	Fibre glass reinforced plastic
4 Stop lever	Anodized aluminium
5 Stop/shock absorber retainer	Stainless steel
6 Stop screw	Stainless steel
7 Protective cover	Fibre glass reinforced plastic
- Seals	Polyurethane
Material note	Free of copper, PTFE and silicone

Handling module HSP

Technical data

Dimensions

Download CAD data → www.festo.com/en/engineering

HSP with swivel module DSM

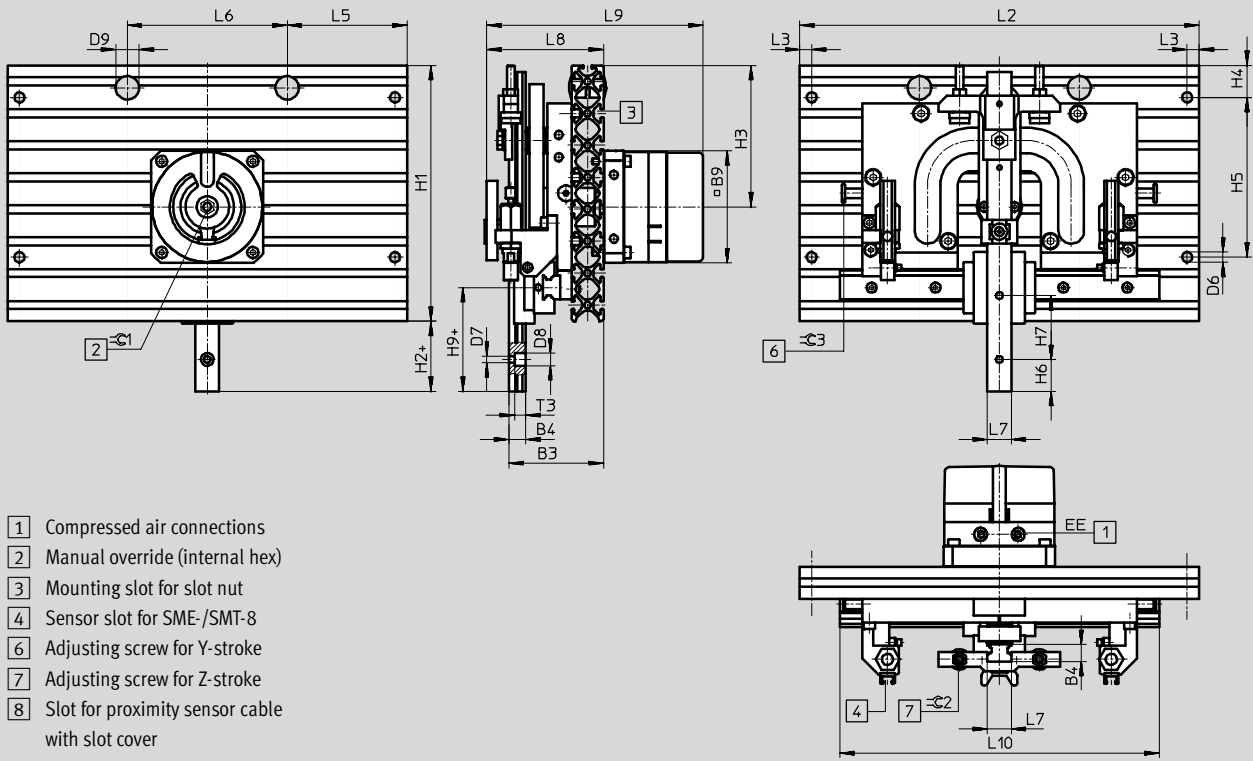

- 1 Compressed air connections
- 2 Manual override (internal hex)
- 3 Mounting slot for slot nut
- 4 Sensor slot for SME-/SMT-8
- 6 Adjusting screw for Y-stroke
- 7 Adjusting screw for Z-stroke
- 8 Slot for proximity sensor cable with slot cover

HSP with swivel module DSM and protective cover

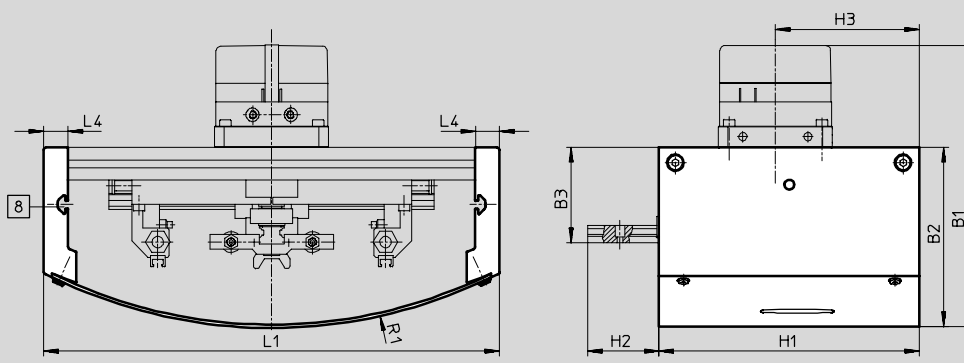

Handling module HSP

Technical data

Dimensions Download CAD data → www.festo.com/en/engineering

HSP without drive

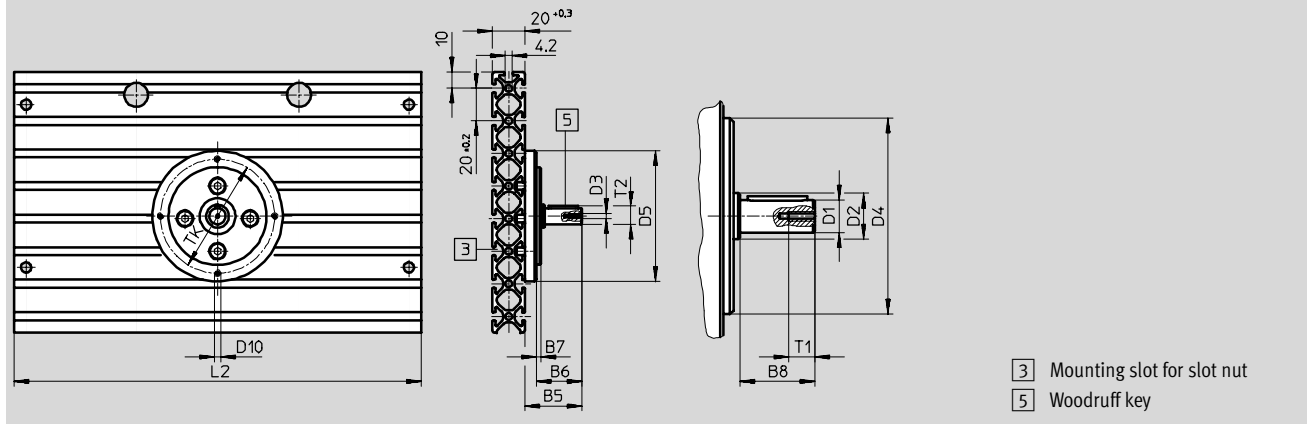

- 3 Mounting slot for slot nut
- 5 Woodruff key

Dimensions Download CAD data → www.festo.com/en/engineering

HSP with wait position module on right

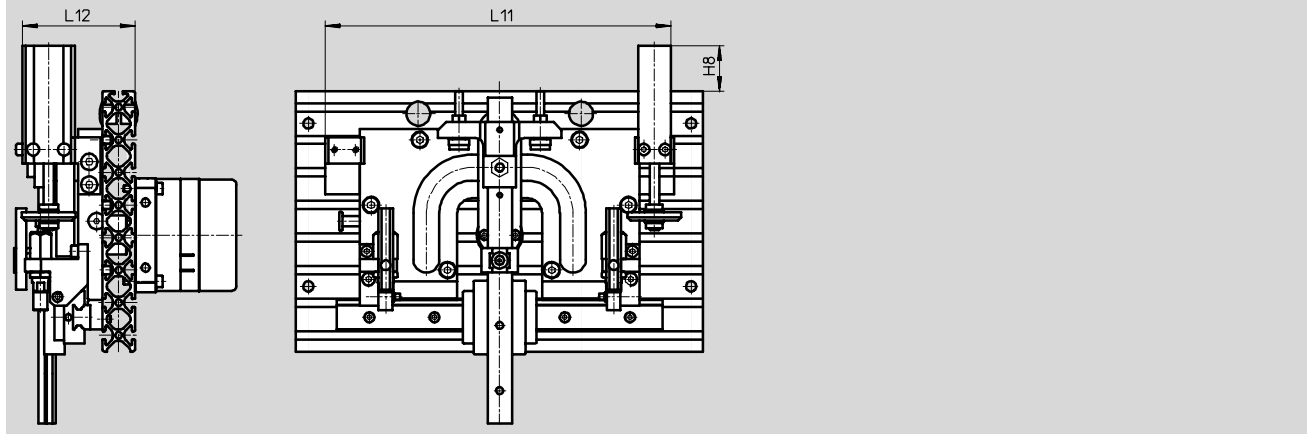

Size	B1	B2	B3	B4	B5	B6	B7	B8	B9	L1	L2	L3	L4	L5	L6	L7
[mm]	±3	±2	±0.5							±0.6	±0.2					
12	146	93	56	9 ^{-0.03}	29	22	3	17.5	56	200	170	7.5	15	85	-	12 ^{-0.01/-0.05}
16	173	111	60	10.6 ^{-0.03}	35	28	3	23	70	280	250	7.5	15	75	100	15 ^{-0.01/-0.05}
25	184	115	62	10 ^{±0.05}	44	36	4	30	83	370	340	7.5	15	30	280	23.2 ^{±0.05}

Size	L8	L9	L10	L11 ¹⁾	L12	D1	D2	D3	D4	D5	D6	D7	D8	D9	D10	EE
[mm]	±1.2	±2.8				∅ g7	∅	∅	∅ f8	∅	∅	∅	∅	∅		
12	65	118	150	141.5	64	8	12.5	M3	45	65	6.3	3.5	6.2	13	M4	M5
16	73	136	200	210	69	10	14	M3	60	80	6.3	4.3	8	13	M4	M5
25	80	136	250	277	79	12	17	M4	70	95	6.3	4.5	10	13	M5	M5

Size	H1	H2	H3	H4	H5	H6	H7	H8	H9	R1	T1	T2	T3	TK	⊖C1	⊖C2	⊖C3 Woodruff key to DIN 6885
[mm]					±0.2							max.		±0.1			
12	120	34	66	40	40	12.5	25	30	44	200	9	8.8	6	55	6	2	3 A2x2x12
16	160	44	88.5	20	100	20	40	33	65	306	9	11.2	6.5	70	8	2.5	3 A3x3x18
25	200	75	110	40	100	20	30	13	101	484	10	13.5	6.3	82	8	2.5	4 A4x4x25

1) If the Y-stroke is increased, the change in stroke must be added to the dimension.

Handling module HSP

Technical data

Dimensions

Download CAD data → www.festo.com/en/engineering

Adapter kit HAPG-70/-71/-72

HAPG-70

HAPG-71/72

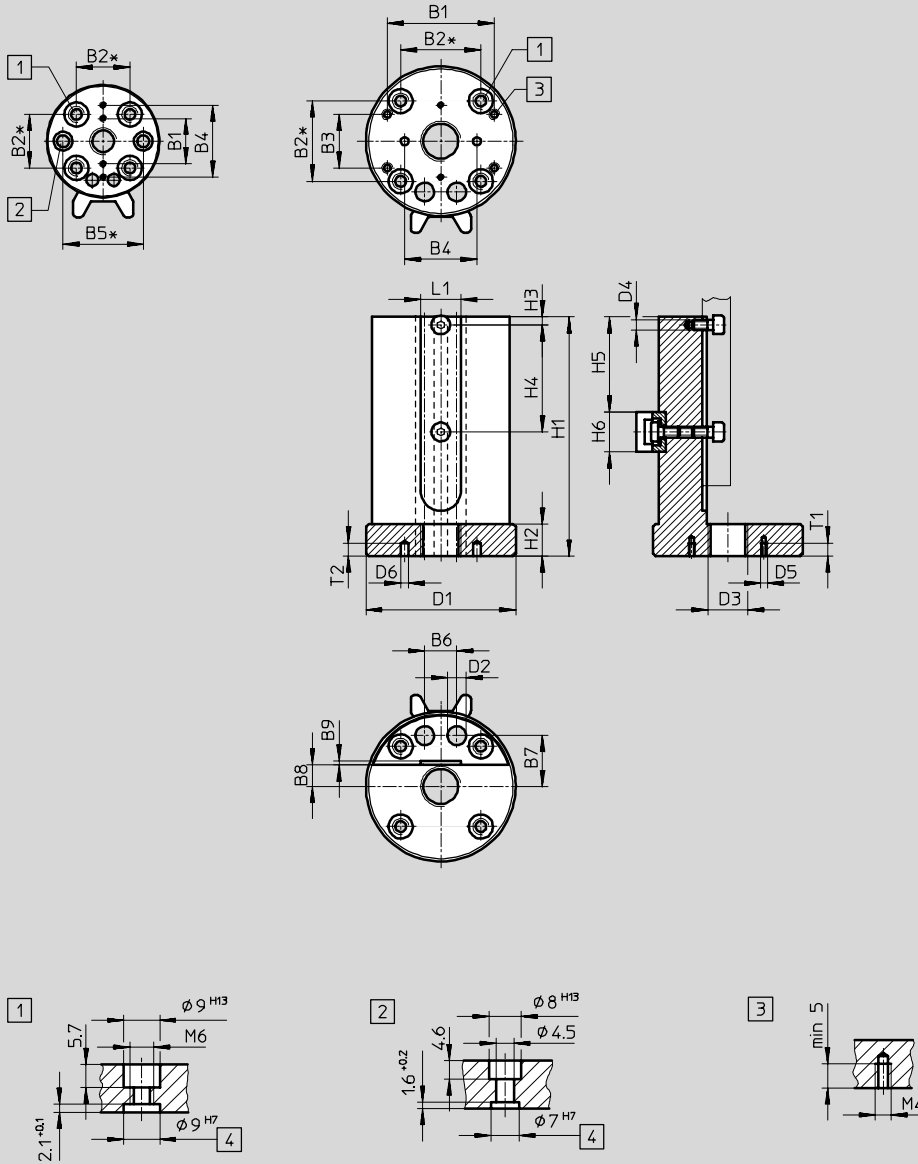

4 Hole for centring sleeve ZBH and mounting thread

Type	B1	B2*	B3	B4	B5*	B6	B7	B8	B9	D1	D2	D3
	±0.1	±0.1	±0.1	±0.1	±0.1				+0.2	∅	∅	
HAPG-70	10	20	-	27	30	8	14.5	5	1	42	4.5	M10x1
HAPG-71	40	30	20	27	-	12	19	8	1.5	56	7	M15x1
HAPG-72	40	30	20	27	-	12	19	8	1.5	56	7	M15x1

Type	D4	D5	D6	H1	H2	H3	H4	H5	H6	L1	T1	T2
			∅ H7				±0.1		+0.2	+0.1	min.	min.
HAPG-70	M3	M2.5	-	70	12	5	25	22.5	15	12	5	-
HAPG-71	M4	M2.5	3	89.5	12	3	40	35.5	15	15	5	5
HAPG-72	M4	M2.5	3	89.5	12	13	30	35.5	15	23.2	5	5

* Tolerance for centring hole ±0.02

Handling module HSP

Technical data

Ordering data						
Size [mm]	12		16		25	
	Part No.	Type	Part No.	Type	Part No.	Type
With swivel module	533 599	HSP-12-AP	533 607	HSP-16-AP	533 615	HSP-25-AP
With swivel module and protective cover	533 600	HSP-12-AP-SD	533 608	HSP-16-AP-SD	533 616	HSP-25-AP-SD
With swivel module, protective cover and wait position module on right	533 601	HSP-12-AP-SD-WR	533 609	HSP-16-AP-SD-WR	533 617	HSP-25-AP-SD-WR
With swivel module, protective cover and wait position module on left	533 602	HSP-12-AP-SD-WL	533 610	HSP-16-AP-SD-WL	533 618	HSP-25-AP-SD-WL
With swivel module and wait position module on right	533 603	HSP-12-AP-WR	533 611	HSP-16-AP-WR	533 619	HSP-25-AP-WR
With swivel module and wait position module on left	533 604	HSP-12-AP-WL	533 612	HSP-16-AP-WL	533 620	HSP-25-AP-WL
Without drive	533 605	HSP-12-AS	533 613	HSP-16-AS	533 621	HSP-25-AS
With drive, with protective cover	533 606	HSP-12-AS-SD	533 614	HSP-16-AS-SD	533 622	HSP-25-AS-SD

Mounting adapter kit HAPG-70/-71/-72 on HSP

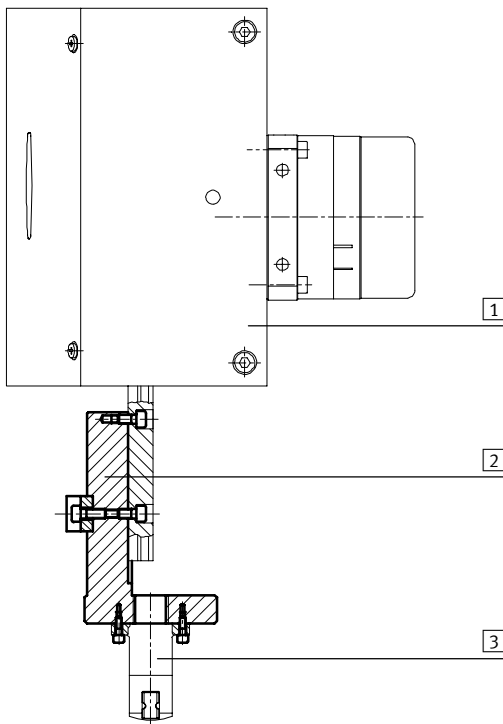

- 1 Handling module HSP
- 2 Adapter kit HAPG
- 3 Gripper

Handling module HSP

Accessories

Adapter kit HAPG

Material:
Wrought aluminium alloy, anodised



Dimensions → 1 / 7.2-16

Ordering data				
For size	Weight	Part No.	Type	
			[g]	
12	75	533 629	HAPG-70	
16	170	533 630	HAPG-71	
25	170	533 631	HAPG-72	

7.2

Installation kit MKRP

Material:
Conduit/fitting: Polyamide
Reducer/lock nut:
Nickel plated brass
Adapter plate/bracket:
Powder-coated steel

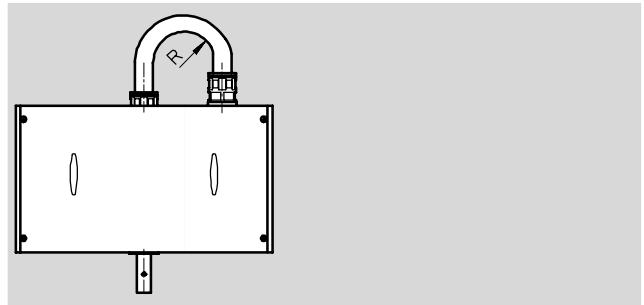

Ordering data				
For size	Max. bending radius for conduit ¹⁾	Weight	Type	
			Part No.	Type
R		[g]		
12	55	150	533 632	MKRP-1
16	75	160	533 633	MKRP-2
25	75	160	533 634	MKRP-3

1) The conduit must not be filled beyond 70%.

Handling module HSP

Accessories

Cover kit BSD-HSP

Material:
Wrought aluminium alloy, anodised



Dimensions → 1 / 7.2-14

Ordering data			
For size	Weight	Part No.	Type
	[g]		
12	825	533 635	BSD-HSP-12
16	1350	533 636	BSD-HSP-16
25	1770	533 637	BSD-HSP-25

Wait position module BWL-/BWR-HSP

Material:
Wrought aluminium alloy, anodised



Dimensions → 1 / 7.2-15

Ordering data			
For size	Wait position	Weight	Part No. Type
		[g]	
12	on right	75	533 623 BWR-HSP-12
	on left	75	533 624 BWL-HSP-12
16	on right	135	533 625 BWR-HSP-16
	on left	135	533 626 BWL-HSP-16
25	on right	275	533 627 BWR-HSP-25
	on left	275	533 628 BWL-HSP-25

Handling module HSP

Accessories

Adapter kits for grippers

For combination of HSP with grippers HGD/HGW/HGR/HGP/HGPP/HGWM/HGPM or semi-rotary drive DRQD

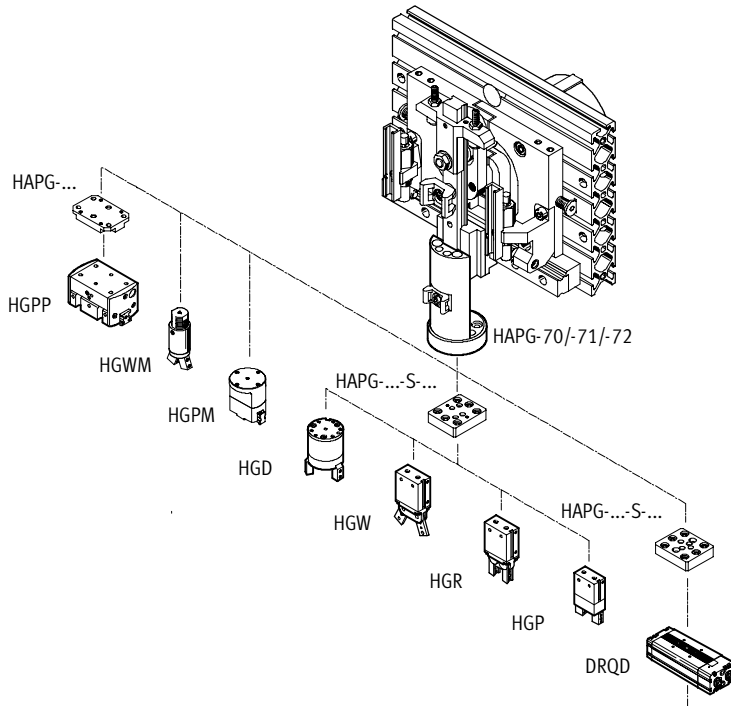

Gripper		Adapter kit		Required mounting components	B1	D1	D2	H1	L1
Part No.	Type	Part No.	Type						
HSP-12-... with HAPG-70									
197 561	HGPM-08-E0-G9	-		M2.5 x 8 (2x)	-				
197 564	HGPM-08-EZ-G9	-		M2.5 x 8 (2x)	-				
197 567	HGPM-12-E0-G9	-		M2.5 x 10 (2x)	-				
197 570	HGPM-12-EZ-G9	-		M2.5 x 10 (2x)	-				
185 694	HGWM-08-E0-G7	-		-	-				
185 697	HGWM-08-EZ-G7	-		-	-				
1)	DRQD-6-...	-		M4 x 20 ²⁾	-				
174 815	HGP-06-A	192 709	HAPG-60-S1	-	12	M3	M5	30	30
174 817	HGR-10-A								
174 818	HGW-10-A								
HSP-16-... with HAPG-71									
197 567	HGPM-12-E0-G9	-		M2.5 x 10 (2x)	-				
197 570	HGPM-12-EZ-G9	-		M2.5 x 10 (2x)	-				
185 700	HGWM-12-E0-G7	-		-	-				
185 703	HGWM-12-EZ-G7	-		-	-				
174 815	HGP-06-A	192 706	HAPG-37-S1	-	12	M3	M5	42	50
174 817	HGR-10-A								
174 818	HGW-10-A								
1)	DRQD-8-...								
174 819	HGD-16-A	192 705	HAPG-36-S1	-	12	M3	M5	42	50
197 542	HGP-10-A-B								
161 829	HGR-16-A								
161 833	HGW-16-A								
525 658	HGPP-10-A			529 017	HAPG-57	-	8	M3	M4
187 867	HGPP-12-A	-	12			M3	M5	52	44

1) The semi-rotary drive DRQD is a modular product that can be configured and ordered via www.festo.com
 1) The semi-rotary drive DRQD is a modular product, for information on configuration and ordering → 1 / 4.2-23
 2) The scope of delivery for the DRQD includes two centring sleeves.

Handling module HSP

Accessories

Gripper		Adapter kit		Required mounting components	B1	D1	D2	H1	L1
Part No.	Type	Part No.	Type						
HSP-25-... with HAPG-72									
197 567	HGPM-12-EO-G9	-	-	M2.5 x 10 (2x)	-	-	-	-	-
197 570	HGPM-12-EZ-G9	-	-	M2.5 x 10 (2x)	-	-	-	-	-
185 700	HGWM-12-EO-G7	-	-	-	-	-	-	-	-
185 703	HGWM-12-EZ-G7	-	-	-	-	-	-	-	-
174 819	HGD-16-A	192 705	HAPG-36-S1	-	12	M3	M5	42	50
197 542	HGP-10-A-B	193 921	HAPG-36-S3	-	12	M3	M5	42	50
161 829	HGR-16-A								
161 833	HGW-16-A								
197 545	HGP-16-A-B	193 922	HAPG-37-S4	-	12	M4	M5	42	50
161 830	HGR-25-A								
161 834	HGW-25-A								
¹⁾	DRQD-12-...								
¹⁾	DRQD-16-...	192 707	HAPG-38	-	12	M5	M4	50	71
525 658	HGPP-10-A	529 017	HAPG-57	-	8	M3	M4	33	49.6
187 867	HGPP-12-A	-	-	-	12	M3	M5	52	44
187 870	HGPP-16-A	191 901	HAPG-55	-	10	M3	M5	40	62

1) The semi-rotary drive DRQD is a modular product that can be configured and ordered via www.festo.com
 1) The semi-rotary drive DRQD is a modular product, for information on configuration and ordering → 1 / 4.2-23

Handling units
Handling modules

7.2

Adapter kit HAPG-36/-37/-60

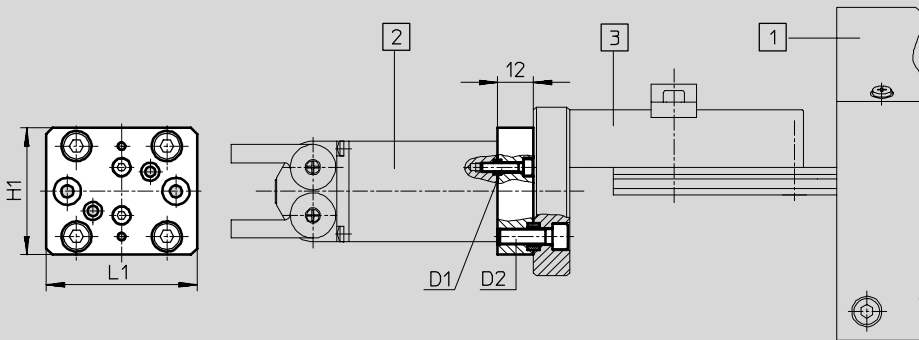

- 1 Handling module HSP
- 2 Standard gripper HG...
- 3 Adapter kit HAPG



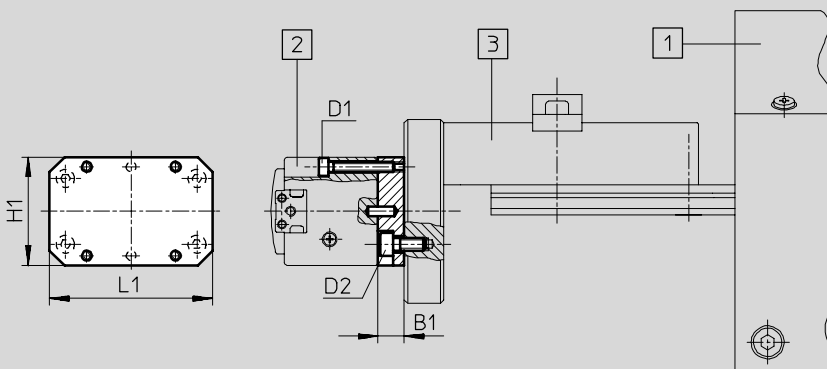







Adapter kit HAPG-38/-55/-57















- 1 Handling module HSP
- 2 Precision gripper HGPP
- 3 Adapter kit HAPG

Handling module HSP

Accessories

Ordering data – Proximity sensor for slot type 8, magneto-resistive							Technical data → 1 / 10.2-13		
	Mounting	Switch output	Electrical connection			Cable length [m]	Part No.	Type	
			Cable	M8 plug	M12 plug				
NO contact									
	Insertable from above	PNP	3-wire	–	–	2.5	525 898	SMT-8F-PS-24V-K2,5-OE	
		NPN		–	–		525 909	SMT-8F-NS-24V-K2,5-OE	
		–	2-wire	–	–	2.5	525 908	SMT-8F-ZS-24V-K2,5-OE	
		PNP	–	3-pin	–	0.3	525 899	SMT-8F-PS-24V-K0,3-M8D	
		NPN			–		525 910	SMT-8F-NS-24V-K0,3-M8D	
		PNP	–	–	3-pin	0.3	525 900	SMT-8F-PS-24V-K0,3-M12	
	Insertable, flush with the cylinder profile	PNP	3-wire	–	–	2.5	175 436	SMT-8-PS-K-LED-24-B	
		–	3-pin	–	–	0.3	175 484	SMT-8-PS-S-LED-24-B	
NC contact									
	Insertable from above	PNP	3-wire	–	–	7.5	525 911	SMT-8F-PO-24V-K7,5-OE	

Ordering data – Proximity sensor for slot type 8, magnetic reed							Technical data → 1 / 10.2-16		
	Mounting	Electrical connection			Cable length [m]	Part No.	Type		
		Cable	M8 plug						
NO contact									
	Insertable from above	3-wire		–	2.5	525 895	SME-8F-DS-24V-K2,5-OE		
		2-wire		–	5.0	525 897	SME-8F-DS-24V-K5,0-OE		
		–		3-pin	–	2.5	525 907	SME-8F-ZS-24V-K2,5-OE	
		–		3-pin	–	0.3	525 896	SME-8F-DS-24V-K0,3-M8D	
	Insertable, flush with the cylinder profile	3-wire		–	2.5	150 856	SME-8-K-LED-24		
		–		3-pin	–	0.3	150 857	SME-8-S-LED-24	
NC contact									
	Insertable from above	3-wire		–	7.5	525 906	SME-8F-DO-24V-K7,5-OE		

Ordering data – Plug sockets							Technical data → 1 / 10.2-100	
	Mounting	Switch output		Connection	Cable length [m]	Part No.	Type	
		PNP	NPN					
Straight socket								
	M8 union nut	■	■	3-pin	2.5	159 420	SIM-M8-3GD-2,5-PU	
					5	159 421	SIM-M8-3GD-5-PU	
	M12 union nut	■	■	3-pin	2.5	159 428	SIM-M12-3GD-2,5-PU	
					5	159 429	SIM-M12-3GD-5-PU	
Angled plug socket								
	M8 union nut	■	■	3-pin	2.5	159 422	SIM-M8-3WD-2,5-PU	
					5	159 423	SIM-M8-3WD-5-PU	
	M12 union nut	■	■	3-pin	2.5	159 430	SIM-M12-3WD-2,5-PU	
					5	159 431	SIM-M12-3WD-5-PU	

Ordering data – Slot cover for slot type 8				
	Mounting	Length [m]	Part No.	Type
	Insertable from above	2x 0.5	151 680	ABP-5-S

 Core Range

Handling module HSP

Accessories

Ordering data – One-way flow control valves				Technical data → Band 2	
	Connection		Material	Part No.	Type
	Thread	for tubing O.D.			
	M5	3	Metal design	193 137	GRLA-M5-QS-3-D
		4		193 138	GRLA-M5-QS-4-D
		6		193 139	GRLA-M5-QS-6-D

Slot nut for sub-base				
	Mounting		Part No.	Type
	Insertable from above		189 654	HMBN-5-M5

