

Linear modules HMP

FESTO



- Precision backlash-free guide system
- Infinitely adjustable end stops
- Adjustable end-position cushioning

Linear modules HMP

Key features

Key features at a glance

 **New**

- Sturdier
- Optimized end stop system
- Minimized susceptibility to wear
- One-way flow control valves that can be externally adjusted
- Integrated sensor strip

- Diameter of 16 ... 32 mm
- Stroke lengths of 50 ... 400 mm
- Extremely rigid basic profile
- Infinitely adjustable end stops
- Rotatable yoke plate
- Integrated clamping unit
- Precision backlash-free guide system

- Adjustable end-position cushioning
- Integrated sensors:
 - Sensor strip for proximity sensors for end-position sensing
 - Mounting slot for proximity sensors for position sensing
- Functional end cap
 - Pneumatic interface
 - Electrical interface

- Highly flexible thanks to various mounting and assembly options:
 - Basic profile
 - Yoke plate
- Large selection of adapters for:
 - Drive units
 - Grippers
- Innovative and user-friendly installation system

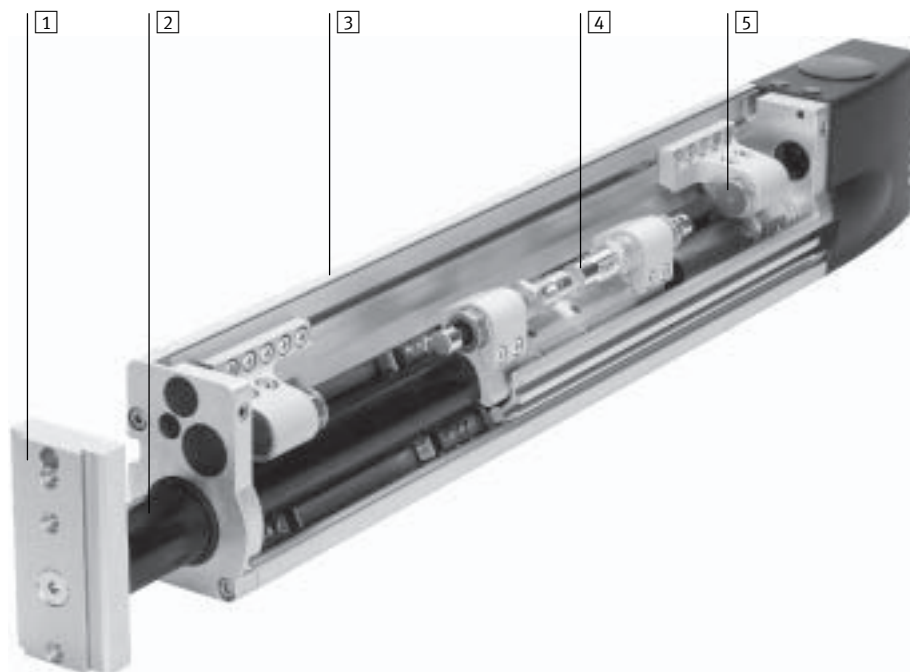

1 Yoke plate
Can be turned to any angle from 0 to 360°. The yoke plate cannot be turned if combined with the clamping unit. Drives and grippers can be mounted on the yoke plate by means of adapter kits (direct mounting or dovetail connections).

2 Guide system
Extremely high rigidity thanks to the hardened steel guide barrel which is supported in pre-tensioned and backlash-free recirculating ball bearing guides guaranteeing the utmost precision.

3 Basic profile
Drives and basic components can be attached to the rigid light alloy profile using adapter, connector and component kits.

4 End-position cushioning
Extremely dynamic operation thanks to hydraulic shock absorbers which cushion the piston sleeve at the end positions.

5 End stop
Any desired intermediate position can be set between minimum and maximum stroke (plus the strokes of the shock absorbers).

Linear modules HMP

Key features

Wide choice of variants

End stop

The optimized end stop system is practically wear-free. Rough adjustment by moving the stop into the profile groove. Fine adjustment using compressed air via a rotatable sleeve.

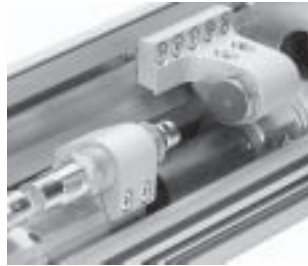

Clamping unit

The pneumatically-powered clamping unit can be used to hold loads at any end position and with the module installed at any angle. In the case of a pressure drop or pressure failure, the clamping unit acts like an EMERGENCY STOP device. The clamping unit can be released by means of the manual override.



End cap



Connections can be made on the top and bottom of the end cap. Pneumatic tubing and electrical cables can be bundled and routed through the end cap and conduits.

Max. 6 proximity sensors can be connected to the integral terminal strip. The switching states of the proximity sensors are indicated via a display window in the end cap.

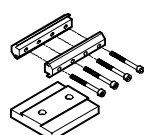

Mounting and assembly options

Mounting options

	<p>Dovetail mounting using connecting kit HAVB</p> 	<p>Direct mounting using screws and slot nuts NST</p> 	<p>Direct mounting using screws and centring sleeves ZBH</p> 
--	--	---	--

Mounting surfaces

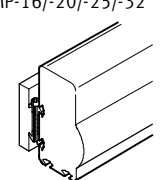
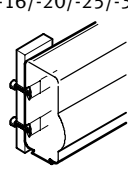
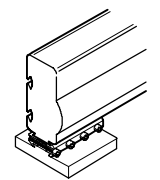
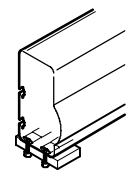
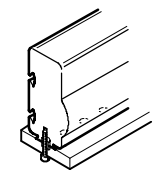
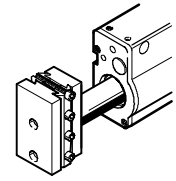
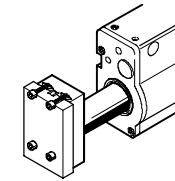
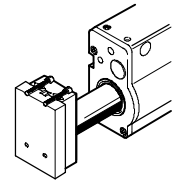
On the side of the basic profile	HMP-16/-20/-25/-32 	HMP-16/-20/-25/-32 	
On the underside of the basic profile	HMP-16/-20/-25/-32 	HMP-25/-32 	HMP-16/-20 
On the yoke plate	HMP-16/-20/-25/-32 	HMP-25/-32 	HMP-16/-20/-25/-32 

Linear modules HMP

System example

System product for handling and assembly technology

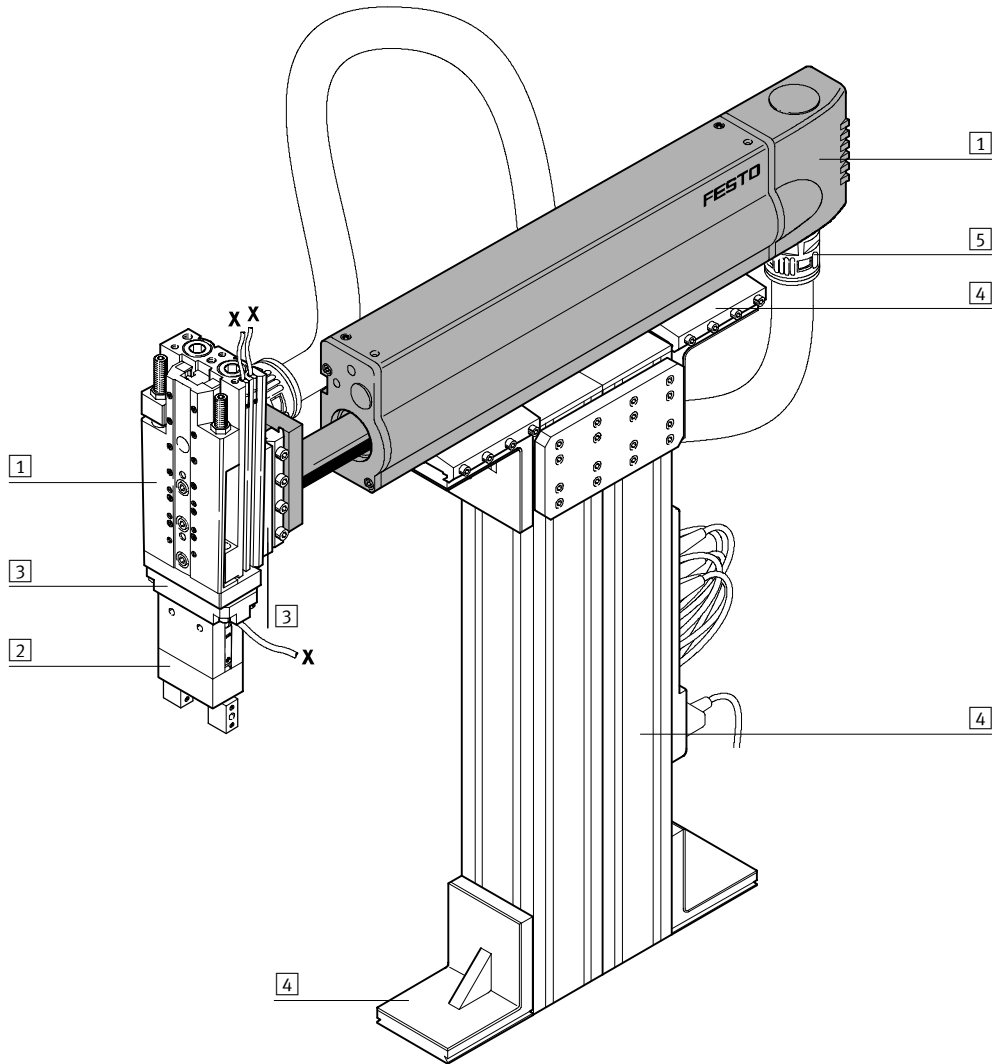

System elements and accessories		
	Brief description	→ Page
1	Drive units	Wide range of combination options within handling and assembly technology Volume 1
2	Grippers	Wide choice of variants within handling and assembly technology Volume 1
3	Adapters	For drive/drive and drive/gripper combinations Volume 5
4	Basic mounting components	Profiles and profile connectors as well as profile/drive connectors Volume 5
5	Installation components	For achieving a clear-cut, safe layout for electrical cables and tubing Volume 5
-	Axes	Wide range of combination options within handling and assembly technology Volume 5
-	Motors	Servo and stepper motors, with or without gearing Volume 5

Linear modules HMP

Peripherals overview

Peripherals overview

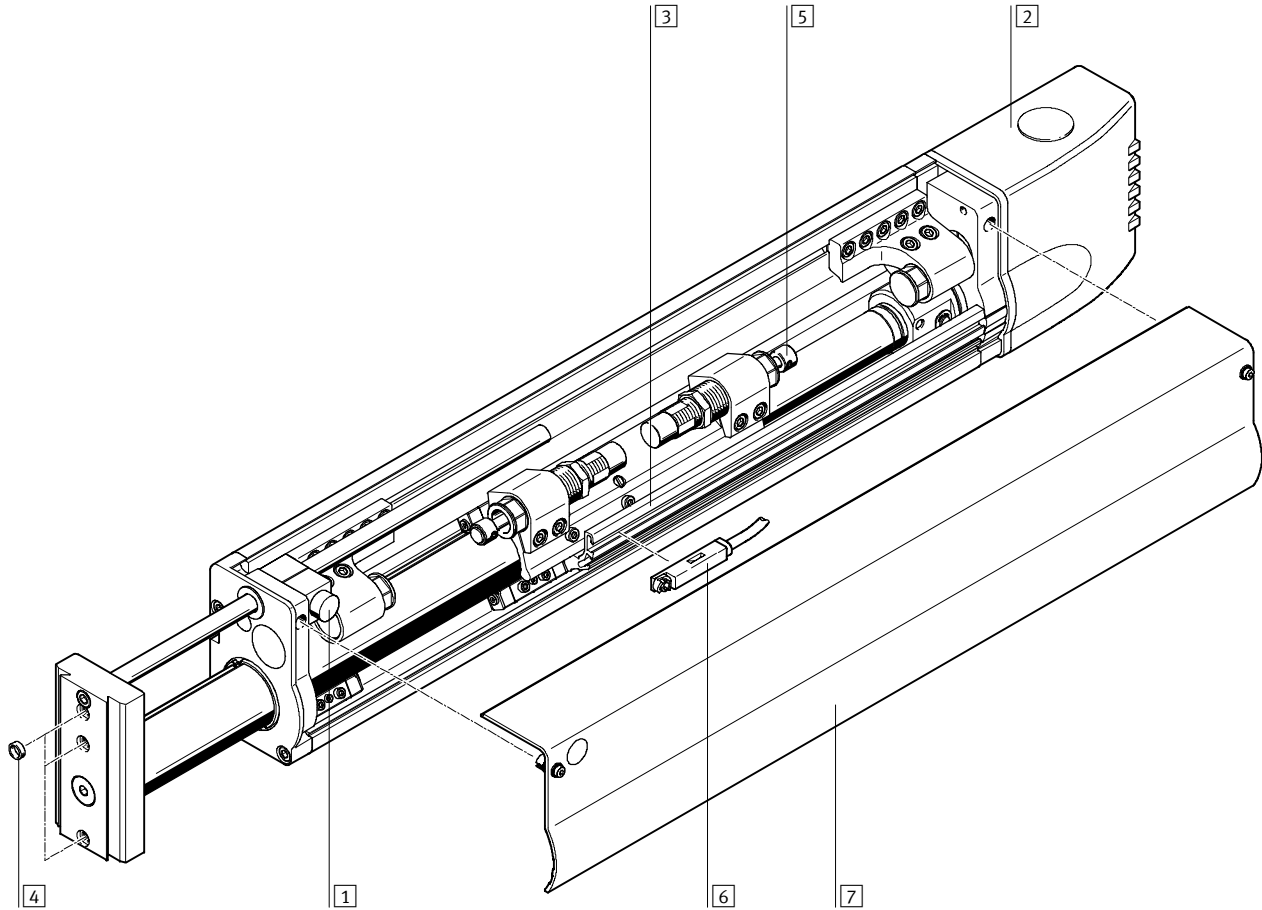

Accessories			
	Brief description	→Page	
1	Clamping unit KP	For holding loads in all mounting and end positions in the event of a drop in pressure	1 / 7.1-20
2	End cap AD/EL	The end cap (EL) houses an integrated electrical interface	1 / 7.1-20
3	Sensor strip SL	For mounting proximity sensors and flexible sensing of any desired end positions. Included in the scope of delivery of the linear module.	1 / 7.1-20
4	Centring sleeve Z	For centring loads and attachments on the yoke plate	1 / 7.1-22
5	Shock absorber	Included in the scope of delivery of the linear module	1 / 7.1-22
6	Proximity sensor A...	For position sensing via the sensor strip	1 / 7.1-23
7	Housing cover	Included in the scope of delivery of the linear module	-
-	Plug socket with cable V	For proximity sensors	1 / 7.1-23
-	Slot cover A	For the protection of proximity sensor cable	1 / 7.1-22

Linear modules HMP

Type codes

		HMP	-	16	-	150	-	B	-	SL	-	2G3	-	KP	-	EL	-	A1	-	E	
Type																					
HMP	Linear module																				
Piston Ø [mm]																					
Stroke [mm]																					
Generation																					
B	B series																				
Sensing																					
SL	Sensor strip																				
Pneumatic connection																					
2G3	For 3 mm I.D. tubing																				
2G4	For 4 mm I.D. tubing																				
2G6	For 6 mm I.D. tubing																				
Clamping unit																					
KP	Clamping cartridge																				
Interface																					
AD	End cap																				
EL	End cap with electrical interface																				
Proximity sensor																					
A1	With cable 2.5 m																				
A2	Contactless with cable, 2.5 m, NPN																				
A3	Contactless with cable, 2.5 m, PNP																				
A4	With plug																				
A5	Contactless with plug, NPN																				
A6	Contactless with plug, PNP																				
User manual																					
E	English																				
S	Spanish																				
F	French																				
I	Italian																				
V	Swedish																				
B	Express waiver - no manual to be included (already available)																				

Linear modules HMP

Type codes

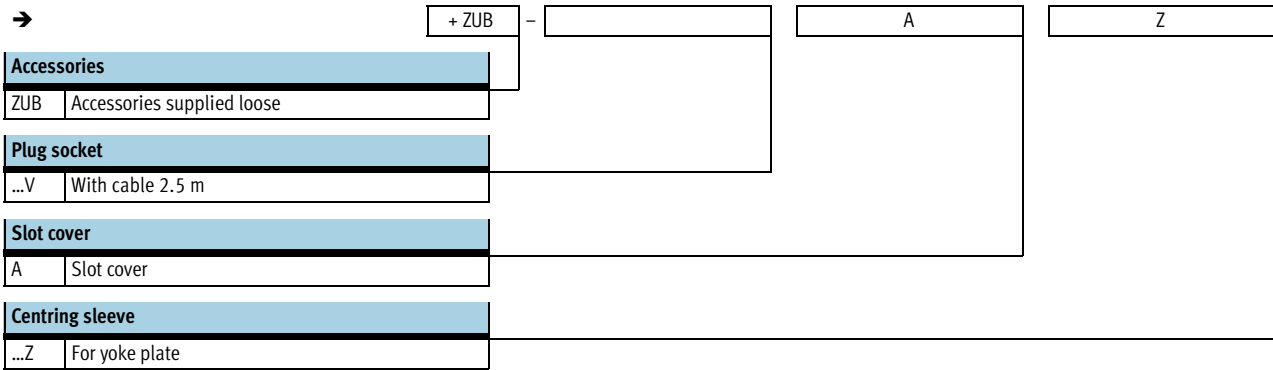

Linear modules HMP

Technical data



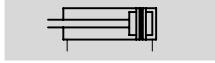

Function

Standard version

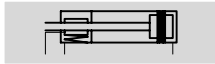

with clamping unit



 - Piston Ø
16 ... 32 mm

 - Stroke length
50 ... 400 mm

 - www.festo.com/en/Spare_parts_service



General technical data						
Piston Ø		16	20	25	32	
System mode		Yoke				
Mode of operation		Double-acting				
Protection against torsion		Guide				
Type of connection		Female thread				
Pneumatic connection		M5	G $\frac{1}{8}$	G $\frac{1}{8}$	G $\frac{1}{4}$	
Assembly position		Any				
Effective stroke	[mm]	16 ... 320	24 ... 400	24 ... 400	40 ... 400	
Position sensing		With proximity sensor				
Max. repetition accuracy ¹⁾	[mm]	0.01				
Max. speed	advancing	[m/s]	0.8	1.1	1.1	1.2
	retracting	[m/s]	0.8	1.1	1.1	1.1

1) Variation of end position for 100 successive strokes under constant operating conditions

Operating and environmental conditions					
Piston Ø		16	20	25	32
Operating pressure	[bar]	4 ... 8			
Operating medium		Dried compressed air, lubricated or unlubricated			
Ambient temperature ¹⁾	[°C]	0 ... +60			
Protection class to EN 60 529		IP 40			
Noise level F _{LEQ}	[dB(A)]	62	65	68	69
Corrosion resistance class CRC ²⁾		2			

1) Note operating range of proximity sensors

2) Corrosion resistance class 2 according to Festo standard 940 070

Components requiring moderate corrosion resistance. Externally visible parts with primarily decorative surface requirements which are in direct contact with a normal industrial environment or media such as coolants or lubricating agents.

Forces [N]					
Piston Ø		16	20	25	32
Theoretical force at 6 bar, advancing ¹⁾		121	188	295	483
Theoretical force at 6 bar, retracting ¹⁾		104	158	247	415

1) Theoretical values, please note: Degree of efficiency: approx. 90%

Linear modules HMP

Technical data

Weights [g]		16	20	25	32
Piston Ø					
Product weight	at 0 mm stroke	2,100	4,700	6,300	10,900
	Per 10 mm stroke	88	110	150	200
Moving load	at 0 mm stroke	900	1,500	2,300	4,000
	Per 10 mm stroke	28	37	55	74
End cap	HMP-...-AD	180	270	300	400
	HMP-...-EL	210	300	330	430
Clamping unit HMP-...-KP for effective stroke	50 mm	109	114	-	-
	100 mm	120	125	-	-
	150 mm	131	136	-	-
	200 mm	142	147	-	-
	250 mm	153	158	-	-
	320 mm	168	173	-	-
	400 mm	-	191	-	-

Materials

Sectional view

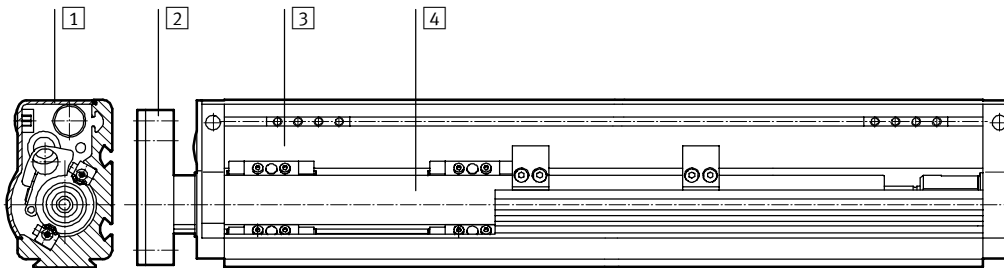

Linear module		
1	End cap	Anodised aluminium
2	Yoke plate	Anodised aluminium
3	Profile	Anodised aluminium
4	Guide barrel	Tool steel
-	Seals	Perbunan, polyurethane

Linear modules HMP

Technical data

Permissible torque M as a function of the stroke length l (at the yoke plate)

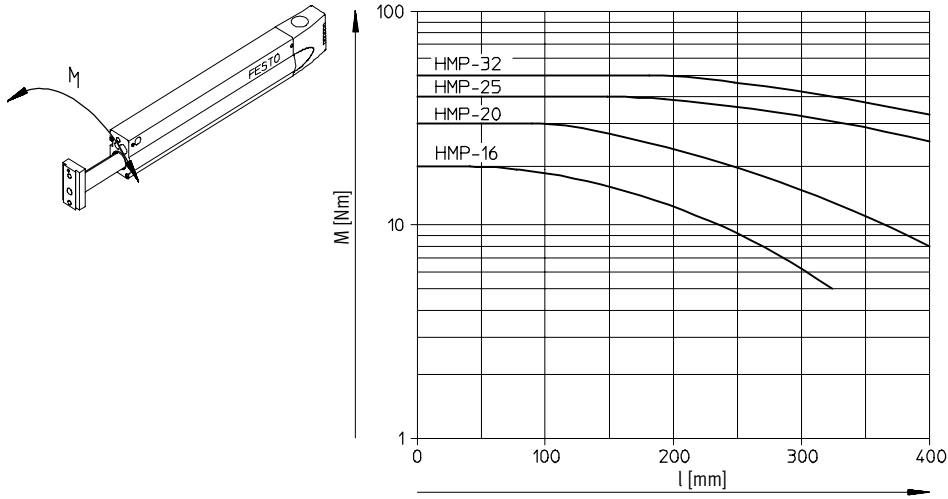

Permissible effective load Fq as a function of the stroke length l (at the front plate)

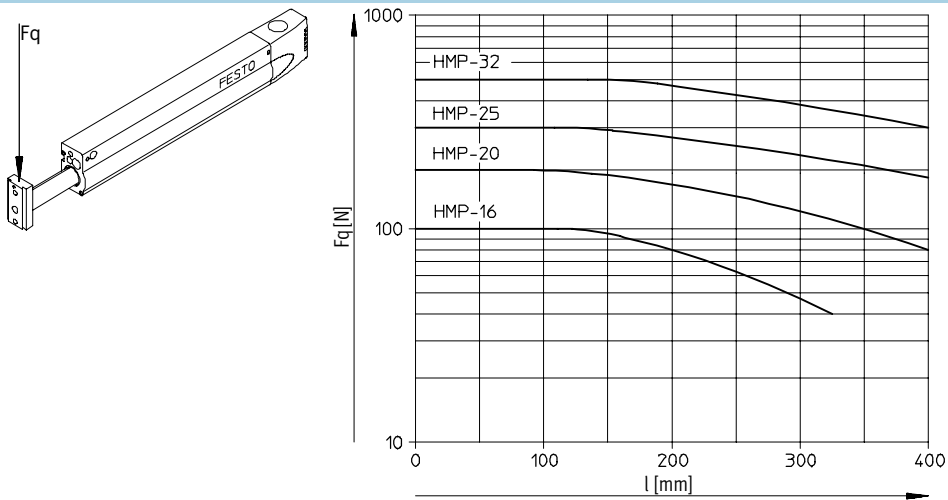

Linear modules HMP

Technical data

Deflection/deformation f as a function of the working load m and the position l (stroke)

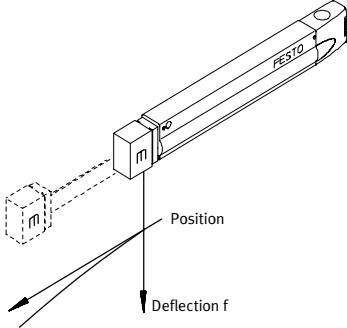

HMP-16

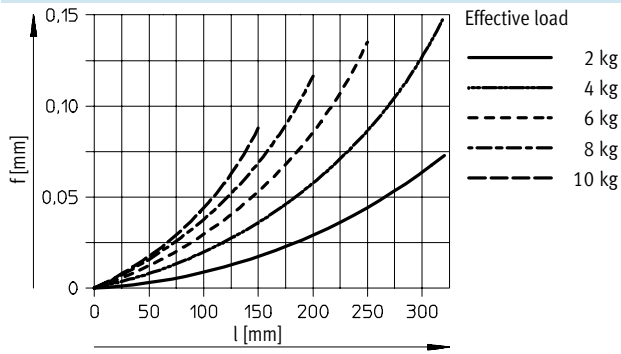

HMP-20

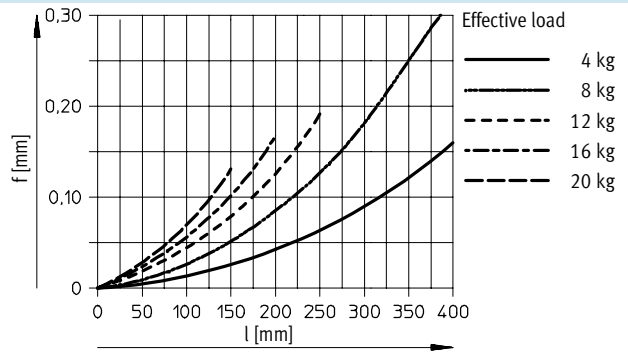

HMP-25

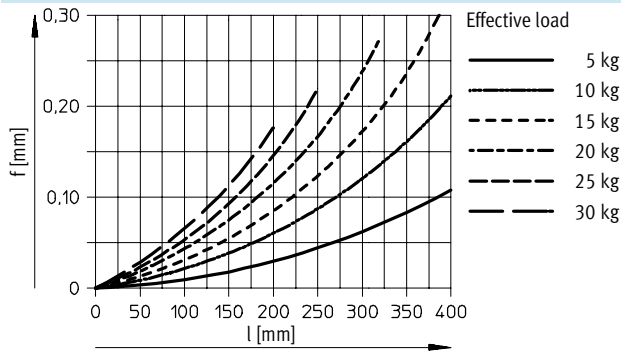

HMP-32

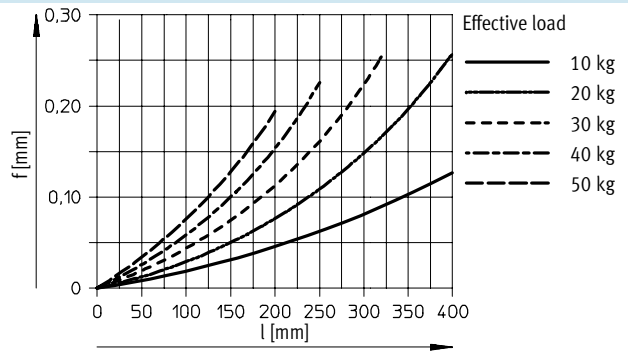

Linear modules HMP

Technical data

Max. permissible horizontal working load at 6 bar

- HMP-16: 10 kg
- HMP-20: 20 kg
- HMP-25: 30 kg
- HMP-32: 50 kg

Permissible horizontal advancing time t as a function of the stroke length and the working load m with optimum shock absorber stroke

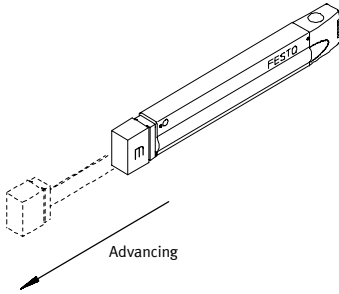

Handling units
Linear modules

7.1

HMP-16¹⁾

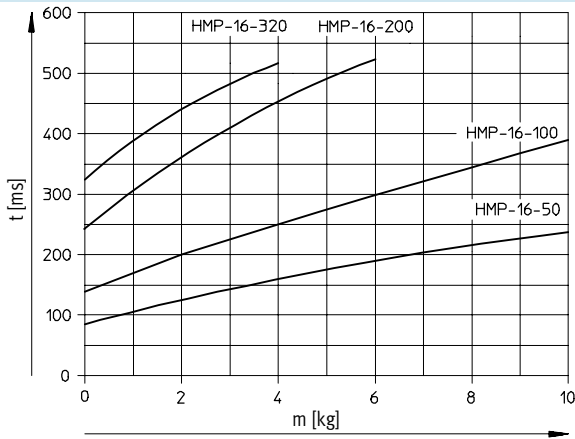

HMP-20¹⁾

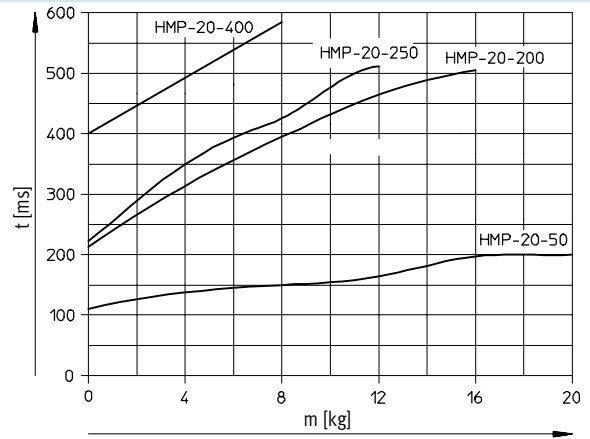

HMP-25¹⁾

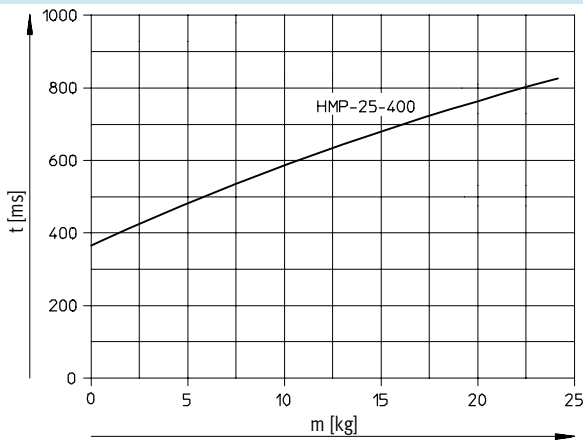

HMP-32¹⁾

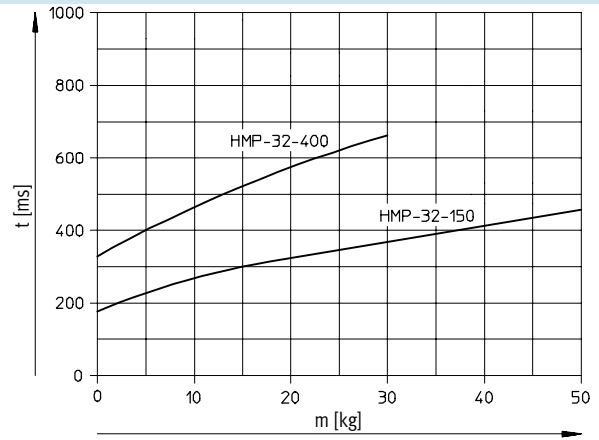

1) Further nominal strokes in preparation

Linear modules HMP

Technical data

Max. permissible horizontal working load at 6 bar

- HMP-16: 10 kg
- HMP-20: 20 kg
- HMP-25: 30 kg
- HMP-32: 50 kg

Permissible horizontal retracting time t as a function of the stroke length and the working load m with optimum shock absorber stroke

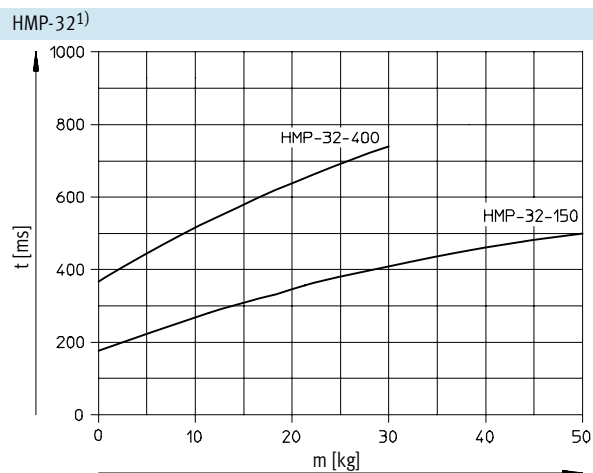
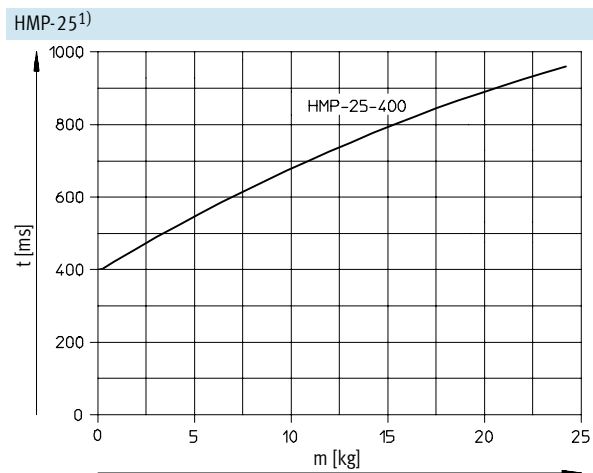
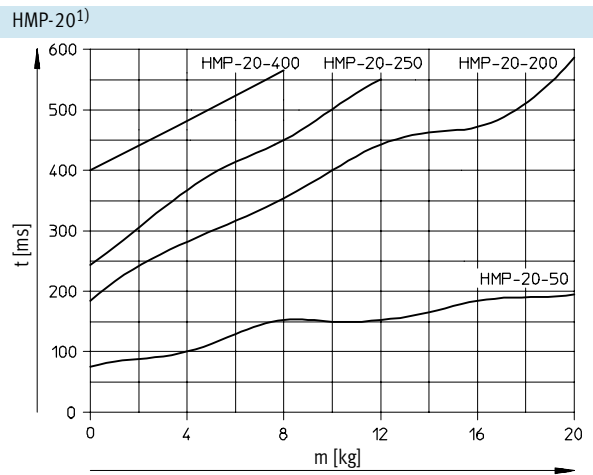
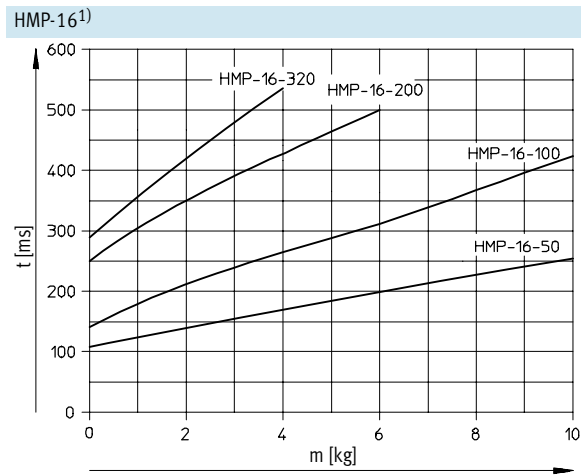
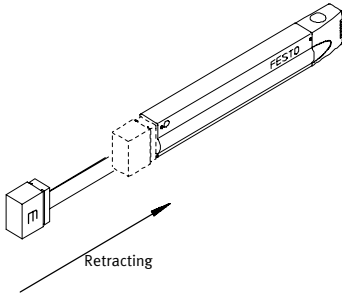

1) Further nominal strokes in preparation

Linear modules HMP

Technical data

Handling units
Linear modules

7.1

Max. permissible vertical working load at 6 bar

Without clamping cartridge	With clamping cartridge
HMP-16: 5 kg	HMP-16: 4 kg
HMP-20: 10 kg	HMP-20: 7.5 kg
HMP-25: 15 kg	
HMP-32: 25 kg	

Permissible vertical advancing time t as a function of the stroke length and the working load m with optimum shock absorber stroke

HMP-16/-20/-25/-32¹⁾

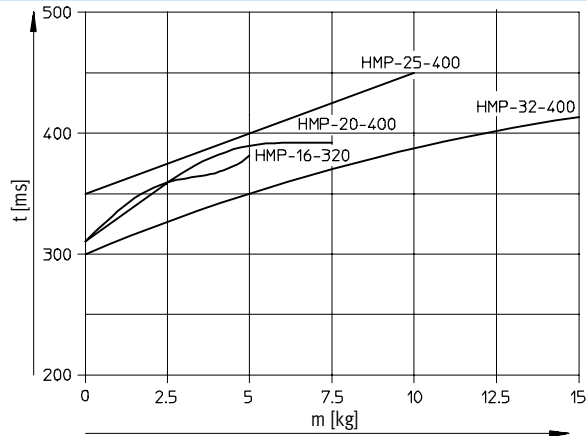
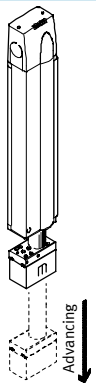

Permissible vertical retracting time t as a function of the stroke length and the working load m with optimum shock absorber stroke

HMP-16/-20/-25/-32¹⁾

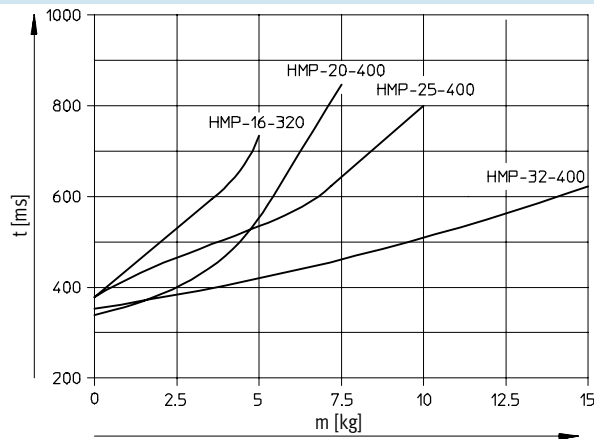
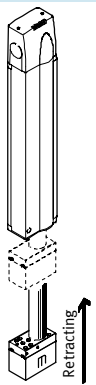

1) Further nominal strokes in preparation

Linear modules HMP

Technical data

Advancing/retracting time t as a function of the optimum length L to which the shock absorber should be screwed out

In order to obtain the shortest possible travel time with a linear module HMP, it is essential to adjust the shock absorbers to match the advance/retract stroke time t .

The optimum length L to which the shock absorbers should be screwed out is shown in the adjacent graph.

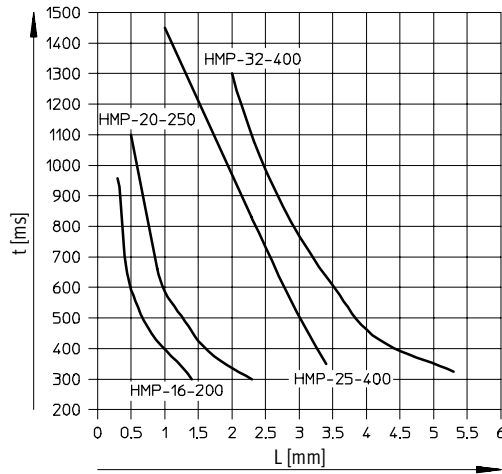
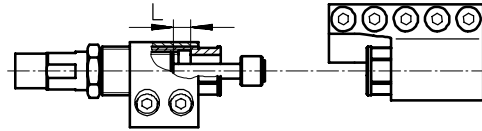

Determination of permissible working load

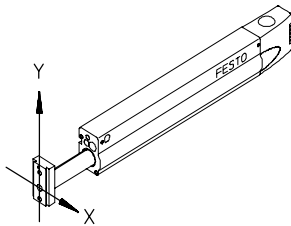

As long as the centre of gravity of the working load on the yoke plate lies within the outline of this plate, it is impossible to overload the linear module.

Centre of gravity

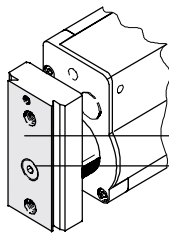

When dovetail mounting components are used, the centre of gravity should be within this area.

Recommended position of centre of gravity for low-vibration operation.

Linear modules HMP

Technical data

Dimensions

Download CAD data → www.festo.com/en/engineering

Piston Ø 16/20 mm

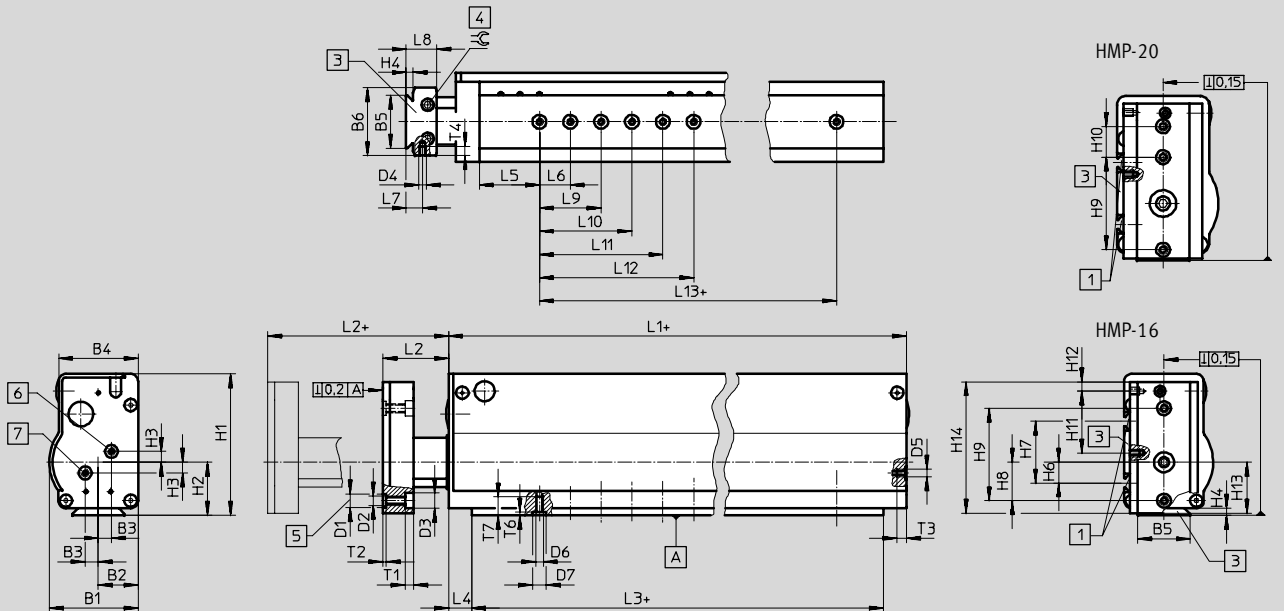

- 1) 2 mounting slots for slot nuts HMBN-5-2M5
- 2) Dovetail mounting facility
- 3) Set screw for clamping of yoke plate (can be turned 360°)
- 4) Thread and centring hole for load attachment with centring sleeves ZBH-9
- 5) Air connection, advancing
- 6) Air connection, retracting
- 7) + = plus stroke length

Type	B1	B2	B3	B4	B5	B6	D1	D2	D3	D4	D5	D6	D7	H1	H2	H3
			±0.1				∅ H7		∅ H13				∅ H7			±0.1
HMP-16	57.8	26	8.5	51.7	34	44	9	M6	10	M5	M5	M5	9	92	34.5	7
HMP-20	65.8	30	10	59.8	34	51	9	M6	10	M5	G1/8	M5	9	107	37	7

Type	H4	H6	H7	H8	H9	H10	H11	H12	H13	H14	L1	L2	L3	L4
					±0.03 ¹⁾	±0.03 ¹⁾								+0.2
HMP-16				25	60	-	40	6	33	85	247	23	217	15
HMP-20	4.5	13.5	40	30	60	20	40	6	45.5	100.4	320	23	290	15

Type	L5	L6	L7	L8	L9	L10	L11	L12	L13	T1	T2	T3	T4	T6	T7	∅
		±0.03		+0.2	±0.03	±0.03	±0.03	±0.03	±0.03		±0.1					
HMP-16	39	20	10.75	20	40	60	80	100	140	5.7	2.1	6.4	6	2.1	12	4
HMP-25	45	20	10.75	20	40	60	80	100	200	5.7	2.1	9	6	2.1	12	4

1) Tolerance specification applies to countersink D1; tolerance for thread D2: ±0.2

Linear modules HMP

Technical data

Dimensions Download CAD data → www.festo.com/en/engineering
 Piston \varnothing 25/32 mm

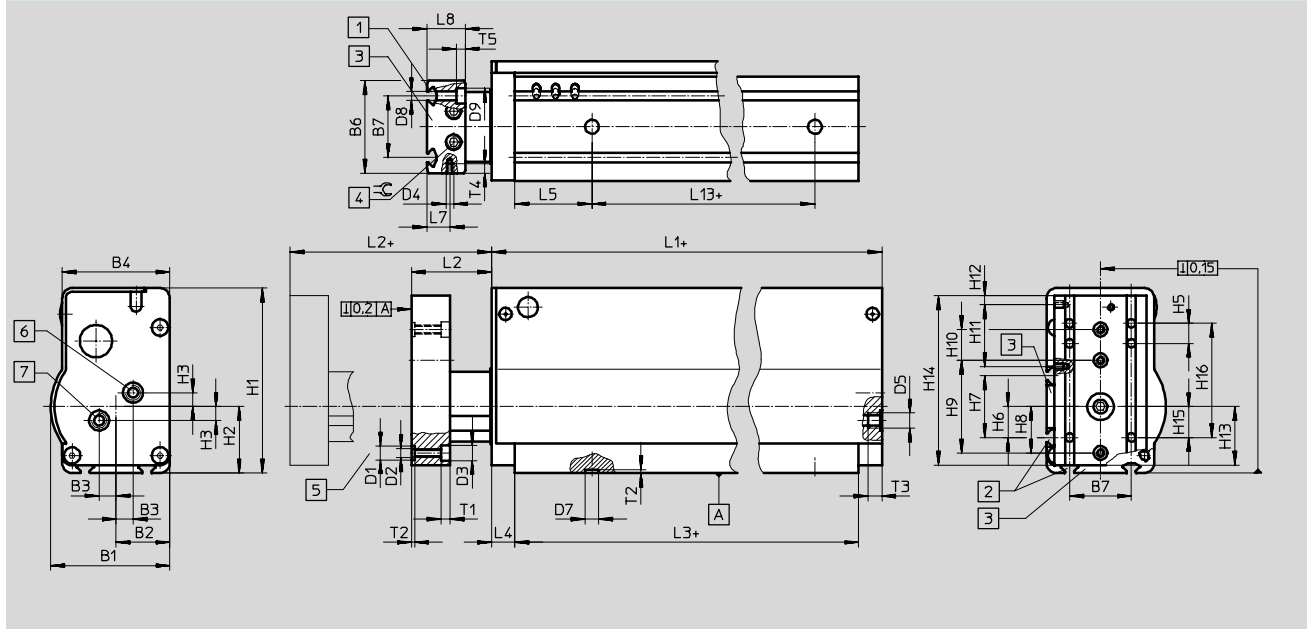

- 1 2 mounting slots for slot nuts HMBN-5-2M5
 - 2 4 mounting slots for slot nuts HMBN-5-2M5
 - 3 Dovetail mounting facility
 - 4 Set screw for clamping of yoke plate (can be turned through 360°)
 - 5 Thread and centring hole for load attachment with centring sleeves ZBH-9
 - 6 Air connection, advancing
 - 7 Air connection, retracting
- + = plus stroke length

Type	B1	B2	B3	B4	B6	B7	D1	D2	D3	D4	D5	D7	D8	D9
			±0.1				\varnothing H7		\varnothing H13			\varnothing H7	\varnothing H13	\varnothing
HMP-25	77.3	35	11	69.8	60	40	9	M6	10	M5	G1/8	9	5.5	10
HMP-32	90.8	40		79.8	70						G1/4			

Type	H1	H2	H3	H5	H6	H7	H8	H9	H10	H11	H12	H13	H14	H15
			±0.1					±0.03 ¹⁾	±0.03 ¹⁾					
HMP-25	120	43	9	13	20	40	30	60	20	40	6	38	110	20
HMP-32	143	53			30		40	80				48	133	

Type	H16	L1	L2	L3	L4	L5	L7	L8	L13	T1	T2	T3	T4	T5	⊕
					+0.2			±0.2	±0.03		±0.1				
HMP-25	74	320	28	290	15	50	15	25	190	5.7	2.1	9	6	5.7	5
HMP-32		427		392					290			12			

1) Tolerance specification applies to countersink D1; tolerance for thread D2: ±0.2

Linear modules HMP

Technical data

Dimensions – Pneumatic connections (code 2G3/2G4/2G6)

Download CAD data → www.festo.com/en/engineering

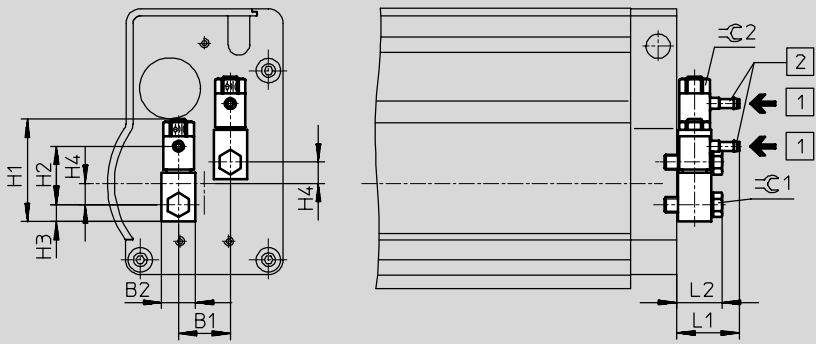

- 1 Exhaust air restrictor
- 2 Tubing connector

Type	B1	B2	H1	H2	H3	H4	L1	L2	∅C1	∅C2
HMP-16-...-2G3	17	11	33.6	19	5.5	7	20.6	15	7	9
HMP-16-...-2G4				22.6						
HMP-20-...-2G4	20	16	48.7	28.9	8	7	31.3	22.2	13	14
HMP-20-...-2G6				27.5						
HMP-25-...-2G4	22	16	48.7	28.9	8	9	31.3	22.2	13	14
HMP-25-...-2G6				27.5						
HMP-32-...-2G4	22	20	61.8	37.9	10	9	35.8	28.2	17	17
HMP-32-...-2G6				38.2						

Dimensions – Clamping unit (code KP)

Download CAD data → www.festo.com/en/engineering

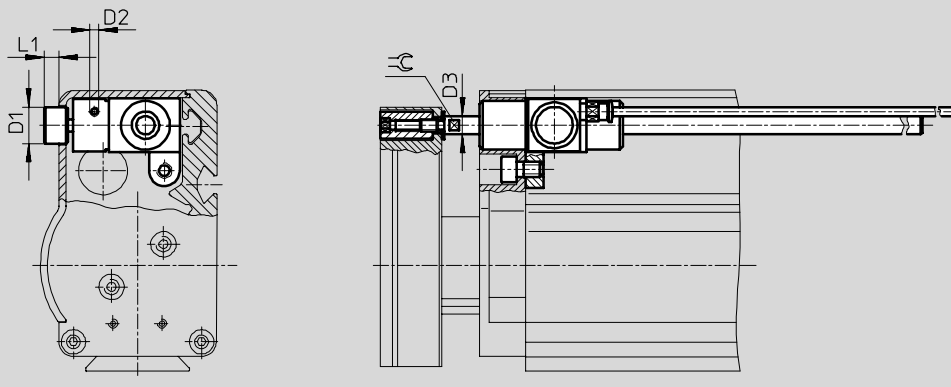

Type	D1 ∅	D2 1)	D3 ∅	L1	∅C	Holding force [N]	Effective load	
							horizontal [kg]	vertical [kg]
HMP-16	11.4	M3	6	5	5	100	10	4
HMP-20				3.8			20	7.5

1) Air connection is supplied ready-fitted with QS connector QSM-M3-4

Note

The clamping unit must only be operated when the shaft is stationary (end position). Dynamic braking operations can result in severe damage to the holding device.

Precision positioning cannot be guaranteed with the clamping unit since slippage of approx. 1-2 mm can occur.

Linear modules HMP

Technical data

Dimensions – End cap
(code AD/EL)

Download CAD data → www.festo.com/en/engineering

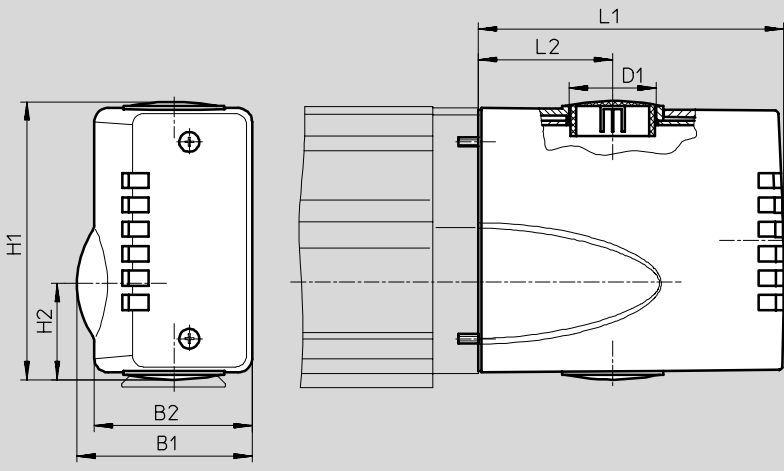

Type	B1	B2	D1 Ø	H1	H2	L1	L2
HMP-16	57.4	51.2	28.5 (PG 21)	91.3	31.5	100	44
HMP-20	65.4	59.2	37.2 (PG 29)	106.3	34.4	120	55
HMP-25	76.9	69.2		119	40.1		
HMP-32	90.4	79.2		141.6	49.9		

Linear modules HMP

Ordering data – Modular products

M Mandatory data →

Module No.	Function	Piston \varnothing	Stroke	Generation	Position sensing	Pneumatic connection
537 940	HMP	16	50	B	SL	2G3
537 941		20	100			2G4
537 942		25	150			2G6
537 943		32	200			
			250			
			320			
			400			
Ordering example	HMP	-	-	- B	- SL	-

Ordering table									
Size	16	20	25	32	Condi- tions	Code	Enter code		
M Module No.	537 940	537 941	537 942	537 943					
Function	Linear module with ball bearing guide						HMP	HMP	
Piston \varnothing [mm]	16	20	25	32		-...			
Stroke [mm]	50	50	-	-		-50			
	100	100	100	100		-100			
	150	150	150	150		-150			
	200	200	200	200		-200			
	250	250	250	250		-250			
	320	320	320	320	320		-320		
	-	400	400	400	400		-400		
Generation	B series						-B	-B	
Position sensing	Sensor strip						-SL	-SL	
Pneumatic connection	One-way flow control valve with barbed fitting for tubing I.D. 3 mm	-	-	-		-2G3			
	One-way flow control valve with barbed fitting for tubing I.D. 4 mm					-2G4			
	-	One-way flow control valve with barbed fitting for tubing I.D. 6 mm				-2G6			

Transfer order code

HMP - - - **B** - **SL** -

Linear modules HMP

Ordering data – Modular products

Options							
Clamping unit	Interface	Proximity sensor set	User manual	Accessories	Plug socket	Slot cover	Centring sleeves
KP	AD EL	A1 A2 A3 A4 A5 A6	E S F I V B	ZUB	...V	A	...Z
-	-	-	-	ZUB	-	-	-

Ordering table								
Size	16	20	25	32	Condi- tions	Code	Enter code	
0 Clamping unit	Clamping cartridge			-	-		-KP	
Interface	End cap						-AD	
	End cap with electrical interface						-EL	
	Proximity sensor set (2 piece), magnetic, supplied separately							
Proximity sensor set (2 piece), magnetic, supplied separately	Proximity sensor with cable, 2.5 m						-A1	
	Proximity sensor, contactless, cable 2.5 m, NPN						-A2	
	Proximity sensor, contactless, cable 2.5 m, PNP						-A3	
	Proximity sensor with plug						1 -A4	
	Proximity sensor, contactless, plug, NPN						1 -A5	
	Proximity sensor, contactless, plug, PNP						1 -A6	
Alternative user documentation (standard is German/English)	User documentation, English						-E	
	User documentation, Spanish						-S	
	User documentation, French						-F	
	User documentation, Italian						-I	
	User documentation, Swedish						-V	
	Express waiver - no manual to be included (already available)						-B	
Accessories	Supplied separately						ZUB-	ZUB-
Plug socket with cable, 2.5 m	1 ... 10						...V	
Slot cover	Slot cover						A	
Centring sleeves (pack of 10)	10, 20, 30, 40, 50, 60, 70, 80, 90						...Z	

1 A4, A5, A6 Not with interface EL

Transfer order code

- - - - **ZUB** -

Linear modules HMP



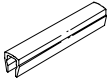
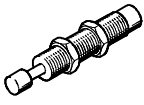





Accessories









Ordering data						
	For piston \varnothing [mm]	Remarks	Order code	Part No.	Type	PU ¹⁾
Centring sleeve ZBH			Technical data → 1 / 10.1-19			
	16 ... 32	For yoke plate	Z	150 927	ZBH-9	10
Slot cover ABP						
	16 ... 32	For sensor strip every 0.5 m	A	151 681	ABP-5	2
Shock absorber YSRW			Technical data → 1 / 9.1-8			
	16	-	-	191 194	YSRW-8-14	1
	20			191 196	YSRW-12-20	
	25			191 196	YSRW-12-20	
	32			191 197	YSRW-16-26	





1) Packaging unit quantity

Linear modules HMP

Accessories

Ordering data – Proximity sensor for slot type 8, magneto-resistive							Technical data → 1 / 10.2-13		
	Mounting	Switch output	Electrical connection			Cable length [m]	Part No.	Type	
			Cable	M8 plug	M12 plug				
NO contact									
	Insertable from above	PNP	3-wire	–	–	2.5	525 898	SMT-8F-PS-24V-K2,5-OE	
		NPN		–	–		525 909	SMT-8F-NS-24V-K2,5-OE	
		–	2-wire	–	–	2.5	525 908	SMT-8F-ZS-24V-K2,5-OE	
		PNP	–	3-pin	–	0.3	525 899	SMT-8F-PS-24V-K0,3-M8D	
		NPN					525 910	SMT-8F-NS-24V-K0,3-M8D	
		PNP					–	–	3-pin
	Insertable from end, flush with the cylinder profile	PNP	3-wire	–	–	2.5	175 436	SMT-8-PS-K-LED-24-B	
		–	–	3-pin	–	0.3	175 484	SMT-8-PS-S-LED-24-B	
NC contact									
	Insertable from above	PNP	3-wire	–	–	7.5	525 911	SMT-8F-PO-24V-K7,5-OE	

Ordering data – Proximity sensor for slot type 8, magnetic reed							Technical data → 1 / 10.2-16		
	Mounting	Electrical connection			Cable length [m]	Part No.	Type		
		Cable	M8 plug						
NO contact									
	Insertable from above	3-wire		–	2.5	525 895	SME-8F-DS-24V-K2,5-OE		
		2-wire		–	5.0	525 897	SME-8F-DS-24V-K5,0-OE		
		–		3-pin	–	2.5	525 907	SME-8F-ZS-24V-K2,5-OE	
		–		–	–	0.3	525 896	SME-8F-DS-24V-K0,3-M8D	
	Insertable from end, flush with the cylinder profile	3-wire		–	2.5	150 855	SME-8-K-LED-24		
		–		3-pin	–	0.3	150 857	SME-8-S-LED-24	
		–		–	–	–	–	–	
NC contact									
	Insertable from above	3-wire		–	7.5	525 906	SME-8F-DO-24V-K7,5-OE		

Ordering data – Plug sockets							Technical data → 1 / 10.2-100		
	Mounting	Switch output		Connection	Cable length [m]	Part No.	Type		
		PNP	NPN						
Straight plug socket									
	Union nut M8	■	■	3-pin	2.5	159 420	SIM-M8-3GD-2,5-PU		
		■	■		5	159 421	SIM-M8-3GD-5-PU		
	Union nut M12	■	■	3-pin	2.5	159 428	SIM-M12-3GD-2,5-PU		
		■	■		5	159 429	SIM-M12-3GD-5-PU		
Angled plug socket									
	Union nut M8	■	■	3-pin	2.5	159 422	SIM-M8-3WD-2,5-PU		
		■	■		5	159 423	SIM-M8-3WD-5-PU		
	Union nut M12	■	■	3-pin	2.5	159 430	SIM-M12-3WD-2,5-PU		
		■	■		5	159 431	SIM-M12-3WD-5-PU		

 Core Range

